



Standard Test Methods for Rubber Property—Adhesion to Flexible Substrate¹

This standard is issued under the fixed designation D 413; the number immediately following the designation indicates the year of original adoption or, in the case of revision, the year of last revision. A number in parentheses indicates the year of last reapproval. A superscript epsilon (ϵ) indicates an editorial change since the last revision or reapproval.

This standard has been approved for use by agencies of the Department of Defense.

1. Scope

1.1 These test methods cover the determination of the adhesion strength between plies of fabric bonded with rubber or the adhesion of the rubber layer in articles made from rubber attached to other material. They are applicable only when the adhered surfaces are approximately plane or uniformly circular as in belting, hose, tire carcasses, or rubber-covered sheet metal.

1.2 When the adhered surfaces contain sharp bends, angles, or other gross irregularities that cannot be avoided in preparing test specimens, special test methods must be employed for evaluating adhesion.

1.3 The values stated in SI units are to be regarded as the standard. The values given in parentheses are for information only.

1.4 *This standard does not purport to address all of the safety problems, if any, associated with its use. It is the responsibility of the user of this standard to establish appropriate safety and health practices and determine the applicability of regulatory limitations prior to use.*

2. Referenced Documents

2.1 ASTM Standards:

D 3040 Practice for Preparing Precision Statements for Standards Related to Rubber and Rubber Testing²

D 3182 Practice for Rubber—Materials, Equipment, and Procedures for Mixing Standard Compounds and Preparing Standard Vulcanized Sheets³

D 3183 Practice for Rubber—Preparation of Pieces for Test Purposes from Products³

NOTE 1—The specific dated edition of Practice D 3040 that prevails in this document is referenced in the Precision section.

3. Summary of Test Method

3.1 Two general test methods are given:

¹ These test methods are under the jurisdiction of ASTM Committee D-11 on Rubber and are the direct responsibility of Subcommittee D11.25 on Rubber Adhesive Systems.

Current edition approved Nov. 10, 1998. Published December 1998. Originally published as D 413 – 35 T. Last previous edition D 413 – 82 (Reapproved 1993) ^{ϵ 1}.

² Discontinued—see 1986 Annual Book of ASTM Standards, Vols. 09.01 and 09.02.

³ Annual Book of ASTM Standards, Vol 09.01.

3.1.1 *Static-Mass Method*, in which the force required to cause separation between adhered surfaces is applied by means of gravity acting on a mass.

3.1.2 *Machine Method*, in which the force required to cause separation between adhered surfaces is applied by means of a tension machine.

3.2 Except as may be otherwise specified in these test methods, the requirements of Practices D 3182 and D 3183, shall be complied with and are made a part of these test methods.

3.3 In case of conflict between the provisions of these test methods and those of detailed specifications or test methods for a particular material, the latter shall take precedence.

3.4 As covered by these test methods, an adhesion test consists of applying to a test specimen, under specified conditions, a (measured) force sufficient to strip from the specimen at a measured rate, a layer of moderate thickness with separation (rupture, tearing) at the adhered surfaces. The numerical value of the adhesion is expressed as (1) the average force required to cause separation at a definite rate, or (2) the average rate of separation caused by a known or specified force. In the machine test method, the rate of separation is fixed and the adhesion value must be expressed in terms of the measured force. With the static-mass test method, either (1) or (2) can be used, but the latter is preferable and will be here employed.

4. Significance and Use

4.1 These test methods are used to ensure the quality of a product by determining the force per unit width required to separate a rubber layer from a flexible substrate such as fabric, fibre, wire, or sheet metal. The acceptable value of adhesion measured will, of course, vary from product to product due to different rubber formulations, flexible substrates, and types of products. However, once a product is established, minimum values of separation force can be determined and agreed to by producer and consumer and both can monitor to assure maintenance of the agreed-upon minimum value.

STATIC-MASS METHOD

5. Apparatus

5.1 The apparatus required for the adhesion test by the static-mass test method consists of a supporting frame, testing

clamps, mandrels, calibrated masses, and mass carriers. The supporting frame is of such design that clamps for strip specimens hang on it vertically and that mandrels for ring specimens are supported on it horizontally. The frame has sufficient height to permit the mass carrier to be suspended from the test specimens by means of clamps and to hang freely during the progress of the test. Provision also is made to support the mandrels so that they revolve freely with minimum friction. Suitable apparatus is shown in Fig. 1 and Fig. 2.

6. Test Specimens

6.1 *Strip Specimens—Type A*—Plane strips having a width of $25 + 3, - 0$ mm ($1 + 0.125, - 0$ in.), and a minimum length such as to permit 180° peel separation over sufficient distance to indicate the adhesion value.

6.1.1 Cut the specimen to $25 + 3, - 0$ mm ($1 + 0.125 - 0$ in.) wide. The thickness will vary according to the construction of the article being tested. The maximum thickness of the specimen is limited to 13 mm (0.5 in.). To comply with this requirement, slice or buff the specimen. The ply or layer being separated should never be over 6.5 mm (0.25 in.) thick.

6.1.2 Cut the specimen from the article in such a manner that the adhered parts have the same width where practicable.

The technique used in 6.2.2 and 6.2.3 may be applied here. When necessary, or specified, cut only the layer to be separated (by application of load) to the prescribed width. In such cases, remove the portions of that layer remaining outside of the test width to avoid edge constriction during separation.

6.1.3 Curved specimens for test in strip form shall have curvature only in the length dimension of the specimen.

6.2 *Strip Specimens—Type B*—The same as Type A, with the exception of 90° peel and the separation line in the center of the specimen.

6.2.1 Cut the specimen 35 mm ($1\frac{3}{8}$ in.) wide. Remove the excess plies to obtain a thickness of 6 mm ($\frac{1}{4}$ in.) and leave the separation line in the center of the specimen to ensure a 90° peel.

6.2.2 Buff to a width of 30 mm ($1\frac{1}{8}$ in.) with a coarse grit emery cloth (grit No. 40) with care to prevent burning or gumming the sides of the specimen.

6.2.3 Make a 2-mm ($\frac{1}{16}$ -in.) deep slit with a knife along each side exactly where the specimen is to be separated during testing. Use a knife with an adjustable blade where only the desired depth of cut (2 mm) of blade is exposed.

6.3 *Ring Specimens*—Closed rings having a width of 25 mm (1 in.) and maximum internal diameter of 100 mm (4 in.).

6.3.1 Mount the article on a smooth, close-fitting, slightly tapered wooden mandrel.

6.3.2 Rotate the mandrel (a lathe is preferred) and cut 25-mm (1-in.) wide ring sections by forcing a sharp pointed knife gradually through the article.

6.3.3 Cut rings with internal diameters over 100 mm (4 in.) through and open to form strip specimens.

7. Procedure

7.1 *Strip Specimen: Type A, 180° Peel*—Measure the width of the strip cut to the nearest 0.2 mm (0.01 in.) and record. Separate the parts to be tested by hand at one end of the strip specimen and at a sufficient distance to permit the jaws of the testing clamp to be attached. Suspend the strip from the supporting frame by the separated end, holding in the jaws of the testing clamp all separated ends except the one under test. Attach to the lower end of the test specimen a minimum mass sufficient to maintain the strip specimen in approximately a vertical position. Or, hold the specimen against a vertical plate in such a manner as to keep the specimen in approximately a vertical position during the test to ensure a 180° peel. Apply a specified or known mass by means of a clamp and mass carrier to the layer of which the adhesion is being determined. Include the mass of the clamp and carrier in the total mass causing separation. Release the mass slowly without jerking and in such a manner that the separating layer is stripped from the specimen at an angle of approximately 180° .

7.2 *Strip Specimen: Type B, 90° Peel*—Test specimens in the same manner as Type A, with the exception that the unpeeled portion of the specimen is kept in a horizontal position using a plate, if necessary, to ensure a 90° peel.

7.3 *Ring Specimens*—Place the ring specimen snugly on a mandrel that has an outside diameter substantially the same as the internal diameter of the ring. Separate the parts to be tested sufficiently by hand to permit the jaws of the testing clamp to be attached. With the mandrel resting on the supporting frame,

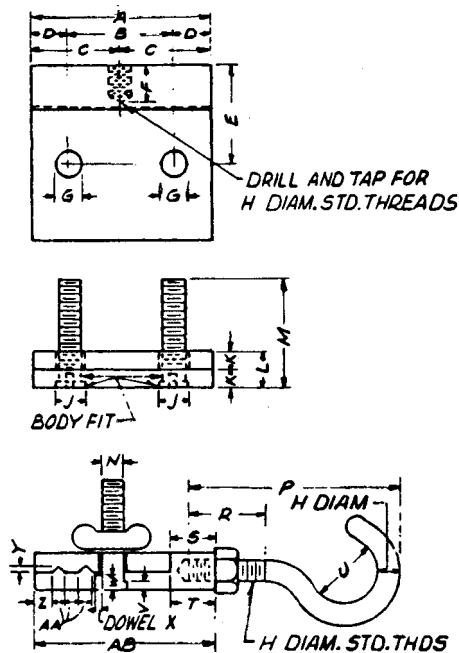

Dimension	mm	in.	Dimension	mm	in.
A	75.0	3	N	10.0	$\frac{1}{8}$
B	45.0	$1\frac{1}{4}$	P	90.0	$3\frac{1}{2}$
C	37.5	$1\frac{1}{2}$	R	30.0	$1\frac{1}{4}$
D	15.0	$\frac{3}{8}$	S	20.0	$\frac{3}{4}$
E	40.0	$1\frac{1}{16}$	T	18.0	$2\frac{3}{32}$
F	15.0	$\frac{1}{8}$	U	30.0	$1\frac{1}{8}$
G	10.0	$\frac{11}{16}$	V	3.0	$\frac{1}{8}$
H	11.0	$1\frac{3}{32}$	W	6.0	$\frac{1}{4}$
J	13.0	$\frac{1}{2}$	X	3.0	$\frac{1}{8}$
K	8.0	$\frac{1}{16}$	Y	3.0	$\frac{7}{64}$
L	16.0	$\frac{3}{8}$	Z	8.0	$\frac{5}{16}$
M	50.0	$1\frac{1}{8}$	AA	6.0	$\frac{7}{32}$
			AB	75.0	3

FIG. 1 Clamp for Adhesion Test

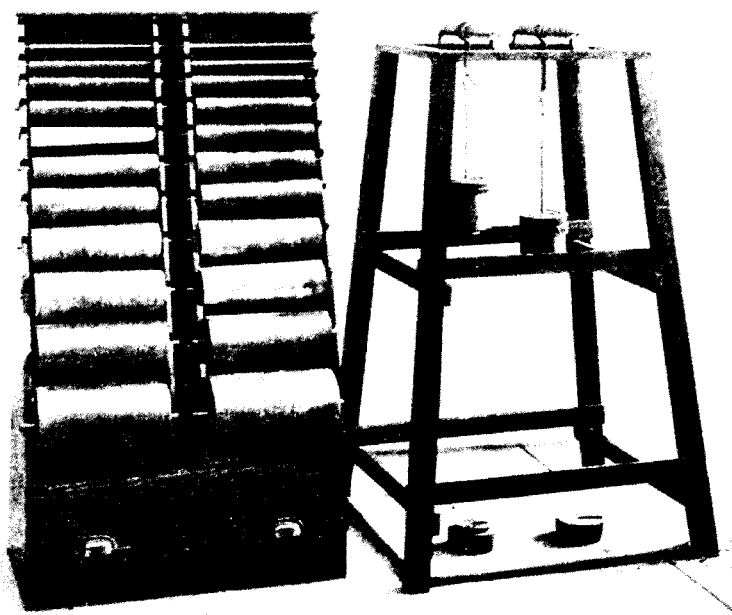

FIG. 2 Mandrels and Frame for Static Mass Adhesion Test

apply a known or specified mass by means of the clamp and a mass carrier to the layer of which the adhesion is being tested. Include the mass of the clamp and carrier in the total mass causing separation. Release the mass slowly without jerking and in such a manner that the separating layer is stripped from the specimen at an angle of approximately 90°.

7.4 *Rate of Separation*—Record the time needed to complete the separation using a stop watch or a watch having a second hand. Remove the mass and measure the length stripped between marks placed at the beginning and end of the test on the portion other than that stripped.

MACHINE METHOD

8. Apparatus

8.1 A tension testing machine, power-driven, accurate to within $\pm 1\%$ is used for measuring the force required to separate the layers of the test specimen. A constant rate of extension testing machine satisfies this condition and is preferred although an inclination-balance, pendulum-type, or a spring-balance apparatus may be used. Requirements of the testing machine are in 8.2.1 to 8.2.58.2.6.

8.2 Testing Machine:

8.2.1 The testing machine shall be capable of being operated without any device for maintaining maximum load indication. For pendulum-type machines, do not engage pawls that prevent the mass lever from swinging freely.

8.2.2 The machine shall be equipped with the chart where the distance separated is one axis and the applied force is the other axis of coordinates. The preferred chart speed is the same as the cross-head speed for ring specimens and one half the cross-head speed for strip specimens.

8.2.3 The force applied shall be greater than 15 % and less than 85 % of the capacity of the machine.

8.2.4 *Grips*—Strip specimens shall be held in the testing machine by grips that clamp firmly and prevent slipping at all times during the test. For ring specimens, replace the grip attached to the recording head of the machine with a freely rotating mandrel with an outside diameter substantially the same as the inside diameter of the ring specimen. Mount the mandrel so that its axis of rotation is in the plane of the ply being separated and the applied force is normal to the tangent of the ring circumference at the line of separation.

8.2.5 The preferred rate of travel of the power-actuated grip is 0.8 mm/s (2 in./min) for strip specimen Type A, 2.5 mm/s (6 in./min) for Type B, and 0.4 mm/s (1 in./min) for ring specimens. These rates are to be uniform throughout the tests.

9. Test Specimens

9.1 Prepare the specimens in accordance with Section 6.

10. Procedure

10.1 *Strip Specimens: Type A, 180° Peel*—Measure the width of the cut strip to the nearest 0.2 mm (0.01 in.) and record. Separate the parts to be tested by hand at one end of the test specimen and at a sufficient distance to permit grips of the machine to be attached. Attach the separated end of the specimen, with all separate parts except the one under test securely gripped, to the recording head by means of a clamp, using care to adjust it symmetrically in order that the tension shall be distributed uniformly. Provide for maintaining the strip during the test approximately in the plane of the clamps. This may be done either by attaching the minimum mass required to the free end of the specimen or by holding the specimen against

a plate attached to the stationary clamp but, in either case, take into account the added mass in determining the force causing separation. Grip that layer of the specimen of which the adhesion is to be tested symmetrically and firmly without twisting in the power-actuated clamp. Adjust the autographic mechanism and chart to zero and start the machine. Strip the separating layer from the specimen at an angle of approximately 180°, and continue the separation for a sufficient distance to indicate the adhesion value.

10.2 *Strip Specimen: Type B, 90° Peel*—Separate by hand a sufficient distance along the separation line in the center of the strip to permit the grips of the machine to be attached. Make provision to keep the unpeeled portion of the test specimen in a horizontal position using a plate if necessary to ensure a 90° peel. Peel along the previously cut separation layer for 40 to 100 mm (1½ to 4 in.).

10.3 *Ring Specimens*—Separate by hand a sufficient length of a layer of the specimen to be tested to permit the power-actuated clamp of the machine to be attached. Place the specimen snugly on the test mandrel. With the mandrel attached to the recording head of the machine and the separated layer gripped symmetrically and firmly without twisting in the power-actuated clamp, adjust the autographic mechanism and chart to zero and start the machine. Strip the separating layer from the specimen at an angle of approximately 90° to the tangent of the specimen surface, and continue the separation for a sufficient distance to indicate the adhesion value. During the test, the mandrel shall rotate freely so as to maintain the line of separation at all times approximately in the same position.

PRECAUTIONS, INTERPRETATION, CALCULATION, AND REPORT

11. Precautions

11.1 Tearing:

11.1.1 If, during a test, the substrate rubber begins to tear instead of separating at the bonded interface, cut the material being torn with a knife up to the surface of contact between the two parts and start the test again.

11.1.2 If one of the substrate rubbers repeatedly tears, instead of separating from the other part at the bonded interface, a satisfactory result may be secured in the static-mass method by reducing the amount of the mass used if this is permitted. In case of repeated tearing when using the machine test method, take as the result of the test the average load at which tearing of the substrate rubber occurs.

11.2 *Effect of Temperature*—The results of this test are affected by temperature. Elevating the temperature causes a faster rate of stripping under a given load. The temperature during test shall therefore be 23 ± 2°C (73.1 ± 3.6°F) and the actual temperature shall be recorded.

12. Interpretation of Results

12.1 In the static-mass test method, no stripping is started unless a certain mass is used. Small increments in mass do not progressively cause proportional increases in rate of separation. With increasing mass the rate increases slowly at first and finally very rapidly. Rate of separation must therefore be

interpreted carefully. A specimen required to separate not more than 0.4 mm/s (1 in./min) under a force of 90 N (20 lbf) might be regarded as very inferior if the test result was 2 mm/s (5 in./min). The same specimen might not strip at all under a force of 67 N (15 lbf) and might meet the requirement with a force of 80 N (18 lbf).

12.2 The true adhesion value is not determined in case the specimens repeatedly tear. The test, however, indicates that the strength of adhesion exceeds the strength of the material and that the adhesion value is not less than the result obtained. In cases of tearing, the results should be so designated.

12.3 Adhesion values may differ between different plies of the same article of plied construction and also at different points along the same ply. The adhesion value of one ply to another is taken as the average result of the test over a reasonable distance of separation. When possible, a distance of separation of at least 100 mm (4 in.) shall be used.

13. Calculation

13.1 For the Static-Mass Test Method, report the adhesion value as separation rate per unit width under a stated force, as follows:

$$\begin{array}{l} \text{mm/s for 25-mm width under N force} \\ \text{in./s for 1-in. width under lbf} \end{array} \quad (1)$$

If a width other than 25 mm (1 in.) was used, correct the separation by multiplying the rate by the ratio of actual width to the desired width. Include both the rate and the actual width in the report.

13.2 For the machine test method, the autographic chart constitutes the report, but the value of the adhesion is determined by drawing on the chart the best average line between the maximum and minimum force values. The force so indicated, expressed in newtons per metre (or pounds-force per inch) is divided by the width measured in 10.1 for separation at the rate used and is reported as the adhesion strength, as follows:

$$\text{Adhesion Strength} = \text{N/m (lbf/in.)} = \text{force/actual width} \quad (2)$$

Show both the force and actual width in the report.

14. Report

14.1 The report shall include the following:

14.1.1 Results of the adhesion test expressed in accordance with Sections 12 and 13,

14.1.2 All observations and recorded data on which the results are based,

14.1.3 Date of manufacture or vulcanization of rubber, if known,

14.1.4 Date of test,

14.1.5 Statement of the method used, (Strip Type A, Strip Type B, or Ring; Static-Mass or Machine),

14.1.6 Temperature of test room, and

14.1.7 Dimensions of the test specimen.

15. Precision and Bias

15.1 Precision and bias do not exist for this method because resources necessary for round-robin testing have not been forthcoming.



16. Keywords

16.1 adhesion; fabric; rubber

The American Society for Testing and Materials takes no position respecting the validity of any patent rights asserted in connection with any item mentioned in this standard. Users of this standard are expressly advised that determination of the validity of any such patent rights, and the risk of infringement of such rights, are entirely their own responsibility.

This standard is subject to revision at any time by the responsible technical committee and must be reviewed every five years and if not revised, either reapproved or withdrawn. Your comments are invited either for revision of this standard or for additional standards and should be addressed to ASTM Headquarters. Your comments will receive careful consideration at a meeting of the responsible technical committee, which you may attend. If you feel that your comments have not received a fair hearing you should make your views known to the ASTM Committee on Standards, 100 Barr Harbor Drive, West Conshohocken, PA 19428.