



Designation: D 429 – 02a

## Standard Test Methods for Rubber Property—Adhesion to Rigid Substrates<sup>1</sup>

This standard is issued under the fixed designation D 429; the number immediately following the designation indicates the year of original adoption or, in the case of revision, the year of last revision. A number in parentheses indicates the year of last reapproval. A superscript epsilon ( $\epsilon$ ) indicates an editorial change since the last revision or reapproval.

*This standard has been approved for use by agencies of the Department of Defense.*

### 1. Scope

1.1 These test methods cover procedures for testing the static adhesional strength of rubber to rigid materials (in most cases metals).

*Method A*—Rubber Part Assembled Between Two Parallel Metal Plates.

*Method B*—90° Stripping Test—Rubber Part Assembled to One Metal Plate.

*Method C*—Measuring Adhesion of Rubber to Metal with a Conical Specimen.

*Method D*—Adhesion Test—Post-Vulcanization (PV) Bonding of Rubber to Metal.

*Method E*—90° Stripping Test—Rubber Tank Lining—Assembled to One Metal Plate.

*Method F*—Rubber Part Assembled Between Two Parallel Convex-Shaped Metal Plates

*Method G*—Measuring Bond Durability for Rubber-to-Metal Bonded Components with a Double Shear Cylindrical Specimen

1.2 While the test method may be used with a wide variety of rigid materials, use of materials other than metals is the exception. For this reason, we have used the word “metal” in the text rather than “rigid materials.”

1.3 The values stated in SI units are to be regarded as the standard. The values given in parentheses are for information only.

1.4 *This standard does not purport to address all of the safety concerns, if any, associated with its use. It is the responsibility of the user of this standard to establish appropriate safety and health practices and determine the applicability of regulatory limitations prior to use.*

### 2. Referenced Documents

#### 2.1 ASTM Standards:

B 117 Practice for Operating Salt Spray (Fog) Apparatus<sup>2</sup>

<sup>1</sup> These test methods are under the jurisdiction of ASTM Committee D11 on Rubber and are the direct responsibility of Subcommittee D11.25 on Rubber Adhesive Systems.

Current edition approved Dec. 10, 2002. Published February 2003. Originally approved in 1935. Last previous edition approved in 2002 as D 429 – 02.

<sup>2</sup> *Annual Book of ASTM Standards*, Vol 03.02.

D 395 Test Methods for Rubber Property—Compression Set<sup>3</sup>

D 412 Test Methods for Vulcanized Rubber and Thermoplastic Elastomers—Tension<sup>3</sup>

D 413 Test Methods for Rubber Property—Adhesion to Flexible Substrate<sup>3</sup>

D 471 Test Method for Rubber Property—Effect of Liquids<sup>3</sup>

D 572 Test Method for Rubber—Deterioration by Heat and Oxygen<sup>3</sup>

D 573 Test Method for Rubber—Deterioration in an Air Oven<sup>3</sup>

D 1149 Test Method for Rubber Deterioration—Surface Ozone Cracking in a Chamber<sup>3</sup>

D 3182 Practice for Rubber—Materials, Equipment, and Procedures for Mixing Standard Compounds and Preparing Standard Vulcanized Sheets<sup>3</sup>

D 3183 Practice for Rubber—Preparation of Pieces for Test Purposes from Products<sup>3</sup>

D 3491 Methods of Testing Vulcanizable Rubber Tank and Pipe Linings<sup>4</sup>

E 4 Practices for Force Verification of Testing Machines<sup>5</sup>

G 23 Practice for Operating Light-Exposure Apparatus (Carbon-Arc Type) With and Without Water for Exposure of Nonmetallic Materials<sup>6</sup>

### 3. Significance and Use

3.1 These test methods are designed primarily for specimens prepared in a laboratory under standardized conditions such as may be used to provide data for development and control of rubber compounds and methods of manufacture. With slight modifications as indicated, Methods A, B, C, D, and E are also used for obtaining comparative adhesional test values of production parts whenever the design permits preparation of suitable test specimens. Methods A, B, C, and D are

<sup>3</sup> *Annual Book of ASTM Standards*, Vol 09.01.

<sup>4</sup> Discontinued—see 1997 *Annual Book of ASTM Standards*, Vol 09.02.

<sup>5</sup> *Annual Book of ASTM Standards*, Vol 03.01.

<sup>6</sup> *Annual Book of ASTM Standards*, Vol 14.04. This practice is also in the 1978 SAE Handbook.

applicable in the case of many products in which rubber is used for controlling vibration.

**METHOD A—RUBBER PART ASSEMBLED  
BETWEEN  
TWO PARALLEL METAL PLATES**

**4. Terminology Adhesion Failure Terminology**

4.1 *R* indicates the failure is in the rubber.

4.2 *RC* indicates the failure is at the rubber-cover cement interface.

4.3 *CP* indicates the failure is at the cover cement-prime cement interface.

4.4 *M* indicates the failure is at the metal-prime cement interface.

NOTE 1—*Example*—The percentages of the various types of failure may be estimated as in the following examples:

*R-50, RC-50* means that roughly one half or 50 % of the area showed failure in the rubber and the other 50 % showed failure at the rubber cover cement interface.

*R-25, RC-25, M-50* means three types of failure were present with the *M* indicating 50 % failure at the metal-primer interface.

**5. Significance and Use**

5.1 Method A is used to determine adhesion values in instances where users feel this design is more reflective of an actual product and where control tests have been set up as a result. The sample also lends itself to testing the effectiveness of different processing techniques and various adhesive systems.

**6. Apparatus**

6.1 *Testing Machine*—A tension testing machine conforming to the requirements of Practices E 4 shall be used for measuring the strength of adhesion. The moving head of the machine shall travel at the rate of  $0.40 \pm 0.04$  mm/s ( $1.0 \pm 0.1$

in./min). The machine shall be provided with a recording device to give the total force at the conclusion of the test. A machine of not more than 40 kN (10 000 lbf) capacity will be found suitable in most cases.

6.2 *Grips*—The fixtures for holding the specimen in the testing machine will depend on the type of specimen but in all cases shall be provided with ball seats to permit proper centering of the load during the test. A typical adhesion test assembly is shown in Fig. 1. Specially molded laboratory specimens shall be attached by means of threaded studs on the metal parts as shown in Fig. 2, but with specimens cut from production parts the clamp illustrated in Fig. 3 may be used.

**7. Standard Test Specimens**

7.1 The standard test specimen shall consist of a cylinder of rubber  $3.2 \pm 0.1$  mm thick ( $0.125 \pm 0.005$  in.) and an end area of  $1250 \pm 5$  mm<sup>2</sup> or  $2.00 \pm 0.01$  in.<sup>2</sup> (diameter of  $39.9 \pm 0.1$  mm ( $1.597 \pm 0.005$  in.)) attached to the faces of two metal plates each at least 9.5 mm (0.37 in.) in thickness and of the same diameter as the rubber cylinder. The metal plates shall have smooth flat faces that shall be parallel in the finished specimen. The cylindrical shape is used to eliminate sharp corners and to give uniform distribution of the pulling force.

NOTE 2—While a 1250 mm<sup>2</sup> (2 in.<sup>2</sup>) area test specimen shall be considered the standard for reference purposes, it shall be permissible to use a specimen of only 625 mm<sup>2</sup> (1 in.<sup>2</sup>) in area, when it is desirable to prepare and cure a large number of test specimens at one time. The diameter of this test specimen shall be  $28.21 \pm 0.02$  mm ( $1.129 \pm 0.001$  in.) and the unvulcanized piece shall be cut to dimensions of approximately 24 mm ( $1\frac{5}{16}$  in.) in diameter and approximately 5 mm ( $\frac{3}{16}$  in.) in thickness (approximately 10 % volume excess).

**8. Laboratory Preparation of Standard Test Specimens**

8.1 Prepare the standard test specimen to be used for development and control purposes in the laboratory as described in 8.2 through 8.6.

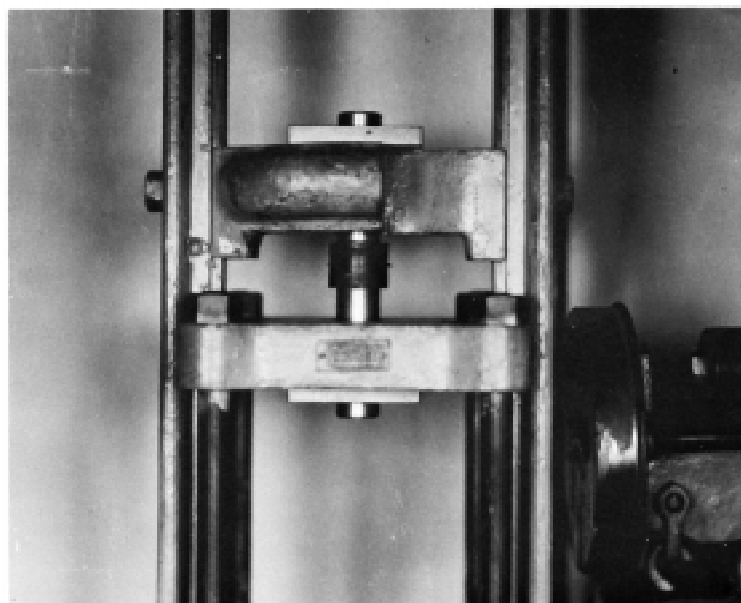

**FIG. 1 An Example of an Adhesion Test Specimen Attached in a Testing Machine**

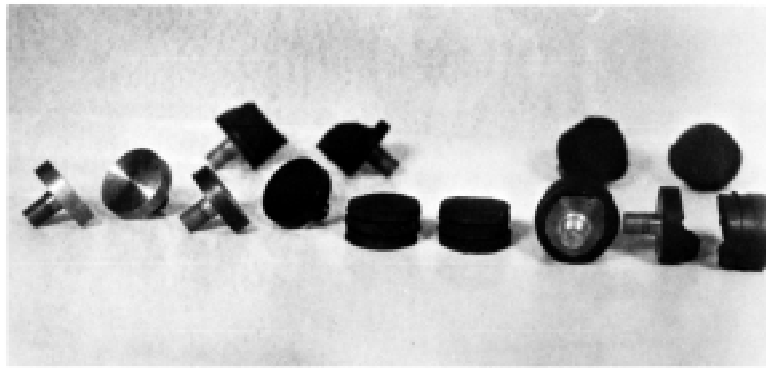

**FIG. 2 Views of a Typical Test Specimen Showing Individual Metal Parts and Rubber Cylinders**

8.2 Machine circular metal parts of standard dimensions from rolled bar steel SAE No. 1020<sup>7</sup> for standard reference pieces. However, other metals may be used if in conformity with the essential dimensions. Prepare smoothly machined test faces of the metals in accordance with any test method for securing adhesion that may be under investigation.

8.3 Cut unvulcanized rubber pieces to dimensions of approximately 35 mm (1 3/8 in.) in diameter and approximately 5 mm (3/16 in.) in thickness so as to give maximum pressure of the rubber against the metal surface during vulcanization (see Fig. 2). Clean or treat surfaces to be adhered in accordance with the method being investigated.

8.4 Assemble the metal parts and rubber pieces for vulcanization in the mold. A typical mold and test piece are shown in Fig. 4. The test method of assembly is illustrated in Fig. 2. The mold is so constructed that there is obtained after vulcanization approximately 0.039 mm (0.0015 in.) of rubber over the edge of the metal to eliminate tearing of the rubber during test from the sharp edge of the metal. Prior to vulcanization, take great care to keep the surfaces to be adhered clean and free of dust, moisture, or other foreign material. Do not touch surfaces with the hands.

8.5 Vulcanize by heating the mold for a definite time at a controlled temperature in a hydraulic vulcanization press. Choose the time and temperature of cure according to the rubber compound used. At the conclusion of the cure, take care in removing the specimens from the mold to avoid subjecting the adhered surfaces to stress before the specimens have cooled.

8.6 After vulcanization, store the specimens at a temperature of 23 ± 2°C (73.4 ± 3.6°F) at least 16 h prior to testing.

## 9. Test Specimens from Production Parts

9.1 For comparative test of adhesion in production parts, it is necessary to select a portion of the part so that a specimen consisting of a rubber piece sandwiched between two parallel plates of metal may be cut. Hollow-mill a specimen out of the production part and finish the piece either by turning or grinding down to size in such a manner that the surfaces of the rubber and metal shall be free of imperfections that would have

any tendency to start a tear in the rubber part during the application of tension while testing.

9.2 In routine production testing, it is sometimes necessary to test specimens of different size and shape than those specified as standard. In such cases, the test method of preparation shall be similar to that given in 9.1, but the test results secured shall not be compared with those obtained using the standard test specimen.

## 10. Procedure

10.1 Mount the vulcanized standard test specimen or the specimen cut from a production part in the testing machine, as shown in Fig. 1, using care in centering and adjustment so that the tension shall be uniformly distributed. Apply a steady tension load at the specified machine speed until the rubber either separates from the metal surface or ruptures. Record the total force at the time of failure.

10.2 In case of rupture in the rubber, the strength of the adhesion bond is obviously not measured, but is shown to be greater than the strength of the rubber itself. Record the type or types of failure, and express in accordance with the adhesion failure terminology described in Section 5. Estimate and record the percentages of the various types of failures.

## 11. Calculation

11.1 Express the adhesion value in pascals or pounds-force per square inch and calculate by dividing the tension force causing failure by the original area of the adhered surface that separates. In case of rupture of the rubber, the adhesion value is recognized as being higher than that reported.

## 12. Report

12.1 The report shall include the following, preferably reported on an Adhesion Test Data Sheet as illustrated in Table 1:

12.1.1 The result, calculated in accordance with Section 11,

12.1.2 All observed and recorded data including the number of test pieces involved,

12.1.3 Notation of type or types of failure, and the estimated percentages of the various types of failures (Section 10),

12.1.4 A description of the specimen including a statement of the test method used for determining adhesion, if known, and a notation indicating whether the specimen was molded in the laboratory or prepared from a production part,

<sup>7</sup> Supporting data are available from ASTM Headquarters. Request RR: D11-1040.

**METHOD B—90° STRIPPING TEST—RUBBER PART ASSEMBLED TO ONE METAL PLATE**

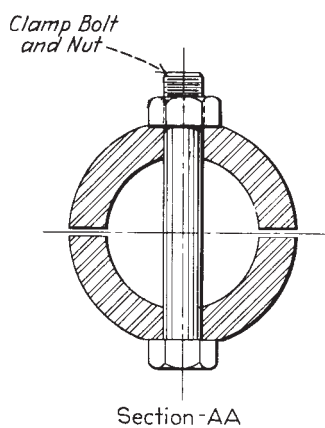
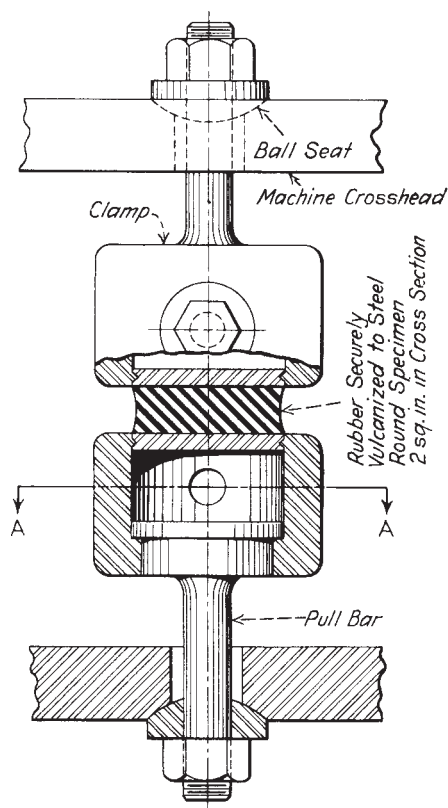

Section-AA

2 in.<sup>2</sup> = 12.9 cm<sup>2</sup>

**FIG. 3 Method of Testing Adhesion When Sample Section is Taken from Production Parts**

- 12.1.5 Dimensions of the test specimen (comparisons may be made only among specimens of the same size and shape),
- 12.1.6 Date of manufacture or vulcanization, if known,
- 12.1.7 Time and temperature of vulcanization, if known,
- 12.1.8 Temperature of test room, and
- 12.1.9 Date of test.

**13. Precision and Bias <sup>7</sup>**

13.1 Precision and bias do not exist for this test method because resources necessary for round-robin testing have not been forthcoming.

**14. Significance and Use**

14.1 This test is intended for determining the adhesive strength of rubber-to-metal bonding agents. The results are obtained by measuring the force necessary to separate a rubber from a metal surface. The data obtained indicate the strength of adhesion along a line across the width of the rubber strip being separated from a metal plate at a 90° angle. The test provides valuable data for development and control of rubber compounds and test methods of bonding, and it also serves as a screening test for the evaluation of various bonding agents or techniques, or both.

NOTE 3—It is permissible to use a 45° angle to bring about separation, but if this is done, the same should be indicated on the form on which the data are recorded. If this notation does not appear, it must be assumed that the 90° angle has been used. The angle of pull, in this case 45°, merely means that the equipment has been so designed that the angle made by that face of the rubber being stripped from the metal and the metal to which it has been adhered is 45°. Experience indicates a lower force is obtained for the 45° angle than for the 90° angle, and also a break significantly closer to the bond interface.

**15. Adhesion Failure Terminology**

- 15.1 *R* indicates the failure is in the rubber.
- 15.2 *RC* indicates the failure is at the rubber-cover cement interface.
- 15.3 *CP* indicates the failure is at the cover cement-prime cement interface.
- 15.4 *M* indicates the failure is at the metal-prime cement interface.

NOTE 4—Example—The percentages of the various types of failure may be estimated as in the following examples:

*R*-50, *RC*-50 means that roughly one half or 50 % of the area showed failure in the rubber and the other 50 % showed failure at the rubber-cover cement interface.

*R*-25, *RC*-25, *M*-50 means that three types of failure are present with the *M* indicating 50 % failure at the metal-primer interface.

**16. Apparatus**

16.1 *Testing Machine*—A power driven test machine equipped to produce a uniform rate of grip separation shall be used for measuring the strength of adhesion. The head of the machine shall travel at the uniform rate of 0.83 ± 0.08 mm/s (2 ± 0.2 in./min).

16.2 *Fixture*—Any suitable fixture for holding the test specimen to the upper head of the machine may be used provided the direction of pull to cause separation shall be, at all times during the test, as nearly perpendicular as possible, that is, making a 90° angle with the top holding fixture. The test fixture shown in operation in Fig. 5 complies with the above and provides the ease and simplicity of testing.<sup>8</sup>

16.3 *Grips*—Any suitable grip may be used, provided it does not slip or rupture the rubber strip. The grip shown in Fig. 5 complies and provides ease and simplicity of operation.

<sup>8</sup> Complete detail drawings of the fixture are available at a nominal cost from ASTM, 100 Barr Harbor Drive, Conshohocken, PA 19428. Request ADJD0429.

**ASTM D 429 – 02a**

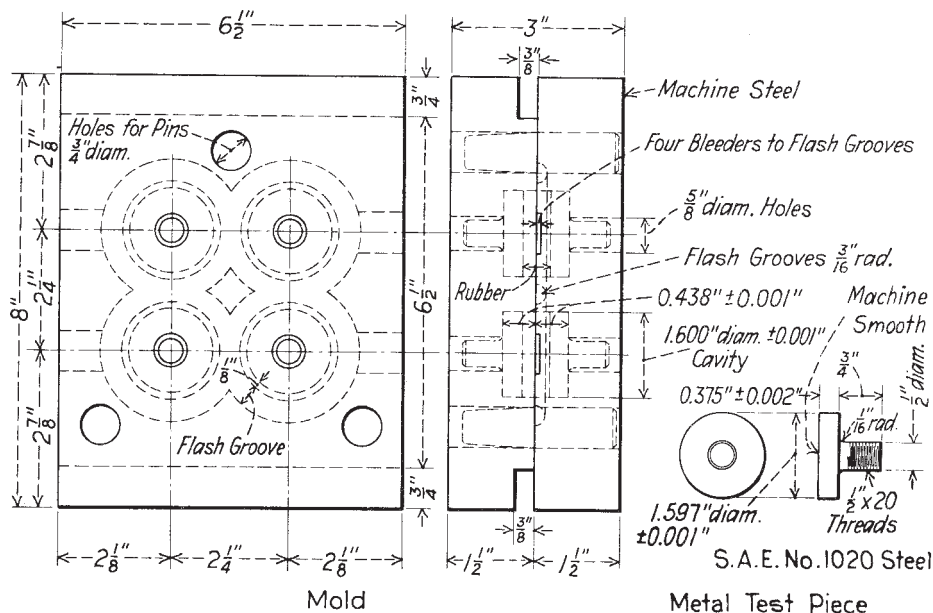

in.	mm
1/16	2
1/8	3
3/16	5
1/4	10
1/2	13
3/8	16
1/2	19
1 1/2	38
2 1/8	54
2 1/4	57
2 7/8	73
3	76
6 1/2	165
8	203
0.375 ± 0.002	9.53 ± 0.05
0.125 ± 0.005	3.2 ± 0.1
1.597 ± 0.001	15.16 ± 0.03
1.600 ± 0.001	40.64 ± 0.03

**FIG. 4 Detailed Drawing of a Mold for Adhesion Test Pieces**

**TABLE 1 Example of Form for Reporting Adhesion test Results**

Stock	Cure	Metal and Metal Finishing Used	Pull		Type of Break, %			
			Sample, lbf/in.	Average, lbf/in.	R	RC	CP	M
Date _____								By _____

**17. Standard Test Specimen**

17.1 The standard test specimen shall consist of a strip of rubber 6.3 ± 0.1 mm (0.250 ± 0.005 in.) in thickness, 25 ± 0.05 mm (1.000 ± 0.002 in.) in width, and 125 mm (5 in.) in length adhered to the face of a metal strip 1.6 ± 0.1 mm (0.062 ± 0.004 in.) in thickness, 25 ± 0.05 mm (1.000 ± 0.002 in.) in width, and 60 ± 1 mm (2.36 ± 0.04 in.) in length. The test specimen shall be so prepared that the bonded area of 25 by 25 mm (1 by 1 in.) is fixed approximately in the middle of the metal member as shown in Fig. 6.

NOTE 5—In cases where the 1.6-mm (0.062-in.) thick metal is perma-

nently deformed during testing, a thicker metal may be used when agreed upon between the purchaser and the supplier.

**18. Preparation of Standard Test Specimen**

18.1 Prepare the standard test specimen as described in 18.1.1 to 18.1.6:

18.1.1 Rectangular metal parts of the standard dimensions described in Section 17 shall have the area to be bonded prepared in accordance with the test method for determining adhesion that may be under investigation. Mask both ends with pressure-sensitive tape so that only the area described in Section 17 will be available for adhesion.

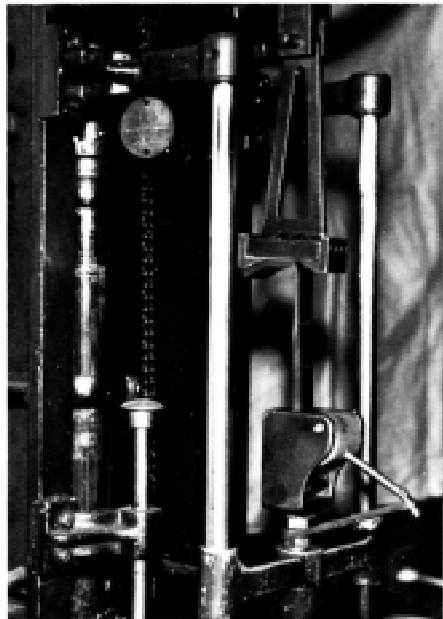

**FIG. 5 Adhesion Tensile Testing Fixture in Operation**

18.1.2 Cut unvulcanized rubber slabs approximately 8 mm (0.3 in.) in thickness to dimensions of the required size for the mold, so as to provide maximum pressure of the rubber against the metal surfaces during vulcanization. (See Fig. 6 for suitable mold design.) The inside mold dimensions parallel to the longitudinal axis of the metal part shall be 125 mm for nominal 5 in. The dimension along the transverse axis of the metal part can be altered according to the number of pieces required for any one cure. This will leave sufficient length of rubber strip for fastening in the grip shown in Fig. 5. Solvent-wash rubber surface to be adhered or treat in accordance with the method being investigated. Freshly milled rubber need not be solvent wiped.

18.1.3 Assemble the metal parts and rubber pieces for vulcanization as shown in Fig. 6, properly spacing the metal parts along one edge of the rubber slab and then placing the assembly, metal parts down, in the mold cavity. Cure the whole assembly in accordance with the method being investigated. Prior to assembly and vulcanization, take great care to keep the surfaces to be adhered clean and free of dust, moisture, or other foreign material.

18.1.4 Vulcanize by heating the mold under pressure for a definite time at a controlled temperature in a hydraulic vulcanizing press. The time and temperature of cure shall be in accordance with the system being investigated. At the conclusion of the cure, take care in removing the specimens from the mold to avoid subjecting the adhered surfaces to stress before the specimens have cooled.

18.1.5 After vulcanization, store the specimens at a temperature of  $23 \pm 2^\circ\text{C}$  ( $73.4 \pm 3.6^\circ\text{F}$ ) for at least 16 h.

18.1.6 Separate the specimens from each other in preparation for testing. This is done by cutting with a scissors, handknife, or other suitable equipment. The edges of the specimen may then be buffed on a belt sander to bring the edge of the rubber flush with the edge of the metal strips (Note 6).

Take care not to overheat the metal parts or the rubber and not to reduce the width of the sample being tested beyond the tolerances described.

NOTE 6—Present experience indicates negligible differences in results between samples buffed clean and samples tested without buffing, because edges of metal parts are not specifically prepared for adhesion and the edge contact area, given a metal part thickness of 1.6 mm (0.062 in.) is not significant.

## 19. Procedure

19.1 Place the test specimen (Note 7) symmetrically in the jaws attached to the fixed grip with the separating edge toward the operator, as shown in Fig. 5. Before the load is applied, strip the rubber from the metal plate for a distance of approximately 2 mm (0.08 in.) by using a sharp knife (Note 8). Place the tab in the grip and apply a steady load at the rate of 50 mm (2.0 in.)/min until separation is complete. Use the autographic recorder in order to show graphically the adhesion values over the full length of the test specimen.

NOTE 7—This specimen lends itself to the determination of the relative effect of environmental conditions on possible bond deterioration. Specimens may be exposed unstressed or under a constant, relatively low bond stress. It is recommended that one of the standard ASTM environmental exposure conditions be used. Among those applicable are the following: Test Methods D 471, D 572, D 573, D 1149, Practice G 23, and Method B 117. If environments other than the above are used, they shall be described completely. This should include the conditions of the exposure such as time, temperature, etc.

NOTE 8—Stripping the rubber from the plate initially, and as necessary during the test, is done to observe more clearly adhesion to the substrate rather than the tear strength of the stock.

## 20. Calculations

20.1 Express the adhesion value in newtons per millimetre or pounds-force per inch of width.

## 21. Report

21.1 The report shall include the following, preferably reported on an Adhesion Test Data Sheet illustrated in Table 1:

21.1.1 The results calculated in accordance with Section 20.

21.1.2 All observed and recorded data,

21.1.3 Notation of the type or types of failures and the estimated percentages of the various types of failures (Section 15),

21.1.4 Description of the specimen including statement of method of determining adhesion, if known,

21.1.5 Date of vulcanization, if known,

21.1.6 Time and temperature of vulcanization, if known,

21.1.7 Temperature of test room, and

21.1.8 Date of test.

## 22. Precision and Bias <sup>7</sup>

22.1 Precision and bias do not exist for this test method because resources necessary for round-robin testing have not been forthcoming.

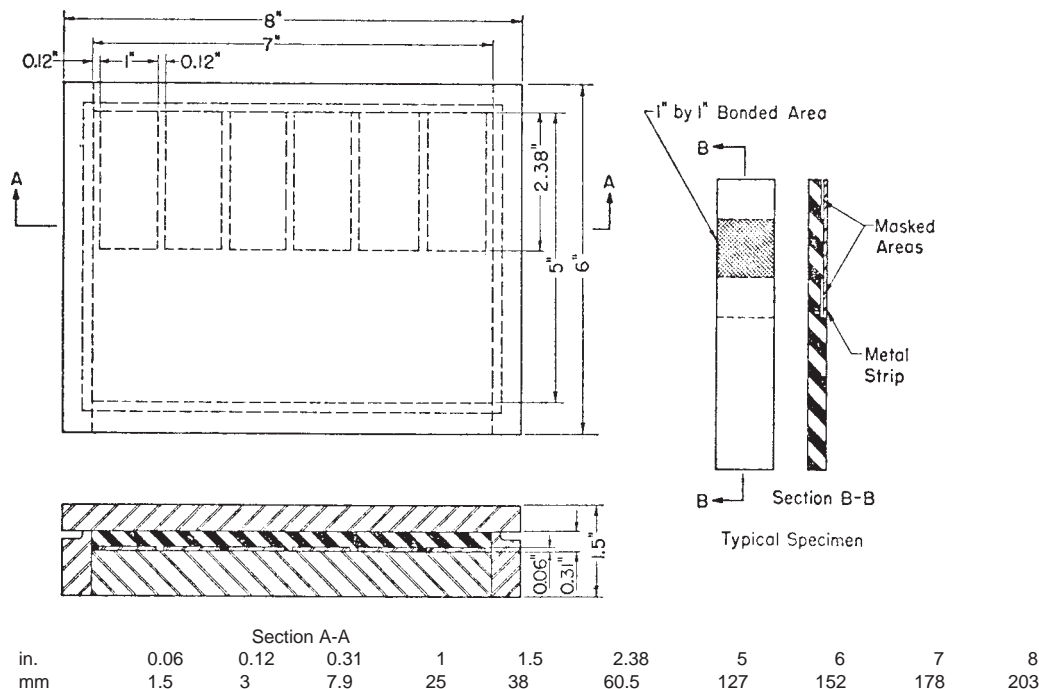

**FIG. 6 Adhesion Test Specimen Mold**

## METHOD C—MEASURING ADHESION OF RUBBER-TO-METAL WITH A CONICAL SPECIMEN

### 23. Significance and Use

23.1 The test method is designed primarily for application to test pieces prepared in the laboratory under standard conditions in order to provide data for development and control of bonding systems and their components such as cements, or special rubber compounds, and of test methods of manufacture. While intended to be applied where rubber is bonded to supporting rigid pieces, it may not cover such cases where the support, while being of high modulus material, has a low rigidity due to small transverse dimensions, as in the case of rubber bonded to metal wires, cords or thin sheets. The particular geometry of the test piece produces, in most cases, an interfacial failure between the rubber and conical part, because of a stress concentration at the tip of the cone.

### 24. Adhesion Failure Terminology

24.1 Express the type of adhesion failure as determined by examination of broken test pieces by one or more of the following symbols:

24.2 *R* indicates failure in the rubber.

24.3 *RC* indicates failure in the rubber-cover cement.

24.4 *CP* indicates failure in the cover cement-prime cement.

24.5 *M* indicates failure in the prime cement-metal interface.

NOTE 9—*Example*—The percentages of the various types of failure may be estimated as in the following examples:

*R-50, RC-50* means that roughly one half or 50 % of the area showed

failure in the rubber and the other 50 % showed failure at the rubber-cover cement interface.

*R-25, RC-25, M-50* means three types of failure present with the *M* indicating 50 % failure at the metal primer interface.

### 25. Apparatus

25.1 *Testing Machine*—A tension testing machine conforming to the requirements of Practices E 4 shall be used for measuring the strength of adhesion. The moving head of the machine shall travel at the rate of  $0.83 \pm 0.08$  mm/s ( $2.0 \pm 0.2$  in./min). The machine shall be provided with a recording device to give the force in newtons or pounds-force at the conclusion of the test. A machine of not more than 40 kN or 10 000 lbf capacity will be found suitable in most cases.

25.2 *Grips*—The fixtures for holding the specimen in the test machine will depend on the type of specimen but in all cases shall be provided with ball seats to permit proper centering of the applied load during the test. These grips can be of two types: (1) a simple slip-in type which engages in the grooved section of the conical specimen, or (2) a threaded stud with a locknut. This could be a combination fixture.

### 26. Standard Test Specimen

26.1 A standard test specimen shall consist of a rubber compound bonded to two conical metal end pieces. The diameter of the test specimen shall be  $25 \pm 0.5$  mm ( $1.00 \pm 0.2$  in.). The distance between the opposed conical end pieces shall be  $11.5 \pm 1.2$  mm ( $0.45 \pm 0.05$  in.). For the test specimen in Fig. 7, the height of each conical end piece shall be  $23.4 \pm 0.5$  mm ( $0.92 \pm 0.02$  in.) (Note 10). The half-angle of the cone vertex shall be  $45 \pm 1^\circ$  and the tip shall not be rounded to radius greater than 0.8 mm (0.03 in.).

NOTE 10—Theoretically, the height of end pieces could be any length.

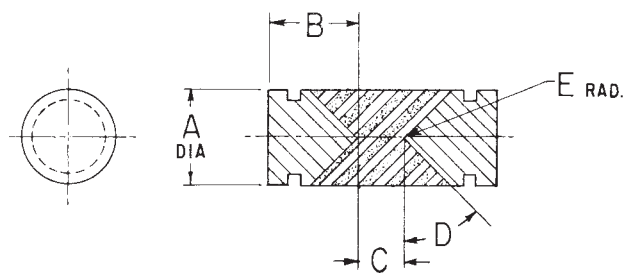

	mm	in.
A	25.0 ± 0.5	1.00 ± 0.02
B <sup>A</sup>	23.5 ± 0.5	0.92 ± 0.02
C	11.5 ± 1.2	0.45 ± 0.05
D	45° ± 1	
E (radius)	0.8 max	0.03 max

<sup>A</sup> Suggested dimension.

**FIG. 7 Test Specimens with Conical Adhesion Areas**

The end pieces in Fig. 7 have been the most practical size for molding and testing.

## 27. Laboratory Preparation of Standard Test Specimens

27.1 The standard test specimen is formed by two cylindrical rigid parts terminated by opposite conical ends, and a cylinder of rubber bonded to the conical ends. Prepare in the laboratory in accordance with 27.1.1 through 27.1.7.

27.1.1 Machine conical metal parts from rolled bar steel SAE No. 1020<sup>7</sup> or SAE No. 1010 for standard reference pieces. However, other rigid materials may be used if in conformity with the essential dimensions to determine the effect of adhesion on other rigid materials. Prepare the test face of the

cone in accordance with any test method for securing adhesion that may be under investigation.

27.1.2 Vulcanize the specimens in a transfer mold. For the six-cavity transfer mold shown in Fig. 8, the unvulcanized rubber piece shall be approximately 20 mm (0.8 in.) in thickness and 110 mm (4.3 in.) in diameter. Sufficient rubber stock should be used to fill the pot and provide some excess after filling the mold cavities.

27.1.3 Clean or treat the surface of the conical ends in accordance with the adhesion system under investigation. Coat the treated metal surface with the adhesive over the conical area only.

27.1.4 Place the rigid parts and the rubber compound in the preheated mold for vulcanization.

27.1.5 Vulcanize with conditions of time, temperature, and pressure being regulated by their interrelationship effect on adhesion to be determined. It may be necessary to surround the mold with an insulating shield to maintain proper temperature during cure.

27.1.5.1 At the conclusion of the cure, take great care when removing the test specimens from the mold to avoid subjecting the bonded surfaces to undue stress before the test specimens have cooled.

27.1.6 After vulcanization, store the specimens at a temperature of 23 ± 2°C (73.4 ± 3.6°F) at least 16 h prior to testing.

27.1.7 Fig. 8 shows a mold, unvulcanized rubber compound, molded test specimens, and adhesive coated conical pieces.

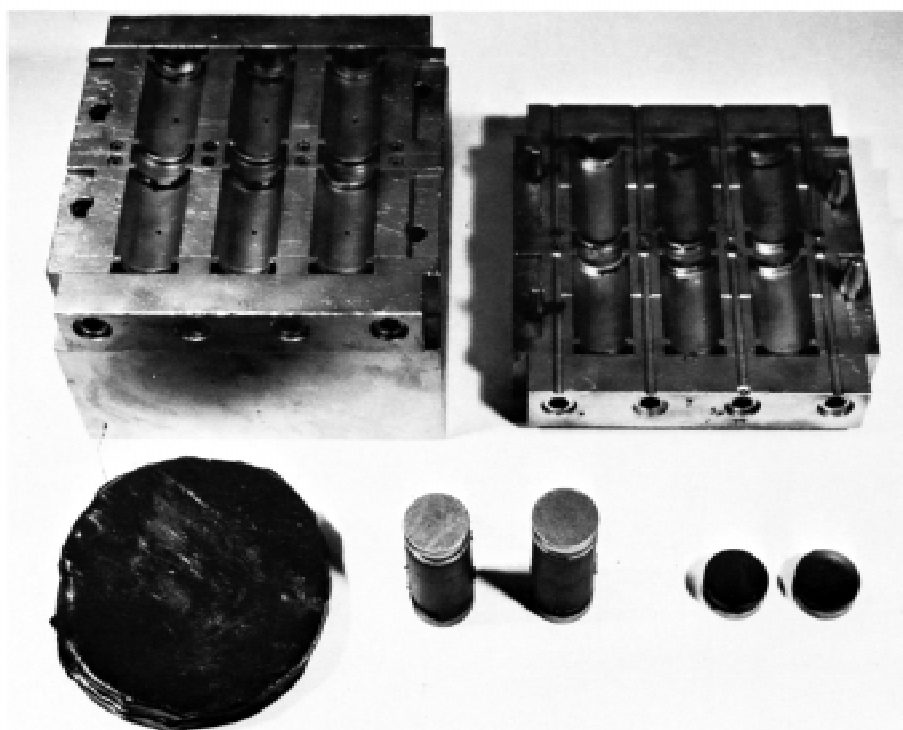

**FIG. 8 Mold and Conical Test Specimens**



## 28. Procedure

28.1 Mount the test specimens in the grips of the test machine using the appropriate fixtures. Take care in centering and adjusting the test specimen so the tension is symmetrically distributed in the cross section during the test. Apply the tension load until the rubber either separates from the adhesive surface or ruptures. Record the total load at the time of failure. Record type or types of failure and express in accordance with the standard adhesion failure terminology (see Section 24).

## 29. Calculations

29.1 Express the adhesion value in newtons or pounds-force required to produce failure. In cases where the failure is in the rubber, the adhesion value is recognized as being higher than that recorded.

## 30. Report

30.1 The report shall include the following, preferably reported on an Adhesion Test Data Sheet illustrated in Table 1:

- 30.1.1 Type and code number of the rubber compound,
- 30.1.2 Cure time and temperature,
- 30.1.3 Type of metal or rigid substrate used and surface preparation,
- 30.1.4 Adhesive and dilution,
- 30.1.5 The adhesion value for each test piece,
- 30.1.6 Type and percentage of failure,
- 30.1.7 Date of vulcanization and date of test, and
- 30.1.8 Temperature of test room.

## 31. Precision and Bias

31.1 Precision and bias do not exist for this test method because resources necessary for round-robin testing have not been forthcoming.

## 32. Salvaging of Bonded Metal Parts

32.1 Bonded metal parts may be salvaged by the usual burning or chemical stripping techniques. Mechanical or chemical surface treatments are used to re-establish a clean bonding surface. The sharpness of the conical tip may be reduced during salvaging. This affects reproducibility of the test results and care must be taken to re-establish the sharpness of this cone to 0.8-mm (0.03-in.) radius (maximum).

### **METHOD D—ADHESION TEST: POST-VULCANIZATION (PV) BONDING OF RUBBER TO METAL**

## 33. Significance and Use

33.1 Methods A, B, and C of this standard cover procedures for testing the strength of adhesion of rubber to metal when the bond is formed during vulcanization. Method D may be used to determine the strength of adhesion of rubber to metal when the bond is formed after the rubber has been vulcanized. In the rubber industry, this is commonly referred to as post-vulcanization (PV) bonding.

33.2 In the test, a vulcanized circular disk that has been adhesive coated on both ends, is assembled between two parallel metal parts. The rubber-metal assembly is then placed

in a jig under compression and heated in an oven for a specified time at a specified temperature.

33.3 When tested to rupture in an axial direction, a measurement of rubber-to-metal adhesion is obtained. The rupture force and type of failure are recorded.

## 34. Apparatus

34.1 *Testing Machine*, A tension testing machine conforming to the requirements of Practices E 4 shall be used for measuring the strength of adhesion. The crosshead of the machine shall travel at the rate of  $0.83 \pm 0.08$  mm/s ( $2.0 \pm 0.2$  in./min). The machine shall be provided with a device to record the maximum force at the conclusion of the test. A machine of at least 40 kN (10 000-lbf) capacity is suitable.

34.2 *Grips*—The fixtures for holding the specimen in the testing machine will depend on the type of specimen but in all cases shall be provided with ball seats to permit proper centering of the load during the test. These grips can be of the type described in 6.2 of Method A and illustrated in Fig. 1 and Fig. 3.

34.3 Details of the apparatus used to hold and compress the rubber metal bonded assembly during oven cure are shown in Fig. 9 (outside plates) and Fig. 10 (center aligning plate). The center aligning plate, which controls compression of the bonded assembly to  $10.0 \pm 0.1$  %, is held to the outside plates by means of two bolts, washers, and nuts. The bolts are tightened until the metal pieces compress the rubber properly.

## 35. Standard Test Specimens

35.1 Prepare the vulcanized rubber test specimen in accordance with the procedure given in Test Method D 395.

35.2 The metal test specimen is identical to the standard metal test specimen described in Section 6, Method A, of this standard.

## 36. Preparation of Standard Test Specimens

36.1 Place vulcanized rubber test specimens in a suitable open basket and vapor degreased (with perchloroethylene) for a period approaching, but not exceeding, 5 min. Remove the rubber specimens and allow to air dry at Standard Laboratory Temperature ( $23 \pm 2^\circ\text{C}$ ) for a period of at least 30 min. This should be in a dust-free area, preferably at low relative humidity.

36.2 Soak lint-free paper towel in mineral spirits (varnish and paint makers naphtha) and lay flat on a clean surface. Wipe the rubber surfaces to be bonded several times across the paper to remove any residual surface contaminants. Following air-drying for at least 15 min, post-dry the cleaned rubber specimens for 10 min at  $70^\circ\text{C}$  in a circulating air oven. Remove the rubber specimens from the oven and allow to condition at Standard Laboratory Temperature ( $23 \pm 2^\circ\text{C}$ ) for at least 30 min prior to adhesive coating, preferably by brush application.

36.3 Dip each surface of the adhesive-coated specimen alternately into a suitable assembly oil<sup>9</sup> to a depth slightly

<sup>9</sup> Rubber assembly oil—Ex. Seagul Type R, Clark Oil and Chemical Co., Cleveland, OH.

**ASTM D 429 – 02a**

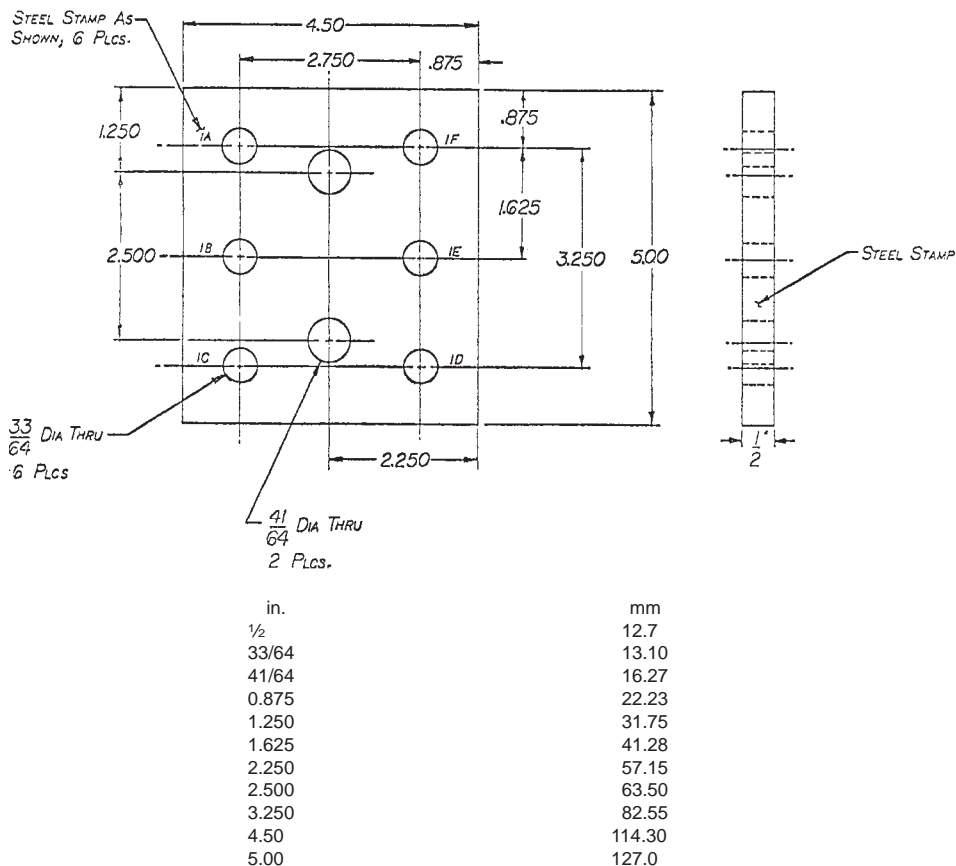

**FIG. 9 Outside Plates (Two Required) Low-Carbon Steel**

greater than the surface to be covered. Place the specimen on its side and allow excess oil to drain off for about 5 min prior to assembly.

36.4 Assemble the test unit in accordance with Fig. 11. Required compression is automatically obtained by the spacer as the unit is tightened.

36.5 Place the test unit in a circulating air oven at 150°C for a period of 60 ± 10 min, or at a time and temperature recommended by the adhesive supplier. Remove the unit and immediately cool in room temperature tap water for at least 20 min. Following cooling, disassemble the test unit and store the individual test specimens at a temperature of 23 ± 2°C at least 48 h prior to testing.

**37. Procedure**

37.1 Attach the bonded assembly to the tension testing machine using the appropriate fixtures or grips. Apply a force until destruction of the bonded assembly is complete. Record the type of failure, expressed in accordance with the adhesion failure terminology described in Section 4 under Method A of this standard.

**38. Calculations**

38.1 Express the adhesion value in pascals (or kPa, MPa) or pounds-force per square inch and calculate by dividing the

tension force by the original area of the adhered surface. In the case of rupture of the rubber, the adhesion value is recognized as being higher than the rupture strength that is calculated as described above.

**39. Report**

39.1 The report shall include the following, preferably reported on an Adhesion Test Data Sheet illustrated in Table 1:

- 39.1.1 Type and code number of the rubber compound,
- 39.1.2 Bonded assembly preparation; cure time and temperature,
- 39.1.3 Type of metal and surface preparation,
- 39.1.4 Adhesive and dilution,
- 39.1.5 Method of application,
- 39.1.6 Failure or rupture stress measured in pascals or pounds-force per square inch,
- 39.1.7 Type of failure, and
- 39.1.8 Date of test.

**40. Precision and Bias <sup>7</sup>**

40.1 Precision and bias do not exist for this test method because resources necessary for round-robin testing have not been forthcoming.

**ASTM D 429 – 02a**

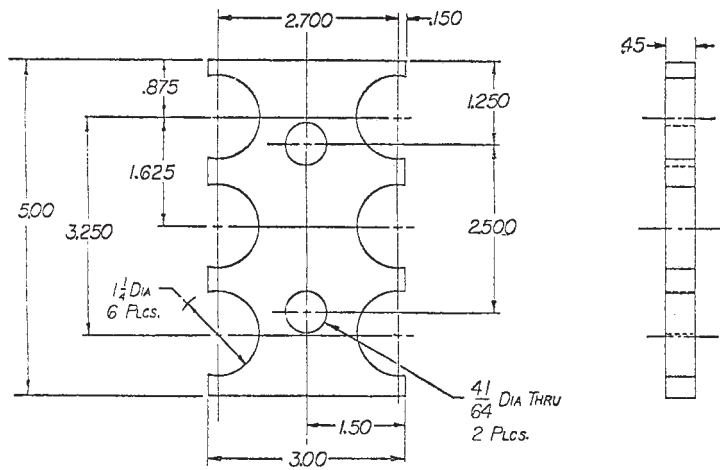

in.	mm
0.150	3.81
0.45	11.40
41/64	16.27
0.875	22.23
1 1/4	31.75
1.250	31.75
1.50	38.10
1.625	41.28
2.500	63.50
2.700	68.58
3.00	76.20
5.00	127.00

**FIG. 10 Center Aligning Plate (One Required) Low-Carbon Steel**

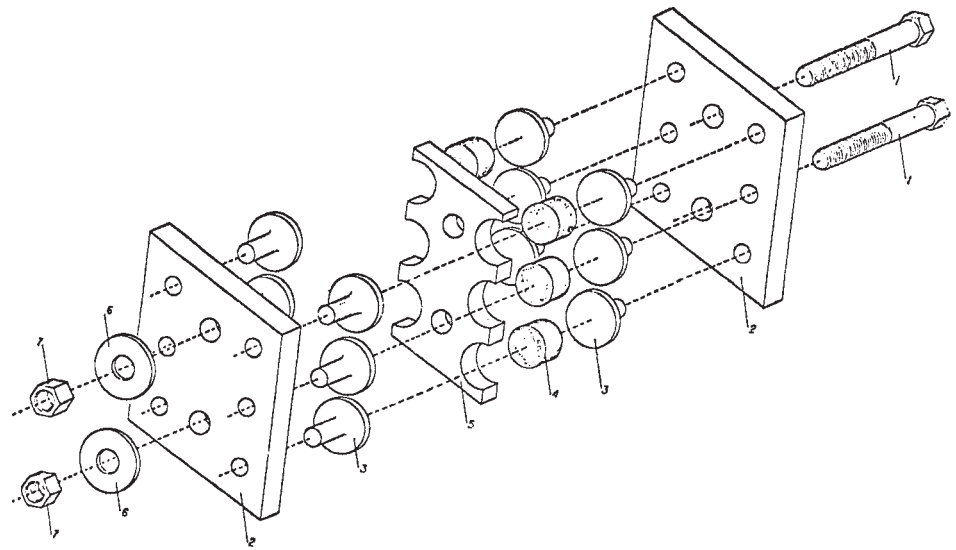

**PARTS LIST**

No.	Description	No. Req'd
1	5/16-16 UNC 3-in. long hex bolt	2
2	Fig. 9 – outside plate	2
3	Metal test specimen	12
4	Vulcanized rubber puck	6
5	Fig. 10 – center aligning plate	1
6	Washer	2
7	5/16-16 UNC nut	2

**FIG. 11 Total Assembly**

## METHOD E—90° STRIPPING TEST—RUBBER TANK LINING—ASSEMBLED TO ONE METAL PLATE

### 41. Significance and Use

41.1 This test is intended for determining the adhesive strength of rubber tank lining to tank wall after procedures similar to what would occur in actual practice. The results are obtained by measuring the pull necessary to separate a rubber strip from a metal surface. The data obtained indicate the strength of adhesion along a line across the width of the rubber strip being separated from a plate at a 90° angle. The test provides valuable data for development and control of rubber compounds and methods of bonding. It also serves as a screening test for the evaluation of various bonding agents, or techniques, or both.

### 42. Adhesion Failure Terminology

42.1 *R* indicates the failure is in the rubber.

42.2 *RC* indicates the failure is at the rubber-cover cement interface.

42.3 *CP* indicates the failure is at the cover cement-prime cement interface.

42.4 *M* indicates the failure is at the metal-prime cement interface.

*NOTE 11—Example—*The percentages of the various types of failure may be estimated as in the following examples:

*R-50, RC-50* means that roughly one half or 50 % of the area showed failure in the rubber and the other 50 % showed failure at the rubber–cover cement interface.

*R-25, RC-25, M-50* means that three types of failure are present with the *M* indicating 50 % failure at the metal – primer interface.

### 43. Static-Mass Method (SM)

43.1 *Apparatus:*

43.1.1 The apparatus required for the adhesion test by the static-mass test method consists of a supporting frame, testing clamps, calibrated masses, and a mass carrier.

43.1.2 The frame has sufficient height to permit the mass carrier to be suspended from the clamp holding the test specimen and to hang freely during the progress of the test.

43.1.3 A photograph of a suitable support frame, together with test specimen, clamp, mass carrier, and calibrated masses, is shown in Fig. 12.

### 44. Standard Test Specimen

44.1 A standard test specimen is shown in Fig. 13 and the 25 ± 0.05-mm (1.000 ± 0.002-in.) wide strip of rubber is fixed approximately in the center of the metal plate. Overall size of the prepared test specimen from which the 25 mm wide strip is taken is 150 ± 3 mm (6.000 ± 0.15 in.) square. One end of the cemented plate is to be masked with approximately 25 mm (1 in.) wide pressure-sensitive tape.

### 45. Laboratory Preparation of Standard Test Pieces

45.1 The standard test specimens shall be as described in 45.1.1 to 45.1.4.

45.1.1 Prepare contact area of hot-rolled, mild black steel in accordance with the method for securing adhesion that is specified by supplier, or that may be under investigation. Size

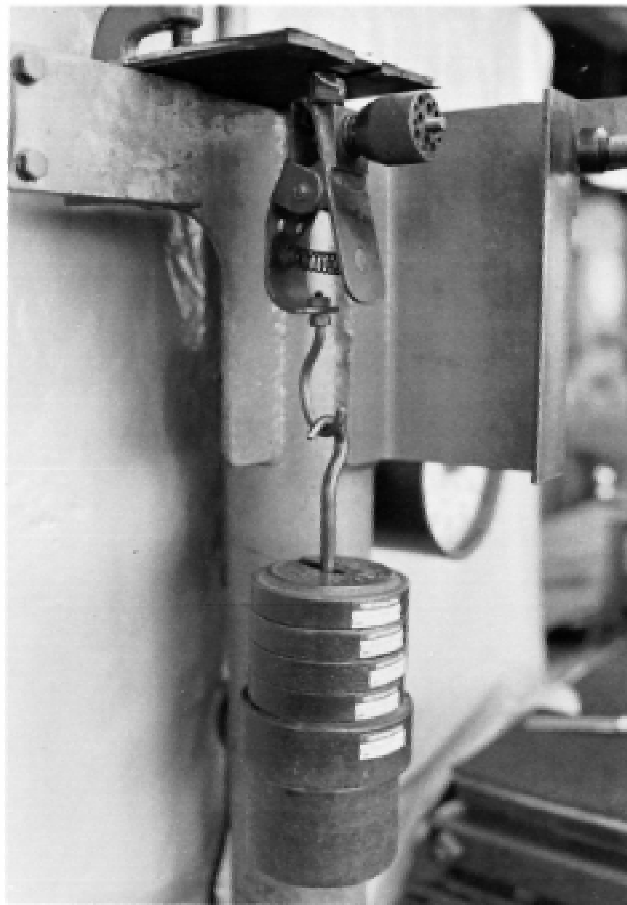

**FIG. 12 Test Apparatus For Static Mass Adhesion Test on Rubber Tank Lining**

of metal plate is 150 (6 in.) square and at least 3.4 mm (0.13 in.) in thickness. Mask one end with approximately 25 mm (1.0 in.) wide pressure-sensitive tape.

*NOTE 12—*In cases where the 3.18-mm (0.135-in.) thick metal is permanently deformed during testing, a thicker metal plate may be used. Likewise, a different grade of steel may be specified when agreed upon between the purchaser and the supplier.

45.1.2 Apply unvulcanized rubber slabs, 6.3 ± 0.5 mm (0.25 ± 0.02 in.) thick to the prepared surface of the metal plate.

*NOTE 13—*Other thickness of rubber may be used to correspond to actual ordered gage of tank lining stock if so noted on test report.

45.1.3 Vulcanize the rubber in the same manner as recommended by the rubber tank lining manufacturer; that is, cured by exhaust steam, steam pressure, or chemical cure and recommended time, temperature, and procedure.

45.1.4 After vulcanization, store the specimens at a temperature of 23 ± 2°C (73.4 ± 3.6°F) at least 16 h. Cut a 25-mm wide strip as shown in Fig. 9.

### 46. Procedure

46.1 Separate the part to be tested by hand at the masked area end and at a sufficient distance to permit jaws of the testing clamp to be attached. Mount the plate on a support

ASTM D 429 – 02a

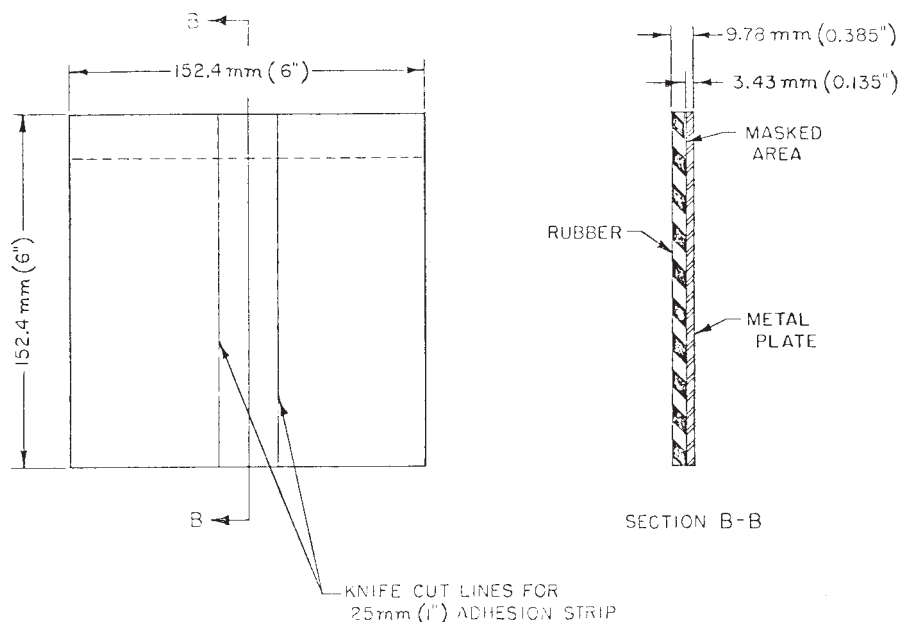

FIG. 13 Adhesion Test Specimen for Rubber Tank Lining



FIG. 14 An Example of a Rubber Tank Lining Adhesion Specimen in a Testing Machine

frame, attach a clamp to the test specimen at separated end. Suspend a mass carrier to the clamp and apply known masses to the carrier until the mass causes a constant rate of travel of 0.4 mm/s (1 in./min) throughout the test.

#### 47. Machine Method (M)

##### 47.1 Apparatus:

47.1.1 *Testing Machine*—A testing machine as described in 6.1 of Test Methods D 412 shall be used for measuring the strength of adhesion. The head of the machine shall travel at the uniform rate of 50 mm (2.0 in.)/min.

47.1.2 *Fixture*—Any suitable fixture for holding the test specimen to the upper head of the machine may be used

provided the direction of pull to cause separation shall be, at all times during the test, as nearly perpendicular as possible, that is, making a 90° angle with the top holding fixture. The test fixture shown in operation in Fig. 5 complies with the above and provides ease and simplicity of testing.

47.1.3 *Grips*—Any suitable grip may be used, provided it does not slip or rupture the rubber strip. The grip shown in Fig. 5 complies and provides ease and simplicity of operation.

#### 48. Standard Test Specimen

48.1 Refer to 44.1 (same as used for static-mass test method).

## 49. Laboratory Preparation of Standard Test Pieces

49.1 Refer to 45.1 through 45.1.4. (Same as used for static-mass test method).

## 50. Procedure

50.1 Place the test specimen (Note 14) symmetrically in the jaws attached to the fixed grip with the separating edge toward the operator, as shown in Fig. 5. Before the load is applied, strip the rubber from the metal plate for a distance of approximately 2 mm ( $\frac{1}{16}$  in.) by using a sharp knife (Note 15). Place the tab in the grip and apply a steady load at the rate of 50 mm (2.0 in.)/min until separation is complete. Use autographic recorder in order to show graphically the adhesion values over the full length of the test specimen.

NOTE 14—This specimen lends itself to the determination of the relative effect of environmental conditions on possible bond deterioration. Specimens may be exposed unstressed or under a constant, relatively low bond stress. It is recommended that one of the standard ASTM environmental exposure conditions be used. Among those applicable are the following: Test Methods D 471, D 572, D 573, D 1149, Practice G 23, and Method B 117. If environments other than the above are used, they shall be described completely. This should include the conditions of the exposure such as time, temperature, etc.

NOTE 15—Stripping the rubber from the plate initially, and as necessary during the test, is done to observe more clearly adhesion to the substrate rather than the tear strength of the stock.

## 51. Precautions

### 51.1 Tearing:

51.1.1 If, during a test, one of the parts begins to tear instead of separating from the other part of the specimen, cut the material being torn with a knife up to the surface of contact between the two parts and start the test again.

51.1.2 If one of the parts repeatedly tears, instead of separating from the other part, a satisfactory result may be secured in the static-mass test method by reducing the amount of the mass used if this is permitted. In case of repeated tearing when using the machine test method, take as the result of the test the average load at which tearing occurs.

51.2 *Effect of Temperature*—The results of this test are affected by temperature. Elevating the temperature causes a faster rate of stripping under a given load. The temperature during test shall therefore be  $23 \pm 2^\circ\text{C}$  ( $73.1 \pm 3.6^\circ\text{F}$ ) and the actual temperature shall be recorded.

## 52. Calculations

52.1 For the static-mass test method, report the adhesion value as separation rate per unit width under a stated force, as follows:

\_\_\_ mm/s. for 25-mm width under \_\_\_ N force  
\_\_\_ in./s for 1-in. width under \_\_\_ lbf

If a width other than 25 mm (1 in.) was used, correct the separation by multiplying the rate by the quotient of actual width per desired width as follows:

or \_\_\_ mm/25 mm  
\_\_\_ in./1 in.

Include both the rate and the actual width in the report.

For the machine test method, the autographic chart constitutes the report, but the value of the adhesion is determined by drawing on the chart the best average line between the

maximum and minimum force values. The force so indicated, expressed in newtons per metre (or pounds-force per inch) is divided by the width measured in 10.1 for separation at the rate used and is reported as the adhesion value, as follows:

$$N/m \text{ (lbf/in.)} = \text{force/actual width} \quad (1)$$

Show both the force and actual width in the report.

## 53. Interpretation of Results

53.1 In the static-mass test method, no stripping is started unless a certain mass is used. Small increments in mass do not progressively cause proportional increases in rate of separation. With increasing mass the rate increases slowly at first and finally very rapidly. Rate of separation must therefore be interpreted carefully. A specimen required to separate not more than 0.4 mm/s (1 in./min) under a force of 90 N (20 lbf) might be regarded as very inferior if the test result was 2 mm/s (5 in./min). The same specimen might not strip at all under a force of 67 N (15 lbf) and might meet the requirement with a force of 80 N (18 lbf).

53.2 The true adhesion value is not determined in case the specimens repeatedly tear. The test, however, indicates that the strength of adhesion exceeds the strength of the material and that the adhesion value is not less than the result obtained. In cases of tearing, the results should be so designated.

53.3 Adhesion values may differ between different plies of the same article of plied construction and also at different points along the same ply. The adhesion value of one ply to another is taken as the average result of the test over a reasonable distance of separation. When possible, a distance of separation of at least 100 mm (4 in.) shall be used.

## 54. Report

54.1 The report shall include the following:

54.1.1 Results of the adhesion test expressed in accordance with Sections 53 and 52,

54.1.2 All observations and recorded data on which the results are based,

54.1.3 Date of manufacture or vulcanization of rubber, if known,

54.1.4 Date of test,

54.1.5 Statement of the test method used (static-mass or machine),

54.1.6 Temperature of test room, and

54.1.7 Dimensions of the test specimen.

## 55. Precision and Bias <sup>7</sup>

55.1 Precision and bias do not exist for this test method because resources necessary for round-robin testing have not been forthcoming.

## METHOD F—RUBBER PART ASSEMBLED BETWEEN TWO PARALLEL CONVEX-SHAPED METAL PLATES

## 56. Significance and Use

56.1 Method F is used for determining the adhesive strength of rubber-to-metal bonding agents. The adhesion values are obtained by measuring the force in an axial direction that is

necessary to separate the bonded rubber from the metal component. The metal component is composed of two parallel metal test specimens that have a convex shape on the bonded side. (Fig. 15). This particular geometry produces in many instances, interfacial failure(s) and thus is a discriminatory screening test for the agents.

**57. Adhesion Failure Terminology**

57.1 Express the type of adhesion failure as determined by examination of broken test pieces by one or more of the following symbols:

57.2 *R* Indicates failure in the rubber (substrate failure).

57.3 *RC* indicates failure in the rubber-cover cement (interfacial failure).

57.4 *CP* indicates failure in the cover cement-prime cement (interfacial failure).

57.5 *M* indicates failure in the prime cement-metal interface (interfacial failure).

NOTE 16—*Example*—The percentage of the various types of failure may be estimated as in the following examples:

R-60, RC40 means that 60 % of the bonded area showed failure in the rubber and the other 40 % showed failure at the rubber-cover cement interface.

R-25, RC-25, M-50 means that three types of failure are present with R indicating 25 % failure in the rubber, RC, 25 % failure between the rubber and the cement(adhesive)interface, and 50 % failure at the metal-primer interface, 25 % in the rubber.

**58. Apparatus**

58.1 *Testing Machine*—A testing machine as described in 6.1 of Test Methods D 412 shall be used for measuring the strength of adhesion. The head of the machine shall travel at the uniform rate of  $0.83 \pm 0.08$  mm/s ( $2 \pm 0.2$  in./min). The machine shall be provided with a recording device to give the force in newtons or pounds-force at the conclusion of the test.

58.2 *Fixture*—The fixtures for holding the specimen in the test machine shall be threaded so the threaded studs of the test specimen can be screwed into the grip. Fixtures may be provided with ball seats to permit proper centering of the load during the test.

**59. Standard Test Specimen**

59.1 A standard test specimen shall consist of a rubber compound bonded to two convex-shaped metal end pieces. The diameter of each test specimen shall be  $28.70 \pm 0.76$  mm. The distance between the pieces shall be  $25.00 \pm .76$  mm, the radius  $41.3 \pm 0.25$  mm. (see Fig. 15).

**60. Laboratory Preparation of Test Specimens**

60.1 The standard test specimen is formed by vulcanizing the desired type of rubber in a mold containing the adhesive coated metal test parts. Injection molding, transfer molding, or compression molding may be used. Prepare in the laboratory in accordance with 60.1.1-60.1.6.

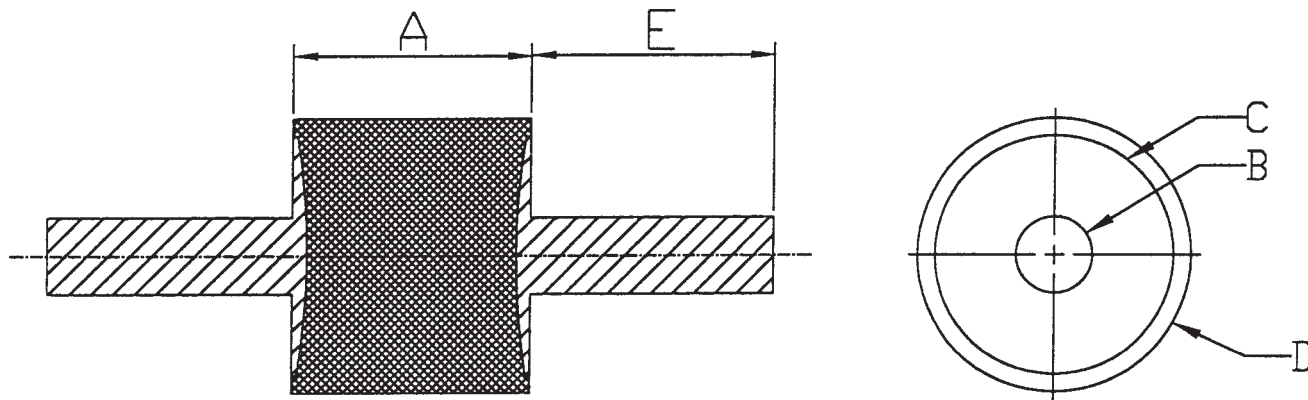

Dimension	Size (mm)
A	25.0 mm ± 0.05 mm
B	8 mm x 1.25 thread
C	25.0 mm ± 0.76 mm
D	28.7 mm ± 0.76 mm
E	25.4 mm ± 0.76 mm
Radius of Surface	41.3 mm ± 0.25 mm

FIG. 15 Test Specimen

60.1.1 Machine the metal test part from rolled bar steel SAE No. 1020 or SAE No. 1010 for standard reference pieces. Other rigid materials may be used if in conformity with the essential dimensions.

60.1.2 Prepare the test face of the specified convex specimen in accordance with any test method for securing adhesion that may be under investigation (for example, phosphated treated, mechanical blasted, etc).

60.1.3 Coat the prepared metal surface with the adhesive system to be tested in accordance to the manufacturers recommendations.

60.1.4 Place the dry adhesive coated specimens in the mold. For compression or transfer molding, place the rubber preforms in the mold cavity. For injection molding, inject the rubber into the mold.

60.1.5 Vulcanize with conditions of time, temperature, and pressure in accordance with the system being investigated.

60.1.6 After a suitable vulcanization cycle, remove the specimens with care to avoid subjecting the adhered surfaces to stress before the specimens have cooled. Store the specimens at a temperature of  $23 \pm 2^{\circ}\text{C}$  ( $73 \pm 4^{\circ}\text{F}$ ) at least 16 h prior to testing.

60.2 Fig. 16 shows a photograph of a mold and inserts.

## 61. Procedure

61.1 Mount the test specimens in the threaded grips of the test machine. Apply the tension load until the rubber either separates from the adhesive surface or the rubber ruptures.

Record the total load at the time of failure. Observe the record the type or types of failure and express in accordance with the standard adhesion failure terminology (see Section 57).

## 62. Calculation

62.1 Express the adhesion value in newtons (N) or pounds-force (lbs) required to produce failure. In cases where the failure is in the rubber, the adhesion value is recognized as being higher than that recorded.

## 63. Report

63.1 The report shall include the following, preferably reported on an Adhesion Test Data Sheet illustrated in Table 1:

- 63.1.1 Type and code number of the rubber compound,
- 63.1.2 Cure time and temperature,
- 63.1.3 Type of metal or rigid substrate used and surface preparation,
- 63.1.4 Molding method used (compression, injection, etc.)
- 63.1.5 Adhesive used, dilution, and application method,
- 63.1.6 The adhesion value for each test piece,
- 63.1.7 Type and percentage of failure,
- 63.1.8 Date of vulcanization and date of test, and
- 63.1.9 Temperature of test room and humidity.

## 64. Precision and Bias

64.1 Precision and bias do not exist for this test method because resources necessary for round-robin testing have not been forthcoming.

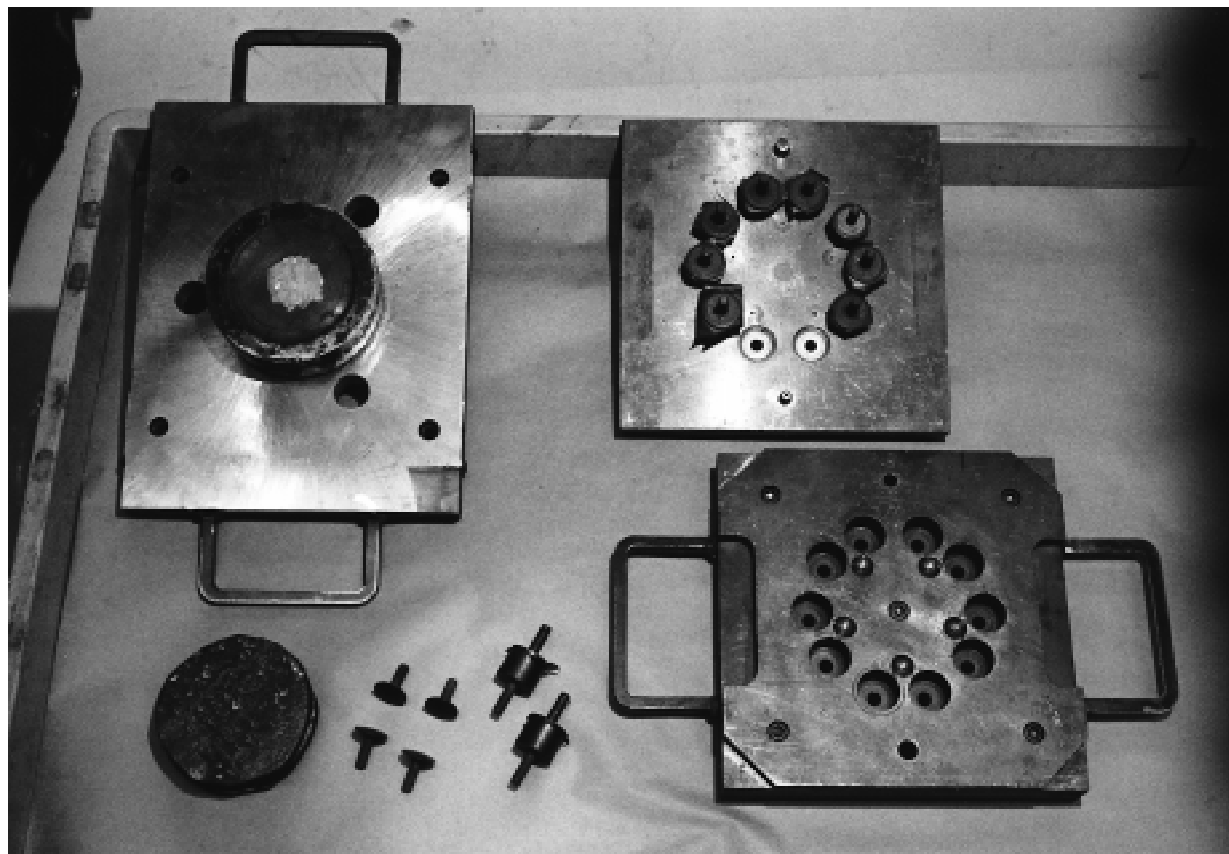

**FIG. 16 Test Mold and Test Specimens**



**METHOD G—MEASURING BOND DURABILITY FOR RUBBER-TO-METAL BONDED COMPONENTS WITH A DOUBLE SHEAR CYLINDRICAL SPECIMEN**

**65. Significance and Use**

65.1 Method G is used for determining relative bond durability between various adhesives. The adhesives to be compared are used to bond rubber-to-metal using a double shear cylindrical specimen (see Fig. 17) which is then placed in a fixture to impart a shear stress on the bond line. This assembly (see Fig. 18) is then placed in the prescribed test medium and the time to obtain a failure depth of 5 mm at the rubber-metal bond interface is noted. With this test, the durability of a specific adhesive as a function of changes in the rubber formulation may be studied. Different adhesives may be examined to find the best for a given rubber recipe. Also, different metal preparations and their effect on bond durability may be investigated.

**66. Adhesion Failure Terminology**

66.1 Express the type of adhesion failure as determined by the visual examination of the of the failed area using one or more of the following symbols:

66.2 *R* indicates failure in the rubber.

66.3 *RC* indicates failure in between the rubber and the adhesive.

66.4 *CP* indicates failure between the adhesive top coat and the primer in the case of a two coat system.

66.5 *M* (or *CM*) indicates failure between the primer (or adhesive in the case of a one coat system) and the substrate, for example, metal.

NOTE 17—*Example*—The percentage of the various types of failure may be estimated as in the following examples:

R-60, RC -40 means that 60 % of the bonded area showed failure in the rubber and the other 40 % showed failure at the rubber-adhesive interface.

R-25, RC-25, M-50 means that three types of failures are present with R indicating 25 % failure in the rubber, RC, 25 % failure between the rubber and the cement (adhesive) interface, and 50 % failure at the metal-primer interface.

**67. Apparatus**

67.1 *Test Specimens*—Fig. 17 shows a molded test specimen. The diameter of the substrate component (for example, steel, aluminum, plastic, etc.) shall be  $25 \pm 0.1$  mm and the

length  $20 \pm 0.1$  mm. The rubber sections shall be  $23 \pm 0.1$  mm in diameter and  $10 \pm 0.1$  mm in length. A mold to make the bonded specimens may be single cavity or multicavity and may be a mold for compression molding, transfer molding, or injection molding.

67.2 *Test Fixture*—Fig. 18 shows the test fixture for holding the bonded specimens in a strained position. The suggested strain is 100 %, however, some elastomers may have an ultimate shear strain less than 100 % and thus a fixture must be made to accommodate the lower shear strain value. A guideline is as follows:

Ultimate Shear Strain (%)	Test Strain (%)
>200	100
100 to 200	50
50 to 100	25

While the test fixture frames may be steel, acetal plastic is preferred. The plastic does not corrode or otherwise contribute to bond failure. Tests have shown consistent results with acetal frames. The positioning of the hole in the frame’s center piece determines the percent strain.

67.3 *Test Apparatus*—Fig. 19 shows one apparatus that may be used for immersing the fixtured test specimens. While the exposure conditions may be varied to suit individual programs, the following have been used successfully:

Media: 5 % sodium chloride solution in distilled water  
Temperature:  $35 \pm 1^\circ\text{C}$   
Dissolved Oxygen:  $17 \pm 1$  mg/L

**68. Laboratory Preparation of Test Specimens**

68.1 Prepare the test face of the cylinders with any test method for securing adhesion that may be under investigation, for example, phosphate treated, mechanical blast, etc.

68.2 Coat the prepared metal surface with the adhesive system to be tested in accordance with the manufacturer’s recommendations, for example, film thickness, dry time.

68.3 Place the dry adhesive coated specimens in the mold. Fig. 20 illustrates the basic mold design for a transfer mold. For compression or transfer molding, place the rubber preform in the mold cavity or transfer pot. For injection molding, inject the rubber into the mold.

68.4 The test specimens are formed by vulcanizing the desired type of rubber in a mold containing the adhesive coated metal cylinders. The cure conditions (temperature and time) are determined by the elastomer compound being used.

68.5 After a suitable vulcanization cycle, remove the specimens. Store the specimens at a temperature of  $23 \pm 2^\circ\text{C}$  ( $73 \pm 4^\circ\text{F}$ ) for at least 16 h prior to testing.

**69. Procedure**

69.1 Pull one testpiece of each molded batch to determine that 100 % adhesion, for example 100R, is obtained prior to immersion.

69.2 Secure the bonded test specimens in the test fixture with the chosen % strain.

69.3 It is suggested that 5 samples (20 interfaces) are tested for each experiment.

69.4 Immerse these fixtured parts into the test chamber which has been prepared in terms of temperature and salt content. Begin the oxygen bubbling at the selected rate. At various time intervals, remove the fixtured samples, and using

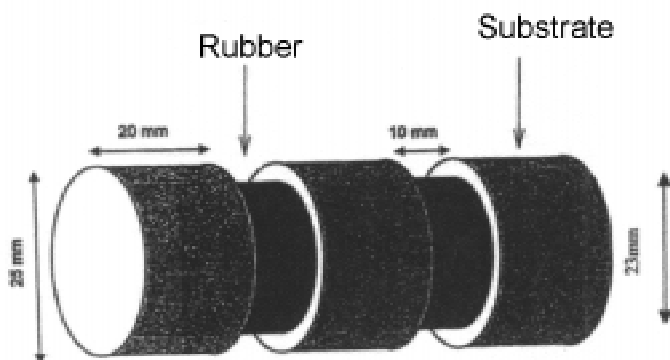

**FIG. 17 Double Shear Test Piece**

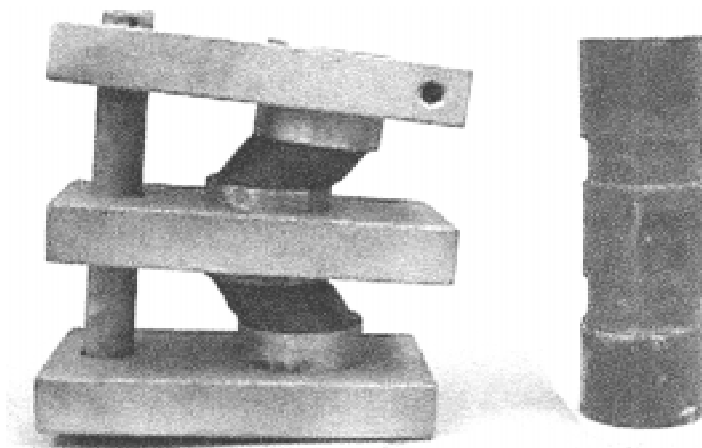

FIG. 18 Test Specimen in a 100 % Strain Fixture (Frame)

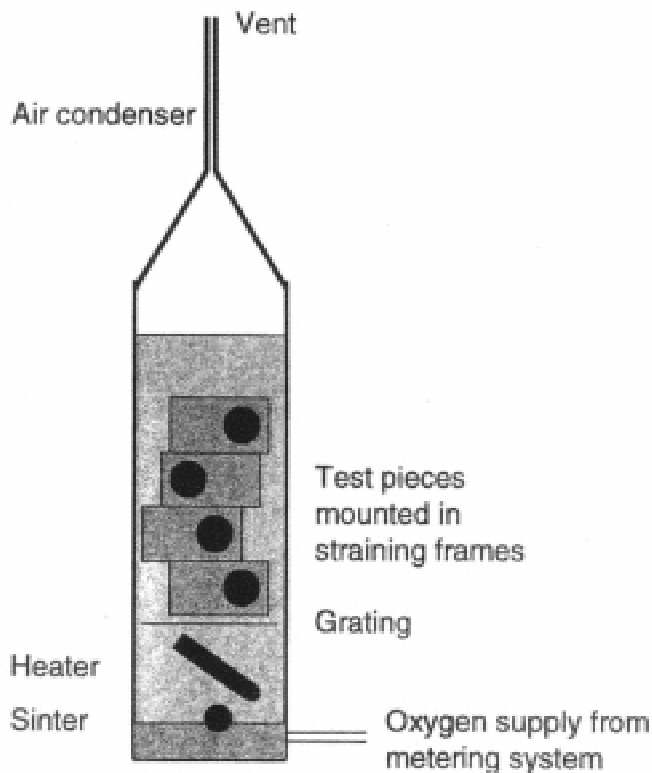

FIG. 19 Test Samples in the Environmental Chamber

a short steel ruler or other calibrated scale, measure the debond depth. Continue the test until the debond depth of 5 mm is noted for each bond.

#### 70. Calculation

70.1 Measure the amount of debond in mm and the corresponding time.

#### 71. Report

71.1 The report shall include the type and code number of the rubber compound,

71.2 Cure time and temperature,

71.3 Molding method (for example, compression, transfer, injection),

71.4 Type of substrate and its surface preparation,

71.5 Test conditions (salt concentration, dissolved oxygen level, temperature, test shear strain),

71.6 The failure criterion (for example, 5 mm of bond failure),

71.7 The average time required by the replicate bonds to meet the failure criterion, along with standard deviation and 95 % confidence interval,

71.8 Molding method used,

**NOTICE: This standard has either been superseded and replaced by a new version or discontinued.  
Contact ASTM International (www.astm.org) for the latest information.**

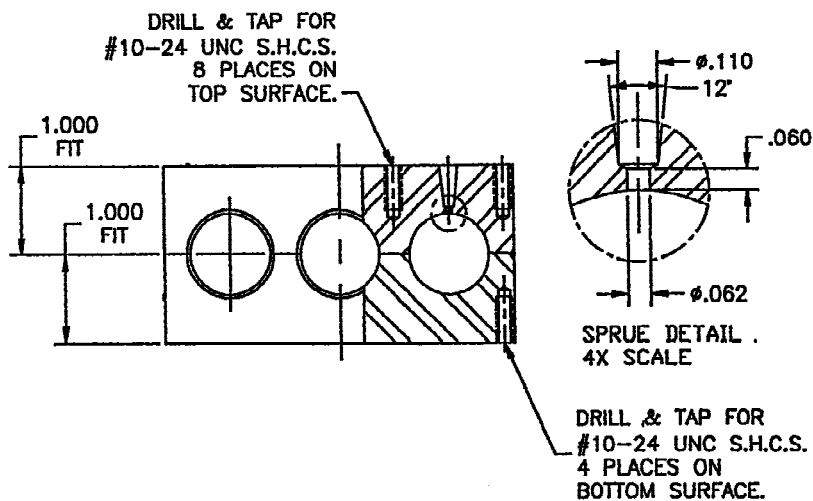
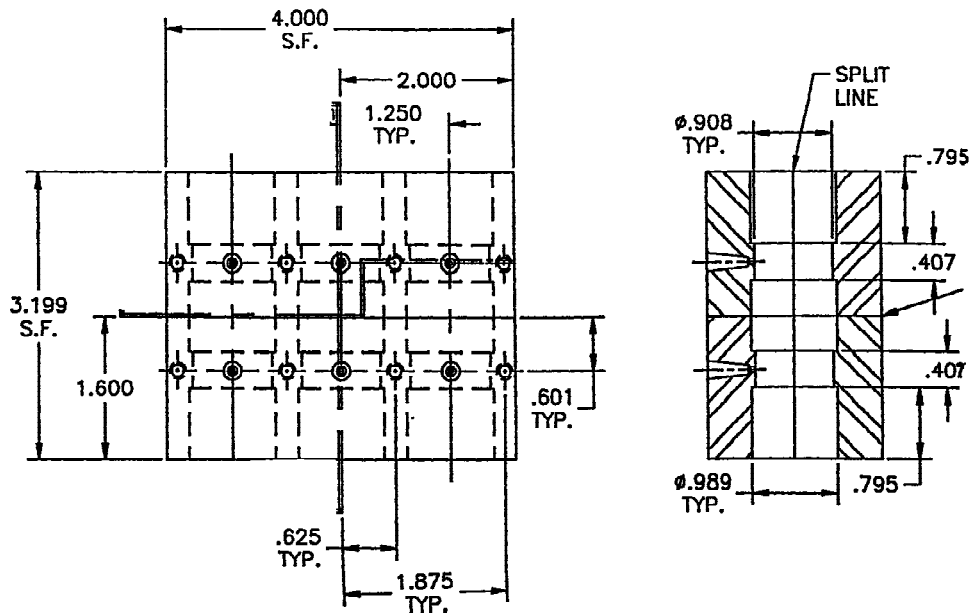

Inches	Millimeters
4.000	101.600
3.199	81.255
2.000	50.800
1.875	47.625
1.600	40.640
1.250	31.750
1.000	25.400
.989	25.121
.908	23.063
.795	20.193
.625	15.875
.601	15.265
.407	10.338
.110	2.794
.062	1.575
.060	1.524

NOTE—All dimensions in mm unless otherwise noted.

FIG. 20 Basic Mold Design for Making Adhesion Test Pieces



71.9 The adhesive used, dilution, application method and film thickness,

71.10 The type and percentage of bond failure, and

71.11 Date of vulcanization and date of failure measurement.

## **72. Precision and Bias**

72.1 Precision and bias do not exist for this test method because resources necessary for round-robin testing have not been forthcoming.

## **73. Keywords**

73.1 adhesion; adhesive; bond durability; double-shear test piece; elastomer; metals; rubber; rubber-to-metal bonding

*ASTM International takes no position respecting the validity of any patent rights asserted in connection with any item mentioned in this standard. Users of this standard are expressly advised that determination of the validity of any such patent rights, and the risk of infringement of such rights, are entirely their own responsibility.*

*This standard is subject to revision at any time by the responsible technical committee and must be reviewed every five years and if not revised, either reapproved or withdrawn. Your comments are invited either for revision of this standard or for additional standards and should be addressed to ASTM International Headquarters. Your comments will receive careful consideration at a meeting of the responsible technical committee, which you may attend. If you feel that your comments have not received a fair hearing you should make your views known to the ASTM Committee on Standards, at the address shown below.*

*This standard is copyrighted by ASTM International, 100 Barr Harbor Drive, PO Box C700, West Conshohocken, PA 19428-2959, United States. Individual reprints (single or multiple copies) of this standard may be obtained by contacting ASTM at the above address or at 610-832-9585 (phone), 610-832-9555 (fax), or service@astm.org (e-mail); or through the ASTM website (www.astm.org).*