



Designation: D 924 – 03a

Standard Test Method for Dissipation Factor (or Power Factor) and Relative Permittivity (Dielectric Constant) of Electrical Insulating Liquids¹

This standard is issued under the fixed designation D 924; the number immediately following the designation indicates the year of original adoption or, in the case of revision, the year of last revision. A number in parentheses indicates the year of last reapproval. A superscript epsilon (ϵ) indicates an editorial change since the last revision or reapproval.

This standard has been approved for use by agencies of the Department of Defense.

1. Scope

1.1 This test method ~~covers~~ describes testing of new electrical insulating liquids as well as liquids in service or subsequent to service in cables, transformers, oil circuit breakers, and other electrical apparatus.

1.2 This test method provides a procedure for making referee tests at a commercial frequency of between 45 and 65 Hz.

1.3 Where it is desired to make routine determinations requiring less accuracy, certain modifications to this test method are permitted as described in Sections ~~19 16 to 27 24~~.

1.4 *This standard does not purport to address all of the safety concerns, if any, associated with its use. It is the responsibility of the user of this standard to establish appropriate safety and health practices and to determine the applicability of regulatory limitations prior to use.* Specific warnings are given in ~~14.4.2, 11.3.3~~.

¹ This test method is under the jurisdiction of ASTM Committee D27 on Electrical Insulating Liquids and Gases and is the direct responsibility of Subcommittee D27.05 on Electrical Tests.

Current edition approved ~~March 10~~, Oct. 1, 2003. Published ~~May~~ December 2003. Originally approved in 1947 as D 924 – 47 T. Last previous edition approved in ~~1999~~ 2003 as ~~D 924 – 99 ϵ 2~~, D 924 – 03.

2. Referenced Documents

2.1 *ASTM Standards:*²

D 150 Test Methods for AC Loss Characteristics and Permittivity (Dielectric Constant) of Solid Electrical Insulating Materials

~~D 923 Test Method~~ 923 Practices for Sampling Electrical Insulating Liquids

D 2864 Terminology Relating to Electrical Insulating Liquids and Gases

D 2865 Practice for Calibration of Standards and Equipment for Electrical Insulating Materials Testing

~~E 145 Specification~~ 691 Practice for Gravity-Convection and Forced-Ventilation Ovens³

~~E 691 Practice for~~ Conducting an Interlaboratory Study to Determine the Precision of a Test Method

2.2 *Other IEEE Standard:*

~~IEC 247-1978 Measurement of Relative Permittivity, Dielectric Dissipation Factor (Tan δ) and DC Resistivity of Insulating Liquids~~⁴

² For referenced ASTM standards, visit the ASTM website, www.astm.org, or contact ASTM Customer Service at service@astm.org. For Annual Book of ASTM Standards, Vol 10.01, Standards volume information, refer to the standard's Document Summary page on the ASTM website.

Annual Book of

³ Available from ~~ASTM Standards, Vol 14.02~~, International. Request RR: D27-1015.

Standard 4 IEEE Standard Techniques for High-Voltage Testing⁴

3. Terminology

3.1 Definitions—Definitions of terms used in this test method are given in Terminology D 2864. Also refer to Test Methods D 150 for detailed discussion of terms.

4. Significance and Use

4.1 *Dissipation Factor (or Power Factor)*—This is a measure of the dielectric losses in an electrical insulating liquid when used in an alternating electric field and of the energy dissipated as heat. A low dissipation factor or power factor indicates low ac dielectric losses. Dissipation factor or power factor may be useful as a means of quality control, and as an indication of changes in quality resulting from contamination and deterioration in service or as a result of handling.

4.1.1 The loss characteristic is commonly measured in terms of dissipation factor (tangent of the loss angle) or of power factor (sine of the loss angle) and may be expressed as a decimal value or as a percentage. For decimal values up to 0.05, dissipation factor and power factor values are equal to each other within about one part in one thousand. In general, since the dissipation factor or power factor of insulating oils in good condition have decimal values below 0.005, the two measurements (terms) may be considered interchangeable.

4.1.2 The exact relationship between dissipation factor (D) and power factor (PF) is given by the following equations:

$$PF = \frac{D}{\sqrt{1 + D^2}} \quad D = \frac{PF}{\sqrt{1 - (PF)^2}} \quad (1)$$

The reported value of D or PF may be expressed as a decimal value or as a percentage. For example:

$$D \text{ or } PF \text{ at } 25^\circ C = 0.002 \text{ or } 0.2\% \quad (2)$$

4.2 *Relative Permittivity (Dielectric Constant)*—Insulating liquids are used in general either to insulate components of an electrical network from each other and from ground, alone or in combination with solid insulating materials, or to function as the dielectric of a capacitor. For the first use, a low value of relative permittivity is often desirable in order to have the capacitance be as small as possible, consistent with acceptable chemical and heat transfer properties. However, an intermediate value of relative permittivity may sometimes be advantageous in achieving a better voltage distribution of a-c electric fields between the liquid and solid insulating materials with which the liquid may be in series. When used as the dielectric in a capacitor, it is desirable to have a higher value of relative permittivity so the physical size of the capacitor may be as small as possible. ~~NOTE 1—See Terminology D 2864 for further definitions.~~

4.3 Theory relating to dielectric measurement techniques and to sources of dielectric loss is given in Test Methods D 150.

5. General Considerations

5.1 Measuring equipment used in these procedures shall be in accordance with Test Methods D 150.

5.2 Theory relating to dielectric measurement techniques and to the sources of dielectric loss is given in Test Methods D 150.

6. Sampling

6.1 Sample electrical insulating liquids in accordance with Test Methods Practices D 923. Samples to be subjected to this test should preferably be obtained through a closed system. If exposed to atmospheric conditions, it is preferable to take the sample when the relative humidity is 50 % or less. If it is not feasible, the length of time the sample is exposed to atmospheric conditions must be kept to a minimum.

6.2 Some liquids, in certain applications, require special handling and processes in the sampling, and these will be found in the governing procedures. Consult such procedures before samples are taken. ~~The relative humidity should be taken at the time of sampling and recorded with the sample identification.~~

6.3 ~~The taken.~~

6.4 The quantity of sample taken for this test shall be sufficient for at least three separate determinations of loss characteristics and relative permittivity.

6.5 The loss characteristic measurement (dissipation factor or power factor) may be affected by contamination introduced during sampling and subsequent handling.

7. Conditioning and Storing Sample

7.1 Store the sample in its original sealed container, shielded from either natural or artificial light. Some liquids, such as oils of petroleum origin, undergo changes when exposed to sunlight. Allow the sealed container to stand undisturbed in the room in which the test is to be made for a sufficient period of time to permit the sample to attain room temperature before it is opened.

Annual Book

⁴ Available from Institute of ASTM Standards, Vol T0.03: Electrical and Electronic Engineers, 445 Hoes Lane, Piscataway, NJ 08854.

8. Storing Test Cell

8.1 When not in use, clean and dry the test cell in accordance with Section 13 and store in a dust-free cabinet until ready for use, at which time clean and dry the cell again in accordance with Section 13.

PROCEDURE FOR MAKING REFEREE TESTS

9. Test Cells

9.1 The design of test cells that conform to the general requirements given in the Annex are considered suitable for use in making these tests.

9.2 Automatic Thermo-Regulator Cell:

9.2.1 When tests are to be made above room temperature but below the flash point, an automatic thermo-regulator cell can be used as long as it provides uniform heating of the test cell.

9.2.2 The automatic thermo-regulator cell must be able to provide rapid, controlled rate of temperature rise, and be able to maintain a liquid temperature constant to within $\pm 1^\circ\text{C}$.

10.

6. Apparatus

6.1 Measuring equipment used in these procedures shall be in accordance with Test Methods D 150.†

6.2 Use only a three-terminal cell for these tests.

6.3 The design of test cells that conform to the general requirements given in the Annex are considered suitable for use in making these tests.

6.4 Forced-Draft Oven:

†6.4.1 When the tests are to be made above room temperature, a suitable forced-draft, thermostatically controlled oven shall be used as the test chamber. The oven must be capable of meeting the temperature requirements set out in Section 14. 11. For tests at room temperature the unheated oven can be conveniently used as the test chamber.

†6.4.2 Provide the test chamber with an opening in the wall through which two lengths of TFE-fluorocarbon-insulated (or similar) shielded cable pass to make electrical connection from the measuring equipment and high-voltage transformer, respectively, to the test cell. Use a perforated ceramic plate or disk to insulate the test cell from the metal flooring of the oven if the flooring is not insulated from the oven. Provide a safety interlock on the door of the oven so that the electrical circuit supplying voltage to the test cell will be broken when the oven door is opened.

†6.4.3 A

6.4.3 A cross-sectional view of the test chamber with a three-electrode test cell in place and with test cables connected is shown in Fig. 1.

6.5 Automatic Thermo-Regulator Cell:

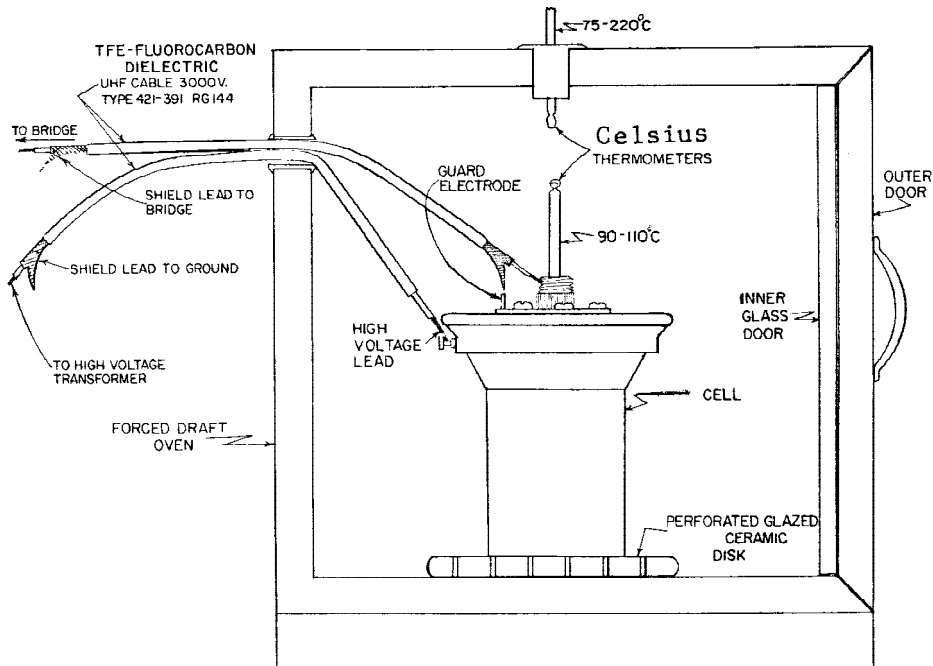

FIG. 1 Test Set-Up for Dissipation Factor Measurements at Elevated Temperatures Using Three-Electrode Test Cell

6.5.1 When tests are to be made above room temperature but below the flash point, an automatic thermo-regulator cell can be used as long as it provides uniform heating of the test cell.

6.5.2 The automatic thermo-regulator cell must be able to provide rapid, controlled rate of temperature rise, and be able to maintain a liquid temperature constant to within $\pm 1^\circ\text{C}$.

7. Calibration

7.1 Calibration of test instruments shall be traceable to national standards.

7.2 Verify the calibration at least annually using reference devices that are traceable to national standards.

7.3 Refer to Practice D 2865 and IEEE Standard 4 for guidelines on calibrating test equipment.

8. Test Temperature

~~12.1~~ 8.1 The temperature at which a referee test is made shall be mutually agreed upon between the purchaser and the seller. Measurements are made at many different temperatures. For acceptance tests, it is generally made at a temperature of 100°C , while for routine testing it is usually made at room temperature, 25, 85 or 100°C . In some research investigations, tests may be made at considerably higher temperatures while in other cases, particularly for tests on cable oils in service, tests may be made over a range of temperatures.

~~12.~~

9. Test Voltage

~~12.1~~ 9.1 The average stress to which the specimen is subjected shall not be less than 200 V/mm (5 V/mil) (rms). Tests at higher stresses are desirable but shall not reach such values that electrical discharges across the cell insulating surfaces occur or that internal ionization of the specimen may be expected. Stress ranges in normal usage for referee tests are 200 to 1200 V/mm (5 to 30 V/mil) (rms).

~~12.2~~ 9.2 Because the ac loss characteristics can vary with voltage stress, for reference purposes it is desirable to make the measurements at a specific value of voltage stress within the limits in ~~12.9.1~~ 9.1.

~~12.3~~ 9.3 Referee tests should be carried out in the frequency range 45–65 Hz.

130. Cleaning Test Cell

130.1 The cleanliness of the test cell is of paramount importance when measuring loss characteristics because of the inherent susceptibility of most insulating liquids to contaminating influences of the most minute nature. For this reason, clean and dry the cell immediately prior to making the test, and strictly observe the procedures and precautions outlined in 130.2 to 130.5.

130.2 Dismantle the cell completely and wash all the component parts thoroughly with a technical grade of a suitable solvent (such as acetone, pentane, petroleum ether, or heptane). Wash the component parts with a mild abrasive soap or detergent. Take care not to lay the electrodes on any surface. Rinse all parts thoroughly with hot tap water, then with cold tap water, followed by several ~~rinsings~~ rinses with distilled water. Take extreme care during the washing and rinsing of some test cells to prevent any moisture from entering the thermometer well in the inner electrode. As a precaution against this eventuality, use a suitable stopper to plug this opening prior to starting the cleaning operation.

130.3 After the surfaces of the measuring, guard, and high voltage electrodes have been washed, do not touch these surfaces during the rinsing or any subsequent operation.

130.4 Place the component parts of the test cell in an oven maintained at 110°C for a period of not less than 60 min. Do not dry test cells made of Monel at this elevated temperature for more than 90 min as oxidation will take place causing erroneous results. Take care that the surfaces on which the component parts of the cell are placed in the oven are clean.

130.5 At the expiration of the drying period, assemble the cell ~~in the oven~~, using clean cotton gloves as protection for the hands and ~~observing the precaution given in 13.3~~.

~~13.6~~ If using a forced-draft oven, quickly transfer the assembled test cell to the test chamber maintained at a temperature of above the desired test temperature prevent contamination from skin oils and allow the cell to attain temperature equilibrium. The exact temperature will depend on both the oven and cell design. The test chamber shall be such that when the test specimen, preheated to 2°C below the test temperature, is transferred to the cell, the test temperature is attained and maintained within 20 min. If using an automatic thermo-regulator cell, follow 14.5.

~~14.~~ salt.

11. Preparation of Specimen and Filling Test Cell

14.1.1 ~~Store the sample in its original sealed container, shielded from light. Some liquids, such as oils of petroleum origin, undergo changes when exposed to sunlight. Allow the sealed container to stand undisturbed in the room in which the test is to be made for a sufficient period of time to permit the sample to attain room temperature before it is opened.~~

14.1.2 When insulating liquids are heated to elevated temperatures, some of their characteristics undergo a change with time and the change, even though of the minutest nature, may be reflected in the loss measurement. It is therefore desirable that the elapsed

time necessary for the test specimen to attain temperature equilibrium with the test cell be held to a minimum. For optimum procedure do not exceed 20 min for this time. It is essential, therefore, that the procedures outlined in 14.3, 14.4.1 through 14.4.3, or 14.5.1 through 14.5.4 below be closely followed.

14.3 *Forced-Draft Oven:*

11.3.1 In order that representative test specimens may be obtained, gently tilt or invert the sample container and swirl the liquid several times. Immediately after mixing the sample, pour a quantity of liquid sufficient for four fillings of the test cell into a chemically clean, dry beaker and heat on a hot plate to a temperature 2°C below the desired test temperature. ~~During~~ Stir the heating period, stir the fluid frequently.

~~14.4~~ *Forced-Draft Oven:*

~~14.4.1~~ Remove frequently during heating.

11.3.2 Remove the cell from the test chamber, lift out the inner electrode, but do not rest it on any surface, and fill the cell with a portion of the heated ~~sample~~. specimen. Replace the beaker with the remainder of the heated sample on the hot plate. Insert the inner electrode and rinse the electrodes by twice raising and lowering the inner electrode. Remove the inner electrode and hold it suspended in air; then decant the rinsing liquid and immediately fill the cell from the remainder of the heated ~~sample~~. specimen. Replace the inner electrode.

~~14.4.3.23~~ Insert a mercury thermometer graduated in 0.25°C increments, or other temperature measuring devices (for example, thermocouples) that provide equal accuracy, in the thermometer well provided in the inner electrode (**Warning**—A spring-loaded thermocouple may be used for measuring the temperature of the inner electrode, but extreme caution shall be exercised that these wires do not come in contact with the high-voltage lead and do not pick up stray emfs.), ~~graduated in 0.25°C increments, or other temperature measuring devices (for example, thermocouples) that provide equal accuracy, in the thermometer well provided in the inner electrode.~~ emfs). Immediately return the filled cell to the test chamber (adjusted to a temperature above the desired test temperature) and make the necessary electrical connections to the cell.

~~14.4.3.4~~ Perform the operations described in ~~14.4.1~~ 11.3.2 and ~~14.4.2~~ 11.3.3 as rapidly as possible. **NOTE 2**—The above technique, after much experimenting, has been evolved to give the most repeatable results for tests at 100°C. Little experience has been obtained from tests at higher temperatures. However, individual laboratories engaged in work at temperatures above 100°C have probably developed their own technique.

~~14.5~~

11.4 *Automatic Thermo-Regulator Cell:*

14.1.54.1 Gently swirl or invert the sample container to obtain a representative test specimen.

14.1.54.2 Fill the test cell and flush to rinse thoroughly both the inner and outer electrodes with a portion of the sample. Decant the rinsing liquid and immediately fill the cell with a new aliquot of sample.

~~14.1.54.3~~ Replace inner electrode and make all necessary electrical connections to the cell.

~~14.5.4~~ Set cell. On some instruments the cell must be in place before filling with specimen.

11.4.4 Set the automatic thermo-regulator for the test temperature and initiate heating. Record data as soon as the test temperature is reached.

152. Procedure—Loss Characteristics

152.1 Make the measurements while the temperature of the inner electrode is within ±0.5°C of the desired test temperature.

152.2 On completing the initial measurement, ~~remove the inner electrode~~, pour off the liquid, and refill the cell, following the same procedure and exercising the same precautions used in making the first filling, and take another measurement. If the difference in the measurements of the two test specimens is equal to or less than 0.0001, plus 10 % of the higher of the two values, no further tests are required, and the reported value for the sample shall be taken as the average of the two measurements. If the difference in the measurements of the two test specimens is greater than 0.0001, plus 10 % of the higher of the two values, refill the cell and take a third measurement. If the difference between the third measurement and either the first or second is not within 0.0001, plus 10 % of the higher of the two values used in this computation, discard these results, reclean the cell, obtain another sample, and repeat the procedure until two measurements from a sample are obtained that do meet the prescribed limits.

163. Procedure—Relative Permittivity

163.1 Measure the capacitance of the test cell with air as the dielectric and then with the cell filled with the liquid. Use these measurements in calculating the relative permittivity from the following ~~equation (Note 3):~~ equation:

$$K' = C_x/C_v \quad (3)$$

where:

- K' = relative permittivity of the liquid,
- C_x = capacitance of test cell with the liquid as the dielectric, and
- C_v = capacitance of test cell with air as the dielectric.

NOTE 3—Refer to Sections 3 and 7 of Test Methods D 150.

17-

14. Report

174.1 Report the following information:

174.1.1 Sample identification,

174.1.2 Type of test cell used,

174.1.3 Measurement procedure: referee,

174.1.4 Average voltage gradient in the sample while under test, in volts per millimeter (volts per mil) (rms),

174.1.5 Frequency of applied voltage,

174.1.6 Temperature of the sample while under test,

174.1.7 Temperature and humidity of the room during test,

174.1.8 Dissipation factor or power factor of the sample, usually expressed as a percentage (%), and

174.1.9 Relative permittivity (dielectric constant) of the sample, when required.

185. Precision and Bias

185.1 *Interlaboratory Test Program* —An interlaboratory study of power dissipation factor in mineral insulating oil was conducted in accordance with Practice E 691 in ~~eight~~ twelve laboratories with four different oils. Each sample was tested using the referee procedure at 25°C and at 100°C. The results are documented in a research report available from ASTM International Headquarters.

~~18.2-5~~
15.2 *Precision*—The precision information given below for referee testing of power dissipation factor is for the comparison of two test results, each of which is the average of two test determinations.

185.2.1 *95 % Repeatability Limit (within laboratory)* —The absolute difference between two results obtained in the same laboratory by the same analyst may be expected to be below these calculated values 95 % of the time:

$$r_{25C} = 0.05 X^{0.68} \% \quad (4)$$

$$r_{25C} = 0.06 X^{0.65} \% \quad (4)$$

$$r_{100C} = 0.163 (X + 0.136) \% \quad (5)$$

$$r_{100C} = 0.237 X^{0.609} \% \quad (5)$$

where X is the average of the two results being compared.

185.2.2 *95 % Reproducibility Limit (between laboratories)* —The absolute difference between two results obtained in different laboratories by different analysts may be expected to be below these calculated values 95 % of the time:

$$R_{25C} = 0.465 X^{0.68} \% \quad (6)$$

$$R_{25C} = 0.384 X^{0.65} \% \quad (6)$$

$$R_{100C} = 0.812 (X + 0.136) \% \quad (7)$$

$$R_{100C} = 0.467 X^{0.609} \% \quad (7)$$

where X is the average of the two results being compared.

15.2.3 Calculated values of repeatability and reproducibility are shown in the table below:

<u>%DF@25C</u>	<u>r</u>	<u>R</u>	<u>%DF@100C</u>	<u>r</u>	<u>R</u>
0.005	0.002	0.012	0.1	0.058	0.115
0.05	0.009	0.055	0.5	0.155	0.306
0.1	0.013	0.086	1.0	0.237	0.467
0.3	0.027	0.176	4.0	0.551	1.086

15.3 *Bias*:

185.3.1 As thisere is no accepted reference material available for dissipation factor (or power factor), no bias statement can be made.

185.3.2 As there is no accepted reference available for relative permittivity, no bias statement can be made.

PERMISSIBLE MODIFICATIONS WHEN MAKING ROUTINE TESTS

196. General

196.1 The following sections outline certain modifications to the Procedure for Making Referee Tests, permissible (1) when it is desirable to get an approximation of the dissipation factor or power factor of a sample, or (2) when testing a group of samples of the *same* type of insulating liquid to determine if the dissipation factor or power factor is greater or less than some specified value.

20.—

17. Test Cell

2017.1 Any test cell conforming to the requirements given in the Annex may be used. For routine tests, however, the requirement for a guard electrode may be waived, provided that the two-electrode cell used is of adequate capacitance and with sufficient ratio of surface area to sample thickness, in order to provide proper operation of the measuring equipment.

218. Test Chamber

218.1 An oil bath having uniform temperature distribution and provided with adequate temperature regulation may be used for routine tests, provided that when the test cell is immersed in the bath, the temperature difference in the test cell between any part of the inner electrode and the outer electrode does not exceed 2°C. A less satisfactory method is use of a hot plate, but variations in temperature throughout the cell may lead to questionable results. In general, the use of a forced-draft air test chamber or automatic thermo-regulator cell is preferable.

22.—

19. Test Temperature

2219.1 The loss characteristic measurement may be made when the test specimen is within $\pm 2.0^\circ\text{C}$ of the desired temperature.

230. Test Voltage

230.1 In order that low-voltage instrumentation may be used for making the routine tests, no minimum voltage stress is specified. However, the precaution on high electrical stresses given in Section ~~12~~ 9 shall be observed.

230.2 Frequencies from 25 to 1000 Hz may be used for routine tests.

NOTE 41—The dissipation factor of an electrical insulating liquid usually decreases with increasing frequency in the frequency range covered by 230.2. An explanation for this behavior is given in Appendix X3 of Test Methods D 150. The manner in which dissipation factor varies with frequency is determined by the nature of the dielectric losses, that is, whether they are predominantly polar or ionic, or are a combination of both types. Accordingly, there is no simple conversion factor for determining the dissipation factor at 60 Hz, for example, if the measurements are made at either a higher or lower frequency.

241. Cleaning Test Cell

241.1 Since some two-electrode cells cannot be dismantled, the cleaning procedure given in ~~Section 13~~ 10 cannot always be followed. Where this applies, it is imperative that each laboratory evolves a good cleaning procedure for the cell used so that repeatable results can be obtained. Solvents mentioned in 130.2 as being satisfactory may be used as cleaning agents.

241.2 When a number of samples of the *same* type of fluid are to be tested consecutively, the same test cell may be used without cleaning it, provided the measured value of power factor or dissipation factor of the sample previously tested was less than the specified value. If the measured value of the last sample tested was greater than the specified value, the test cell shall be cleaned before being used for further tests.

252. Preparation of Specimen and Filling Test Cell

252.1 Because of the difference in construction of the various types of test cells that may be used for routine tests, no detailed procedure for preparation of the specimen and filling of the test cell is given. Due regard should be given to the precautions outlined in Section 141.

252.2 Always rinse the test cell with a portion of the sample to be tested before the cell is filled.

263. Electrical Connection

263.1 When making electrical connection to a two-electrode cell, securely clip the shield on the lead usually connected to the guard electrode (see Fig. 1) to the TFE-fluorocarbon insulation in order to prevent contact with any surface.

263.2 Always connect the high-voltage lead to the outer electrode as shown in Fig. 1.

274. Number of Tests

274.1 Only a single test specimen need be tested in measuring dissipation factor or power factor.

285. Report

285.1 Report the following information:

285.1.1 Sample identification,

285.1.2 Type of test cell used,

285.1.3 Measurement procedure: routine,

285.1.4 Average voltage gradient in the test specimen sample, while under test, in volts per millimetre (volts per mil) (rms),

285.1.5 Frequency of applied voltage,

- 285.1.6 Temperature of the sample while under the test,
- 285.1.7 Temperature and humidity of the room during test, and
- 285.1.8 Dissipation factor or power factor of the sample, usually expressed as a percentage (%).

296. Precision and Bias

296.1 Precision:

296.1.1 The precision of this test method for making routine tests has not been determined through an interlaboratory test program. Refer to 185.2 for precision regarding referee testing.

296.1.2 A single operator statement was developed from ten results on one material from a single laboratory.

296.1.2.1 The single operator coefficient of variation for power factor by the routine method at 25°C has been found to be 3.8 %; therefore, results of two properly conducted tests by the same operator on the same sample using the same equipment should not differ from each other by more than 11 % of their average.

296.1.2.2 The single operator coefficient of variation for power factor by the routine method at 100°C has been found to be 3.1 %; therefore, results of two properly conducted tests by the same operator on the same sample using the same equipment should not differ from each other by more than 9 % of their average.

296.2 *Bias*—As there is no accepted reference material available for dissipation factor (or power factor), no bias statement can be made.

~~30.~~

27. Keywords

3027.1 dielectric constant; dissipation factor; power factor; relative humidity

ANNEX

(Mandatory Information)

A1. CELLS USED FOR MEASURING DISSIPATION FACTOR (OR POWER FACTOR) AND RELATIVE PERMITTIVITY (DIELECTRIC CONSTANT) OF ELECTRICAL INSULATING LIQUIDS

A1.1 *Design of Cell*—A cell for the purpose of measuring the loss characteristic and relative permittivity (dielectric constant) of electrical insulating liquids shall meet the following general requirements:

A1.1.1 The design of the cell shall be such as to facilitate easy and thorough cleaning of its component parts, permit the use of the cell in a suitable temperature bath, and provide means for measuring the temperature of the liquid under test.

A1.1.2 The materials used in constructing the cell shall be nonporous and capable of satisfactorily withstanding the temperature to which the cell will be subjected under test. The alignment of the electrodes shall not be influenced by this temperature nor by the operation of filling the cell with the test liquid.

A1.1.3 The electrodes or their surfaces shall be made of a metal capable of resisting attack by mild acids such as are found in oils of petroleum origin, particularly after prolonged exposure at elevated temperatures. Metals that have been found satisfactory from this standpoint are gold, nickel, Monel, platinum, and stainless steel. In general, plated surfaces have been found less satisfactory than solid metal electrodes when testing liquids having low loss. Plated surfaces that may be satisfactory for testing liquids having low acidity and for short periods of time are gold, platinum, nickel, chromium over nickel, or rhodium.

A1.1.4 In order to achieve a high order accuracy in determining the dissipation factor (or power factor) or dielectric constant, a guard electrode shall be provided which adequately shields the measuring electrode. Use a shielded wire or coaxial cable for connecting the guard and measuring electrodes to the bridge.

A1.1.5 The solid insulation used to support the guard electrode relative to the measuring electrode shall not extend into the portion of the sample being tested.

A1.1.6 The insulating materials used in constructing the cell shall not absorb or be adversely affected by the test liquids or cleaning solvents. The dissipation factor of these insulating materials must necessarily be low, particularly that between the guard and measuring electrodes; otherwise difficulty may be experienced in balancing the guard circuits at elevated temperatures. Insulating materials that have proven satisfactory are boron nitride, borosilicate glass, quartz, steatite, and TFE-fluorocarbon. Thermoplastic materials such as hard rubber and polystyrene, although having good electrical properties, are not suitable as they soften below 130°C. Insulating materials of the molded mica-dust type, have been found to absorb solvents and therefore are not considered as satisfactory in the measurement of low loss liquids.

A1.1.7 In designing the cell, the distance across the surface of the test specimen and across the solid insulating material between the guard and the measuring electrode shall be great enough adequately to withstand the test potential used. Leakage across these paths has been found to produce an unsteady bridge balance on some bridges.

A1.1.8 Fig. A1.1 The surface area of the measuring electrode and the gap spacing between the measuring electrode and high-voltage electrode shall be such that the ratio of surface area to thickness of the test sample shall be large enough to provide sufficient current for adequate operation of the measuring equipment. No minimum capacitance is therefore suggested. It is required, however, that the precision of the measurements meets the intended accuracy of this test method.

A1.2 Fig. A1.1—The cell shown in Fig. A1.1 is a two-terminal cell intended solely for making routine tests. The concentric cylinders are of nickel-plated brass which are mounted on a TFE-fluorocarbon base and contained in an 800-mL borosilicate glass beaker. The volume of oil required when using this cell is 500 mL. The cell is suitable for use at voltages up to 5 kV and temperatures up to 150°C.

ASTM International takes no position respecting the validity of any patent rights asserted in connection with any item mentioned in this standard. Users of this standard are expressly advised that determination of the validity of any such patent rights, and the risk of infringement of such rights, are entirely their own responsibility.

This standard is subject to revision at any time by the responsible technical committee and must be reviewed every five years and if not revised, either reapproved or withdrawn. Your comments are invited either for revision of this standard or for additional standards and should be addressed to ASTM International Headquarters. Your comments will receive careful consideration at a meeting of the responsible technical committee, which you may attend. If you feel that your comments have not received a fair hearing you should make your views known to the ASTM Committee on Standards, at the address shown below.

This standard is copyrighted by ASTM International, 100 Barr Harbor Drive, PO Box C700, West Conshohocken, PA 19428-2959, United States. Individual reprints (single or multiple copies) of this standard may be obtained by contacting ASTM at the above address or at 610-832-9585 (phone), 610-832-9555 (fax), or service@astm.org (e-mail); or through the ASTM website (www.astm.org).

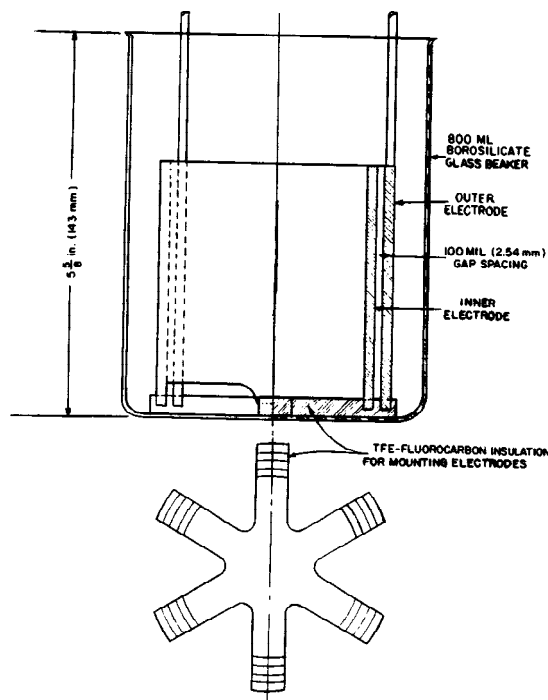

FIG. A1.1 Two-Terminal Cell for Routine Tests