



Standard Test Method for Acoustic Emission Testing of Insulated Aerial Personnel Devices with Supplemental Load Handling Attachments¹

This standard is issued under the fixed designation F 1430; the number immediately following the designation indicates the year of original adoption or, in the case of revision, the year of last revision. A number in parentheses indicates the year of last reapproval. A superscript epsilon (ϵ) indicates an editorial change since the last revision or reapproval.

1. Scope

1.1 This test method describes a procedure for acoustic emission (AE) testing of insulated aerial personnel devices (IAPDs) with supplemental load handling attachments.

1.1.1 *Equipment Covered*—This test method covers the following types of vehicle-mounted insulated aerial personnel devices with supplemental load handling attachments:

- 1.1.1.1 Extensible-boom IAPDs,
- 1.1.1.2 Articulating-boom IAPDs, and
- 1.1.1.3 Any combination of 1.1.1.1 and 1.1.1.2.

1.1.2 *Equipment Not Covered*—This test method does not cover any of the following equipment:

- 1.1.2.1 Noninsulated aerial devices,
- 1.1.2.2 Insulated aerial personnel devices without supplemental load handling attachments,
- 1.1.2.3 Digger-derricks with platform,
- 1.1.2.4 Cranes with platform, and
- 1.1.2.5 Aerial devices with load-lifting capabilities located anywhere other than adjacent to the platform.

1.2 The AE test method is used to detect and area-locate emission sources. Verification of emission sources may require the use of other nondestructive test (NDT) methods, such as radiography, ultrasonics, magnetic particle, liquid penetrant, and visual inspection.

NOTE 1—Warning: This test method requires that external loads be applied to the superstructure of the vehicle under test. During the test, caution must be taken to safeguard personnel and equipment against unexpected failure or instability of the vehicle or components.

1.3 *This standard does not purport to address all of the safety problems, if any, associated with its use. It is the responsibility of the user of this standard to establish appropriate safety and health practices and determine the applicability of regulatory limitations prior to use.*

2. Referenced Documents

2.1 ASTM Standards:

E 569 Practice for Acoustic Emission Monitoring of Structures

During Controlled Stimulation²

E 650 Guide for Mounting Piezoelectric Acoustic Emission Sensors²

E 750 Practice for Characterizing Acoustic Emission Instrumentation²

E 976 Guide for Determining the Reproducibility of Acoustic Emission Sensor Response²

E 1067 Practice for Acoustic Emission Testing of Fiberglass Reinforced Plastic Resin (FRP) Tanks/Vessels²

E 1316 Terminology for Nondestructive Examinations²

F 914 Test Method for Acoustic Emission for Insulated Aerial Personnel Devices³

2.2 Other Standards:

ANSI A92.2 Standard for Vehicle-Mounted Elevating and Rotating Aerial Devices⁴

ASNT SNT-TC-1A Recommended Practice for Personnel Qualification and Certification in Nondestructive Testing⁵

Equipment Manufacturer's Institute,⁶ Manufacturers of Aerial Devices and Digger-Derricks Council (EMI/MADDDC), Nomenclature and Specifications for Truck-Mounted:

- (a) Extensible Aerial Devices,
- (b) Articulating Aerial Devices, and
- (c) Digger-Derricks

3. Terminology

3.1 Definitions:

3.1.1 *acoustic emission (AE)*—the class of phenomena whereby elastic waves are generated by the rapid release of energy from a localized source or sources within a material, or the transient elastic wave(s) so generated. Acoustic emission is the recommended term for general use. Other terms that have been used in AE literature include (1) stress wave emission, (2) microseismic activity, and (3) emission or acoustic emission with other qualifying modifiers.

3.1.2 *amplitude (acoustic emission signal amplitude)*—the peak voltage of the largest excursion attained by the signal

² Annual Book of ASTM Standards, Vol 03.03.

³ Annual Book of ASTM Standards, Vol 10.03.

⁴ Available from the American National Standards Institute, 11 West 42nd Street, 13th Floor, New York, NY 10036.

⁵ Available from American Society of Nondestructive Testing, 4153 Arlingate Plaza, Caller #28518, Columbus, OH 43228.

⁶ Available from the Equipment Manufacturer's Institute, 410 N. Michigan Ave., Chicago, IL 60611.

¹ This test method is under the jurisdiction of ASTM Committee F-18 on Electrical Protective Equipment for Workers and is the direct responsibility of Subcommittee F18.55 on Acoustic Emission.

Current edition approved Nov. 10, 1998. Published February 1999. Originally published as F 1430-92. Last previous edition F 1430-92.

waveform from an emission event.

3.1.3 *amplitude distribution*—a display of the number of acoustic emission events with signals that exceed an arbitrary amplitude as a function of amplitude.

3.1.4 *articulating-boom aerial device*—an aerial device with two or more hinged boom sections.

3.1.5 *attenuation*—the loss of energy per unit distance, typically measured as loss of signal peak amplitude with unit distance from the source of emission.

3.1.6 *channel*—an input to the main AE instrument that accepts a preamplifier output.

3.1.7 *commoned*—two or more sensors interconnected such that the sensor outputs are electronically processed by a single channel without differentiation of sensor origin.

3.1.8 *count* also *acoustic emission count*, n —the number of times the acoustic emission signal amplitude exceeds a preset threshold during any selected portion of a test.

3.1.9 *decibel (dB)*—the logarithmic expression of a ratio of two single peak amplitudes. A reference scale expresses the logarithmic ratio of a single peak amplitude to a fixed reference amplitude.

$$\text{Signal peak amplitude (dB)} = 20 \log_{10} (A_1/A_0)$$

where:

A_0 = 1 μ V at the sensor output (before amplification), and
 A_1 = peak voltage of the measured acoustic emission signal.

dB Value	Acoustic Emission Reference Scale	
	Voltage At Sensor Output	Voltage At Integral Preamp Sensor Output (40-dB Gain)
0	1 μ V	100 μ V
20	10 μ V	1 mV
40	100 μ V	10 mV
60	1 mV	100 mV
80	10 mV	1 V
100	100 mV	10 V

3.1.10 *insulated aerial personnel device (IAPD)*—any device (extensible or articulating) which is designed primarily to position personnel and may be equipped with a supplemental load handling attachment.

3.1.11 *event (acoustic emission event)*—a local material change giving rise to acoustic emission.

3.1.12 *event count (N_c)*—the number obtained by counting each discerned acoustic emission event once.

3.1.13 *extensible-boom aerial device*—an aerial device, except the aerial ladder type, with a telescopic or extensible boom.

3.1.14 *first-hit*—a mode of operation of AE monitoring equipment in which an event occurring on one channel will prevent all other channels from processing data for a specified period of time. The channel with a sensor closest to the physical location of the emission source will then be the only channel processing data from that source.

3.1.15 *insulated aerial device*—an aerial device designed with dielectric components to meet a specific electrical insulation rating.

3.1.16 *insulator*—any part of an aerial device such as, but not limited to, the upper boom, lower boom or supporting structure, made of a material having a high dielectric strength,

usually FRP or the equivalent.

3.1.17 *noise*—any undesired signal that tends to interfere with the normal reception or processing of the desired signal.

3.1.18 *non-overcenter*—the feature of an aerial device is such that the upper boom cannot travel past vertical orientation with respect to the ground.

3.1.19 *overcenter*—the feature of an aerial device is such that the upper boom travels past vertical orientation with respect to the ground.

3.1.20 *qualified personnel*—personnel who, by possession of a recognized degree, certificate, professional standing, or skill, and who, by knowledge, training, and experience, have demonstrated the ability to deal with problems relating to the subject matter, the work, or the project.

3.1.21 *rated load capacity (RLC)*—the maximum allowable load as stated by the aerial device manufacturer which by combination of the platform load and supplemental load, may be placed on the aerial device at a designated boom position and a designated SLHA orientation.

3.1.22 *signal (emission signal)*—a signal obtained by detection of one or more acoustic emission events.

3.1.23 *supplemental load*—a load which may be affixed to a supplemental load-handling attachment on an insulated aerial personnel device.

3.1.24 *supplemental load attachment capacity (SLAC)*—the maximum allowable load, as stated by the aerial device manufacturer, which may be affixed to the supplemental load-handling attachment at specified positions of the attachments.

3.1.25 For definitions of other terms in this test method, refer to Terminology E 1316 and EMI/MADDDC.

3.2 *Definitions of Terms Specific to This Standard:* (see Fig. 1 and Fig. 2):

3.2.1 *elbow*—the structure connecting the upper boom to the lower boom, about which one boom articulates relative to the other.

3.2.2 *elbow pin*—the horizontal pin about which the upper boom rotates relative to the lower boom.

3.2.3 *lift cylinder*—the hydraulic cylinder that lifts the lower boom and the extensible boom(s).

3.2.4 *lower boom*—the structural member, attached to a turntable or base, that supports the upper boom.

3.2.5 *lower-boom cylinder*—the hydraulic cylinder that articulates the lower boom.

3.2.6 *lower-boom insulator*—the part of the lower boom made of high-dielectric strength material (usually fiberglass reinforced plastic or equivalent).

3.2.7 *lower-boom pin*—the horizontal pin about which the lower boom is raised and lowered relative to the turntable.

3.2.8 *outriggers*—the structural members that, when properly extended or deployed on firm ground, assist in stabilizing the vehicle on which the aerial device is mounted.

3.2.9 *pedestal*—the stationary base of the aerial device that supports the turntable.

3.2.10 *platform*—the personnel-carrying component of an aerial device, such as a bucket, basket, stand, or equivalent.

3.2.11 *platform pin*—the horizontal pin about which the platform rotates relative to the upper boom.

F 1430

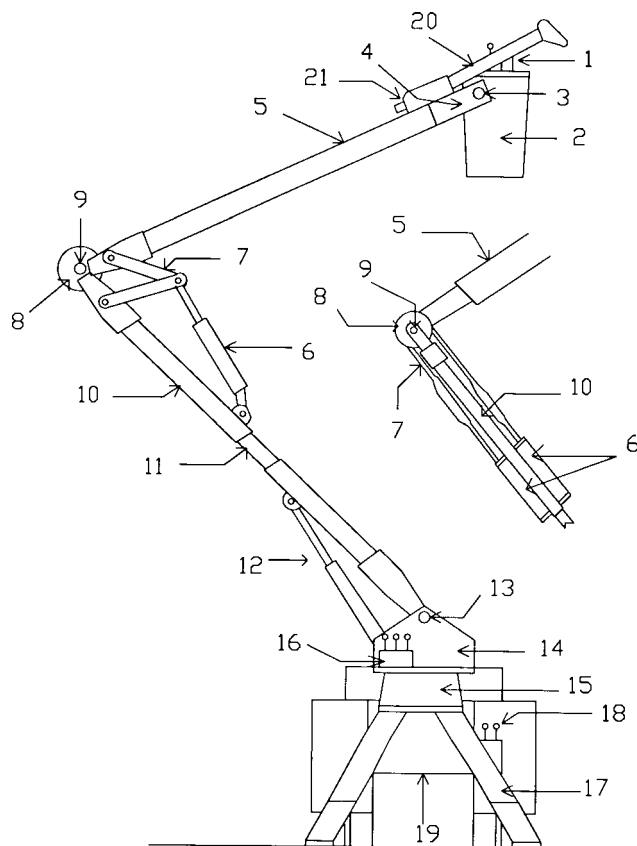

- | | | |
|-------------------------------|--------------------------|---|
| 1. Upper Controls | 8. Elbow | 15. Pedestal |
| 2. Platform | 9. Elbow Pin | 16. Lower Controls |
| 3. Platform Pin | 10. Lower Boom | 17. Outriggers |
| 4. Upper Boom Tip | 11. Lower Boom Insulator | 18. Outrigger Controls |
| 5. Upper Boom | 12. Lower Boom Cylinder | 19. Stabilizers |
| 6. Upper Boom Cylinder | 13. Lower Boom Pin | 20. Supplemental Load Handling Attachment Arm |
| 7. Upper Boom Drive Mechanism | 14. Turntable | 21. Supplemental Load Handling Attachment Bracket |

FIG. 1 Articulating-Boom IAPD Nomenclature Diagram

3.2.12 *rated platform capacity (RPC)*—the maximum load as stated by the manufacturer for which an aerial device is designed to operate, consisting of the combined weight of the personnel and all items carried on or in the platform.

3.2.13 *stabilizers*—a means to assist in stabilizing the vehicle, such as outriggers, torsion bars, and spring lockouts.

3.2.14 *supplemental load-handling attachment (SLHA)*—a device(s) affixed to the upper-boom tip area which is designed to lift and or position materials.

3.2.15 *supplemental load-handling attachment bracket*—the apparatus which affixes the supplemental load handling attachment to the IAPD.

3.2.16 *turntable*—the rotating base of the aerial device that supports the boom(s).

3.2.17 *upper boom*—the structural member, attached to the lower boom, that supports the platform.

3.2.18 *upper-boom cylinder*—the hydraulic cylinder that articulates the upper boom.

3.2.19 *upper-boom drive mechanism*—means, such as linkage, cables, sheaves, and gears, used to produce upper-boom articulation.

3.2.20 *upper-boom tip*—the end of the upper boom to which the platform is attached.

3.3 Abbreviations:

- 3.3.1 *AE*—Acoustic Emission
- 3.3.2 *FRP*—Fiberglass Reinforced Plastic
- 3.3.3 *IAPD*—Insulated Aerial Personnel Device(s)
- 3.3.4 *NDT*—Nondestructive Testing
- 3.3.5 *RLC*—Rated Load Capacity
- 3.3.6 *RPC*—Rated Platform Capacity
- 3.3.7 *SLHA*—Supplemental Load Handling Attachment
- 3.3.8 *SLAC*—Supplemental Load Attachment Capacity

4. Summary of Test Method

4.1 This test method consists of applying a predetermined load to an IAPD while it is being monitored by sensors that are sensitive to acoustic emissions (AE) caused by active defects. These acoustic emissions can be generated by, but are not limited to, the following: crack nucleation movement or propagation in the metal components; or matrix crazing, delamination or fiber breakage of the fiberglass reinforced plastic (FRP) material; or both.

4.2 The IAPD is loaded at a uniform rate until a predetermined load is reached, which is held for a period of time. The load is removed and the cycle is repeated. Acoustic emissions are monitored during both cycles and the data is evaluated.

ASTM F 1430

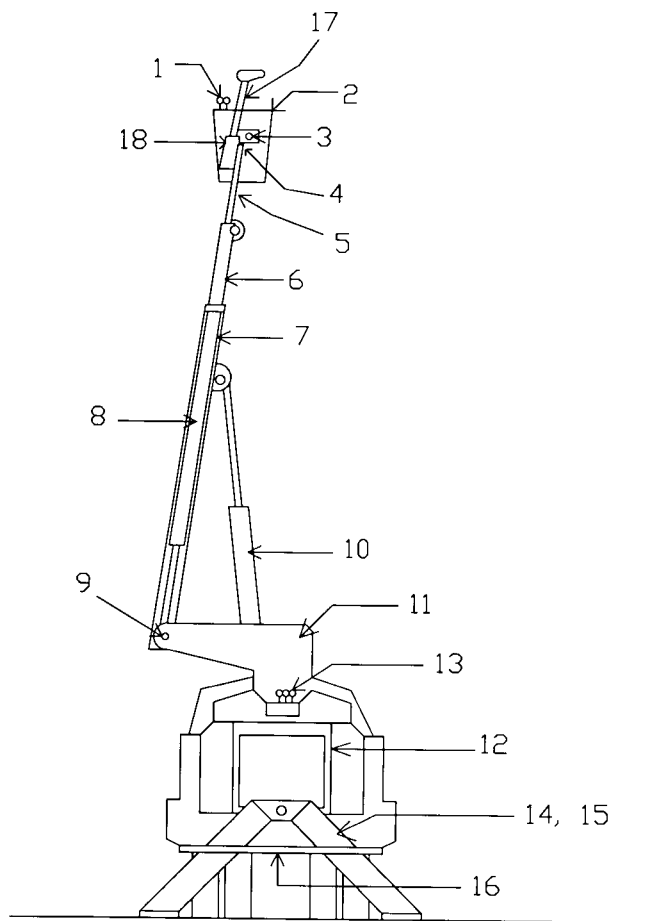

- | | |
|--|---|
| <ul style="list-style-type: none"> 1. Upper Controls 2. Platform 3. Platform Pin 4. Upper Boom Tip 5. Upper Boom 6. Intermediate Boom 7. Lower Boom 8. Extension Cylinder 9. Lower Boom Pin | <ul style="list-style-type: none"> 10. Lift Cylinder 11. Turntable 12. Pedestal 13. Lower Controls 14. Outriggers 15. Outrigger Controls 16. Stabilizers 17. Supplemental Load Handling Attachment Arm 18. Supplemental Load Handling Attachment Bracket |
|--|---|

FIG. 2 Extensible-Boom IAPD Nomenclature Diagram

5. Significance and Use

5.1 This test method provides a means of evaluating acoustic emissions generated by the rapid release of energy from localized sources within an IAPD under controlled loading. The resultant energy releases occur during intentional application of a controlled predetermined load. These energy releases can be monitored and interpreted by qualified individuals.

5.2 This test method permits testing of the major components of an aerial device under controlled loading. This test method utilizes objective criteria for evaluation and may be discontinued at any time to investigate a particular area of concern or prevent a fault from continuing to ultimate failure.

5.3 This test method provides a means of detecting acoustic emissions that may be defects or irregularities, or both, affecting the structural integrity or intended use of the aerial device.

5.4 Sources of acoustic emission found with this test method shall be evaluated by either more refined acoustic emission test methods or other nondestructive techniques

(visual, liquid penetrant, radiography, ultrasonics, magnetic particle, etc.). Other nondestructive tests may be required to locate defects present in IAPDs.

5.5 Defective areas found in aerial devices by this test method should be repaired and retested as appropriate. Repair procedure recommendations are outside the scope of this test method.

6. Personnel Qualifications

6.1 This test method shall be performed by qualified personnel. Qualification shall be in accordance with an established written program, consistent with the established format of ASNT SNT-TC-1A for training, qualification, and certification of personnel for conducting AE testing.

NOTE 2—Personnel performing subsequent nondestructive evaluation (visual, liquid penetrant, radiography, ultrasonic, magnetic particle, etc.) on aerial devices should be certified in accordance with ASNT SNT-TC-1A guidelines.

6.2 Acoustic emission test personnel shall be familiar with

the design, manufacture, and operation of aerial devices. Relevant information is contained in ANSI A92.2 and manufacturers' operating and service manuals.

7. Acoustic Emission Instrumentation

7.1 The AE instrument shall be capable of data acquisition from discrete channels within a frequency band of 20 to 200 KHz. The number of AE instrument channels shall be determined by the attenuation characteristics of the aerial device in order to provide coverage of those components identified in Table 1. A detailed description of instrumentation characteristics is included in Annex A1.

NOTE 3—Use of a minimum of 8 channels does not necessarily imply total coverage of the components identified in Table 1. The instrument should be capable of recording the following: time, events, counts, amplitude, and load. Hard copy records shall be provided by the instrument or available through a direct interface.

8. Test Preparation

8.1 Prior to the AE test, perform a visual observation of the aerial device to determine as far as practicable that the components to be tested are free from any condition that may prohibit the test or adversely affect test results.

8.2 The components to be monitored in an IAPD shall include but not be limited to those listed in Table 1. Additional channels and sensors may be used to supplement the minimum test requirements and improve location resolution.

8.3 Position the sensors on the FRP and metal portions of the components identified in Table 1. The extent of the coverage is determined by the number of sensors used and the attenuation characteristics of the individual components, and can be verified by a simulated AE technique as indicated in Guide E 976. Record the amplitude of the simulated AE source at a distance of 12 in. (304 mm) from the sensor as a reference. Continue to move the simulated AE source away from the sensor until the amplitude is no more than 15 dB less than the reference amplitude. This will establish the maximum area of coverage of the sensor.

8.4 The mounting of sensors shall be in accordance with Practices E 569 and E 650. The couplant used shall not affect the performance of the aerial device.

NOTE 4—The couplant should be compatible with the aerial device; not a possible cause of contamination. The couplant should be completely removable from the surface after testing, leaving the original surface intact.

9. Acoustic Emission (AE) Instrumentation System Performance Check

9.1 Performance verification shall be made with an AE simulator immediately prior to application of test load. This simulator should be capable of producing a transient elastic wave having an amplitude representative of the AE signals to be recorded.

9.2 The AE simulator may be gas jet, pencil lead break technique, or an electronically induced event or equivalent.

9.3 The detected peak amplitude of the simulated event at a fixed distance, typically 6 to 9 in. (152 to 228 mm), from each sensor shall not vary more than 6 dB from the average of all the sensors on the same type material. The detected peak amplitude of any sensor shall not exceed 90 dB to avoid saturation of the preamplifier.

10. System Calibration

10.1 Subject the AE system to a thorough calibration and functional check to verify accurate performance in accordance with the manufacturer's specification, in conjunction with Practice E 750. Perform calibration annually as a minimum in accordance with a written calibration procedure. Include in the calibration, as a minimum: calibration of threshold levels, amplitude measurement circuits, count measurement circuits, AE sensors, and load measuring devices.

10.2 Subject the AE system to a routine calibration check, which shall include as a minimum, verification of threshold levels and amplitude measurement calibration. Perform calibration checks at monthly intervals or after 40 h of operation, whichever is more frequent.

11. Procedure

11.1 Test articulating-boom IAPDs in positions such that the components indicated in Table 1 can be monitored. Recommended test positions as illustrated in Fig. 3, Fig. 4, or their equivalents may be used.

11.2 Test extensible-boom IAPDs in positions such that the components indicated in Table 1 can be monitored. Recommended test positions as illustrated in Fig. 5 or their equivalents may be used.

11.3 Attach the load measuring device to the load application system which in turn shall be attached to an adequate dead weight or anchor.

11.4 Employ the following methods to provide sufficient load on the aerial lift to evaluate its structural condition using AE techniques.

11.4.1 Apply the test load(s) to the platform(s) in accordance with Test Method F 914. The method of load application and attachment to the platform shall not permanently deform the platform.

11.4.2 The method of load application and attachment to the

TABLE 1 IAPD Components to Be Monitored with Acoustic Emission

Component ^A	Identification	Articulating-Boom IAPD	Extensible-Boom IAPD
Platform	A	X ^B	X
Platform Attachment	B	X	X
Upper Boom	C	X	X
Upper and Lower Boom Attachment of Elbow	D	X	NA ^C
Upper and Lower Section of Lower Boom	E	X	NA
Lower Boom Insulator	F	X	NA
Turntable and Rotation Bearing	G	X	X
Pedestal	H	X	X
Intermediate Boom	I	NA	X
Lower Boom	J	NA	X
Supplemental Load Attachment Arm	K	X	X
Supplemental Load Attachment Bracket	L	X	X

^ARefer to Figs. 1 and 2 for illustration of components.

^BThe use of the symbol "X" indicates the need to monitor this component with acoustic emission.

^CThe use of the symbol "NA" indicates that acoustic emission does not apply.

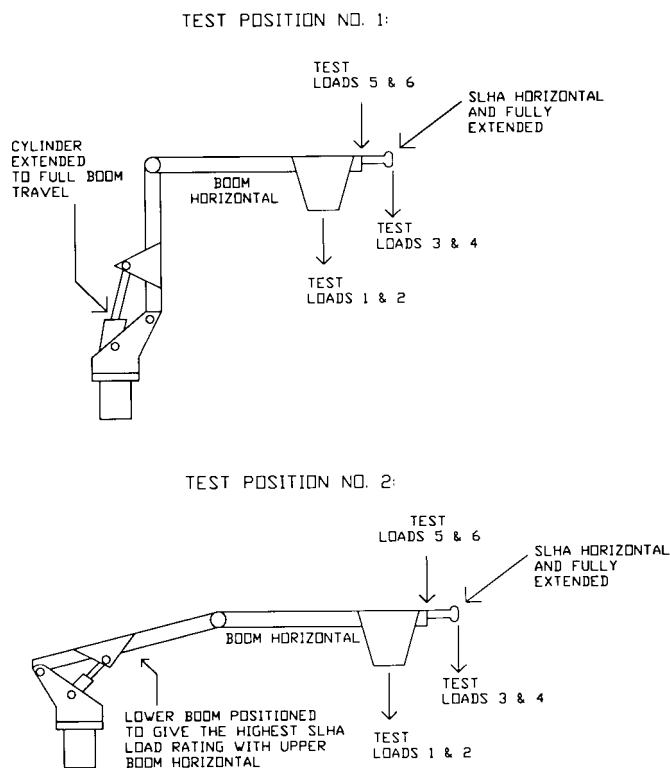

The following notes apply to Figs. 3(a), 3(b), and 4:

- NOTE 1—Refer to Fig. 5 for test loads.
- NOTE 2—Position the truck in the most favorable stable position, on firm, level ground.
- NOTE 3—Extend the outriggers.
- NOTE 4—Refer to the manufacturers' load charts, operational manuals, and decals before testing.
- NOTE 5—Maintain weights (test loads) within 2 ft of the ground at all times.
- NOTE 6—The unit must be tested in both positions.

FIG. 3 Overcenter Articulating-Boom IAPD Recommended Test Positions and Test Loads

SLHA shall simulate in-field use as closely as possible.

11.4.3 The test loads applied to an IAPD shall be as follows:

11.4.3.1 The test load applied to the aerial device platform(s) shall be two times the rated platform capacity (RPC).

11.4.3.2 The test load applied to the IAPD supplemental load handling attachment (SLHA) shall be one and one half times the supplemental load attachment capacity (SLAC) with the attachment oriented to position the supplemental load at the maximum horizontal reach from the platform pin. The test load shall not exceed two times the rated load capacity (RLC) of the IAPD.

11.4.3.3 The test load applied to the end of the upper boom shall be two times the RLC of the IAPD.

11.5 All components of the load application system shall be capable of supporting the test load.

11.6 As a minimum, record the following data during the test:

- 11.6.1 Events by channel (events versus time),
- 11.6.2 Counts versus time or load for metal channels,
- 11.6.3 Counts versus time or load for fiberglass channels,

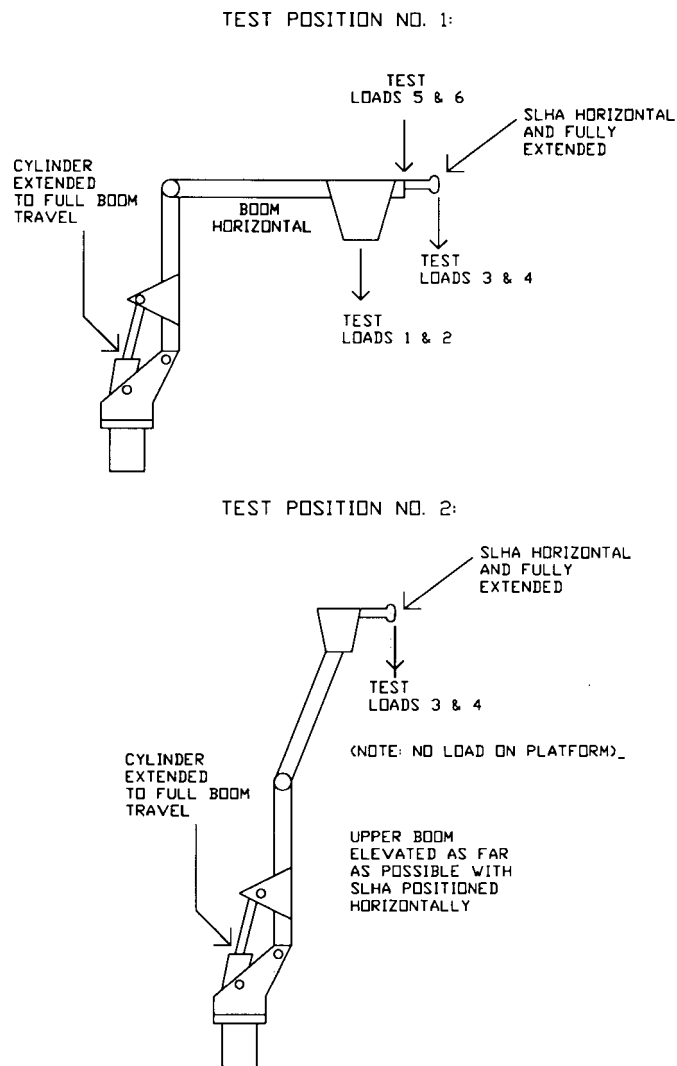

FIG. 4 Non-overcenter Articulating-Boom IAPD Recommended Test Positions and Test Loads

- 11.6.4 Amplitude distribution for metal channels,
- 11.6.5 Amplitude distribution for fiberglass channels, and
- 11.6.6 Load versus time.

11.7 If any test inputs indicate to the operator that damage could be occurring to the device, stop the test and evaluate the condition or resolve the condition, or both, prior to restarting the test. Otherwise, complete the test procedure as outlined in 11.8.

NOTE 5—The following AE data can be used as guidelines for determining when the test should be stopped immediately for fear of damage. These guidelines are not acceptance criteria:

- (a) More than 150 total first-hit events with amplitude greater than 70 dB on FRP and metal channels combined.
- (b) More than 150 000 total first-hit counts with amplitude greater than 40 dB on FRP and metal channels combined.

11.8 Perform the loading sequence as illustrated in Fig. 6 or a suitable alternative sequence (see Appendix X1).

11.8.1 For 2 min prior to applying the load, use the AE instrumentation to detect background noise. If any background noise is observed, identify the source of the noise, and if possible, eliminate such before loading begins. If the background noise is excessive, reschedule the test for another time

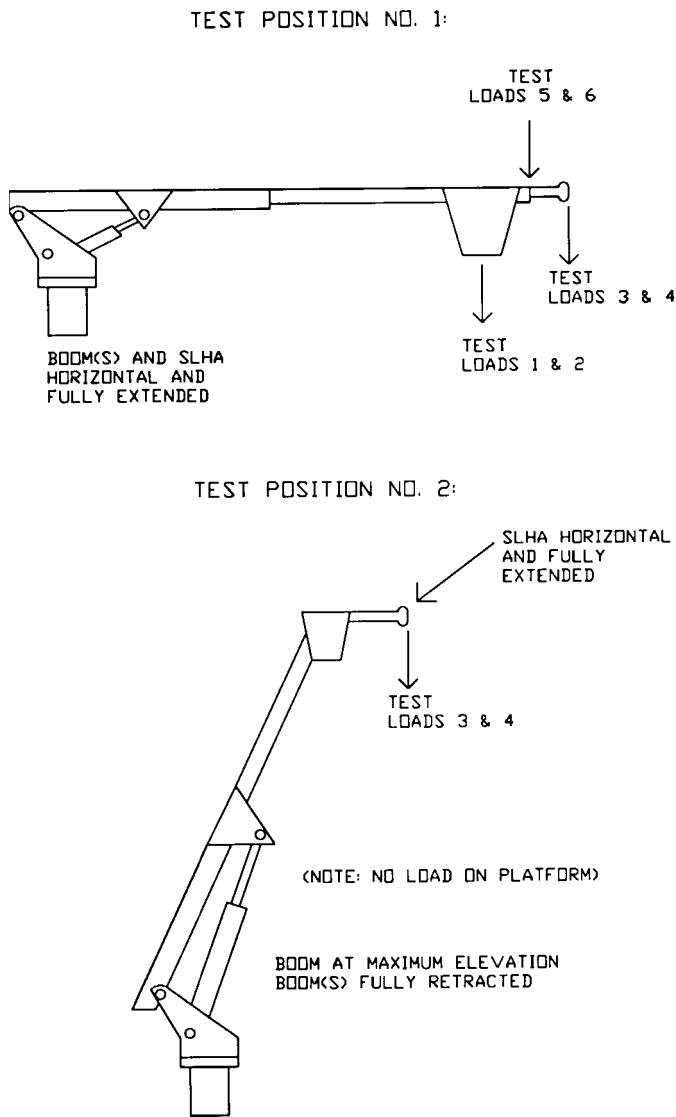

FIG. 5 Extensible-Boom IAPD Recommended Test Positions and Test Loads

or location in order to eliminate the excessive background noise. Examples of potential background noise sources include electromagnetic interference, close proximity to radio stations, improper grounding, rubbing interfaces, and impact.

11.8.2 Platform Loading Sequence:

11.8.2.1 Apply a test load equal to twice the rated platform capacity, at a uniform rate, between 3 and 10 lbf/s, until the test load is attained. (**Caution:** Do not exceed twice the RLC.)

11.8.2.2 Hold the test load for 4 min.

NOTE 6—The leak down rate of the aerial personnel device's hydraulic system could invalidate the AE data.

11.8.2.3 Remove the load at a uniform rate, between 6 and 20 lbf/s.

11.8.2.4 Wait a minimum of 4 min prior to proceeding with the loading sequence.

11.8.2.5 Repeat 11.8.2.1-11.8.2.4.

11.8.3 SLHA Loading Sequence:

11.8.3.1 At the end of the 4-min waiting period, apply a test load equal to one and one half times the rated supplemental

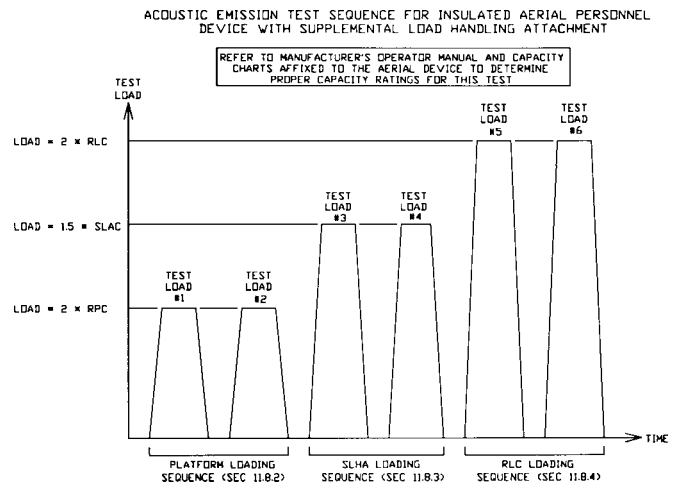

FIG. 6 IAPD Acoustic Emission Test Sequence

load attachment capacity to the supplemental load attachment at a uniform rate between 10 and 30 lbf/s until the supplemental load attachment test load is attained. (**Caution:** Do not exceed twice the RLC.)

11.8.3.2 Hold the test load for 4 min.

11.8.3.3 Remove the load at a uniform rate, between 20 and 40 lbf/s.

11.8.3.4 Wait a minimum of 4 min prior to proceeding with the loading sequence.

11.8.3.5 Repeat 11.8.3.1-11.8.3.4.

11.8.4 RLC Loading Sequence:

11.8.4.1 At the end of the 4-min waiting period, apply a test load equal to twice the rated load capacity of the aerial device to the end of the upper boom at a uniform rate between 10 and 30 lbf/s until the test load is attained.

11.8.4.2 Hold the test load for 4 min.

11.8.4.3 Remove the test load at a uniform rate between 20 and 40 lbf/s.

11.8.4.4 Wait a minimum of 4 min prior to proceeding with the loading sequence.

11.8.4.5 Repeat 11.8.4.1-11.8.4.3.

11.9 For each additional test position, repeat 11.8-11.8.4.5.

11.10 Pass/Fail Criteria for Emission Testing of FRP Components:

11.10.1 The following acceptance criteria are valid only when using this test method and applied loads remain constant during hold cycles. The following A/E responses from monitoring FRP components constitute acceptance:

11.10.1.1 Zero events or counts, or both, during the last 3 min of the second hold, at test load, or,

11.10.1.2 Fewer total events or counts, or both, recorded during the second hold period at test load than the total events or counts, or both, recorded during the first hold period (Kaiser effect). A clear reduction in the rate of acoustic activity over both hold periods should also be observed (that is, the slope of events/time or counts/time decreases over the hold periods).

11.10.2 Acoustic responses outside the preceding described parameters are unacceptable to this test method. Suitability for service of FRP components that do not meet this test method must be carefully evaluated.

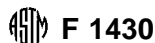

12. Report

12.1 *Test Instrumentation*—Include instrument settings in all reports submitted for the examination. They shall be signed and dated by the responsible qualified personnel performing the tests. The information recorded shall be sufficient to permit complete reanalysis of the results. The information shall include, but is not limited to the following:

12.1.1 Sensor manufacturer, model number, nominal peak frequency response, and serial number,

12.1.2 Methods of sensor attachment and type of couplant, and

12.1.3 Diagram or sketch of sensor locations including a description indicating areas of coverage.

12.2 *Aerial Device*—All submitted reports of the examination shall include, but not be limited to the following information:

12.2.1 The aerial device manufacturer, model, serial number, and year of manufacture,

12.2.2 General description including rated platform capacity of the insulated personnel aerial device, and

12.2.3 Modifications, changes, repairs, and damage or suspected damage to the aerial device.

12.3 *Other Test Information:*

12.3.1 Report the description of load application and measured test load sequence:

12.3.1.1 Identify the type of load application; that is, constant load versus time or constant displacement versus time, and

12.3.1.2 The variation of load versus time during each of the load hold periods in pounds or percent of full load.

12.4 Report the following information:

12.4.1 The method used for determination of the test load,

12.4.2 Permanent data record in the form of charts, graphs, or event line listings, or a combination thereof,

12.4.3 Ambient conditions during test, such as wind, temperature, rain, etc., and

12.4.4 Any additional information that may be of use.

12.5 Any departure from the procedures specified in this test method shall be adequately justified and documented in the test record.

13. Precision and Bias

13.1 Each testing agency has the responsibility of judging the acceptability of its own results. The precision of the results is a function of the procedures, and facilities utilized, as well as compliance to the recommended industry state-of-the-art practices. Reproducible analysis determinations by different users can be achieved only with identical facilities and trained conscientious personnel.

ANNEX

(Mandatory Information)

A1. INSTRUMENT PERFORMANCE REQUIREMENTS

A1.1 *Sensors*—AE sensors shall be stable over the temperature range of use and shall not exhibit sensitivity changes greater than 3 dB over this range. Sensors shall be shielded against radio frequency and electromagnetic noise interference through proper shielding practice or differential (anticoincident) element design, or both. Sensors shall have omnidirectional response, with variations not exceeding 4 dB from the peak response.

A1.1.1 High-frequency sensors, used on metal components of the aerial device, should have the primary resonant frequency at 150 ± 10 kHz. Minimum sensitivity shall be -80 dB referred to 1 V per microbar, or -40 dB for integral preamp sensors as determined by face-to-face ultrasonic swept-frequency calibration. AE sensors should not vary in sensitivity more than 3 dB from the average.

A1.1.2 Low-frequency sensors, used on fiberglass components of the aerial device, should have the primary resonant frequency at 60 ± 10 kHz. Minimum sensitivity shall be equivalent or greater than high-sensitivity accelerometers designed for use at 60 kHz.

A1.1.3 Up to two sensors may be commoned into a single channel.

A1.2 *Signal Cable*—The signal cable from sensor to preamplifier shall not exceed 6 ft (1.8 m) in length and shall be

shielded against electromagnetic interference. This requirement is omitted where the preamplifier is mounted in the sensor housing, or a line-driving (matched impedance) sensor is used.

A1.3 *Preamplifier*—The preamplifier may be separate or may be mounted in the sensor housing. For sensors with integral preamplifiers, frequency response characteristics may be confined to a range consistent with the operational frequency of the sensor. If the preamplifier is of differential design, a minimum of 40 dB of common-mode noise rejection shall be provided. Unfiltered frequency response shall not vary more than 3 dB over the frequency range from 20 to 400 kHz, and over the temperature range of use.

A1.4 *Filters*—Filters shall be of the band pass or high pass type, and shall provide a minimum of -24 dB/octave signal attenuation. Filters may be located in preamplifier or post-preamplifier circuits, or may be integrated into the component design of the sensor, preamplifier, or processor to limit frequency response. Filters or integral design characteristics, or both, shall ensure that the principal processing frequency for high-frequency sensors is not less than 100 kHz, and for low-frequency sensors, not less than 25 kHz.

A1.5 *Power-Signal Cable*—The cable providing power to the preamplifier and conducting the amplified signal to the main

processor shall be shielded against electromagnetic noise. Signal loss shall be no more than 1 dB/100 ft (30.4 m) of cable length. Five hundred feet (152 m) is the recommended maximum cable length to avoid excessive signal attenuation. Digital or radio transmission of signals is allowed consistent with standard practice in transmitting those signal forms.

A1.6 Main Amplifiers—The main amplifier, if used, shall have signal response with variations not exceeding 3 dB over the frequency range from 20 to 400 kHz, and temperature range of use. The main amplifier shall have adjustable gain, or an adjustable threshold for event detection and counting.

A1.7 Main Processor:

A1.7.1 General—The main processors shall have a minimum of eight independent channel inputs for signal processing of events. If mixer(s) are used, first-hit event processing for each channel must be provided.

A1.7.1.1 Independent processing of counts, events, and amplitude (per event) for each channel is preferred; but as a minimum, two active processing circuits shall process counts and amplitude information from metal and fiberglass channels independently.

A1.7.1.2 The system shall be capable of processing and storing at least 100 events/s for limited periods of time.

A1.7.2 Peak Amplitude Detection—Usable dynamic range shall be a minimum of 60 dB with 5 dB resolution over the frequency band from 20 to 400 kHz, and the temperature range of use. Not more than 2 dB variation in peak detection accuracy shall be allowed over the stated temperature range. Amplitude values may be stated in volts or dB, but must be

referenced to a fixed gain output of the system (sensor or preamp).

A1.7.3 Source Location—Source location using time difference processing between channels is optional, and may be used where it improves source identification on the structure. However, use of the source location algorithms shall not prohibit processing of individual or first-hit sensor information.

A1.7.4 Signal Outputs and Recording—The processor shall provide as a minimum outputs for permanent recording of the following:

A1.7.4.1 Events by channel (events versus time).

A1.7.4.2 Counts versus time or load for metal channels,

A1.7.4.3 Counts versus time or load for fiberglass channels,

A1.7.4.4 Amplitude distribution for metal channels,

A1.7.4.5 Amplitude distribution for fiberglass channels, and

A1.7.4.6 Load versus time.

NOTE A1.1—The required outputs should be based on first-hit information.

A1.7.5 Load-Measuring Device—The load cell or other load-measuring device shall be capable of registering the loads applied during testing within its calibration range. The device shall be calibrated in a manner and at intervals recommended by the manufacturer's specifications. The percent error for loads within the loading range of the load cell and readout shall not exceed $\pm 1.0\%$ of the reading. In load readouts that possess multiple-capacity ranges, the verified loading of each range shall not exceed $\pm 1.0\%$ of the reading. An electronic output of the load measuring device, proportional to applied load, shall be properly conditioned and amplified to match the requirements of the recording device used.

APPENDIX

(Nonmandatory Information)

X1. ALTERNATIVE LOADING SEQUENCES

X1.1 Test procedures in this test method require testing of IAPDs to twice (2X) rated load capacity and that both the platform(s) and the supplemental load-handling attachment also be tested to twice their rated capacity. In order to assure that twice the rated capacity of these components is not exceeded and that all components are appropriately loaded for testing, loading sequences other than that described in this test method can be utilized. Examples of these alternative loading sequences are as follows:

X1.1.1 Two times the rated platform(s) capacity applied at the platform(s) plus two times the remaining rated load capacity applied at the supplemental load-handling attachment provided this does not exceed two times the supplemental load-attachment capacity. An additional test may be required to completely load the supplemental load-handling attachment to twice its rated capacity.

X1.1.2 Two times the rated load capacity applied at the supplemental load-handling attachment provided this does not exceed two times the supplemental load-attachment capacity. An additional test would be performed to test the platform(s) to twice its rated capacity. An additional test may be required to completely load the supplemental load-handling attachment to twice its rated capacity.

X1.1.3 One and one half times the supplemental load-attachment capacity applied at the supplemental load-handling attachment plus the remainder of two times the rated load capacity applied at the platform(s) provided this does not exceed twice the rated platform capacity. An additional test may be required to completely load the platform(s) to twice its rated capacity.

**NOTICE: This standard has either been superseded and replaced by a new version or discontinued.
Contact ASTM International (www.astm.org) for the latest information.**



The American Society for Testing and Materials takes no position respecting the validity of any patent rights asserted in connection with any item mentioned in this standard. Users of this standard are expressly advised that determination of the validity of any such patent rights, and the risk of infringement of such rights, are entirely their own responsibility.

This standard is subject to revision at any time by the responsible technical committee and must be reviewed every five years and if not revised, either reapproved or withdrawn. Your comments are invited either for revision of this standard or for additional standards and should be addressed to ASTM Headquarters. Your comments will receive careful consideration at a meeting of the responsible technical committee, which you may attend. If you feel that your comments have not received a fair hearing you should make your views known to the ASTM Committee on Standards, at the address shown below.

This standard is copyrighted by ASTM, 100 Barr Harbor Drive, PO Box C700, West Conshohocken, PA 19428-2959, United States. Individual reprints (single or multiple copies) of this standard may be obtained by contacting ASTM at the above address or at 610-832-9585 (phone), 610-832-9555 (fax), or service@astm.org (e-mail); or through the ASTM website (www.astm.org).