



# Standard Specification for Unused Polypropylene Rope with Special Electrical Properties<sup>1</sup>

This standard is issued under the fixed designation F 1701; the number immediately following the designation indicates the year of original adoption or, in the case of revision, the year of last revision. A number in parentheses indicates the year of last reapproval. A superscript epsilon ( $\epsilon$ ) indicates an editorial change since the last revision or reapproval.

## 1. Scope

1.1 This specification covers the requirements, sizes, construction, tests, and procedures for unused polypropylene ropes for use by electrical utilities and related industries on energized lines operating at voltages higher than 1 kV.

1.2 This specification covers the minimum electrical, mechanical, and physical properties guaranteed by the manufacturer and the detailed procedures by which such properties are to be determined. The purchaser has the option to perform or have performed any of these tests in order to verify the guarantee. Claims for failure to meet the specification are subject to verification by the manufacturer.

1.3 The rope to which this specification applies is designed to be used in a clean and dry condition, on or near energized lines.

1.4 A margin of safety shall be allowed between the maximum voltage and working distances on which it is used and the test voltage and lengths at which it is tested.

1.5 It is common practice for the user of this type of equipment to prepare complete instructions and regulations to govern in detail the correct and safe use of such equipment.

1.6 The use and maintenance of this equipment is beyond the scope of this specification.

1.7 The values stated in SI units are to be regarded as the standard.

1.8 The following safety hazards caveat pertains only to the test method portion, Section 13, of this specification: *This standard does not purport to address all of the safety concerns, if any, associated with its use. It is the responsibility of the user of this standard to establish appropriate safety and health practices and determine the applicability of regulatory limitations prior to use.*

## 2. Referenced Documents

### 2.1 ASTM Standards:

D 1125 Test Methods for Electrical Conductivity and Resistivity of Water<sup>2</sup>

D 4268 Test Methods for Testing Fiber Ropes<sup>3</sup>

<sup>1</sup> This specification is under the jurisdiction of ASTM Committee F18 on Electrical Protective Equipment for Workers and is the direct responsibility of Subcommittee F18.35 on Tools and Equipment.

Current edition approved April 10, 1996. Published August 1996.

<sup>2</sup> *Annual Book of ASTM Standards*, Vol 11.01.

<sup>3</sup> *Annual Book of ASTM Standards*, Vol 07.02.

E 4 Practices for Force Verification of Testing Machines<sup>4</sup>  
E 380 Practice for Use of the International System of Units (SI) (the Modernized Metric System)<sup>5</sup>  
F 711 Specification for Fiberglass-Reinforced Plastic (FRP) Rod and Tube Used in Live Line Tools<sup>6</sup>

### 2.2 IEEE Standards:

IEEE Std 4 Standard Techniques for High Voltage Testing<sup>7</sup>  
IEEE Paper Field and Test Experience With Insulating Rope at BPA (July 1991)<sup>7</sup>

### 2.3 ISO Standard:

ISO 2307 Ropes —Determination of Certain Physical and Mechanical Properties<sup>8</sup>

### 2.4 Other Standard:

Cordage Institute CIA-3 Standard test methods fibre rope including standard terminations for hollow braided rope and double braided rope (June 1980)<sup>9</sup>

## 3. Terminology

3.1 *General*—The terms used in this specification are common to and well known by the industries that will be using them.

## 4. Ordering Information

4.1 Orders for rope under this specification should include the following information:

4.2 Manufacturer's designation of the rope.

4.3 *Length of Coil or Reel*:

4.3.1 *Lengths*—Unless otherwise specified, rope shall be furnished in lengths described for size in Table 1. Each package shall be continuous throughout without splices or knots. Ends shall be taped, heat sealed, or served to prevent ravelling.

4.3.2 *Special Lengths*—Lengths other than listed in Table 1 to be negotiated with the vendor.

4.3.3 Rope should be shipped in reels.

4.4 *Weight*—The weight per 100 ft of rope shall be as specified in Table 1. Rope weight more than 5 % in excess for

<sup>4</sup> *Annual Book of ASTM Standards*, Vol 03.01.

<sup>5</sup> *Annual Book of ASTM Standards*, Vol 14.02.

<sup>6</sup> *Annual Book of ASTM Standards*, Vol 10.03.

<sup>7</sup> Available from the Institute of Electrical and Electronics Engineers, Inc., 345 E. 47th St., New York, NY 10017.

<sup>8</sup> Available from the American National Standards Institute, 11 West 42nd St., 13th Floor, New York, NY 10036.

<sup>9</sup> Available from Cordage Institute.

**TABLE 1 Dimensions, Mass, and Permissible Variations**

Nominal Diameter, in.	Nominal Circumference, in.	Minimum Breaking Test, lb	Nominal Weight, lb/100 ft	Standard Length, ft
¼	¾	1300	1.65	1200
⅜	1⅛	2950	4.0	1200
7/16	1¼	3750	4.6	1200
½	1½	4850	6.0	1200
9/16	1¾	5750	7.2	1200
5/8	2	7000	9.9	1200
¾	2¼	9450	13.1	1200
7/8	2¾	12 600	17.0	1200
1	3	15 300	20.7	1200
1⅛	3½	19 350	28.0	1200

size as billed by the vendor shall be reduced by such excess weight. The weight shall be determined in accordance with Cordage Institute Standard test methods.

4.4.1 Rope is billed by weight. If rope is supplied by the vendor that weighs more than 5 % in excess for the size, the total weight will be reduced to the maximum weight allowed for billing purposes.

NOTE 1—For example, (1) 7/8 in. rope maximum weight 17.0 lb/100 ft; (2) 5 % excess weight allows 17.85 lb/100 ft; (3) 100 ft of rope is delivered that weighs 18.0 lb. The billable weight would be reduced to 17.85 lb.

4.5 *Test Facility*—The test facility for the electrical and mechanical tests will be agreed to by the manufacturer/seller and the buyer.

4.6 *Standard Atmospheric Conditions*—The atmospheric condition shall be substantially at a temperature of  $22 \pm 5^\circ\text{C}$  ( $72 \pm 9^\circ\text{F}$ ) and relative humidity of 35 % minimum and negligible air movement.

## 5. Materials and Manufacture

5.1 *Materials*—The rope filaments used shall be 100 % oriented polypropylene having a minimum tenacity of 5.0 g per denier strength. The fiber shall be fortified to stabilize and retard degradation due to oxidation and ultraviolet decay. The use of undrawn fiber is prohibited (inside yarns may be clean and unfortified).

5.2 *Manufacture*—Rope shall be 3-strand; sizes ¼ through ½ in. diameter ropes shall be from single ply yarns or 3 ply yarns of approximately 12 000 to 22 000 denier as a maximum for singles and 15 000 denier as a maximum for the component of the ply. Rope sizes 9/16 in. diameter and larger shall be constructed from 3-ply yarns; the subyarn (component) shall contain a maximum of 15 000 denier. The lay for all rope shall be right hand or “Z” lay. Rope shall be “F” (firm) lay to maintain best dimensional stability under load.

5.2.1 See Table 1 for values.

## 6. Physical Properties

6.1 *Color*—The color of the rope shall be orange. A maximum of two outside tracers for customer or manufacturer identification, or both, may be used. Tracers shall be 100 % polypropylene.

6.2 *Circumference*—The nominal circumference and diameter sizes are listed in Table 1.

6.3 *Hardness*—Refer to 13.5.

6.4 *Lay, Diameter, and Gage Length*—Refer to 13.5.

6.5 *Melt Point*—Refer to 13.5.

## 7. Mechanical Properties

7.1 The primary mechanical property of rope is the breaking strength. The minimum breaking strengths for the various sizes of rope are listed in Table 1.

## 8. Dimensions, Mass and Permissible Variations

8.1 The dimensions, mass, and applicable permissible variations are found in Table 1.

## 9. Workmanship, Finish, and Appearance

9.1 All sizes of rope shall be evenly laid and well balanced in accordance with best rope making workmanship. Rope and strands shall be free from kinks, strand knots, and darting yarns or loose ends (inside yarns which project through cover yarns of strand at intervals along the rope).

## 10. Sampling and Number of Tests or Retests

10.1 *Composition of Batch to be Sampled*—Samples shall be taken from a homogeneous batch consisting of ropes of the same size and same dimensions and which have been subject to the same series of manufacturing operations and the same checking procedure.

10.2 *Selecting the Samples*—Unless otherwise agreed upon between the purchaser and manufacturer, take at random from the batch the number of samples,  $S$ , obtained from the following equation:

$$S = 0.4 \sqrt{N}$$

where  $N$  = number of coils making up the batch. Where the calculated value of  $S$  is not a whole number, the number obtained shall be rounded to the nearest whole number. For example, 27.5 and 30.35 shall be rounded to 28 and 30, respectively. Where  $S < 1$ , take one sample length.

10.3 *Specimen Selection Location*—For coils, specimens shall be selected from each end. For rope made and shipped in reel lengths, one specimen shall be selected from the outside end and one from the inside (drum) end.

10.3.1 This requirement will require a re-reeling of the rope.

## 11. Specimen Preparation

11.1 Specimen preparation is included as a part of each test method. The ends of each rope specimen shall be heat scaled.

## 12. Recommended Working Load

12.1 Manufacturers furnishing rope under this specification shall specify a recommended maximum working load.

NOTE 2—A minimum breaking load is specified in Table 1.

## 13. Test Methods and Performance Requirements

13.1 The polypropylene ropes complying with these specifications shall undergo two different tests, electrical and mechanical/physical, and are to be termed “nonconductive” rope. Samples of rope selected in accordance with Section 10 from every lot (single finished production length) shall be tested and each reel identified by lot (see 4.3). If single-finished

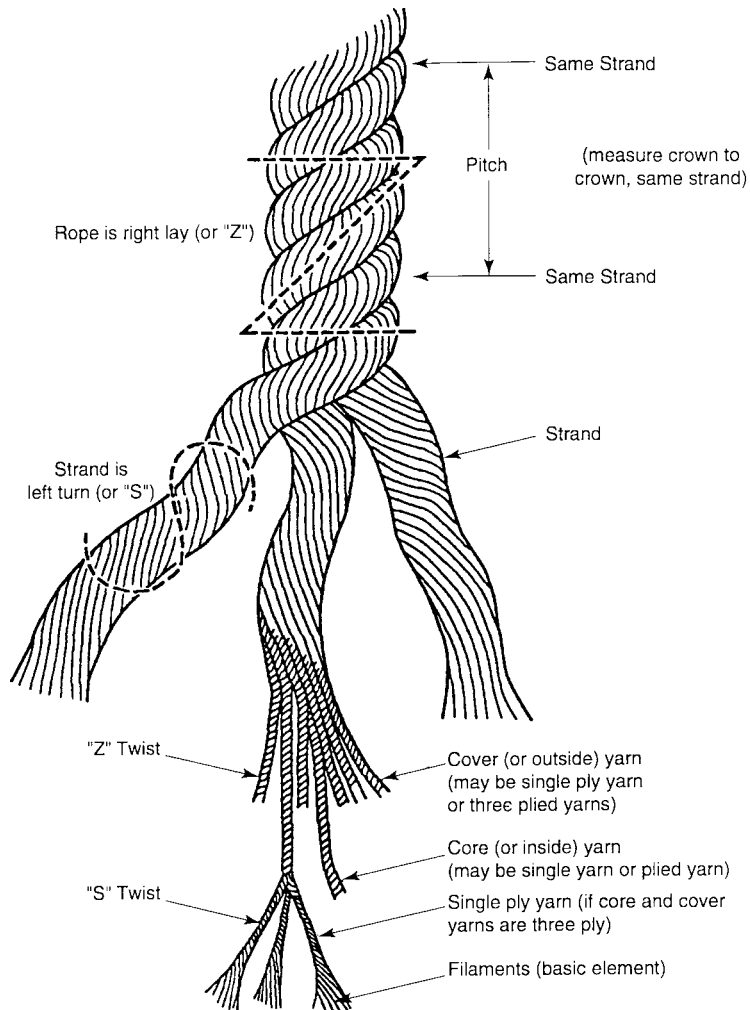

FIG. 1 Polypropylene Rope With Special Electrical Properties

production length is greater than 1828 m (6000 ft) then tests shall be conducted at the beginning and end of the finished production length.

13.1.1 The test sequence is (1) visual; (2) electrical; (3) mechanical/physical.

13.2 **Caution**—It is recommended that the test apparatus be designed to afford the operator full protection in performance of his duties. Reliable means of deenergizing and grounding the high-voltage circuit shall be provided.

13.3 *Electrical Test Procedure—Wet Test*—This is a routine production test.

13.3.1 *Specimen for Test*—The test specimen shall be at least 2.4 m (8 ft) long so that when the rope is held in a vertical position, there will be 1.5 m (5 ft) of rope free of knots, eyes, or splices.

13.3.2 *Handling of Specimen*—When the specimen is handled, it shall always be outside the test footage (see Fig. 2).

13.3.3 *Attachment of Electrodes*—The electrodes shall be attached prior to wetting the specimen. See Fig. 2 for attachment points. The electrode shall be made of one wrap of 22 gage solid copper wire twisted tightly and pigtailed to ensure all filaments are in contact. See Fig. 2.

13.3.4 *Wetting of Specimen:*

13.3.4.1 A clean nonmetallic tank or trough shall be rinsed

with the same type water to be used during the wetting.

13.3.4.2 The entire rope specimen shall be kept submerged horizontally in test water at a depth of 305 mm (1 ft) using non-metallic device(s) for a period of 15 min. There shall be no bends in this specimen.

13.3.5 *Water for Wetting*—The electrical resistivity of the water used for wetting shall meet the requirements of IEEE Standard 4, that is 100  $\Omega$  m at ambient temperature  $\pm$  15°C. The resistivity may be measured by using the test methods as described in Test Methods D 1125.

13.3.6 *Drying of Specimen*—Within 1 min after removing specimen from wetting tank, the specimen shall be hung in a vertical position with an unrestrained weight of 4.5 kg (10 lb) attached. Allow to dry at as near standard atmospheric conditions as practical with rope attachment point and weight attachment point as described in Fig. 2. The specimen shall be allowed to dry for 15 min.

13.3.7 *Leakage Readings:*

13.3.7.1 The 60 Hz voltage shall be applied immediately after the 15-min drying period and shall be raised from 0 to 30 kV in not less than 5 nor more than 15 s. The voltage shall be held at 30 kV for 30 s. The leakage current obtained over the 2 ft test section shall not exceed 50  $\mu$ A from the time of initial application of voltage until the end of the test. If the current

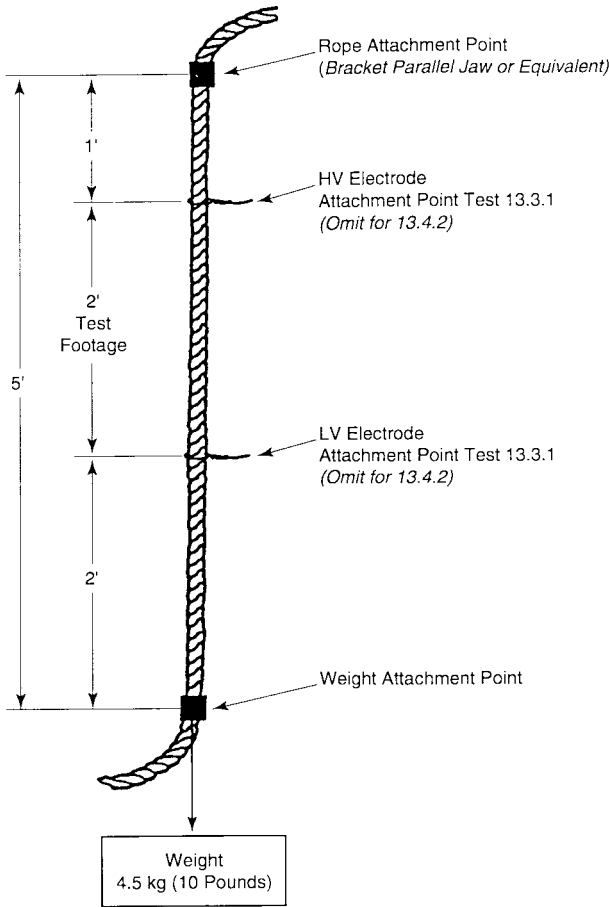
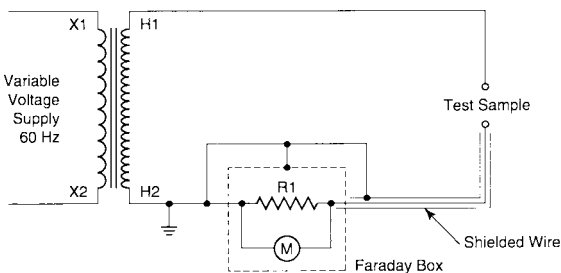

FIG. 2 Test Configuration for Electrical Routine Production Test

exceeds 50  $\mu$ A, the lot will be rejected. Refer to Fig. 3 for test circuit.

13.3.7.2 The wet test in 13.3.1 is a discriminatory test used as a method of determining the rope quality, not as a method of determining the rope's ability to operate properly under wet conditions in the field.



Legend:

*Faraday Box*—a shielded container (continuous copper screen, with a suitable mounting frame) enclosing and guarding the dropping resistor *R 1*, and *M* (VM). Both the screen, and shield of the measuring lead, by-pass *R1* and *M*, by providing a path for stray capacitive currents to ground.

*R 1*—100  $\Omega$ , 50 W wire wound noninductive resistor. A minimum 50 W resistor is recommended because a hazardous condition would exist if the resistor should burn open.

*M*—battery operated, true RMS, solid state voltmeter. Read drop across *R 1* and calculate current  $I = E/R$

FIG. 3 Electrical Test Circuit

13.4 *Electrical Test Procedure—Acceptance Test*—This is a dry specimen acceptance test.

13.4.1 *Specimen for Test*—The test specimen shall be at least 2.4 m (8 ft) long so that when the rope is held in a vertical position, there will be 1.5 m (5 ft) of rope free from knots, eyes, or splices (see Fig. 2).

13.4.2 *Handling of Specimen*—When the rope is handled, it shall always be outside the test footage (see Fig. 2).

13.4.3 *Electrodes:*

13.4.3.1 The electrodes shall be designed to shield out the majority of stray capacitive currents.

13.4.3.2 The electrodes shall be similar to those specified in Specification F 711 for testing FRP rod and tube. Electrical contact is made through washers that fit snugly around the rope. The electrodes shall be mounted in a suitable frame to allow the suspension of the 305 mm (12 in.) test section between the electrodes. A4.5 kg (10 lb) weight shall be attached to the rope to maintain good electrical contact. See Fig. 4. For alternative electrode design, see Fig. 5.

13.4.4 *Dry Test Leakage Readings*—The 60 Hz voltage shall be raised from 0 to 100 kV rms in not less than 5 nor more than 15 s. The voltage shall be held at 100 kV rms for 5 min. If at the end of 5 min the current is stable and has not exceeded 100  $\mu$ A or flashed over, the specimen has passed the test. If at the end of 5 min the current is not stable and does not exceed 100  $\mu$ A, or flashover, the test shall continue for an additional 25 min. If at the end of that time the rope has not flashed over and the current has stabilized at less than 100  $\mu$ A, the specimen has passed.

NOTE 3—The acceptance tests may be performed at the option of the purchaser to verify that the product meets the criteria of 13.4. The cost of these tests is negotiable between the purchaser and the manufacturer.

13.5 *Wet Acceptance Test:*

13.5.1 *Specimen for Test*—The test specimen shall be at least 2.4 m (8 ft) long so that when the rope is held in a vertical position, there will be 1.5 m (5 ft) of rope free from knots, eyes, or splices (see Fig. 2).

13.5.2 *Handling of Specimen*—When the rope is handled, it shall always be outside the test footage (see Fig. 2).

13.5.3 *Electrodes:*

13.5.3.1 The electrodes shall be designed to shield out the majority of stray capacitive currents.

13.5.3.2 The electrodes shall be similar to those specified in Specification F 711 for testing FRP rod and tube. Electrical contact is made through washers that fit snugly around the rope. The electrodes shall be mounted in a suitable frame to allow the suspension of the 305 mm (12 in.) test section between the electrodes. A4.5 kg (10 lb) weight shall be attached to the rope to maintain good electrical contact. See Fig. 4.

13.5.4 *Wetting of Specimen:*

13.5.4.1 A clean nonmetallic tank or trough shall be rinsed with the same type water to be used during the wetting.

13.5.4.2 The entire rope specimen shall be kept submerged horizontally in test water at a depth of 305 mm (1 ft) using nonmetallic device(s) for a period of 15 min. There shall be no bends in this specimen.

13.5.5 *Water for Wetting*—The electrical resistivity of the

ELECTRICAL TEST CARRIED OUT DRY AND AFTER MOISTURE ABSORPTION

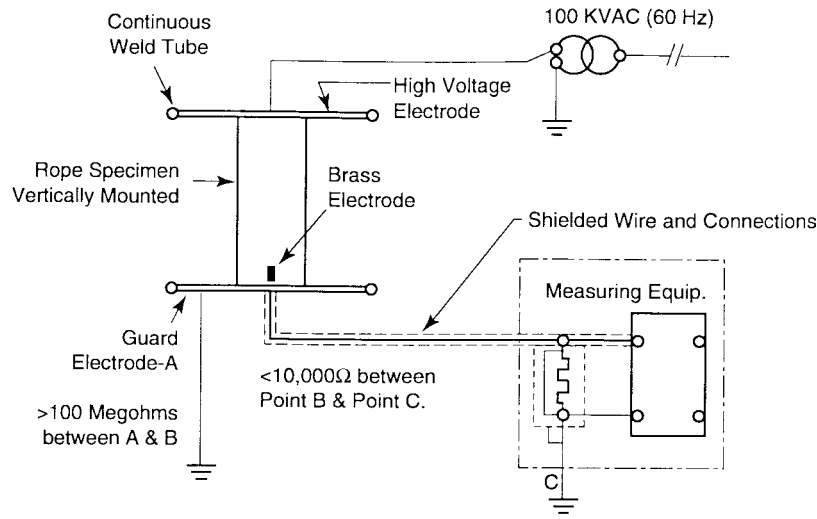

Typical A-C Test Set Up

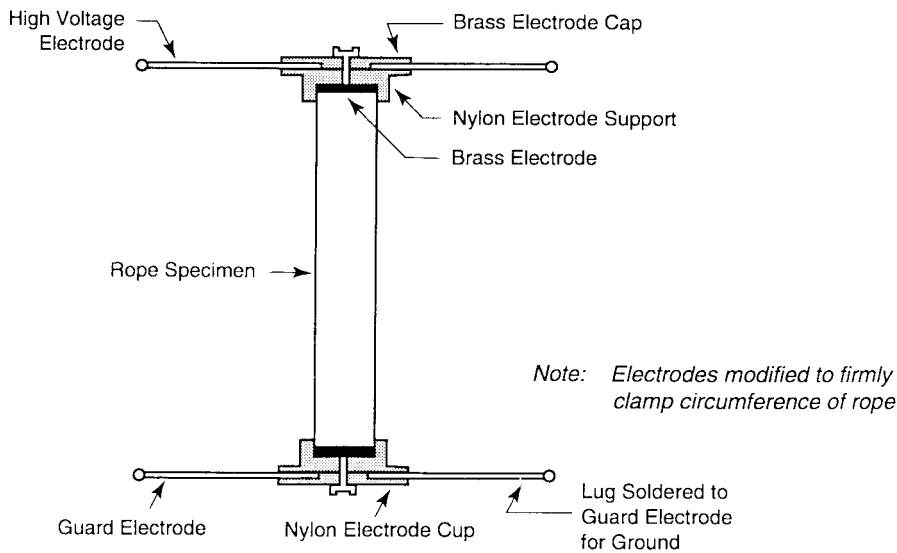

NOTE 1—Electrodes modified to firmly clamp circumference of rope.

FIG. 4 Test Configuration for Electrical Acceptance Tests

water used for wetting shall meet the requirements of IEEE Standard 4, that is,  $100 \Omega \text{ m}$  at ambient temperature  $\pm 15^\circ\text{C}$ . The resistivity may be measured by using the test methods as described in Test Methods D 1125.

13.5.6 *Drying of Specimen*—Within 1 min after removing specimen from wetting tank, the specimen shall be hung in a vertical position with an unrestrained weight of 4.5 kg (10 lb) attached and allowed to dry at as near standard atmospheric conditions as practical, with rope attachment point and weight attachment point as described in Fig. 2. The specimen shall be allowed to dry for 15 min.

13.5.7 *Wet Leakage Readings*—The 60 Hz voltage shall be raised from 1 to 50 kV rms in not less than 5 nor more than 15 s. The voltage shall be held at 50 kV rms for 5 min. If at the end of 5 min the current is not stable or exceeds  $100 \mu\text{A}$  or flashes

over, the specimen has failed.

13.6 *Mechanical/Physical Test Procedures:*

13.6.1 *Specimen for Test*—The specification for the test specimen is provided in the details for each mechanical/physical test.

13.6.2 *Mass per Unit Length*—The procedure for determining the mass per unit length shall be in accordance with Test Methods D 4268.

13.6.3 *Diameter and Circumference*—The method for determining the nominal circumference and diameter shall be in accordance with Test Methods D 4268.

13.6.4 *Hardness:*

13.6.4.1 Hardness shall be no less than 3b nor more than 15 lb.

13.6.4.2 Hardness shall be determined in accordance with

ASTM F 1701

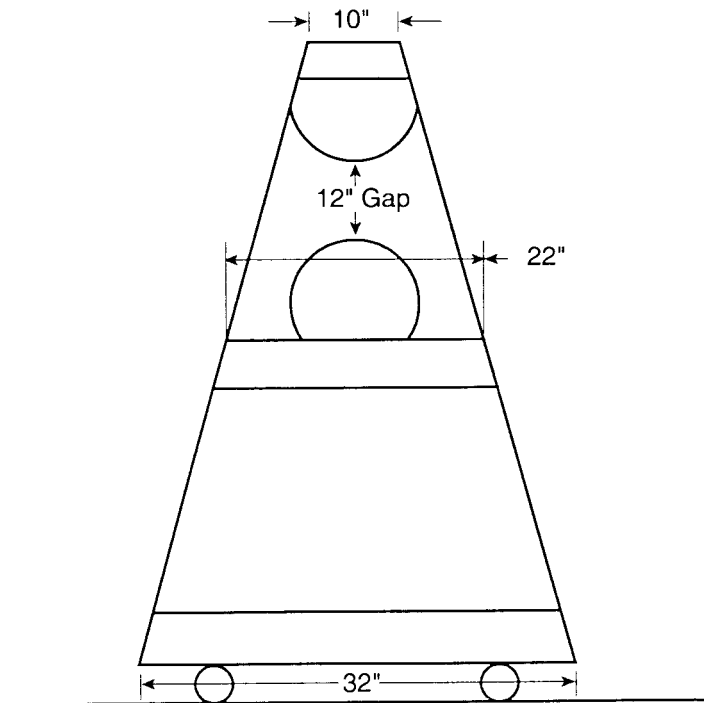
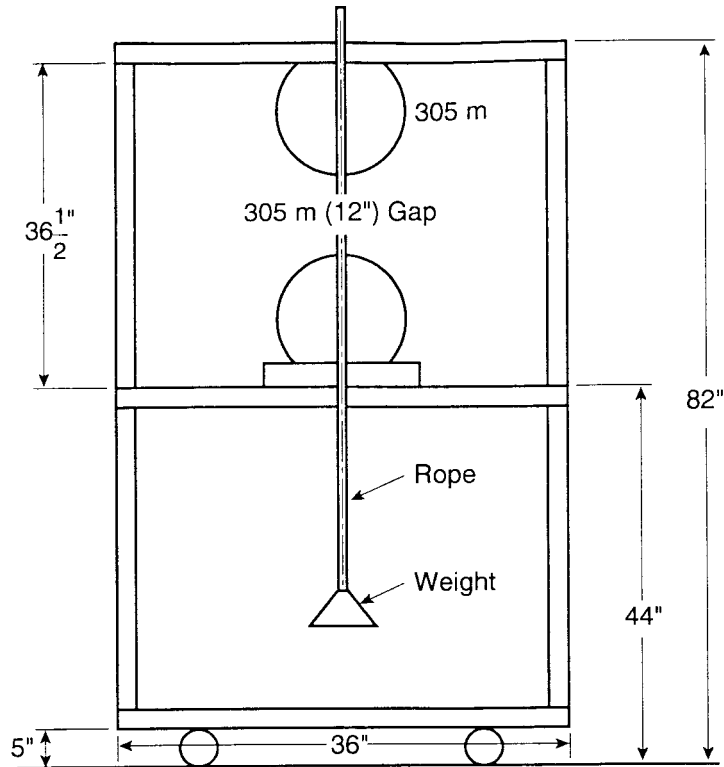

Alternate

FIG. 5 Alternative Test Configuration

Cordage Institute test methods.

13.6.5 Lay, Diameter, and Gage Length:

13.6.5.1 Lay and gage length shall be determined in accordance with ISO 2307. The diameter shall be determined in accordance with Test Methods D 4268.

13.6.5.2 Lay should be firm lay and right hand lay.

13.6.6 Breaking Strength—The method for determining the breaking strength of the rope shall be in accordance with Test Methods D 4268.

13.6.7 Elongation:



13.6.7.1 Elongation shall be determined in accordance with Test Methods D 4268.

13.6.7.2 This method covers the determination of elongation of new synthetic rope during its initial loading.

13.6.8 *Melt Point:*

13.6.8.1 An individual strand shall be placed on the plate of the melting point temperature tester with the temperature below the melting point. The temperature shall be increased until the part of the strand in contact with the plate contracts into a droplet. This temperature shall be recorded as the melting point. It shall be not less than 166°C.

13.6.8.2 This test is required for consistency of rope.

13.7 *Precision and Bias:*

13.7.1 Each testing agency has the responsibility of judging the acceptability of its own results. The precision of the results is a function of the procedures, facilities utilized, as well as compliance to the recommended industry state of the art practices. Reproducible analysis determinations by different users may be achieved only with identical facilities and trained conscientious personnel.

13.7.2 *Electrical Test Equipment:*

13.7.2.1 The test equipment shall be of such a quality that the applied voltage shall be within  $\pm 2\%$  of the specified test voltage.

13.7.2.2 The current-measuring device shall be of such a quality that the current measured shall be accurate to within  $\pm 2\%$  of scale reading.

13.7.3 Mechanical test equipment shall meet Practices E 4.

## 14. Inspection

14.1 Inspection of the material shall be agreed upon between the purchaser and the supplier as part of the purchase contract.

## 15. Rejection and Rehearing

15.1 Material that fails to conform to the requirements of this specification may be rejected. Rejection should be reported to the producer or supplier promptly and in writing. In case of dissatisfaction with the results of the test, the producer or supplier may make claim for a rehearing.

## 16. Certification

16.1 When specified in the purchase order or contract, the purchaser shall be furnished certification that samples representing each lot have been either tested or inspected as directed in this specification and the requirements have been met.

16.2 When specified in the purchase order or contract, a report of the test results shall be furnished.

## 17. Product Marking

17.1 A marker strip shall be used to identify the manufacturer and year of manufacture.

17.2 The marker strip shall be of the same chemical composition of the rope and shall not leach out any conductive substance when wet or dry.

## 18. Packaging and Package Marking

18.1 Exterior covering shall be furnished to prevent chafing or damage to rope during transit.

18.2 The manufacturer's packaging shall be acceptable unless specific request is made by the purchaser.

18.3 Each package shall be tagged or stencilled with weatherproof marking referencing this specification and, as a minimum, stating manufacturer's designation of rope, diameter, length, net and gross weight, manufacturer, and lot number.

*The American Society for Testing and Materials takes no position respecting the validity of any patent rights asserted in connection with any item mentioned in this standard. Users of this standard are expressly advised that determination of the validity of any such patent rights, and the risk of infringement of such rights, are entirely their own responsibility.*

*This standard is subject to revision at any time by the responsible technical committee and must be reviewed every five years and if not revised, either reapproved or withdrawn. Your comments are invited either for revision of this standard or for additional standards and should be addressed to ASTM Headquarters. Your comments will receive careful consideration at a meeting of the responsible technical committee, which you may attend. If you feel that your comments have not received a fair hearing you should make your views known to the ASTM Committee on Standards, at the address shown below.*

*This standard is copyrighted by ASTM, 100 Barr Harbor Drive, PO Box C700, West Conshohocken, PA 19428-2959, United States. Individual reprints (single or multiple copies) of this standard may be obtained by contacting ASTM at the above address or at 610-832-9585 (phone), 610-832-9555 (fax), or service@astm.org (e-mail); or through the ASTM website (www.astm.org).*