



Designation: F 1891 – 01a

Standard Specification for Arc and Flame Resistant Rainwear¹

This standard is issued under the fixed designation F 1891; the number immediately following the designation indicates the year of original adoption or, in the case of revision, the year of last revision. A number in parentheses indicates the year of last reapproval. A superscript epsilon (ϵ) indicates an editorial change since the last revision or reapproval.

1. Scope

1.1 This specification establishes applicable test methods, minimum physical and thermal performance criteria, a suggested sizing guide, and suggested purchasing information for rainwear for use by workers who may be exposed to thermal hazards of momentary electric arcs and open flames.

1.1.1 This specification does not apply to the electrical contact hazards or electric shock hazards involved with electric arcs.

1.1.2 This specification does not apply to flash fire hazards such as industrial hydrocarbon flash fires or other petrochemical flash fire hazards.

1.2 The objective of this specification is to prescribe fit, function and performance criteria for rainwear that meets a minimum level of thermal and physical performance when exposed to a laboratory-simulated electric arc or flame exposure.

1.3 This specification is not intended to serve as a detailed manufacturing or purchasing specification, but can be referenced in purchase contracts to ensure that minimum performance requirements are met.

1.4 Controlled laboratory tests used to determine compliance with the performance requirements of this specification shall not be deemed as establishing performance levels for all situations to which wearers of this protective clothing may be exposed.

1.5 The in-service care and use of this rainwear is beyond the scope of this specification.

1.6 The values stated in inch-pound units are to be regarded as the standard. The SI units shown in parentheses are for information only.

1.7 The following safety hazards caveat pertains only to Sections 7 and 9, of this specification: *This standard does not purport to address all of the safety concerns, if any, associated with its use. It is the responsibility of the user of this standard to establish appropriate safety and health practices and determine the applicability of regulatory limitations prior to use.*

2. Referenced Documents

2.1 ASTM Standards:

- D 123 Terminology Relating to Textiles²
- D 751 Test Methods for Coated Fabrics³
- D 1117 Guide for Evaluating Nonwoven Fabrics²
- D 1388 Test Method for Stiffness of Fabrics²
- D 3393 Specification for Coated Fabrics—Waterproofness³
- D 3776 Test Method for Mass Per Unit Area (Weight) of Fabric⁴
- F 1958 Test Method for Determining Ignitability of Non-Flame-Resistant Materials for Clothing by the Electric Arc Exposure Method Using Mannequins⁵
- F 1959/F 1959M Test Method for Determining the Arc Thermal Performance Value of Materials for Clothing⁵

2.2 Federal Specifications:

- Federal Test Method Standard (FTMS) No. 191A Method 5903.1⁶
- Federal Test Method Standard (FTMS) No. 191A Method 5516⁶
- Federal Test Method Standard (FTMS) No. CCC-T-191b Method 5204⁶

2.3 AATCC Standards:

- AATCC Test Method 135 Dimensional Changes Automatic Home Laundering of Woven and Knitted Fabrics⁷

3. Terminology

3.1 Definitions:

3.1.1 *afterflame time, n*—the length of time afterflame continues after the ignition source has been removed.

3.1.1.1 *Discussion—For arc testing*, the time begins when the arc current ceases and ends when visible flame ends.

3.1.2 *arc rating, n*—the maximum incident energy (E_1) resistance demonstrated by a material prior to breakopen or at the onset of a second degree burn.

3.1.2.1 *Discussion—*When the arc thermal performance value (ATPV) of the material cannot be determined due to

² Annual Book of ASTM Standards, Vol 07.01.

³ Annual Book of ASTM Standards, Vol 09.02.

⁴ Annual Book of ASTM Standards, Vol 07.02.

⁵ Annual Book of ASTM Standards, Vol 10.03.

⁶ Available from Standardization Documents Order Desk, Bldg. 4, Section D, 700 Robbins Ave., Philadelphia, PA 19111-5094, Attn: NPODS.

⁷ AATCC Technical Manual, available from American Association of Textile Chemists and Colorists, One Davis Dr., PO Box 12215, Research Triangle Park, NC 27709-2215.

¹ This specification is under the jurisdiction of ASTM Committee F18 on Electrical Protective Equipment for Workers and is the direct responsibility of Subcommittee F18.65 on Wearing Apparel.

Current edition approved Nov. 10, 2001. Published January 2002. Originally published as F 1891-98. Last previous edition F 1891-01.

breakopen, the arc rating is determined by measuring the breakopen threshold energy (E_{BT}) per Test Method F 1959/F 1959M. When the arc rating represents the arc thermal performance value, it is indicated as arc rating (ATPV); when representing the breakopen threshold energy, it is indicated as arc rating (E_{BT}).

3.1.3 *arc resistant, adj*—the property of a material or clothing system that provides thermal protection from an arc exposure.

3.1.4 *arc thermal performance value (ATPV), n—in arc testing*, the incident energy on a fabric or material that results in sufficient heat transfer through the fabric or material to cause the onset of a second-degree burn based on the Stoll curve.

3.1.5 *breakopen, n—in testing thermal protective materials*, a material response evidenced by the formation of one or more holes in the material which may allow flame to pass through the material.

3.1.5.1 *Discussion*—In electric arc testing, the specimen shall be considered to exhibit breakopen when any hole is at least $\frac{1}{2}$ in.² in area or at least 1 in. in any dimension.

3.1.6 *breakopen threshold energy (E_{BT}), n—in electric arc testing*, the average of the five highest E_i values that did not cause specimen breakopen and did not cause sensor temperature rise to exceed the Stoll Curve.

3.1.6.1 *Discussion*— E_{BT} is determined when ATPV and HAF cannot be determined due to breakopen.

3.1.7 *breakopen threshold energy above stoll (E_{BTAS}), n—in electric arc testing*, the average of the five highest E_i values which did not cause specimen breakopen regardless of whether sensor temperature rise exceeds the Stoll curve or not.

3.1.7.1 *Discussion*— E_{BTAS} is determined in addition to ATPV and HAF.

3.1.8 *char length, n—in measuring flame resistance of textiles*, the distance from the fabric edge which was directly exposed to the flame to the furthest point of visible fabric damage after a specified tearing force has been applied.

3.1.9 *charring, n*—the formation of carbonaceous residue as the result of pyrolysis or incomplete combustion.

3.1.10 *design test, n—for arc and flame resistant rainwear*, one made on a sample treated as representative of an industrial product; these tests will not generally be repeated in quantity production.

3.1.10.1 *Discussion*—Perform the design test only when a new or modified rainwear material, substrate, coating or adhesive is used to manufacture rainwear. A change in rainwear material could be, but is not limited to, any of the following: The composition, weight or supplier of the substrate, or both, coating, laminate, or adhesive.

3.1.11 *dripping, n—in testing thermal protective fabrics, coated fabrics or laminates*, a material response evidenced by flowing of the fiber polymer, the fabric, or the fabric coating, and the evidence of droplets from the material.

3.1.12 *electric arc ignition, n—as related to electric arc exposure*, a response that causes the ignition of textile material which is accompanied by heat and light, and then subsequent burning for at least 5 s, or consumption of at least 25 % of the test specimen area.

3.1.13 *embrittlement, n*—the formation of a brittle residue

as the result of pyrolysis or incomplete combustion.

3.1.14 *flame resistance, n*—the property of a material whereby flaming combustion is prevented, terminated, or inhibited following application of a flaming or nonflaming source of ignition, with or without subsequent removal of the ignition source.

3.1.15 *heat attenuation factor (HAF), n—in electric arc testing*, the percent of the incident energy which is blocked by a material at an incident energy level equal to ATPV.

3.1.16 *human tissue heat tolerance, n—in testing of thermal protective materials*, the amount of thermal energy transferred to human tissue, which is predicted to cause a second degree burn; the Stoll curve.

3.1.17 *incident energy (E_i), n—in electric arc testing*, the total heat energy received at a surface as a direct result of an electric arc.

3.1.17.1 *Discussion*—In an arc test, incident energy for a specimen is determined from the average temperature rise response of the two monitor sensors adjacent to the test specimen.

3.1.18 *melting, n*—the liquefaction of material under the influence of heat.

3.1.19 *shrinkage, n*—a decrease in one or more dimensions of an object or material.

3.1.19.1 *Discussion*—Shrinkage shall be determined as follows: before mounting the material specimen for arc exposure, measure the specimen width in inches (cm) at the mid point along the long dimension of the specimen. After arc exposure, measure the specimen width in inches (cm) at the point of greatest specimen shrinkage. The “shrinkage” in inches (cm) of the specimen is determined by subtracting the specimen width after arc exposure from the specimen width before arc exposure. The percent shrinkage is determined by dividing the “shrinkage” by the “specimen width” (before arc exposure) and multiplying by 100.

3.1.20 *stoll curve, n*—curve used to predict the onset of second degree burn injury.

3.1.20.1 *Discussion*—The values which make up the Stoll curve are listed in Table X5.1.

3.1.21 *thermal exposure, n*—the intensity of heat energy to which a fabric is exposed.

3.1.21.1 *Discussion*—As related to electric arc testing, the level of incident energy, in calories per centimetre squared (cal/cm^2), that is transferred to the material surface as determined by measuring the rise in temperature on monitor copper calorimeters, positioned adjacent to the material.

3.1.22 *thermal protection, n—of a material*, the property that characterizes overall performance relative to reducing the transfer of heat that is sufficient to cause a second-degree burn.

3.1.22.1 *Discussion*—Thermal protection of a material and the predicted second-degree burn injury can be quantified by the measured sensor response and the observed breakopen material response which indicate how well the material blocks heat from the sensor surface and how well the material resists breakopen.

3.1.23 *thermal resistance, n*—the reciprocal of thermal transmittance.



3.1.24 *thermal material response, n*—in the testing of thermal protective materials, the effects that are observed concurrent and subsequent to thermal exposure, which can include phenomena such as breakopen, charring, embrittlement, melting, shrinkage, etc.

3.1.24.1 *Discussion*—In electric arc testing, the thermal material response can be a result of intense radiant energy, convective energy, molten metal splatter from electrodes or shock wave from rapidly expanding heated, ionized air, or any combination of these.

3.1.25 *thermal transmittance, n*—time rate of unidirectional heat transfer per unit area, in the steady-state, between parallel planes separated by unit difference of temperature of the planes.

3.2 For definitions of other textile terms used in this specification refer to Terminology D 123.

4. Significance and Use

4.1 This specification covers the minimum performance criteria for arc resistance, flame resistance and other requirements for rainwear used by workers who may be exposed to thermal hazards of momentary electric arcs or flame.

4.1.1 Material response characteristics, resulting from the arc exposure shall be reported as a part of the thermal performance characteristics (see 9.3.4).

4.2 This specification establishes minimum performance criteria for rainwear material and rainwear seams that will provide workers with protection from rain under conditions of possible exposure to the thermal hazards of momentary electric arcs and open flames.

4.3 Rainwear material that meets the thermal and physical performance criteria of this specification has been subjected to an electric arc exposure test, Test Method F 1959/F 1959M.

NOTE 1—When rainwear is worn over conventional clothing or flame resistant garments, the rainwear material in combination with fabric(s) worn under the rainwear may also be subjected to the electric arc exposure test, Provisional Test Methods PS 57 or F 1959/F 1959M and the results reported.

4.4 The purchaser has the option to perform or have performed any of these tests in order to verify the performance of the rainwear. Claims for failure to meet the specification are subject to verification by the manufacturer.

4.5 This specification for rainwear shall not be construed as a requirement for the use of any particular rainwear material.

5. Ordering Information

5.1 The following items should be considered by the purchaser when buying rainwear under this specification and included, as necessary, in purchasing documents:

- 5.1.1 Type of material,
- 5.1.2 Fabric weight (oz/yd²),
- 5.1.3 Type and material of fasteners (buttons, snaps, zippers or hook and loop fasteners),
- 5.1.4 Reflective material sections (optional),
- 5.1.5 Style and design or catalog number,
- 5.1.6 Hood design (attached or detachable),
- 5.1.7 Sizes,
- 5.1.8 Color,
- 5.1.9 Special identification markings (optional),

5.1.10 Jacket length, and

5.1.11 Notation of conformance to this specification.

6. Materials and Manufacture

6.1 The rainwear shall be manufactured of materials and constructed using seams that meet the requirements for leak resistance.

6.2 Positive closures, such as buttons or snaps, should be constructed so that they are covered by the rainwear outer layer material. This will result in the garment having a multiple layer construction in the area of the closure. This will also prevent the positive closure from being directly exposed to the hazard.

NOTE 2—In limited testing, some uncovered closures may melt and fuse. Constructing the closures so that they are covered as described above eliminates the melting and fusing observed with uncovered closures.

7. Physical Requirements

7.1 Rainwear material shall meet the physical requirements of this specification initially as manufactured and shall meet this specification after five cleanings, when cleaned as directed by the care instructions from the manufacturer.

7.1.1 If no cleaning instructions are provided by the manufacturer, the garments shall be laundered five times in accordance with AATCC Method 135 (3, IV A iii).

7.1.2 The average weight of the rainwear material shall be determined in accordance with Test Method D 3776, Option C, using the following instructions: Five weight determination specimens, each consisting of a circle of material 3.5 in. (8.9 cm) in diameter, shall be taken from the sample of rainwear material which will be submitted for the material testing required in 7.2.1, 7.4.1, 9.2, and 9.3. If a single, continuous sample of rainwear material is used for all of the designated tests, one weight determination shall be done. If a different sample of rainwear material is used for one or more of the designated tests, a separate weight determination shall be done for each rainwear material sample. The five weight determination specimens shall be selected at approximately equally spaced intervals diagonally along the length of the rainwear material sample. For each weight determination that is done, the average weight for the five specimens and the weights of the individual specimens with the highest and lowest weights shall be reported to the testing laboratory. The supplier's nominal weight for the rainwear material shall also be reported to the testing laboratory.

7.2 *Leak Resistance—Fabric and Seams:*

7.2.1 The fabric of the sample rainwear shall withstand water pressure without leaking at 30 psig (207 kPa), when tested by Specification D 3393.

7.2.2 The seams of the sample rainwear material shall withstand water pressure with no evidence of water leakage at 3 psig (20.7 kPa) for 2 min, when tested by Federal Test Method Standard (FTMS) No. 191A Method 5516 as modified. (Note that this requirement is modified versus the parameters listed in the referenced test method.)

7.2.2.1 A pump device may be used to achieve 3 psig (20.7 kPa) if extension of the water column is not practical.

7.3 Markings and reflective materials attached to the rainwear shall be of the permanent type and electrically non-conductive, and shall not degrade the performance of the rainwear.

7.4 *Trapezoidal Tearing Resistance—Fabric:*

7.4.1 The rainwear material shall be tested for trapezoidal tearing resistance according to Test Methods D 1117 except that the measured value shall be the average of the five highest peak loads. Rainwear material shall have a trapezoidal tearing resistance of not less than 6 lb (2.7 kg) in the warp direction and 6 lb (2.7 kg) in the fill direction. Appendix X3 provides detailed information for the trapezoidal tearing resistance of rainwear material according to Test Methods D 1117.

8. Performance Requirements

8.1 Rainwear material shall conform to the requirements of 7.2.1 for leak resistance.

8.2 Rainwear shall be manufactured with seams that meet the criteria of 7.2.2 for leak resistance.

8.3 Markings and reflective materials shall conform to the requirements of 7.3.

8.4 Rainwear material shall conform to the requirements of 7.4 for trapezoidal tearing resistance.

8.5 The fabrics, stitchings, tapes, coatings, fasteners, and closures used to manufacture the rainwear should be made from electrically non-conductive materials. If conductive fasteners or closures, for example, zippers, snaps, or buttons, or combination thereof, are used, they shall be covered with a layer of rainwear material on the inside of the garment between the closure and the undergarment or skin.

8.5.1 *Discussion*—If fasteners or closures, for example, zippers, snaps, or buttons, or combination thereof, are used in a manner in which they are in contact with the skin, they can increase heat transfer and burn injury due to heat conduction to the skin. Using a layer of material between the conductive fastener or closure and the undergarment or skin can reduce heat transfer to the skin. There is no intent that this added layer of material can provide a reliable electrical insulation barrier.

8.6 The stitchings, thread, findings, zipper tapes, or fasteners, or combination thereof, used to manufacture the rainwear shall not degrade the flame resistance or thermal performance of the rainwear.

8.7 Rainwear material shall conform to the requirements of 9.2 for flame resistance.

8.8 Rainwear material shall conform to the requirements of 9.3 for thermal resistance to an electric arc exposure.

9. Thermal Performance Requirements

9.1 If the rainwear is constructed of a single-layer fabric or a multi-layer fabric, then a single- or multi-layer sample of the rainwear as constructed shall be subjected to all thermal tests.

9.2 The rainwear fabric shall be tested for flame resistance by use of Federal Test Method Standard (FTMS) No. 191A Method 5903.1, Flame Resistance Cloth Vertical. Specimens shall not melt and drip when subjected to the flame or continue to burn for more than 2 s after removal of the ignition source. The char length shall be less than 6 in. (15 cm) for each specimen.

NOTE 3—Both melting and dripping must occur for a specimen to fail.

An indication of melting by itself shall not be interpreted as melting and dripping.

9.2.1 Rainwear material shall meet the requirements of 9.2 initially as manufactured and after five cleanings when cleaned as directed by care instructions from the manufacturer.

9.2.1.1 If no cleaning instructions are provided by the manufacturer, the garments shall be laundered three times in accordance with AATCC Method 135 (3, IV A iii).

9.3 Rainwear fabric shall be tested for thermal resistance to an electric arc exposure by the use of Test Method F 1959/F 1959M. Test parameters for Test Method F 1959/F 1959M shall be 8 ± 1 kA arc current, 12 in. electrode gap, stainless steel electrodes, 12 in. distance between the arc center line and the rainwear material specimen surface. Additional test parameters may also be used and the results reported on an optional basis.

NOTE 4—Test Method F 1959/F 1959M is a design test.

9.3.1 Rainwear material shall be tested in accordance with 9.3 after three washings followed by one drying. The washing shall be done as directed by care instructions from the manufacturer.

9.3.1.1 If no cleaning instructions are provided by the manufacturer, the garments shall be washed three times in accordance with the AATCC Method 135 (3, IV A iii) followed by one drying.

9.3.2 When rainwear is subjected to higher arc current exposures, the arc rating (ATPV) increases due to surface cooling effects or rainwear material changes, or both, during arc exposure. Consequently, Test Method F 1959/F 1959M arc test parameters are mandated in order to provide a consistent comparative database for rainwear fabrics. The specific parameter of 8 kA was selected due to ATPV changes leveling off close to a minimum value at this arc current level and due to relatively high availability of rainwear results at this arc current level.

9.3.3 The arc rating (ATPV) or arc rating (E_{BT}), heat attenuation factor (HAF) shall be determined according to Test Method F 1959/F 1959M and reported.

NOTE 5—The determination of E_{BTAS} is not discussed in Test Method F 1959/F 1959M. See 3.1.6 and Appendix X4 for information and examples on how to determine E_{BTAS} using the Test Method F 1959/F 1959M test method procedure. Determination of E_{BTAS} may require additional arc exposures at higher incident energy in order to reach the breakopen threshold energy level.

NOTE 6— E_{BTAS} is a term meant to be used to aid end users in matching rainwear to the appropriate protective ensemble. That is to say, after the electrical arc hazard's E_i has been quantified in terms of cal/cm^2 , the next step is to select a protective ensemble with an ATPV rating, quantified in terms of cal/cm^2 , that is equal to or greater than the electrical arc hazard's E_i . At this point rainwear to be worn as an outer layer can be matched to the subject ensemble by ensuring that the E_{BTAS} of the rainwear is equal to or greater than the ATPV rating for the ensemble it is to be placed over. If rainwear is to be relied on as one of the protective layers in a protective ensemble, then it needs to be tested as a multi-layer ensemble in accordance with Test Method F 1959/F 1959M and assigned an ATPV rating, which in turn has to be equal to or greater than the hazard in question. In other words, the E_{BTAS} is not to be used as a protective term in matching rainwear to a hazard, but rather is a breakopen term to be used to match rainwear to the protective ensemble that has already been appropriately matched with the hazard in question. It should be noted that

rainwear may pose a hazard to the wearer if it is exposed to energy beyond E_{BTAS} regardless of the presence of protective underlayers.

NOTE 7— E_{BTAS} is determined because it is important to report a breakopen threshold for rainwear material, since melting and ignition hazards may occur when a rainwear material breaks open during arc exposure.

9.3.3.1 When ATPV and HAF cannot be determined due to fabric breakopen, the breakopen threshold energy E_{BT} shall be determined according to Test Method F 1959/F 1959M and reported.

9.3.4 Breakopen threshold energy (E_{BT}) or breakopen threshold energy above stoll (E_{BTAS}) shall be equal to or greater than 5.0 cal/cm^2 .

9.3.5 The material response characteristics for rainwear material, including *afterflame time, breakopen, charring, electric arc ignition, embrittlement, melting, and shrinkage*, shall be reported for two typical exposures at least equal to the arc rating (ATPV) or arc rating (E_{BT}) value and also for two typical exposures at least two times the arc rating (ATPV) or arc rating (E_{BT}) value. Material response for dripping shall be reported for two typical exposures at least two times the arc rating (ATPV) or arc rating (E_{BT}) value.

9.3.6 When arc testing according to Test Method F 1959/F 1959M, dripping shall be determined by observing all valid arc test specimen exposures in an incident energy range from zero to 2 cal/cm^2 above the arc rating (ATPV) or arc rating (E_{BT}) (whichever is applicable). At least three arc test specimen exposures for which the incident energy is at least equal to the arc rating (ATPV) or arc rating (E_{BT}) but not greater than 2.0 cal/cm^2 above the arc rating (ATPV) or arc rating (E_{BT}) shall be used in the determination of dripping. There shall be no dripping for valid arc test specimen exposures within this range of incident energy.

9.3.6.1 An arc test specimen exposure involves a single test specimen on one instrumented panel in Test Method F 1959/F 1959M. A valid arc test specimen exposure is one which can be used in the determination of arc rating (ATPV) or arc rating (E_{BT}) according to Test Method F 1959/F 1959M, for example, in the case of arc rating (ATPV) specimen exposures that do not exhibit breakopen, and in the case of arc rating (E_{BT}) specimen exposures that do not exhibit breakopen and do not exceed the Stoll curve. Both melting and dripping must occur for a specimen to fail.

9.3.6.2 Specimen exposures for the determination of dripping shall all be from the same lot of test material.

9.3.6.3 Specimen exposures for the determination of dripping shall be from the same arc testing series and shall be conducted on a single day or consecutive testing days.

9.3.7 There shall be no dripping for the specimen exposures at least two times the arc rating (ATPV) or the arc rating (E_{BT}).

10. Stiffness of Rainwear Fabrics (Optional Test Method)

10.1 Optional test methods for determining stiffness of the rainwear are provided in Appendix X2.

11. Sequence of Testing and Inspection

11.1 The following order of testing is suggested for the evaluation of rainwear material:

11.1.1 Inspection of the fabric and seam specimen.

11.1.2 Water leakage testing; fabric and prepared seam specimen.

11.1.3 Fabric trapezoidal tearing resistance testing.

11.1.4 Fabric flame resistance testing.

11.1.5 Electric arc exposure testing. (This is a design test.)

11.1.6 Inspection of rainwear, seams, style, labeling, markings and color.

12. Compliance Certification

12.1 Rainwear material shall be tested and certified by the manufacturer or supplier to be in compliance with the requirements of this specification.

12.1.1 The user, at his expense, shall have the option to verify compliance with the requirements of this specification.

12.2 Except where noted as a design test, the rainwear material shall be tested at least every 12 months to confirm compliance with the requirements of this specification.

12.3 The rainwear supplier or manufacturer shall provide compliance testing and certification to the purchaser when a new or modified rainwear material, substrate, coating, or adhesive is used to manufacture rainwear. A change in rainwear material could be, but is not limited to, any of the following: the composition, weight, or supplier of the substrate, coating, laminate, or adhesive, or combination thereof. The test noted as “design test” as well as all other tests shall be repeated to verify compliance with the performance requirements of this specification.

12.4 The entire shipment or lot of rainwear material shall be rejected for use under this specification if the selected samples do not meet the requirements of this specification.

13. Labeling, Identification, and Packaging

13.1 Each item of rainwear shall be permanently identified or labeled with its size, style designation or catalog number, the manufacturer’s name and notation of conformance to this specification. These shall be indelibly marked such as with an embroidered label or equivalent permanently affixed to the inside of the rainwear at the top of the back of each item of rainwear or at the bottom hem of each item of rainwear.

13.2 The supplier shall provide an indelibly marked label such as an embroidered label or equivalent designating the arc rating as either the arc rating (ATPV) or arc rating (E_{BT}) of the base fabric used to manufacture the item and affixed in a readily visible location inside of each item of rainwear.

13.3 A care label shall provide instructions for cleaning and shall be attached so that it will remain firmly attached and readable throughout the life of the rainwear.

13.4 The method of packaging individual or bulk, shall be agreed to between the supplier and purchaser.

13.4.1 Each rainsuit or item of rainwear should be individually packaged.

13.4.2 The following information shall be provided on or in the package: name of manufacturer, size, fabric material, catalog number or style of the contents, date code or date of manufacture of the rainwear, and the ASTM designation.

14. Sizing

14.1 An optional sizing guide is provided in Appendix X1. Sizes shall be agreed upon between the rainwear manufacturer and the purchaser.

15. Keywords

15.1 arc thermal performance value; breakopen threshold energy; electric arc; electric arc ignition; flame resistant; heat attenuation factor; incident energy; leak resistant; thermal hazard

APPENDIXES

(Nonmandatory Information)

X1. SIZING AND MEASUREMENTS

X1.1 Sizing Guide

X1.1.1 When placed without tension on a flat surface so that the rainwear is without creases or wrinkles, and measured at the points indicated, the rainwear shall conform to the measurements shown in Table X1.1.

X1.2 Measurements

X1.2.1 *Jacket Measurements*—See Fig. X1.1.

X1.2.1.1 *Chest Girth (C)*—Twice the distance across the closed rainwear jacket measured 1 in. (2.5 cm) below the lowest points of the armhole seams. Location of the armhole seams can be approximated for designs without arm hole seams, for example, batwing designs.

X1.2.1.2 *Sleeve Length (A)*—The distance from the vertical centerline of the jacket at the base of the collar band or hood attachment seam to the end of the sleeve.

X1.2.1.3 *Sleeve at Elbow Girth (E)*—Twice the distance across the sleeve at a point midway along the underarm length of the sleeve.

X1.2.1.4 *Jacket Length (L)*—The distance from the base of the collar band or hood attachment seam at the vertical centerline of the jacket to the bottom of the jacket shall be 30 in. (75 cm) as standard. Optional lengths may be specified upon agreement between the manufacturer and purchaser.

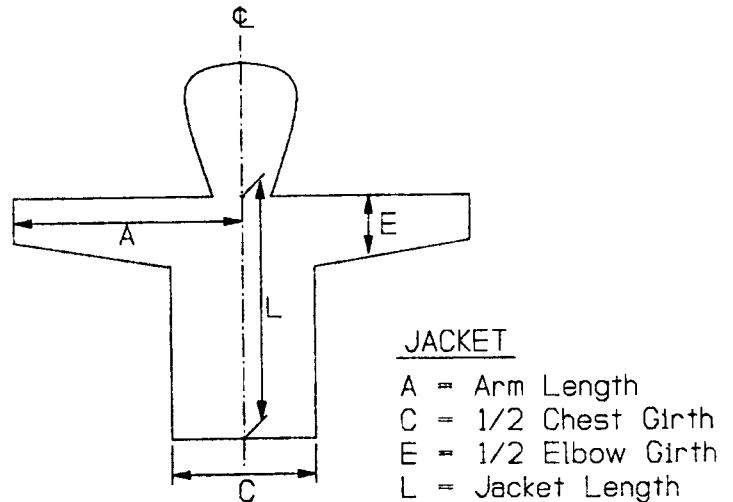

FIG. X1.1 Jacket Measurements

X1.2.2 *Trousers Measurements*—See Fig. X1.2.

X1.2.2.1 *Waist Girth (W)*—Twice the distance across the waist at a distance of 8 in. (20 cm) above the crotch for trousers with bib front and suspenders.

X1.2.2.2 *Knee Girth (K)*—Twice the distance across the leg at a position midway between the crotch and the bottom of the leg.

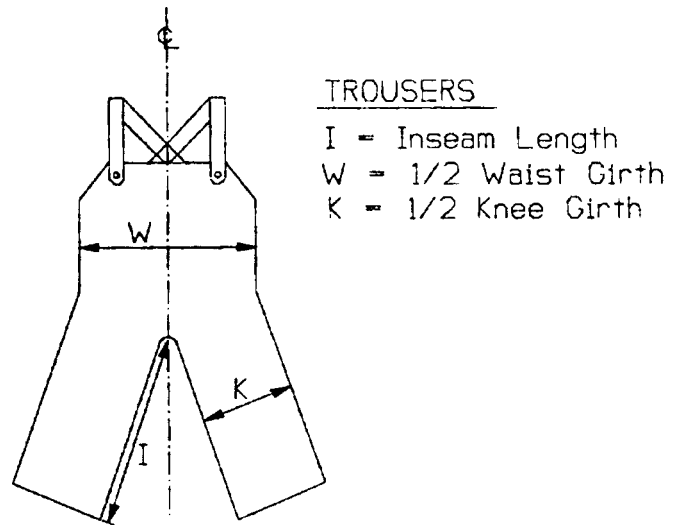

FIG. X1.2 Trousers Measurements

TABLE X1.1 Two Piece Rainsuit Measurements

Jacket—Measurements in Inches (Centimetres)			
Size	Chest Girth (C)	Sleeve Length (A)—See Note X1.1	Sleeve at Elbow Girth (E)
Small	45 (114)	32 (81)	19 (48)
Medium	49 (124)	33 (84)	19 (48)
Large	53 (135)	34 (86)	19 (48)
X-Large	57 (145)	35 (89)	20 (51)
XX-Large	60 (152)	36 (91)	20 (51)
XXX-Large	64 (163)	36 (91)	20 (51)
Trousers—Measurements in Inches (Centimetres)			
Size	Waist Girth (W)	Leg Inseam Length (I)—See Note X1.1	Knee Girth (K)
Small	42 (107)	29 (74)	21 (53)
Medium	45 (114)	30 (76)	22 (56)
Large	48 (122)	31 (78)	23 (58)
X-Large	51 (130)	31 (78)	24 (61)
XX-Large	54 (137)	32 (81)	25 (64)
XXX-Large	57 (145)	32 (81)	26 (66)

X1.2.2.3 *Leg Inseam (I)*— The distance from the crotch along the leg seam to the bottom edge of the leg.

X1.3 Permissible Measurement Tolerances

X1.3.1 *Girth Measurements*—Table X1.1 value ± 1 in. (± 2.5 cm).

X1.3.2 *Length Measurements*—Table X1.1 value ± 0.6 in. (± 1.5 cm).

NOTE X1.1—Table X1.1 provides measurements for regular length rainsuits. Short and tall sizes may be provided by changing the sleeve and

leg lengths of the regular length measurements. Short sizes should have 2 in. (5 cm) subtracted from the sleeve and leg lengths listed in Table X1.1. Tall sizes should have 2 in. (5 cm) added to the sleeve length and leg lengths as listed in Table X1.1. Girth measurements for short and tall heights should conform to Table X1.1 measurements. Additional special sizes may be agreed to between user and manufacturer.

X1.4 Measurement of Fabric Thickness and Mass (Optional)

X1.4.1 Fabric thickness and mass shall be determined by the procedure included in Test Methods D 751.

X2. DRAPE STIFFNESS

X2.1 Perform the drape stiffness test in a manner similar to the method specified in Test Method D 1388. Use Option A, Cantilever Test, of Test Method D 1388 as the test method. Drape stiffness is a measure of how a material will bend under its own weight, and is referred to as “bending length” in Test Method D 1388.

X2.1.1 A 1 by 6 in. (25 by 150 mm) rectangular specimen may be used for testing typical rainwear fabrics.

X2.1.2 Test five specimens from each sample lot. The test may be performed over a range of temperatures between $10 \pm$

4°F ($-12 \pm 2^{\circ}\text{C}$) and $110 \pm 4^{\circ}\text{F}$ ($43 \pm 2^{\circ}\text{C}$). Condition the specimen and the test device for at least 4 h at each of these temperatures prior to the performance of the test. The test shall be conducted at the same temperature used to condition the fabric specimens.

X2.2 An alternate test method, Federal Test Method Standard (FTMS) No. CCC-T-191b Method 5204, the Clark Stiffness Tester, may also be used to determine flexural rigidity.

X3. TRAPEZOIDAL TEARING RESISTANCE

X3.1 Test Methods D 1117, trapezoidal tearing resistance test information for testing rainwear material, is provided as general assistance and clarification to the test laboratory.

X3.1.1 The specimen shall be a 3×6 in. (76.2×152.4 mm) rectangle. The long dimension shall be parallel to the warp for warp tests and parallel to the filling for filling tests. No two specimens for warp tests shall contain the same filling yarns. The specimen shall be taken to avoid the selvage of the cloth. An isosceles trapezoid having an altitude of 3 in. (76.2 mm) and bases of 1 and 4 in. (25.4 and 101.6 mm) in length, respectively, shall be marked on each specimen with the aid of a template. A cut $\frac{3}{8}$ in. (9.5 mm) in length shall then be made in the center of a line perpendicular to the 1 in. (25.4 mm) edge.

X3.1.2 Apparatus shall consist of a straining mechanism, two clamps for holding specimens, and load and elongation recording mechanisms, wherein the specimen is held between two clamps and strained by a uniform movement of the pulling clamp. The test machine shall be operated at a rate of 12 in./min (304.8 mm/min). The apparatus shall be constant-rate-of-extension (CRE) device.

X3.1.2.1 Straining mechanism shall be of such capacity that the maximum load required to break the specimen shall be not greater than 85 % or less than 15 % of the rated capacity of the straining mechanism as specified by the manufacturer.

X3.1.2.2 Clamps shall be designed such that the 6 oz (170 g) of weight are distributed evenly across the complete width of the sample. The clamps shall have two jaws on each clamp. The design of the clamps shall be such that one gripping

surface or jaw shall be permitted to be an integral part of the rigid frame of the clamp or be fastened to allow a slight vertical movement, while the other gripping surface or jaw shall be completely moveable. The dimensions of the immovable jaw of each clamp parallel to the application of the load shall measure 1 in. (25.4 mm), and the dimension of the jaw perpendicular to this direction shall measure 3 in. (76.2 mm) or more. The face of the moveable jaw of each clamp shall measure 1×3 in. (25.4×76.2 mm). Each jaw face shall have a flat, smooth gripping surface. All edges that might cause a cutting action shall be rounded to a radius of not more than $\frac{1}{64}$ in. (0.4 mm). In cases where a cloth tends to slip when being tested, the jaws shall be faced with rubber or other material to prevent slippage. The distance between the jaws shall be 1 in. (25.4 mm) at the start of the test.

X3.1.2.3 Recorder shall consist of a calibrated dial, scale, or chart used to indicate applied load and elongation. Error shall not exceed 2 % up to and including a 50-lb (22.7-kg) load and 1 % over a 50-lb (22.7-kg) load at any reading within its loading range. All machine attachments for determining maximum loads shall be disengaged during the test.

X3.1.3 The specimen shall be clamped along the nonparallel sides of the trapezoid so that these sides lie along the lower edge of the upper clamp and upper edge of the lower clamp with the cut halfway between the clamps. The short trapezoid base shall be held taut, and the long trapezoid base shall lie in the folds. The strain mechanism shall be started, and the force necessary to tear the cloth shall be observed by means of the recording device. Five specimens in each of the warp and

filling directions shall be tested from each sample unit. If a specimen slips between the jaws, breaks in or at the edges of the jaws, or, if for any reason attributable to faulty technique, an individual measurement falls markedly below the average test results for the sample unit, such result shall be discarded and another specimen shall be tested.

X3.1.4 The trapezoidal tearing resistance shall be the average of the five highest peak loads of resistance registered. The tear strength shall be reported to the nearest 0.1 lb (45.4 g). The standard deviation shall also be determined and reported.

X4. RAINWEAR TESTING GUIDANCE

X4.1 Examples of ATPV, E_{BT} and E_{BTAS} are provided for clarification of 9.3. The listed values are typical of actual rainwear tests.

X4.1.1 *Example 1*—ATPV and HAF are measured using Test Method F 1959/F 1959M to be 4.0 cal/cm² and 50.5 %, respectively, based on temperature rise data from 20 exposed specimens, which did not breakopen. The breakopen threshold energy above stall, E_{BTAS} , is determined to confirm that breakopen (3.1.4) occurs above the minimum of 5 cal/cm² as required in 9.3.4. Arc testing is continued at higher exposure levels to determine E_{BTAS} . The duration of the arc exposure is increased in order to reach the breakopen threshold energy so that E_{BTAS} can be determined. Breakopen as defined in 3.1.4 is observed above 9.5 cal/cm². The highest five incident energy values that did not cause breakopen (7.9, 8.4, 9.1, 9.3, 9.4 cal/cm²) are averaged to determine E_{BTAS} (per 3.1.6) to be 8.8 cal/cm². Material response characteristics are reported below for two typical exposures at least equal to ATPV (4.1 and 4.3 cal/cm²) and for two exposures at least two times the ATPV (8.4 and 9.1 cal/cm²).

X4.1.1.1 Reported results and material response characteristics for Rainwear Material X:

Sample X:	ATPV (cal/cm ²)	4.0			
	HAF (%)	50.5			
	E_{BTAS} (cal/cm ²)	8.8			
Compliance Based on Testing Results		Yes	$(E_{BTAS} > 5 \text{ cal/cm}^2)$		
Material Response Characteristics:					
Electric Arc Shot No.	96-0751	96-0750	96-0755	96-0758	
Panel Location	A	B	C	C	
Incident Energy (cal/cm ²)	4.1	4.3	8.4	9.1	
Afterflame time (s)	1	0	4	6	
Breakopen (in.)	No	No	No	No	
Charring ^A	None	Slight	Moderate	Moderate	
Melting ^A	None	None	Slight	Moderate	
Dripping ^A	None	None	None	None	
Electric Arc Ignition	No	No	No	Yes	
Embrittlement ^A	None	None	Moderate	Severe	
Shrinkage, %	0	5	10	14	

^A Suggested rating system—None, slight, moderate, severe. It is recommended

that the testing laboratory establish appropriate reference standards for these material response characteristics.

X4.1.2 *Example 2*—ATPV and HAF are measured using Test Method F 1959/F 1959M to be 4.0 cal/cm² and 50.5 %, respectively, and E_{BTAS} is determined to be 4.5 cal/cm². Since E_{BTAS} is less than 5.0 cal/cm², this rainwear material is not in compliance per 9.3.4.

X4.1.3 *Example 3*—ATPV and HAF cannot be determined due to breakopen, so E_{BT} is determined according to Test Method F 1959/F 1959M as the average of the highest five incident energy values which did not cause breakopen (3.1.4). The E_{BT} is calculated from the following incident energy values 6.1, 6.8, 7.1, 7.3, 7.7 cal/cm² to be 7.0 cal/cm². Arc testing is continued at higher exposure levels of approximately 15 cal/cm² to obtain information in 9.3.5. The material responses characteristics are reported for two typical exposures at least equal to the E_{BT} value and for two exposures at least equal to two times the E_{BT} value (14.3 and 15.2 cal/cm²).

X4.1.3.1 Reported results and subjective material thermal responses for Rainwear Material Y:

Sample Y:	ATPV (cal/cm ²)	Not Available			
	HAF (%)	Not Available			
	E_{BT} (cal/cm ²)	7.0			
Compliance Based on Testing Results		Yes	$(E_{BT} > 5 \text{ cal/cm}^2)$		
Subjective Material Thermal Responses					
Electric Arc Shot No.	97-0077	97-0072	97-0081	97-0083	
Panel Location	B	C	A	B	
Incident Energy (cal/cm ²)	7.1	7.3	14.3	15.2	
Afterflame time (s)	1	0	4	6	
Breakopen (in.)	No	No	1 × 4	2 × 6	
Charring ^A	None	Slight	Moderate	Severe	
Melting ^A	None	None	Slight	Slight	
Dripping ^A	None	None	None	None	
Electric Arc Ignition	No	No	No	Yes	
Embrittlement ^A	None	None	Moderate	Severe	
Shrinkage, %	0	5	10	14	

^A Suggested rating system—None, slight, moderate, severe. It is recommended that the testing laboratory establish appropriate reference standards for these material response characteristics.

X5. HUMAN TISSUE TOLERANCE TO HEAT—SECOND-DEGREE BURN
TABLE X5.1 Human Tissue Tolerance to Heat—Second-Degree Burn^A

Exposure Time, s	Heat Flux		Total Heat		Calorimeter ^B Equivalent		
	kW/m ²	cal/cm ² s	kWs/m ²	cal/cm ²	ΔT°C	ΔT°F	ΔmV
1	50	1.2	50	1.20	8.9	16.0	0.46
2	31	0.73	61	1.46	10.8	19.5	0.57
3	23	0.55	69	1.65	12.2	22.0	0.63
4	19	0.45	75	1.80	13.3	24.0	0.69
5	16	0.38	80	1.90	14.1	25.3	0.72
6	14	0.34	85	2.04	15.1	27.2	0.78
7	13	0.30	88	2.10	15.5	28.0	0.80
8	11.5	0.274	92	2.19	16.2	29.2	0.83
9	10.6	0.252	95	2.27	16.8	30.2	0.86
10	9.8	0.233	98	2.33	17.3	31.1	0.89
11	9.2	0.219	101	2.41	17.8	32.1	0.92
12	8.6	0.205	103	2.46	18.2	32.8	0.94
13	8.1	0.194	106	2.52	18.7	33.6	0.97
14	7.7	0.184	108	2.58	19.1	34.3	0.99
15	7.4	0.177	111	2.66	19.7	35.4	1.02
16	7.0	0.168	113	2.69	19.8	35.8	1.03
17	6.7	0.160	114	2.72	20.2	36.3	1.04
18	6.4	0.154	116	2.77	20.6	37.0	1.06
19	6.2	0.148	118	2.81	20.8	37.5	1.08
20	6.0	0.143	120	2.86	21.2	38.1	1.10
25	5.1	0.122	128	3.05	22.6	40.7	1.17
30	4.5	0.107	134	3.21	23.8	42.8	1.23

^A Derived from: Stoll, A. M., and Chianta, M. A., "Method and Rating System for Evaluations of Thermal Protection," *Aerospace Medicine*, Vol 40, 1969, pp 1232–1238, and Stoll, A. M., and Chianta, M. A., "Heat Transfer through Fabrics as Related to Thermal Injury," *Transactions—New York Academy of Sciences*, Vol 33 (7) November 1971, pp 649–670.

^B Iron/constantan thermocouple.

ASTM International takes no position respecting the validity of any patent rights asserted in connection with any item mentioned in this standard. Users of this standard are expressly advised that determination of the validity of any such patent rights, and the risk of infringement of such rights, are entirely their own responsibility.

This standard is subject to revision at any time by the responsible technical committee and must be reviewed every five years and if not revised, either reapproved or withdrawn. Your comments are invited either for revision of this standard or for additional standards and should be addressed to ASTM International Headquarters. Your comments will receive careful consideration at a meeting of the responsible technical committee, which you may attend. If you feel that your comments have not received a fair hearing you should make your views known to the ASTM Committee on Standards, at the address shown below.

This standard is copyrighted by ASTM International, 100 Barr Harbor Drive, PO Box C700, West Conshohocken, PA 19428-2959, United States. Individual reprints (single or multiple copies) of this standard may be obtained by contacting ASTM at the above address or at 610-832-9585 (phone), 610-832-9555 (fax), or service@astm.org (e-mail); or through the ASTM website (www.astm.org).