



Designation: F 914 – 9803

# Standard Test Method for Acoustic Emission for Insulated and Non-Insulated Aerial Personnel Devices Without Supplemental Load Handling Attachments<sup>1</sup>

This standard is issued under the fixed designation F 914; the number immediately following the designation indicates the year of original adoption or, in the case of revision, the year of last revision. A number in parentheses indicates the year of last reapproval. A superscript epsilon ( $\epsilon$ ) indicates an editorial change since the last revision or reapproval.

## 1. Scope

1.1 This test method ~~covers~~ describes a procedure for non-destructive testing using acoustic emission (AE) testing ~~of~~ for insulated and non-insulated aerial personnel devices which do not have a supplemental load handling attachment.

1.1.1 *Equipment Covered*—This test method covers the following types of vehicle-mounted insulated aerial personnel devices:

1.1.1.1 Extensible boom aerial personnel devices,

1.1.1.2 Articulating boom aerial personnel devices, and

1.1.1.3 Any combination of 1.1.1.1 and 1.1.1.2.

1.1.2 *Equipment Not Covered*—This test method does not cover any of the following equipment:

~~1.1.2.1 Noninsulated~~

~~1.1.2.1 Material-handling aerial devices,~~

~~1.1.2.2 Material-handling aerial devices,~~

~~1.1.2.3 Digger-derricks~~

~~1.1.2.2 Digger-derricks with platform, and~~

~~1.1.2.4~~ Cranes with platform.

1.2 The AE test method is used to detect and area-locate emission sources. Verification of emission sources may require the use of other nondestructive test (NDT) methods, such as radiography, ultrasonics, magnetic particle, liquid penetrant, and visual inspection. **Warning**—This test method requires that external loads be applied to the superstructure of the vehicle under test. During the test, caution must be taken to safeguard personnel and equipment against unexpected failure or instability of the vehicle or components.

NOTE 1—This test method is not intended to be a stand alone NDT method for the verification of the structural integrity of an aerial device. Other NDT methods should be used to supplement the results.

1.3 The values given in inch-pound units are to be regarded as the standard. The SI units given in parentheses are for information only.

1.4 *This standard does not purport to address all of the safety concerns, if any, associated with its use. It is the responsibility of the user of this standard to establish appropriate safety and health practices and determine the applicability of regulatory limitations prior to use.*

## 2. Referenced Documents

2.1 *ASTM Standards:*

E 569 Practice for Acoustic Emission Monitoring of Structures During Controlled Stimulation<sup>2</sup>

<sup>1</sup> This test method is under the jurisdiction of ASTM Committee F18 on Electrical Protective Equipment for Workers and is the direct responsibility of Subcommittee F18.55 on Acoustic Emission.

Current edition approved November 10, 1998; 2003. Published February 1999; November 2003. Originally published as F 914—85; approved in 1985. Last previous edition approved in 1998 as F 914 – 978.

E 610 Terminology Relating to Acoustic Emission<sup>3</sup>

E 650 Guide for Mounting Piezoelectric Acoustic Emission Sensors<sup>2</sup>

E 750 Practice for Characterizing Acoustic Emission Instrumentation<sup>2</sup>

E 976 Guide for Determining the Reproducibility of Acoustic Emission Sensor Response<sup>2</sup>

F 2174 Practice for Verifying Acoustic Emission Sensor Response<sup>4</sup>

2.2 *ANSI Standard:*

ANSI A92.2 Standard for Vehicle-Mounted Elevating and Rotating Aerial Devices<sup>5</sup>

2.3 *ASNT Standard:*

ASNT Recommended Practice SNT-TC-1A<sup>6</sup>

2.4 *CARP/SPI Standard:*

Recommended Practice for Acoustic Emission Testing of Fiberglass Tanks-Vessels<sup>6</sup>

---

<sup>2</sup> *Annual Book of ASTM Standards*, Vol 03.03.

<sup>3</sup> Discontinued; see *1991 Annual Book of ASTM Standards*, Vol 03.03. Replaced by Terminology E 1316.

<sup>4</sup> ~~Available from the American National~~

<sup>4</sup> ~~*Annual Book of ASTM Standards Institute, 11 West 42nd St., 13th Floor, New York, NY 10036*, Vol 10.03.~~

<sup>5</sup> ~~Available from the American Society of Nondestructive Testing, 4153 Arlingate Plaza, Caller #28518, Columbus, OH 43228; National Standards Institute, 11 West 42nd St., 13th Floor, New York, NY 10036.~~

<sup>6</sup> ~~Available from the American Society of Plastics Industry, 355 Lexington Ave., New York, NY 10017; Nondestructive Testing, 4153 Arlingate Plaza, Caller #28518, Columbus, OH 43228.~~

~~2.5 EMI/MADDDC Standard:~~

- ~~Nomenclature and Specifications for Truck-Mounted:~~
  - ~~(a) Extensible Aerial Devices,~~
  - ~~(b) Articulating Aerial Devices, and~~
  - ~~(c) Digger-Derricks<sup>77</sup>~~

**3. Terminology**

3.1 *Definitions:*

3.1.1 *acoustic emission (AE)*—the class of phenomena whereby elastic waves are generated by the rapid release of energy from a localized source or sources within a material, or the transient elastic wave(s) so generated. Acoustic emission is the recommended term for general use. Other terms that have been used in AE literature include stress wave emission, microseismic activity, and emission or acoustic emission with other qualifying modifiers.

3.1.2 *aerial personnel device*—any device extensible, articulating, or both, that is designed to position personnel.

3.1.3 *amplitude (acoustic emission signal amplitude)*—the peak voltage of the largest excursion attained by the signal wave form from an emission event.

3.1.4 *amplitude distribution*—a display of the number of acoustic emission events with signals that exceed an arbitrary amplitude as a function of amplitude.

3.1.5 *articulating-boom aerial device*—an aerial device with two or more hinged boom sections.

3.1.6 *attenuation*—loss of energy per unit distance.

3.1.7 *channel*—an input to the main AE instrument that accepts a preamplifier output.

3.1.8 *commoned*—two or more sensors interconnected such that the sensor outputs are electronically processed by a single channel without differentiation of sensor origin. (Synonym “teed”.)

3.1.9 *count (acoustic emission count), n*— the number of times the acoustic emission signal amplitude exceeds a preset threshold during any selected portion of a test.

3.1.10 *decibel (dB)*—logarithmic expression of a ratio of two single peak amplitudes. A reference scale expresses the logarithmic ratio of a single peak amplitude to a fixed reference amplitude.

$$\text{Signal peak amplitude (dB)} = 20 \log_{10} (A_1/A_0)$$

where:

$A_0$  = 1  $\mu$ V at the sensor output (before amplification), and

$A_1$  = peak voltage of the measured acoustic emission signal.

Acoustic Emission Reference Scale		
dB Value	Voltage at Sensor Output	Voltage at Integral Preamp Sensor Output (40 dB gain)
0	1 $\mu$ V	100 $\mu$ V
20	10 $\mu$ V	1 mV
40	100 $\mu$ V	10 mV
60	1 mV	100 mV
80	10 mV	1 V
100	100 mV	10 V

~~3.1.11 *event*~~

~~*event (acoustic emission event)*—3.1.11 a local material change giving rise to acoustic emission.~~

3.1.12 *event count (Ne)*—the number obtained by counting each discerned acoustic emission event once.

3.1.13 *extensible-boom aerial device*—an aerial device, except the aerial ladder type, with a telescopic or extensible boom.

3.1.14 *first-hit*—a mode of operation of AE monitoring equipment in which an event occurring on one channel will prevent all other channels from processing data for a specified period of time. The channel with a sensor closest to the physical location of the emission source will then be the only channel processing data from that source.

3.1.15 *insulated aerial device*—an aerial device designed with dielectric components to meet a specific electrical insulation rating.

3.1.16 *insulator*—any part of an aerial device such as, but not limited to, the upper boom, lower boom or supporting structure, made of a material having a high dielectric strength, usually FRP or the equivalent.

3.1.17 *noise*—any undesired signal that tends to interfere with the normal reception or processing of the desired signal.

3.1.18 *non-destructive testing*—the examination by various means of devices and their components without alteration of the original components, so that they may function as before.

3.1.19 *non-overcenter*—the feature of an aerial device where the upper boom cannot travel past vertical orientation with respect to the ground.

3.1.20 *overcenter*—the feature of an aerial device where the upper boom travels past vertical orientation with respect to the ground.

<sup>7</sup> Available from the Equipment Manufacturers' Institute, 410 N. Michigan Society of Plastics Industry, 355 Lexington Ave., Chicago, IL 60611; New York, NY 10017.

3.1.201 *qualified personnel*—personnel who, by possession of a recognized degree, certificate, professional standing, or skill, and who, by knowledge, training, and experience, have demonstrated the ability to deal with problems relating to the subject matter, the work, or the project.

3.1.242 *signal (emission signal)*—a signal obtained by detection of one or more acoustic emission events.

3.1.223 For definitions of other terms in this test method, refer to Terminology E 610 and the FIEI document in 2.4.

3.2 *Definitions of Terms Specific to This Standard* (see Figs. 1 and 2):

3.2.1 *elbow*—the structure connecting the upper boom to the lower boom, about which one articulates relative to the other.

3.2.2 *elbow pin*—the horizontal pin about which the upper boom rotates relative to the lower boom.

3.2.3 *lift cylinder*—The hydraulic cylinder that lifts the lower boom and the extensible boom(s).

3.2.4 *lower boom*—the structural member, attached to a turntable or base, that supports the upper boom.

3.2.5 *lower boom cylinder*—the hydraulic cylinder that articulates the lower boom.

3.2.6 *lower boom insulator*—the part of the lower boom made of high dielectric strength material (usually fiberglass reinforced plastic or equivalent).

3.2.7 *lower boom pin*—the horizontal pin about which the lower boom is raised and lowered relative to the turntable.

3.2.8 *outriggers*—the structural members that, when properly extended or deployed on firm ground, assist in stabilizing the vehicle on which the aerial device is mounted.

3.2.9 *pedestal*—the stationary base of the aerial device that supports the turntable.

3.2.10 *platform*—the personnel-carrying component of an aerial device, such as a bucket, basket, stand, or equivalent.

3.2.11 *platform pin*—the horizontal pin about which the platform rotates relative to the upper boom.

3.2.12 *rated platform capacity*—The maximum load as stated by the manufacturer for which an aerial device is designed to operate, consisting of the combined weight of the personnel and all items carried on or in the platform.

3.2.13 *stabilizers*—a means to assist in stabilizing the vehicle, such as outriggers, torsion bars, and spring lockouts.

3.2.14 *supplemental load-handling attachment (SLHA)*—a device(s) affixed to the upper-boom tip area which is designed to lift and or position materials.

3.2.15 *turntable*—the rotating base of the aerial device that supports the booms.

3.2.156 *upper boom*—the structural member, attached to the lower boom, that supports the platform.

3.2.167 *upper boom cylinder*—the hydraulic cylinder that articulates the upper boom.

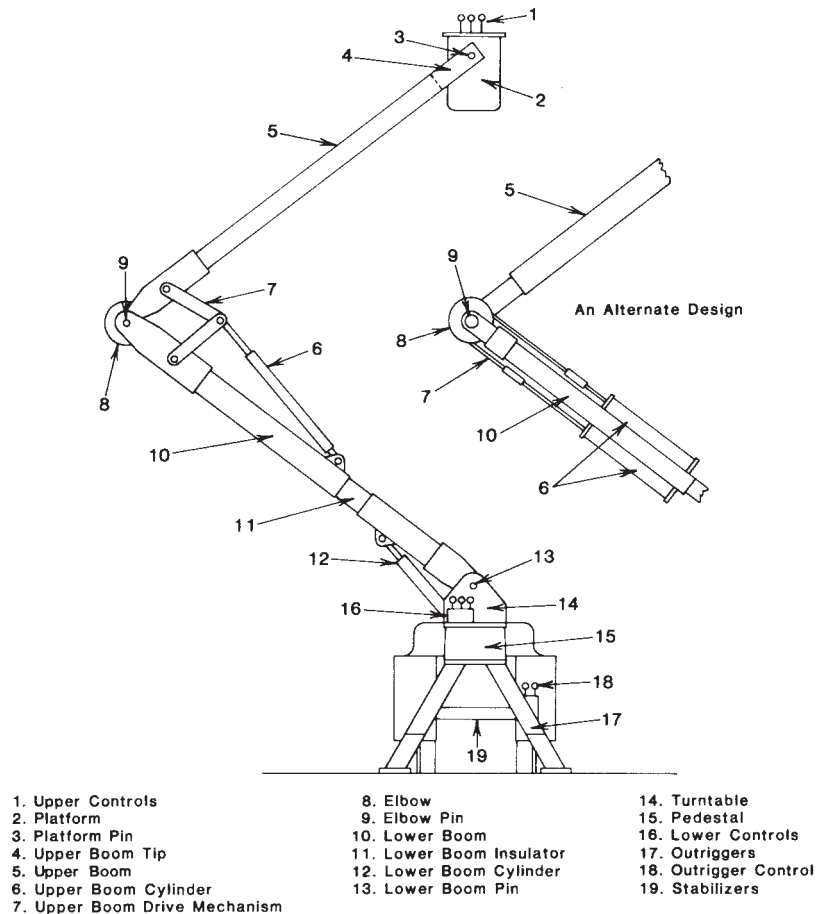

FIG. 1 Articulating Aerial Device Nomenclature Diagram

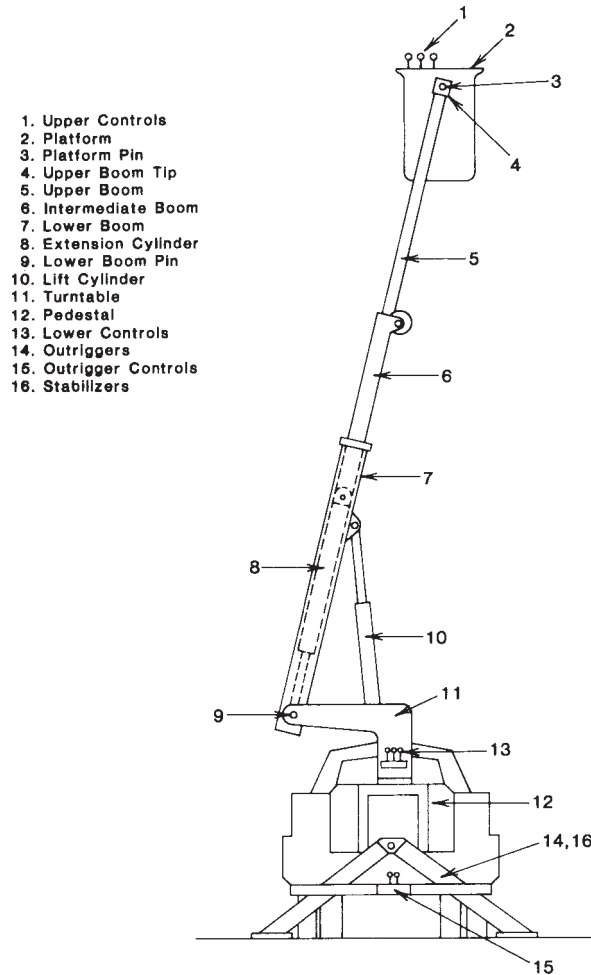

FIG. 2 Extensible Aerial Device Nomenclature Diagram

3.2.178 *upper boom drive mechanism*—means, such as linkage, cables, sheaves and gears, used to produce upper boom articulation.

3.2.189 *upper boom tip*—the end of the upper boom to which the platform is attached.

#### 4. Summary of Test Method

4.1 This test method consists of applying a predetermined load to an ~~insulated~~ aerial personnel device while it is being monitored by sensors that are sensitive to acoustic emissions (AE) caused by active defects. These acoustic emissions can be generated by, but are not limited to, the following: crack nucleation movement or propagation in the metal components; or matrix crazing, de\_lamination or fiber breakage of the fiberglass reinforced plastic (FRP) material; or both.

4.2 The ~~insulated~~ aerial personnel device is loaded at a uniform rate until a predetermined load is reached, which is held for a period of time. The load is removed and the cycle is repeated. Acoustic emissions are monitored during both cycles and the data are evaluated.

4.3 The test load used during an acoustic emission test on an ~~insulated~~ aerial personnel device shall be two times the rated platform capacity.

#### 5. Significance and Use

5.1 This test method provides a means of evaluating acoustic emissions generated by the rapid release of energy from localized sources within an ~~insulated~~ aerial personnel device under controlled loading. The resultant energy releases occur during intentional application of a controlled predetermined load. These energy releases can be monitored and interpreted by qualified individuals.

5.2 This test method permits testing of the major components of an ~~insulated~~ aerial personnel device under controlled loading. This test method utilizes objective criteria for evaluation and may be discontinued at any time to investigate a particular area of concern or prevent a fault from continuing to ultimate failure.

5.3 This test method provides a means of detecting acoustic emission sources that may be defects or irregularities, or both, affecting the structural integrity or intended use of the aerial personnel device.

5.4 Sources of acoustic emission found with this test method shall be evaluated by either more refined acoustic emission test methods or other nondestructive techniques (visual, liquid penetrant, radiography, ultrasonics, magnetic particle, etc.). Other nondestructive tests may be required to locate defects present in ~~insulated~~ aerial personnel devices.

5.5 Defective areas found in ~~insulated~~ aerial personnel devices by this test method should be repaired and retested as appropriate. Repair procedure recommendations are outside the scope of this test method.

## 6. Personnel Qualifications

6.1 This test method shall be performed by qualified personnel. Qualification shall be in accordance with an established written program, consistent with the established format of ASNT SNT-TC-IA for training, qualification, and certification of personnel for conducting AE testing of ~~insulated~~ aerial personnel devices.

NOTE 12—Personnel performing subsequent nondestructive evaluation (visual, liquid penetrant, radiography, ultrasonic, magnetic particle, etc.) on aerial devices shall be certified in accordance with ASNT SNT-TC-IA guidelines.

6.2 Acoustic emission test personnel shall be familiar with the design, manufacture, and operation of ~~insulated~~ aerial personnel devices. Relevant information is contained in ANSI A92.2 and manufacturers’ operating and service manuals.

## 7. Acoustic Emission Instrumentation

7.1 The AE instrument shall be capable of data acquisition in discrete channels within a frequency band of 20 to 200 kHz. The number of AE instrument channels shall be determined by the attenuation characteristics of the aerial device in order to provide coverage of those components identified in Table 1 or Table 2. A detailed description of instrumentation characteristics is included in Annex A1.

NOTE 23—Experience has shown that a minimum of eight channels of data acquisition is required. The instrument should be capable of recording the following: time, events, counts, amplitude and load. Hard copy records shall be provided by the instrument or available through a direct interface.

NOTE 34—A maximum of two sensors may be commoned on any one channel.

## 8. Test Preparation

8.1 Prior to the AE test, perform a visual observation of the aerial lift device to ensure that the components to be tested are free from any condition that may prohibit the test or adversely affect test results.

8.2 The components to be monitored in an ~~insulated~~ aerial personnel device shall include but not be limited to those specified in Table 1 or Table 2. Additional channels and sensors may be used to supplement the minimum test requirements and improve location resolution.

8.3 Position the sensors on the FRP and metal portions of the components identified in Table 1 or Table 2. The extent of the coverage is determined by the number of sensors used and the attenuation characteristics of the individual components, and can be verified by a simulated AE technique as indicated in Guide E 976. Record the amplitude of the simulated AE source at a distance of 12 in. (304 mm) from the sensor as a reference. Continue to move the simulated AE source away from the sensor until the amplitude is no more than 15 dB less than the reference amplitude. This will establish the maximum area of coverage of the sensor.

8.4 The mounting of sensors shall be in accordance with Practices E 569 and E 650. The couplant used shall not affect the performance of the aerial device.

**TABLE 1 Aerial Device Components That May Be Monitored With Acoustic Emission**

Component <sup>A</sup>	Identification	Articulated Aerial Device	Extensible Aerial Device
Platform	A	X <sup>B</sup>	X
Platform	A	X <sup>B</sup>	X
Platform attachment	B	X	X
Platform attachment	B	X	X
Upper Boom	C	X	X
Upper Boom	C	X	X
Upper and lower boom attachment of elbow	D	...	NA <sup>C</sup>
Upper and lower section of lower boom	E	...	NA
Lower boom insulator	F	X	...
Lower boom insulator	F	X	X
Turntable and rotation bearing	G	...	...
Pedestal	H	...	...
Intermediate boom	I	NA	...
Intermediate boom	X	NA	...
Lower boom	J	NA	...
Lower boom	J	NA	...X

<sup>A</sup>Refer to Figs. 1 and 2 for illustration of components.

<sup>B</sup>The use of the symbol "X" indicates the requirement to monitor this component with acoustic emission.

<sup>C</sup>The use of the symbol "NA" indicates that acoustic emission does not apply.

**TABLE 2 Aerial Device Steel Components That Should Be Monitored With Acoustic Emission**

Component <sup>A</sup>	Articulated Aerial Device	Extensible Aerial Device
Upper and lower boom attachment of elbow	X	X <sup>B</sup>
Upper and lower section of lower boom	X	NA <sup>C</sup>
Turntable	X	X
Pedestal	X	X

<sup>A</sup>Refer to Figs. 1 and 2 for illustration of components.

<sup>B</sup>The use of the symbol "X" indicates the requirement to monitor this component with acoustic emission.

<sup>C</sup>The use of the symbol "NA" indicates that acoustic emission does not apply.

NOTE 45—The couplant should be compatible with the aerial device, not a possible cause of contamination. The couplant should be completely removable from the surface after testing, leaving the original surface intact.

### 9. AE Instrumentation System Performance Check

9.1 Make performance verification of the AE system performance with an AE simulator immediately prior to application of test load. This simulator should be capable of producing a transient elastic wave having an amplitude representative of the AE signals to be recorded.

9.2 The AE simulator may be gas jet, pencil lead break technique or an electronically induced event or equivalent.

9.3 The detected peak amplitude of the simulated event at a fixed distance, typically 6 to 9 in. (152 to 228 mm), from each sensor shall not vary more than 6 dB from the average of all the sensors on the same type material. The detected peak amplitude of any sensor shall not exceed 90 dB to avoid saturation of amplifier(s).

9.4 A sensor performance check should be performed periodically in accordance with Practice F 2174.

### 10. Calibration

10.1 Subject the AE system to a thorough calibration and functional check to verify accurate performance in accordance with the manufacturer's specification, in conjunction with Practice E 750. Perform calibration annually as a minimum in accordance with a written calibration procedure. Include in the calibration, as a minimum: calibration of threshold levels, amplitude measurement circuits, count measurement circuits, AE sensors, and load measuring devices.

10.2 Subject the AE system to a routine performance check, which shall include as a minimum, verification of threshold levels and amplitude measurements. Performance checks should be conducted monthly or after 40 h of operation, whichever is more frequent measurements.

### 11. Procedure

11.1 Test articulating aerial personnel devices in positions such that the components indicated in Table 1 or Table 2 can be monitored. The recommended test positions as illustrated in Fig. 3 or their equivalents may be used.

11.2 Test extensible aerial personnel devices in positions such that the components indicated in Table 1 or Table 2 can be monitored. Recommended test position as illustrated in Fig. 4 or its equivalent may be used.

11.3 Attach the load measuring device to the load application system which in turn shall be attached to an adequate dead weight or anchor.

11.4 Recommended load attachment points are shown in Figs. 5 and 6. The method of load application and attachment shall evenly distribute the load and shall not permanently deform the platform.

11.5 The load connection technique used should simulate in-field use as closely as possible.

NOTE 56—Attach the load system to the bucket or platform so that the centerline of load application passes through Point(s) A-1. On units with two platforms, distribute the load evenly to both platforms or buckets.

NOTE 67—On units with platform rotators, the platform(s) shall be rotated until the centerline of the load application is at the maximum distance beyond the platform pin.

11.6 The test load employed at the points illustrated in Figs. 5 and 6 shall be two times the rated platform capacity.

11.7 All components of the load application system shall be capable of supporting the test load.

11.8 Perform the loading sequence as illustrated in Fig. 7.

11.9 As a minimum, record the following data during the test:

11.9.1 Events by channel (events versus time),

11.9.2 Counts versus time or load for metal channels,

11.9.3 Counts versus time or load for fiberglass channels,

11.9.4 Amplitude distribution for metal channels,

11.9.5 Amplitude distribution for fiberglass channels, and

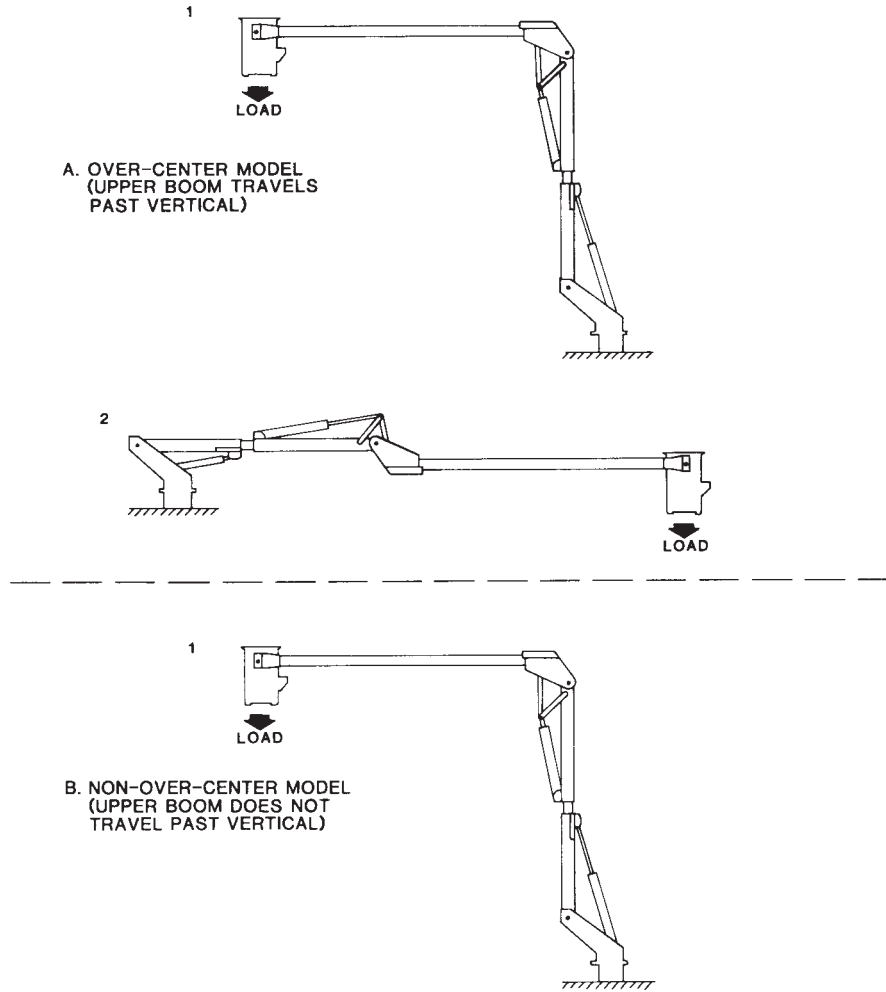

FIG. 3 Test Positions for Articulating Aerial Devices

11.9.6 Load versus time.

11.10 If any test data indicate to the operator that damage could be occurring to the device, stop the test and evaluate the condition or resolve the condition, or both, prior to restarting the test. Otherwise, complete the test procedure as outlined in 11.11 through 11.17 and evaluate the data.

11.11 Prior to applying load, use the AE instrumentation to detect background noise. If any background noise is observed, identify the source of the noise, and if possible, eliminate the noise before loading begins. If the background noise is excessive, reschedule the test for another time or location in order to eliminate the excessive background noise. Examples of potential background noise sources include electromagnetic interference such as close proximity to radio stations, improper grounding, rubbing interfaces, and impact.

11.12 Apply load at a uniform rate, between  $\bar{3}$  10 and 20 ~~lbf/s (13.3 and 89 N/s)~~, lbf/s, until the test load is attained.

11.13 Hold the test load for 4 min.

NOTE 78—The leak down rate of the aerial personnel devices hydraulic system could invalidate the AE data.

NOTE 89—Attach the loading system to the bucket or platform so that the center of load application is at Point C-1.

11.14 Remove the load at a uniform rate, between  $\bar{3}$  10 and 20 ~~lbf/s (13.3 and 89 N/s)~~, lbf/s.

11.15 Wait a minimum of 2 min prior to proceeding with the second loading.

11.16 For the second loading, repeat steps 11.12-11.14.

11.17 For each additional test position selected (see 11.1 or 11.2), repeat 11.3 through 11.16.

11.18 *Pass/Fail Criteria for Acoustic Emission Testing of FRP Components:*

11.18.1 The following acceptance criteria are valid only when using this test method and applied loads remain constant during hold cycles. The following AE responses from monitoring FRP components constitute acceptance:

11.18.1.1 Zero events or counts, or both, during the last 3 min of the second hold, at test load, or

11.18.1.2 Fewer total events or counts, or both, recorded during the second hold period at test load than the total events or counts, or both, recorded during the first hold period (Kaiser effect). A clear reduction in the rate of acoustic activity over both hold periods should also be observed (that is, the slope of events/time or counts/time decreases over the hold periods).



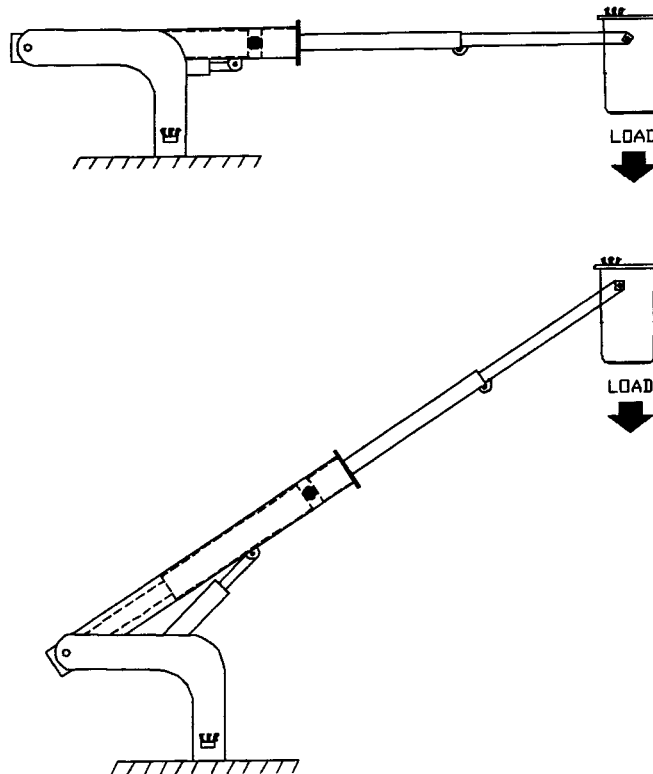

FIG. 4 Test Positions for Extensible Aerial Devices

11.18.2 Acoustic responses outside the previously described parameters are unacceptable to this test method. Suitability for service of FRP components that do not meet this test method must be carefully evaluated.

11.18.3 For sensors monitoring ductile components, acoustic activity during the loading and unloading phases of the test should not be excessive and should revert to minimal levels at the hold periods. Verification of these emission sources should be followed up by use of other non-destructive testing methods.

## 12. Report

12.1 *Test Instrumentation*—Instrument settings shall be included in all reports submitted for the examination. They shall be signed and dated by the responsible qualified personnel performing the tests. The information recorded shall be sufficient to permit complete reanalysis of the results. The information shall include, but is not limited to the following:

12.1.1 Sensor manufacturer, model number, serial numbers, and nominal peak frequency response, and serial number;

12.1.2 Methods of sensor attachment and type of couplant, and

12.1.3 Diagram and

12.1.2 Diagram or sketch of sensor locations including a description indicating areas of coverage.

12.2 *Aerial Device*— All submitted reports of the examination shall include, but not be limited to, the following information:

12.2.1 The aerial device manufacturer, model, and serial number,

12.2.2 General description; including rated platform capacity of the insulated personnel aerial device, and

12.2.3 Modifications, changes, repairs, and damage or suspected damage to the aerial device, where available.

12.3 *Other Test Information:*

12.3.1 Description of load application and measured test load sequence,

12.3.1.1 Identify the type of load application; that is, constant load versus time or constant displacement versus time,

12.3.1.2 Report the variation of load versus time during each of the load hold periods in pounds or percent of full load,

12.3.2 The method used for determination of the test load,

12.3.3 Permanent data record in the form of charts, graphs or event line listings, or combination thereof,

12.3.4 Ambient conditions during test, such as wind temperature, rain, etc., and

12.3.5 Any additional information that may be of use.

12.4 Any departure from the procedures specified in this test method shall be adequately justified and documented in the test record.

## 13. Precision and Bias

13.1 Each testing agency has the responsibility of judging the acceptability of its own results. The precision of the results is a function of the procedures, facilities utilized, as well as compliance to the recommended industry state-of-the-art practices.

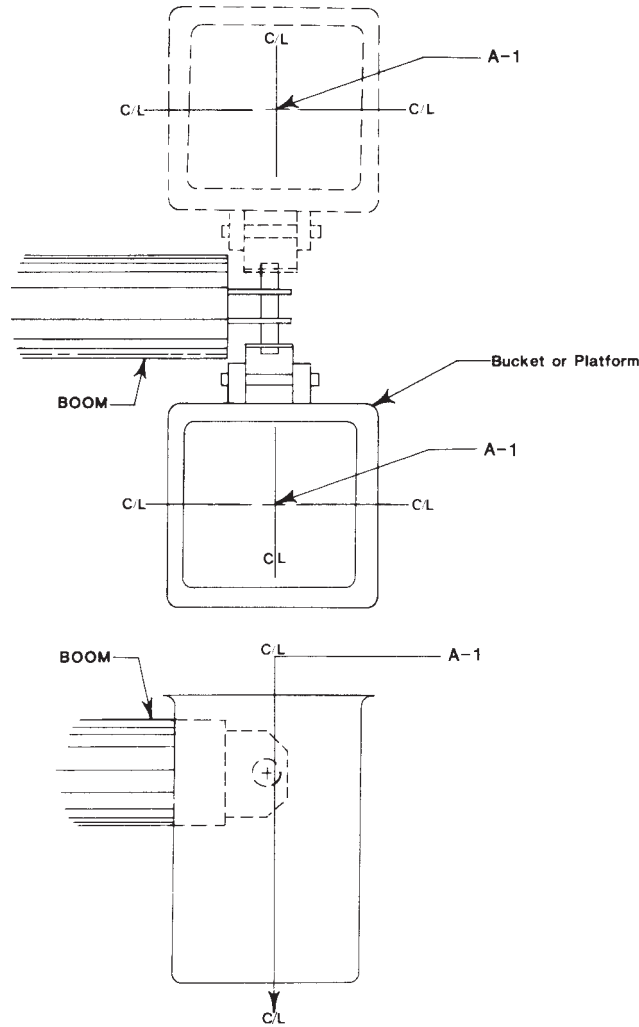

NOTE 1—Attach the load system to the bucket or platform so that the centerline of load application passes through Point(s) A-1. On units with two platforms, distribute the load evenly to both platforms or buckets.

NOTE 2—On units with platform rotators, the platform(s) shall be rotated until the centerline of the load application is at the maximum distance beyond the platform pin.

**FIG. 5 Point of Load Application for Side Mounted Platforms**

Reproducible analysis determinations by different users can be achieved only with identical facilities and trained conscientious personnel.

**14. Keywords**

14.1 acoustic; emission; equipment; ~~insulated~~ aerial devices

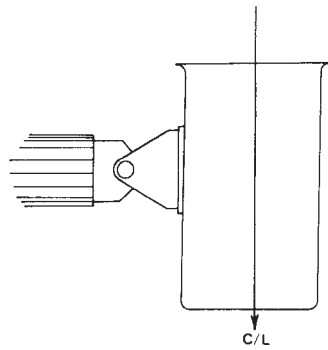
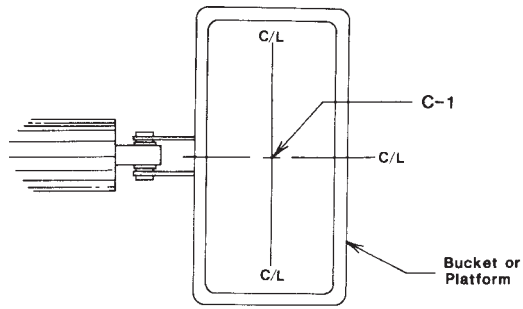

NOTE 1—Attach the loading system to the bucket or platform so that the center of load application is at Point C-1.

FIG. 6 Point of Load Application for End-Mounted Platforms

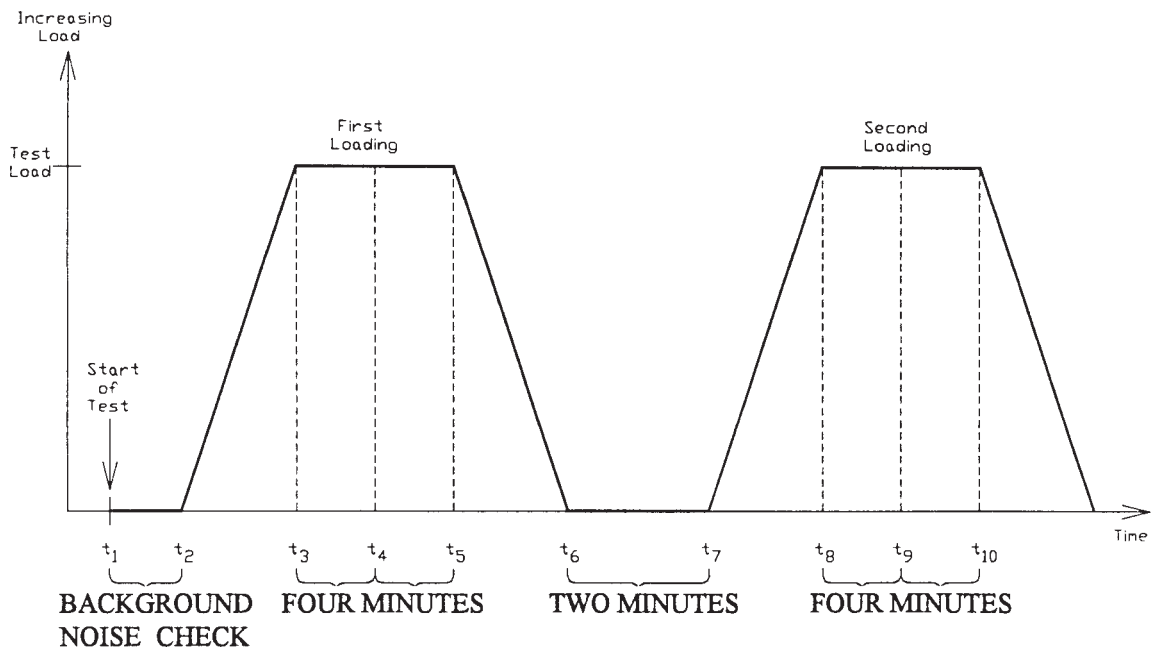

FIG. 7 Aerial Device Loading Sequence

## ANNEX

## (Mandatory Information)

## A1. INSTRUMENT PERFORMANCE REQUIREMENTS

A1.1 *Sensors* —AE sensors shall be stable over the temperature range of use, and shall not exhibit sensitivity changes greater than 3 dB over this range. Sensors shall be shielded against radio frequency and electromagnetic noise interference through proper shielding practice or differential (anticoincident) element design, or both. Sensors shall have omnidirectional response, with variations not exceeding 4 dB from the peak response.

A1.1.1 *High Frequency Sensors*, used on metal components of the aerial device, should have the primary resonant frequency at  $150 \pm 10$  kHz. Minimum sensitivity shall be  $-80$  dB referred to 1 V per microbar, or  $-40$  dB for integral preamp sensors as determined by face-to-face ultrasonic swept-frequency calibration. AE sensors used in the same test should not vary in peak sensitivity more than 3 dB from the average.

A1.1.2 *Low Frequency Sensors*, used on fiberglass components of the aerial device, should have the primary resonant frequency at  $60 \pm 10$  kHz. Minimum sensitivity shall be equivalent or greater than high sensitivity accelerometers designed for use at 60kHz.

A1.1.3 Up to two sensors may be commoned into a single channel.

A1.2 *Signal Cable* —The signal cable from sensor to preamplifier shall not exceed 6 ft (1.8 m) in length and shall be shielded against electromagnetic interference. This requirement is omitted where the preamplifier is mounted in the sensor housing, or a line-driving (matched impedance) sensor is used.

A1.3 *Preamplifier* —The preamplifier may be separate or may be mounted in the sensor housing. For sensors with integral preamplifiers, frequency response characteristics may be confined to a range consistent with the operational frequency of the sensor. If the preamplifier is of differential design, a minimum of 40 dB of common-mode noise rejection shall be provided. Unfiltered frequency response shall not vary more than 3 dB over the frequency range of 20 to 400 kHz, and over the temperature range of use.

A1.4 *Filters* —Filters shall be of the band pass or high pass type, and shall provide a minimum of  $-24$  dB/octave signal attenuation. Filters may be located in preamplifier or post-preamplifier circuits or may be integrated into the component design of the sensor, preamplifier, or processor to limit frequency response. Filters or integral design characteristics, or both, shall ensure that the principal processing frequency for high frequency sensors is not less than 100 kHz, and for low frequency sensors, not less than 25 kHz.

A1.5 *Power-Signal Cable*—The cable providing power to the preamplifier and conducting the amplified signal to the main processor shall be shielded against electromagnetic noise. Signal loss shall be no more than 1 dB per 100 ft (30.4 m) of cable length. Five hundred feet (152 m) is the recommended maximum cable length to avoid excessive signal attenuation. Digital or radio transmission of signals is allowed consistent with standard practice in transmitting those signal forms.

A1.6 *Main Amplifiers* —The main amplifier, if used, shall have signal response with variations not exceeding 3 dB over the frequency range of 20 to 400 kHz, and temperature range of use. The main amplifier shall have adjustable gain, or an adjustable threshold for event detection and counting.

A1.7 *Main Processor* :

A1.7.1 *General*—The main processors shall have a minimum of eight independent channel inputs for signal processing of events. If mixer(s) are used, first-hit event processing for each channel must be provided.

A1.7.1.1 Independent processing of counts, events, and amplitude (per event) for each channel is preferred; but as a minimum, two active processing circuits shall process counts and amplitude information from metal and fiberglass channels independently.

A1.7.1.2 The system shall be capable of processing and storing at least 100 events per second for limited periods of time.

A1.7.2 *Peak Amplitude Detection*—Usable dynamic range shall be a minimum of 60 dB with 5 dB resolution over the frequency band of 20 to 400 kHz, and the temperature range of use. Not more than 2 dB variation in peak detection accuracy shall be allowed over the stated temperature range. Amplitude values may be stated in volts or dB, but must be referenced to a fixed gain output of the system (sensor or preamp).

A1.7.3 *Source Location*— Source location using time difference processing between channels is optional, and may be used where it improves source identification on the structure. However, use of the source location algorithms shall not prohibit processing of individual or first-hit sensor information.

A1.7.4 *Signal Outputs and Recording* —The processor shall provide as a minimum outputs for permanent recording of:

A1.7.4.1 Events by channel (events versus time),

- A1.7.4.2 Counts versus time or load for metal channels,
- A1.7.4.3 Counts versus time or load for fiberglass channels,
- A1.7.4.4 Amplitude distribution for metal channels,
- A1.7.4.5 Amplitude distribution for fiberglass channels, and
- A1.7.4.6 Load versus time.

NOTE A1.1—The required outputs should be based on first hit information.

A1.7.5 *Load Measuring Device*—The load cell or other load measuring device shall be capable of registering the loads applied during testing within its calibration range. The device shall be calibrated in a manner and at intervals recommended by the manufacturer's specifications. The percent error for loads within the loading range of the load cell and readout shall not exceed  $\pm 1.0\%$  of reading. In load readouts that possess multiple-capacity ranges, the verified loading of each range shall not exceed  $\pm 1.0\%$  of reading. An electronic output of the load measuring device, proportional to applied load, shall be properly conditioned and amplified to match the requirements of the recording device used.

*ASTM International takes no position respecting the validity of any patent rights asserted in connection with any item mentioned in this standard. Users of this standard are expressly advised that determination of the validity of any such patent rights, and the risk of infringement of such rights, are entirely their own responsibility.*

*This standard is subject to revision at any time by the responsible technical committee and must be reviewed every five years and if not revised, either reapproved or withdrawn. Your comments are invited either for revision of this standard or for additional standards and should be addressed to ASTM International Headquarters. Your comments will receive careful consideration at a meeting of the responsible technical committee, which you may attend. If you feel that your comments have not received a fair hearing you should make your views known to the ASTM Committee on Standards, at the address shown below.*

*This standard is copyrighted by ASTM International, 100 Barr Harbor Drive, PO Box C700, West Conshohocken, PA 19428-2959, United States. Individual reprints (single or multiple copies) of this standard may be obtained by contacting ASTM at the above address or at 610-832-9585 (phone), 610-832-9555 (fax), or [service@astm.org](mailto:service@astm.org) (e-mail); or through the ASTM website ([www.astm.org](http://www.astm.org)).*