



Designation: E 1392 – 96

Standard Practice for Angle Resolved Optical Scatter Measurements on Specular or Diffuse Surfaces¹

This standard is issued under the fixed designation E 1392; the number immediately following the designation indicates the year of original adoption or, in the case of revision, the year of last revision. A number in parentheses indicates the year of last reapproval. A superscript epsilon (ϵ) indicates an editorial change since the last revision or reapproval.

This standard has been approved for use by agencies of the Department of Defense.

1. Scope

1.1 This practice explains a procedure for the determination of the amount and angular distribution of optical scatter from an opaque surface. In particular it focuses on measurement of the bidirectional reflectance distribution function (BRDF). BRDF is a convenient and well accepted means of expressing optical scatter levels for many purposes (1,2).² Additional data presentation formats described in Appendix X1 have advantages for certain applications. Surface parameters can be calculated from optical scatter data when assumptions are made about model relationships. Some of these extrapolated parameters are described in Appendix X2.

1.2 Optical scatter from an opaque surface results from surface topography, surface contamination, and subsurface effects. It is the user's responsibility to be certain that measured scatter levels are ascribed to the correct mechanism. Scatter from small amounts of contamination can easily dominate the scatter from a smooth surface. Likewise, subsurface effects may play a more important scatter role than typically realized when surfaces are superpolished.

1.3 This practice does not provide a method to extrapolate data for one wavelength from data for any other wavelength. Data taken at particular incident and scatter directions are not extrapolated to other directions. In other words, no wavelength or angle scaling is to be inferred from this practice. Normally the user must make measurements at the wavelengths and angles of interest.

1.4 This practice applies only to BRDF measurements on opaque samples. It does not apply to scatter from translucent or transparent materials. There are subtle complications which affect measurement of translucent or transparent materials that are best addressed in separate standards (see Practice E 167 and Guide E 179).

1.5 The wavelengths for which this practice applies include the ultraviolet, visible, and infrared regions. Difficulty in

obtaining appropriate sources, detectors, and low scatter optics complicate its practical application at wavelengths less than about 0.25 μm . Diffraction effects that start to become important for wavelengths greater than 15 μm complicate its practical application at longer wavelengths. Diffraction effects can be properly dealt with in scatter measurements (3), but they are not discussed in this practice.

1.6 Any experimental parameter is a possible variable. Parameters that remain constant during a measurement sequence are reported as header information for the tabular data set. Appendix X3 gives a recommended reporting format that is adaptable to varying any of the sample or system parameters.

1.7 This practice applies to flat or curved samples of arbitrary shape. However, only a flat, circular sample is addressed in the discussion and examples. It is the user's responsibility to define an appropriate sample coordinate system to specify the measurement location on the sample surface for samples that are not flat.

1.8 The apparatus and measurement procedure are generic, so that specific instruments are neither excluded nor implied in the use of this practice.

1.9 *This standard does not purport to address the safety concerns, if any, associated with its use. It is the responsibility of the user of this standard to establish appropriate safety and health practices and determine the applicability of regulatory limitations prior to use.*

2. Referenced Documents

2.1 ASTM Standards:

E 167 Practice for Goniophotometry of Objects and Materials³

E 179 Guide for Selection of Geometric Conditions for Measurement of Reflection and Transmission Properties of Materials³

E 284 Terminology Relating to Appearance³

F 1048 Test Method for Measuring the Effective Surface Roughness of Optical Components by Total Integrated Scattering⁴

2.2 ANSI Standard:

¹ This practice is under the jurisdiction of ASTM Committee F01 on Electronics and is the direct responsibility of Subcommittee F01.06 on Silicon Materials and Process Control.

Current edition approved Dec. 10, 1996. Published December 1997. Originally published as E 1392 - 90. Last previous edition E 1392 - 90.

² The boldface numbers in parentheses refer to a list of references at the end of the text.

³ *Annual Book of ASTM Standards*, Vol 06.01.

⁴ *Annual Book of ASTM Standards*, Vol 10.05.

ANSI/ASME B46.1, Surface Texture (Surface Roughness, Waviness, and Lay)⁵

3. Terminology

3.1 Definitions:

3.1.1 Definitions of terms not included here will be found in Terminology E 284 or ANSI Standard B 46.1. Additional graphic information will be found in Figs. A1.1-A1.3 in Annex A1.

3.2 Definitions of Terms Specific to This Standard:

3.2.1 *angle of incidence*, θ_i —polar angle between the central ray of the incident flux and the ZB axis.

3.2.2 *beam coordinate system, XB YB ZB*—a cartesian coordinate system with the origin on the central ray of the incident flux at the sample surface, the XB axis in the plane of incidence (PLIN) and the ZB axis normal to the surface as shown in Fig. A1.1.

3.2.2.1 *Discussion*—The angle of incidence, scatter angle, and incident and scatter azimuth angles are defined with respect to the beam coordinate system.

3.2.3 *bidirectional reflectance distribution function, BRDF*—the sample radiance divided by the sample irradiance. The procedures given in this practice are correct only if the field of view (FOV) determined by the receiver field stop is sufficiently large to include the entire illuminated area for all angles of incidence of interest.

$$BRDF = \frac{L_c}{E_c} = \frac{(P_s / \Omega A \cos \theta_s)}{(P_i / A)} = \frac{P_s}{P_i \Omega \cos \theta_s} [sr^{-1}] \quad (1)$$

3.2.3.1 *Discussion*—BRDF is a differential function dependent on the wavelength, incident direction, scatter direction, and polarization states of the incident and scattered fluxes. In practice, it is calculated from the average radiance divided by the average irradiance. The BRDF of a lambertian surface is independent of scatter direction. If a surface scatters nonuniformly from one position to another then a series of measurements over the sample surface must be averaged to obtain suitable statistical uncertainty. Nonuniformity may be caused by irregularity of the surface microroughness or film, optical property nonhomogeneity, or subsurface defects.

3.2.4 *cosine-corrected BRDF*—the BRDF times the cosine of the scatter polar angle.

3.2.4.1 *Discussion*—The $\cos \theta_s$ in the BRDF definition is a result of the radiometric definition of BRDF. It is sometimes useful to express the scattered field as normalized scatter intensity [(watts scattered/solid angle)/incident power] as a function of scatter direction. This is accomplished by multiplying the BRDF by $\cos \theta_s$.

3.2.5 *delta beta*, $\Delta\beta$ —the projection of $\Delta\beta$ onto the XB-YB plane, that is, the delta theta angle measured in direction cosine space. For scatter in the PLIN, $\Delta\beta = \sin \theta_s - \sin \theta_i$. For scatter out of the plan of incidence (PLIN), the calculation of $\Delta\beta$ becomes more complicated (see Appendix X1.2).

3.2.6 *delta theta*, $\Delta\theta$ —the angle between the specular direction and the scatter direction.

3.2.7 *incident azimuth angle*, ϕ_i —the fixed 180° angle from

the XB axis to the projection of the incident direction onto the XB-YB plane.

3.2.7.1 *Discussion*—It is convenient to use a beam coordinate system (refer to Fig. A1.2) in which $\phi_i = 180^\circ$, since this makes ϕ_s the correct angle to use directly in the familiar form of the grating equation. Conversion to a sample coordinate system is straight forward, provided the sample location and rotation are known.

3.2.8 *incident direction*—the central ray of the incident flux specified by θ_i and ϕ_i in the beam coordinate system.

3.2.9 *incident power*, P_i —the radiant flux incident on the sample.

3.2.9.1 *Discussion*—For relative BRDF measurements, the incident power is not measured directly. For absolute BRDF measurements it is important to verify the linearity, and if necessary correct for the nonlinearity, of the detector system over the range from the incident power level down to the scatter level which may be as many as 13 to 15 orders of magnitude lower. If the same detector is used to measure the incident power and the scattered flux, then it is not necessary to correct for the detector responsivity; otherwise, the signal from each detector must be normalized by its responsivity.

3.2.10 *instrument signature*—the mean scatter level detected when there is no sample scatter present expressed as BRDF.

3.2.10.1 *Discussion*—Since BRDF is defined only for a surface, the instrument signature provides an equivalent BRDF for the no-sample situation. The limitation on instrument signature is normally stray scatter from instrument components and out-of-plane aperture position errors for receiver positions near the specular direction. For high grade electronic detection systems, at large scatter angles, the limitation on instrument signature is normally Rayleigh scatter from molecules within the volume of the incident light beam that is sampled by the receiver field of view. As θ_s approaches 90°, the accuracy of θ_s becomes important because of the $1/\cos \theta_s$ term in BRDF. The signature can be measured by scanning a very low scatter reference sample in which case the signature is adjusted by dividing by the reference sample reflectance. The signature is commonly measured by moving the receiver near the optical axis of the source and making an angle scan with no sample in the sample holder. It is necessary to furnish the instrument signature when reporting BRDF data so that the user can decide at what scatter direction the sample BRDF is lost in the signature.. Preferably the signature is several decades below the sample data and can be ignored.

3.2.11 *noise equivalent BRDF, NEBRDF*—the root mean square (r/min) of the noise fluctuation expressed as equivalent BRDF.

3.2.11.1 *Discussion*—Measurement precision is limited by the acceptable signal to noise ratio with respect to these fluctuations. It should be noted that although the detector noise is independent of θ_s , the NEBRDF will increase at large values of θ_s because of the $1/\cos \theta_s$ factor. Measurement precision can also be limited by other experimental parameters as discussed in Section 10. The NEBRDF can be measured by blocking the source light.

3.2.12 *plane of incidence, PLIN*—the plane containing the

⁵ Available from American National Standards Institute, 1430 Broadway, NY, NY 10018.

sample normal and central ray of the incident flux.

3.2.13 *receiver*—a system that generally contains apertures, filters and focussing optics that gathers the scatter signal over a known solid angle and transmits it to the scatter detector element.

3.2.14 *receiver solid angle*, Ω —the solid angle subtended by the receiver aperture stop from the sample origin.

3.2.15 *sample coordinate system*—a coordinate system fixed to the sample and used to specify position on the sample surface for the measurement.

3.2.15.1 *Discussion*—The sample coordinate system is application and sample specific. The cartesian coordinate system shown in Fig. A1.1 is recommended for flat samples. The origin is at the geometric center of the sample face with the Z axis normal to the sample. A fiducial mark must be shown at the periphery of the sample; it is most conveniently placed along either the X or Y axes. For silicon wafers, the fiducial mark is commonly placed on the y -axis.

3.2.16 *sample irradiance*, E_e —the radiant flux incident on the sample surface per unit area.

3.2.16.1 *Discussion*—In practice, E_e is an average calculated from the incident power, P_i , divided by the illuminated area, A . The incident flux should arrive from a single direction; however, the acceptable degree of collimation or amount of divergence is application specific and should be reported.

3.2.17 *sample radiance*, L_e —a differential quantity that is the reflected radiant flux per unit projected receiver solid angle per unit sample area.

3.2.17.1 *Discussion*—In practice, L_e is an average calculated from the scattered power, P_s , collected by the projected receiver solid angle, $\Omega \cos \theta_s$, from the illuminated area, A . The receiver aperture and distance from the sample determines Ω and the angular resolution of the instrument.

3.2.18 *scatter*—the radiant flux that has been redirected over a range of angles by interaction with the sample.

3.2.19 *scatter azimuth angle*, ϕ_s —angle from the XB axis to the projection of the scatter direction onto the XB - YB plane.

3.2.20 *scatter direction*—the central ray of the collection solid angle of the scattered flux specified by θ_s and ϕ_s in the beam coordinate system.

3.2.21 *scatter plane*—the plane containing the central rays of the incident flux and the scatter direction.

3.2.22 *scatter polar angle*, θ_s —polar angle between the central ray of the scattered flux and the ZB axis.

3.2.23 *specular direction*—the central ray of the reflected flux that lies in the PLIN with $\theta_s = \theta_i$ and $\phi_s = 0$.

4. Significance and Use

4.1 The angular distribution of scatter is a property of surfaces that may have direct consequences. Scatter from mirrors and other components in an optical system can be the limiting factor in resolution or optical signal to noise level. Scatter can be an important design parameter for telescopes. Scatter measurements are crucial to correct operation of ring laser gyros. Scatter from a painted surface such as on automobiles can influence sales appeal.

4.2 The angular distribution of scatter from optically smooth surfaces can be used to calculate surface parameters or reveal surface characteristics. For example, the total scatter

found by integrating the BRDF over the hemisphere can be related to surface roughness. The amount of scatter at a given scatter angle can be associated with a specific surface spatial frequency.

4.3 The microroughness and contamination due to particulates and films on silicon wafers are interrogated with varying forms of light scattering techniques. The angular distribution of light scattered by semiconductor surfaces is a generalized basis for most scanning surface inspection systems and as such may be used to cross-correlate various tools.

5. Apparatus

5.1 *General*—Non-specular reflectometers or instruments (4) used to measure scattered light utilizes some form of the five components described in this section. These components are described in a general manner so as to not exclude any particular type of scatter instrument. To achieve $(\theta_i, \phi_i; \theta_s, \phi_s)$ positioning the instrument design must incorporate four df between the source, sample holder, and receiver assemblies.

5.2 *Source Assembly*—containing the source and associated optics to produce irradiance, E_e , on the sample over a specified spot area, A . If a broad band source is used, the wavelength selection technique should be specified. Depending on the bandwidth and selection techniques, the detector assembly may affect the wavelength sensitivity. If a laser source is used, it is usually sufficient to specify the center wavelength; however, it is sometimes necessary to be more specific such as providing the particular line in a CO_2 laser.

5.2.1 A source monitor is used to correct for fluctuations in the source intensity. If it is located at the source output it only measures variations in the source power and is not sensitive to variations due to angular drift or downstream transmission. The source monitor should monitor incident power as close to the sample as possible while minimizing additional system scatter. Attention should be paid to possible laser mode hopping and consequent wander of the beam on spatial filter pinholes and to fluctuations in source polarization.

5.2.2 Collimated or slightly converging source light can be used to measure *BRDF*. Most instruments use a converging beam focused at the receiver. If the convergence angle is small, the uncertainty introduced by a non-unique angle of incidence is usually negligible. The same considerations apply if a curved sample is measured. It is the user's responsibility to assure that any spread in θ_i does not compromise the results. Normal practice limits convergence to $f/20$ or greater with a focus at the receiver to increase the angular resolution of measurements near the specular beam or diffraction peaks.

5.2.3 Typically the source assembly is fixed in position and variations in θ_i are made with the sample holder. *Good reduction of the instrument signature requires baffling around the source assembly and use of a spatial filter to limit off-axis light. The final mirror (or lens) which directs light to the sample should have low scatter, since it contributes directly to small angle scatter in the instrument signature.*

5.2.4 A means should be provided for controlling the polarization state of the incident flux as this can impact the measured BRDF. Orthogonal source polarization components (parallel, or p , and perpendicular, or s) are defined relative to

the plane defined by the source direction and the sample surface normal.

5.2.5 Absorbing samples may be heated by the incident flux and may change their scatter characteristics, mechanically distort or burn. Special care must be taken with IR laser sources on absorbing samples.

5.3 *Sample Holder*—The sample holder should provide a secure mount for the sample that does not introduce any warp. The rotation axes of the stages that achieve the $(\theta_i, \phi_i, \theta_s, \phi_s)$ positioning must be relative to the sample front surface; this can be accomplished by orienting the sample holder or the source, or both, and receiver assemblies. Some sample mounts incorporate positioning stages for a raster scan of the sample surface at fixed incident and scatter angles. The sample mount must be kept unobtrusive so that it does not contribute stray flux to the signature or block large θ_s scatter.

5.4 *Beam Dump*—It is important to trap any specular reflection from the sample so that it cannot contribute to the scatter signal through lab/instrument reflections. Examples of beam dumps are black paper, a razor blade stack, absorbing glass plates, or a tapered blackened glass tube.

5.5 *Receiver Assembly*—If the system design includes df at the receiver for achieving the scatter direction, then the receiver assembly should normally have provisions for rotating about an axis on the front face of the sample in order to vary θ_s . If out of the PLIN measurements are required, the receiver assembly may also rotate out of the PLIN. This capability may also be provided by pitch, yaw, and roll of the sample, but it becomes more difficult to dump the specularly reflected beam.

5.5.1 The acceptance aperture for the receiver must be well defined, since the solid angle, Ω , subtended by the receiver aperture stop from the sample, is used in the BRDF calculation and defines the angular resolution. The field of view of the detector must include the entire irradiated area, A . There can be an exception to these requirements if a relative BRDF or relative total reflectance normalization is used. In that case it is the user's responsibility to ensure that the system parameters remain constant between measurements.

5.5.2 If the acceptance aperture is too small and a coherent source is used to irradiate the sample, speckle may cause strong, unpredictable variations in the scatter. This is a common problem when measuring diffuse (that is, rough) samples. It is sometimes desirable to spin a diffuse sample about its normal to average the effects of speckle while making a measurement. It is the user's responsibility to ensure that BRDF features are not due to speckle. The user may wish to employ a variable aperture stop to trade sensitivity for angular resolution when measuring specular surfaces, since best angular resolution is needed near specular where BRDF has a steep slope. Best sensitivity is needed at larger angles where BRDF might approach the NEBRDF.

5.5.3 It may be necessary to use an optical bandpass filter on the detector to minimize acceptance of background light. This can also be accomplished by modulating the amplitude (with a mechanical chopper) of the source light, and using a synchronized, phase sensitive (lock-in) amplifier with the detector.

5.5.4 Since depolarization can occur in scattering, complete characterization of scatter requires measurements with a polar-

ization analyzer at the receiver. The scatter reflex can be broken into perpendicular and parallel components that are respectively perpendicular and parallel to the scatter plane (see Fig. A1.2).

6. Calibration and Normalization

6.1 *General*—Instrument calibration is often confused with measurement of P_i . *Calibration of a BRDF instrument involves systematic standardization and verification of its quantitative results. Incident power must be measured for correct normalization of the scattered power. Absolute measurement of powers is not required as long as the P_s/P_i ratio is correctly measured. Alternatively, a reference sample can be used as a normalization reference.*

6.2 *Calibration*—A leading cause of inaccuracy in BRDF measurement is a lack of instrument calibration. An error analysis of the four quantities defining the BRDF ($P_i, P_s, \Omega, \theta_s$) can help to accomplish a calibration (5). Each of these four independent variables is a function of system parameters. For example, P_s depends on receiver linearity, electrical noise and system alignment parameters. The total error is also a function of incidence angle and scatter angle. It is reasonable to expect errors in the 3 to 10 % range for measurements taken a few degrees from specular to about $\theta_s = 85^\circ$. System nonlinearity is a major contributor to error in this central region. At either end of this central region errors rise dramatically. Near specular this is caused by out of plane receiver position error, and near the grazing angle the increase is due to uncertainty in θ_s . Error is also a function of the type of sample being measured. For example, larger errors are expected in the relatively steep BRDF associated with specular samples than for the flatter response of a diffuse surface.

6.2.1 The receiver and preamplifier must be calibrated together over their useful operating range. The final result is a calibration curve showing relative optical power versus voltage for each preamplifier gain setting. Operating regimes are selected for each gain setting to avoid saturating the detector while remaining on a low gain setting. The source monitor must also be calibrated in the same way.

6.2.2 There are several ways to vary the optical power and make this calibration curve. Optical filters with a known attenuation can be used, but multiple reflections and coherent effects (interference between the two filter faces) can change the attenuation. An excellent method of changing the optical power at the receiver is by moving away from a diffuse source for $1/r^2$ attenuation. Other methods include crossed polarizers or changing the duty cycle of a chopper. The user must select an attenuation method with suitable reproducibility to perform the calibration.

6.2.3 The receiver and preamplifier each have a maximum output voltage to avoid saturation, but there is also a minimum electronic noise level which should be kept in mind to avoid reporting noise as BRDF. When electronic noise is expressed as NEBRDF, note that although the noise may be constant, NEBRDF depends on the receiver solid angle, Ω , the incident power, P_i , and $\cos \theta_s$. This means NEBRDF can be lowered by changing these system parameters.

6.2.4 A full system calibration is not required on a daily basis, but the system should be checked daily. This check can

be accomplished by measuring the instrument signature and a stable reference sample that provides data over several decades. Changes from past results are an indication of calibration problems and the cause of the change must be determined. It is good operating practice to maintain a reference sample at the scatter facility for this calibration check. Recalibration must be accomplished when components are changed, repaired or realigned. Include a data file number for the most recent reference sample measurement with every set of BRDF data as a record of instrument response in case the data set is questioned at a later time.

6.3 *Normalization*—There are four acceptable methods for normalizing the scattered power to the incident power. Each method is dependent on different measured parameters.

6.3.1 *Absolute*—An absolute normalization is made by moving the receiver assembly onto the optical axis of the source with no sample in the sample holder. *This method depends on extending receiver calibration to high power levels.* The entire incident beam must enter the receiver assembly and a voltage, V_i , is recorded. *If the unsaturated detector response is R_λ (watts/volt):*

$$P_i = V_i R_\lambda \quad (2)$$

It is not necessary to know R_λ for the sample BRDF calculation if it remains constant. The source monitor voltage, V , must also be recorded at this time.

6.3.2 *Relative BRDF*—A relative normalization is made by measuring a reference sample that has a known BRDF level. *This method depends on knowing the reference sample BRDF.* This reference sample is usually a high reflectance, diffuse surface. They are readily available for visible wavelengths and the BRDF is the same for a large range of θ_i and θ_s . *Ideally the reference sample has a known BRDF that is similar to the unknown sample to be tested in both magnitude and incident/scatter directions, but this is rarely true. The reference sample should be spatially uniform and isotropic to alleviate alignment concerns.*

6.3.2.1 The reference sample is inserted in the sample holder and a detector voltage, V , corresponding to the scattered light for the known BRDF is recorded. The following can now be calculated:

$$P_i = VR_\lambda / \text{BRDF} \Omega \cos \theta_s \quad (3)$$

It is not necessary to know Ω or θ_s for the sample BRDF calculation if they remain constant. The source monitor voltage, V , must also be recorded at this time.

6.3.3 *Relative Specular Reflectance*—An alternative relative normalization can be made with a specular reference sample having a known specular reflectance, R . *This method depends on knowing R for the same collection solid angle as used in the P_i measurement.*

6.3.3.1 Insert the specular reference sample in the sample holder and measure the voltage, V_r , for the entire specular beam into the receiver assembly. The following can now be calculated:

$$P_i = V_r R_\lambda / R \quad (4)$$

It is not necessary to know R_λ for the sample BRDF calculation if it remains constant. The source monitor voltage, V , must also be recorded at this time.

6.3.4 *Relative Total Reflectance*—The fourth method involves integration of relative BRDF over the hemisphere and adjustment of constants to match the directional hemispherical reflectance, ρ (also referred to as total hemispherical reflectance). Normalization can only be accomplished after sufficient scatter data are accumulated to define the integral. *This method depends on a separately measured directional hemispherical reflectance and knowing relative scatter over the entire hemisphere.* It is best suited to isotropic, diffuse samples.

6.3.4.1 When sufficient scatter data has been accumulated the following integral is performed.

$$\rho_{\text{calc}} = \int_0^{2\pi} \int_0^{\pi/2} \text{BRDF} \cos \theta_s \sin \theta_s d\theta_s d\phi_s \quad (5)$$

BRDF is obtained with constants, VR_λ/P_i , removed from the integral. *These constants are adjusted to make ρ equal to the externally measured ρ . The constants are then returned to Eq 7 for calculation of absolute BRDF.*

6.3.4.2 A perfectly reflecting ($\rho = 1$) and diffuse sample has constant BRDF and integration of the above equation shows that it is equal to $1/\pi$. A diffuse sample will depolarize incident plane polarized light, therefore care must be exercised so that the polarization state of the light is taken into account for both the scatter and directional hemispherical reflectance measurements.

7. Procedure

7.1 Sample cleanliness can be a significant factor in the scatter level. The user should adopt a procedure for cleaning samples prior to measurement and this cleaning procedure should be reported with the BRDF results.

7.2 Correct alignment of the source, sample, and receiver are essential for accurate BRDF measurements. A typical example of a subtle error that can be introduced by misalignment occurs when the receiver does not rotate in θ_s about the sample face. *The receiver field-of-view will “walk off” the illuminated area, A , and the measured BRDF is then lower than actual BRDF as θ_s increases. Although it is not necessary to perform a total system alignment every day, alignment must be verified on a daily basis for movable components.*

7.3 After cleaning the sample and verification of alignment, the sample is inserted in the sample holder. The detector voltage, V_s , and the source monitor voltage, V_{sm} , are recorded for each parameter set of interest. *For example, BRDF measured in the plane-of-incidence requires changing θ_s while holding other parameters constant. The measurement results consist of three columns of data for θ_s , V_s , V_{sm} . The constant parameters, θ_i and ϕ_s , are retained in the header information for this data set. Post processing is used to calculate BRDF and express the results in the desired tabular or graphical format, but we can calculate P_s at this time. In this calculation, the ratio of source monitor voltages is included to correct for variation of source intensity.*

$$P_s = V_s R_\lambda V_{sm} / V_{sm} \quad (6)$$

7.4 BRDF can exhibit strong sensitivity to azimuthal orientation, spot size and position changes on the sample face. Good operating practice dictates checking for sensitivity to these and other system parameters.

8. Calculation

8.1 The BRDF of an unknown sample is calculated at each incident and scattered direction from the following relationship:

$$\text{BRDF} = P_s/P_i \Omega \cos \theta_s = (V/V)[V_s R \lambda / P_i \Omega \cos \theta_s] \text{sr}^{-1} \quad (7)$$

The value of P_i is determined by the normalization method used. The correct angular variables may also be calculated in post processing with BRDF. In all cases θ_i and θ_s are referenced to the sample normal.

8.2 Many facilities prefer to store only raw data and calculate BRDF and display variables as required to produce a graph or data table. If data are sent to another facility, it is essential to convert to BRDF and the angular variables defined in this practice. A recommended reporting format is given in Appendix X3.

9. Report

9.1 BRDF data is expressed in tabular or graphical format as a function of the variable parameter. It is necessary to state the accuracy of angular measurements and the size of the receiver solid angle, Ω . These latter parameters are important for small angle scatter. It is usually meaningless to measure within 1° of specular or to measure very narrow “diffraction spikes” when Ω spans several degrees.

9.2 It is necessary to furnish the instrument signature with the sample BRDF data so that the user can make an informed decision about the angle where the sample’s scatter becomes lost in the signature. Correct comparison of the signature with BRDF data requires multiplying the signature by the sample’s specular reflectance for that portion of the signature due to instrument scattered stray light (usually the case for θ_s near specular). The portion of the signature due to electronic noise is not reduced by the sample reflectance.

9.3 It is necessary to furnish the normalization method with BRDF data. If a relative normalization is used the source of the reference sample BRDF must be stated.

9.4 BRDF data can span many decades so it is usually expressed in base ten exponential form or plotted on a logarithmic scale.

9.5 Appendix X3 provides a reporting format recommended for use. This format is general in nature and allows for variation of any sample or system parameters.

10. Precision and Bias

10.1 *Precision*—The precision of this practice is inconclusive based on the results of an interlaboratory round robin conducted in 1988 (6). This round robin was conducted at a single wavelength (0.6328 μm), angle of incidence (10°), polarization state (s incident) and with four specific sample surfaces. It was found that precision depends on the BRDF level and scatter angle as discussed in Ref (7). Additional information on precision was accumulated in a 10.6- μm round robin conducted in 1989 (8).

10.1.1 A white diffuse sample with mean BRDF = 0.27/sr gave a fractional deviation (standard deviation of the 18 measurement sets divided by the mean BRDF) close to 17 % at scatter angles from 15° to 70° . A black diffuse sample with mean BRDF = 0.01/sr gave fractional deviations from 24 to 39 % depending on scatter angle. Specular mirrors gave fractional deviations from 31 to 134 % depending on scatter angle. Variations were larger at large scatter angles where detector noise levels of some instruments and errors in θ_s had a large effect. These variations are much larger than expected from a typical error analysis.

10.2 *Bias*—There is no bias inherent in this practice. BRDF is a number derived from the ratio of physical parameters that can be specified in absolute units. However, individual laboratories may have measurement errors that lead to systematic offsets, such as an inaccurately measured solid angle. Other possible mechanisms are discussed in Ref. (7). It is not possible at this time to separate these systematic errors from bias; however, intralaboratory measurements on the same instrument typically repeat within 5 % Ref (5).

11. Keywords

11.1 bidirectional reflectance distribution function (BRDF); diffuse; irradiance; power spectrum; radiance; reflectance; reflectance factor; roughness; scatter; specular; total integrated scatter

ANNEX

(Mandatory Information)

A1. GEOMETRY

A1.1 — *Relationship Between the Sample (X, Y, Z) and Beam (XB, YB, ZB) Coordinate Systems*—The Z and ZB axes are always the local normal to the sample face. Locations on the sample face are measured in the sample coordinate system. The incident and scatter directions are measured in the beam coordinate system. If the sample fiducial mark is not an X axis mark, the intended value must be indicated on the sample.

A1.2 *Angle Conventions for the Incident and Scattered Light in the Beam Coordinate System*—The projection of the incident direction onto the sample face is the – XB axis.

Azimuth angles are measured from the XB axis. The incident azimuth angle, ϕ_i , is always 180° so ϕ_s can be used directly in the common form of the grating equation.

A1.3 *The Receiver Geometry*—In many cases the field stop is set by the detector size; however, as the aperture stop approaches the field stop the risk of seeing unwanted stray light increases. Other receiver geometries may be used. They all have effective aperture and field stops and it is good operating practice to make them well defined.

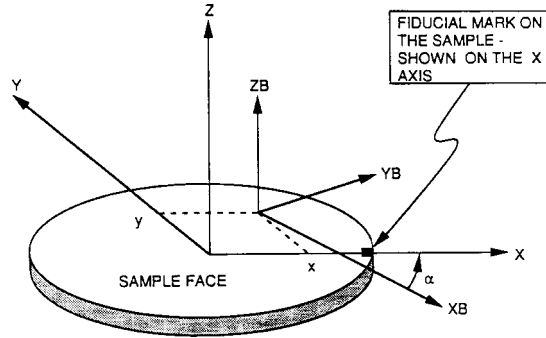

NOTE 1—The X-Y zero position on the sample face is assumed to be the geometric center of the sample.

NOTE 2—The fiducial mark can be on the edge or back of the sample.

FIG. A1.1 Relationship Between Sample and Beam Coordinate Systems

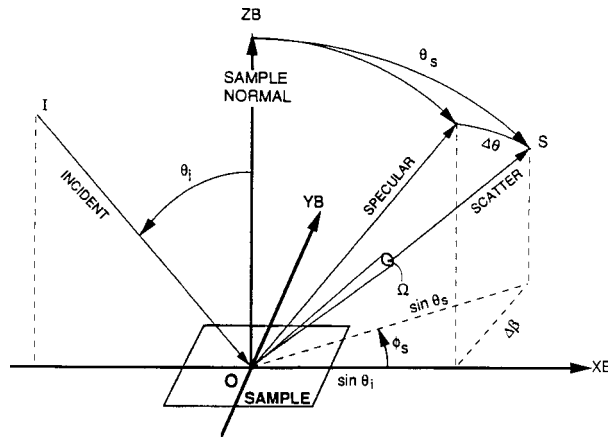

NOTE 1—The PLIN is the I-O-ZB plane. The scatter plane is the S-O-ZB plane.

FIG. A1.2 Angle Conventions

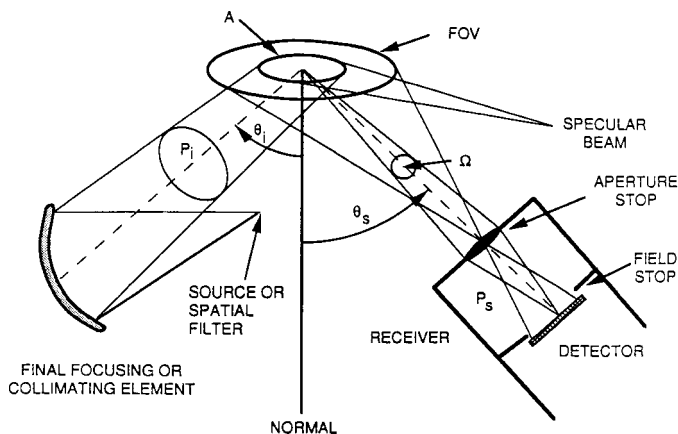

NOTE 1— A = illuminated area with average $E = P_i/A$, FOV = field of view that must include all area, A , Aperture Stop, limits; Ω , and Field Stop; limits FOV .

FIG. A1.3 Receiver Geometry

APPENDIXES

(Nonmandatory Information)

X1. ADDITIONAL DATA PRESENTATIONS

X1.1 $\Delta\theta$ Presentation—It is common practice to plot BRDF with respect to the angle from the specular beam, $\Delta\theta$. If scatter is measured only in the PLIN, $\Delta\theta = \theta_s - \theta_i$. However, in the more general case for scatter out of the PLIN:

$$\Delta\theta = \cos^{-1}(\cos \theta_i \cos \theta_s + \sin \theta_i \sin \theta_s \cos \phi_s) \quad (X1.1)$$

This is a useful angular reference for specular samples. However, when using this format care must be taken that $\Delta\theta$ is not confused with θ_s in the calculation of BRDF. This presentation format is normally used only when $\Delta\theta$ passes through zero, that is, when the scatter scan includes the specular beam. The terms “forward scatter” and “back scatter” refer to PLIN scatter directions for which $\Delta\theta$ is respectively positive or negative. Note that $\Delta\theta$ continues to increase as a negative angle when passing the surface normal since the sign of ϕ_s switches in the above equation.

X1.2 $\Delta\beta$ Presentation— $\Delta\beta = \beta - \beta_o$, where $\beta = \sin \theta_s$ and $\beta_o = \sin \theta_i$, a method of expressing the angle between the specular and scatter directions in direction cosine space along the surface for scatter in the PLIN. This is a very useful normalization when scatter results only from surface microroughness, and the grating equation:

$$\sin \theta_s = \sin \theta_i \pm n\lambda f \quad (X1.2)$$

where:

- λ = wavelength of the incident flux,
- f = linear spatial frequency for the microroughness in the x or y direction, and
- n = diffraction order.

This equation can be used to relate θ_s to f . Only the first order ($n = 1$) is significant for roughness \ll the wavelength. BRDF can now be interpreted as the ability of each f to scatter light. If BRDF is plotted versus a $\Delta\beta$ scale it may be independent of θ_i and proportional to f . If the surface behaves in this way the BRDF is “shift invariant” (9). In the general case for scatter out of the PLIN the following two dimensional grating equations apply:

$$\cos \phi_s \sin \theta_s = \sin \theta_i \pm n\lambda f_x \quad (X1.3)$$

$$\sin \theta_s \sin \theta_s = \pm n\lambda f_y \quad (X1.4)$$

The definition of $\Delta\beta$ must be expanded to include the projection of the scattered light in the X and Y directions:

$$\Delta\beta^2 = \sin^2 \theta_i + \sin^2 \theta_s - 2 \sin \theta_i \cdot \sin \theta_s \cdot \cos \theta_s \quad (X1.5)$$

X1.3 Reflectance Factor—A measure of diffuse reflectance in common use is the reflectance factor, R , that is the ratio of flux propagated from source to receiver in a reflectometer with a specimen, to the flux propagated with a perfectly reflecting diffuser. Regarding a scatterometer as a very directional bi-directional reflectometer the following relationship between R and BRDF is obtained as follows:

$$R = \frac{BRDF}{BRDF_{diffuser}} = \frac{BRDF}{1/\pi} = \pi BRDF \quad (X1.6)$$

Additional information can be found in Practice E 167. Reflectance factor and specular reflectance share the same symbol, R , but they are not the same parameter.

X2. MODEL DEPENDENT CALCULATED PARAMETERS

X2.1 *Total Integrated Scatter (TIS)*—TIS can be calculated from BRDF by integrating BRDF over the hemisphere (10). Typically a 5° total angle “hole” is left around the specular beam since specular light is not included in total integrated scatter (see Test Method F 1048).

X2.1.1 For an isotropic surface we can measure in-plane BRDF at $\theta_i = 0$ and calculate the expected total integrated scatter by integrating over the angle limits specified in Test Method F 1048.

$$TIS \text{ (calculated)} = 2\pi R^{-1} 70^{\circ} 2.5^{\circ} \cos \theta_s \text{ BRDF} \sin \theta_s d\theta_s \quad (\text{X2.1})$$

X2.1.2 Sample specular reflectance, R , must be included, since total integrated scatter is referenced to reflected and not incident power. The $\cos \theta_s$ term must be included since BRDF is defined in terms of the projected receiver aperture. This comparison between total integrated scatter and BRDF may not be exact since the total integrated scatter detector is less sensitive to light incident on the detector at large angles and if low f (close to specular) scatter dominates the 5° hole size is critical. In addition a TIS instrument is not polarization selective.

X2.2 *Roughness*—The r/min surface roughness, σ , is an often quoted number that can be obtained from direct profile measurements with stylus or optical profilometers. It can also be inferred from total integrated scatter when, $\sigma \ll \lambda/4\pi$ for front surface scatter from a clean, smooth surface (11), as described in Test Method F 1048.

$$\sigma = (\lambda/4\pi)(TIS)^{1/2} \quad (\text{X2.2})$$

X3. REPORTING FORMAT

X3.1 There is a considerable amount of information that should accompany BRDF measurements. This recommended data file format divides the information into descriptive headers followed by a data sequence of variables. The headers consist of laboratory information, system information, sample information and measurement parameters. These are simply generic labels that help to organize the fields under the headers. Any of the header fields can be a variable in the data sequence; however, variables are normally limited to measurement parameters.

X3.2 The data files are stored as ASCII text fields. Each set of data taken is stored as a separate data file. Each field in the headers and each data point in the data sequence will begin on a new line (carriage return—line feed pair terminates each line). Multiple items under each field in the headers and multiple variables per data point field in the data sequence are separated by commas. Each field in the headers will have a unique one word name preceding the field contents on the same line. This name identifies the contents of the field. The first character of a name must be an alpha character.

X2.2.1 The user must confirm the usefulness of this σ calculation based on the particular measurement circumstances. It may have strong frequency limitations and not agree with surface roughness derived from optical or mechanical profile instruments (which can have different spatial frequency limits (12)).

X2.3 *Power Spectrum*—The surface power spectral density function (PSD) can be calculated from the BRDF through a scatter model. For example, the grating equation model discussed in Appendix X1.2 shows that high frequency surface perturbations will scatter light far from specular and low frequency perturbations will scatter close to specular. The PSD shows the amount of modulation versus f , that is, the square of the Fourier transform of the surface profile. Since it is a sample property, the same PSD should be obtained regardless of wavelength and incident angle dependent differences in the BRDF data.

X2.3.1 Wavelength scaling is another check on system calibration. Smooth, clean, nonabsorbing front surface reflectors should yield the same PSD for different BRDF measurement wavelengths. If the instrument does not wavelength scale on appropriate samples, the BRDF measurement may be suspect. Polished molybdenum and silicon wafers are two examples of surfaces that have been shown to wavelength scale from the visible into the infrared. Many beryllium mirrors and silicon carbide mirrors have been shown to not wavelength scale because of anomalous scatter that arises from features other than surface roughness.

X3.3 The data sequence must come at the end of the file. Each line in the data sequence represents a single data point. It must begin with a numeric character or the +, - character. Multiple variables for each data point are on the same line but separated by commas. This permits the data sequence to be printed as a set of columns. Each variable must remain in the same column throughout a file. The VARS field specifies which variable is in each column.

X3.4 Because of the name tag, there is no position dependence for information in the headers. The number of header fields can vary from one data file to another. If a certain field is not in the file it means that information was not recorded or does not apply to that measurement. Every user should supply a format template for their header and data sequence. This will expedite conversion from site to site and avoid confusion over units and field size. Fields can easily be added to the headers if sufficient descriptive text is provided in the field or on the template. Fields can be added or deleted from old data sets without obsoleting the data file. This is a suggested list of fields in a recommended grouping and order. Additional fields will be defined by users and as they become



accepted by the scatter community they can be added to this practice.

<hr/>	
LABORATORY INFORMATION	
<hr/>	
LAB_NAME	text field with the name of the facility
LAB_ADD	street address of the facility
LAB_CITY	city the facility is located in
LAB_STATE	state the facility is located in
LAB_ZIP	zip code
LAB_PHONE	phone number of the laboratory
LAB_OPERATOR	name of the operator
LAB_COMMENTS	comments that pertain to the laboratory in open format
<hr/>	
SYSTEM INFORMATION	
<hr/>	
SYSTEM_NAME	name of the instrument the data was measured with; many facilities have more than one scatter instrument
SOURCE_KW	key words describing the source assembly such as laser, coherent, broad band, blackbody, or vendor
RX_KW	key words describing the receiver assembly such as cooled, silicon, array, HgCdTe
APERTURE	text field that describes the type of receiver aperture (circular, slit, bow tie, other)
NORM	normalization method—absolute (<i>A</i>), relative BRDF (<i>R</i>), relative specular reflectance (<i>S</i>), relative total reflectance (<i>T</i>)
FILE_REF	name/number/id of the file that contains the reference sample information for the instrument and this measurement
FILE_SIG	name/number/id of the file that contains the signature information for the instrument and this measurement
NEBRDF	noise equivalent BRDF of the instrument
ERROR	error levels expected in the BRDF measurement
SYSTEM_COMMENTS	comments that pertain to the system, for example, the type of normalization used
<hr/>	
SAMPLE INFORMATION	
<hr/>	
SAMPLE_NAME	name or id number of the sample
SAMPLE_TYPE	type of sample such as mirror, lens, window, grating, baffle substrate, paper
SAMPLE_VEND	name of the sample vendor
SAMPLE_ADD	street address of the sample vendor
SAMPLE_CITY	city of the sample vendor
SAMPLE_STATE	state of the sample vendor
SAMPLE_ZIP	zip code of the sample vendor
SAMPLE_PHONE	phone number of the sample vendor
SAMPLE_CONTACT	name of a contact person for the sample
SAMPLE_KW	key words describing the sample such as silver, black, diffuse, grating, specular, one-dimensional, two-dimensional, color
MANUF_KW	key words describing the manufacturing process of the sample such as molded, polished, ground, diamond-turned, crystal
TREAT_KW	key words describing the treatment process of the sample such as cleaned, radiated, e-beam, dust, contaminated
SHAPE_KW	key words describing the shape of the sample such as flat, square, circular, spherical, hemisphere, ellipse, irregular
FS_AREA	surface area of the front surface of the sample
SIZE_DIM	diameter or the sample
SIZE_X	size of the sample at the sample center from edge to edge in the x dimension
SIZE_Y	size of the sample at the sample center from edge to edge in the y dimension
SIZE_Z	thickness of the sample at the sample center
SUB_MAT	sample substrate material
SUB_N	substrate index of refraction, <i>n</i>
SUB_K	substrate extinction coefficient, <i>k</i>
FS_FINISH_KW	key words describing sample front surface finish such as coated, superpolish, hardened, ground, irradiated, smooth, rough
BS_FINISH_KW	key words describing the sample back surface finish
FS_CURV	the inverse of the radius of curvature of the sample front surface, convex is positive, concave is negative
BS_CURV	the inverse of the radius of curvature of the sample back surface
FS_COAT	description of the coating on the front surface
FS_SPEC_REFL	specular reflectance of the sample front surface
FS_SPEC_TRAN	specular transmittance of the sample when the front surface is incident
FS_DIFF_REFL	total hemispherical reflectance of the sample front surface
FS_DIFF_TRAN	total hemispherical transmittance of the sample when the front surface is incident
CLEAN	description of the cleaning procedure
SAMPLE_COMMENTS	comments that pertain to the sample
<hr/>	
MEASUREMENT PARAMETERS	
<hr/>	
MEAS_NAME	a descriptive name for the measurement



FILE_NAME	name/number/id of this data file
MEAS_DATE	date the measurement was made, mm-dd-yyyy
MEAS_TIME	time the measurement finished, hh:mm:ss, 24 h format
MODE	indicates whether the sample was measured in a reflective (R), transmissive (T) or both (B) mode or is a signature (S), Values are R, T, B, S
NUM_AVE	the number of measurements averaged for each data point in the data sequence
NUM_POINTS	the number of data points in the data sequence, this is a mandatory field
VARS	list of the field names for the variables that will appear in the data sequence, the entry after each of these fields in the headers will be var1, var2, var3, etc. depending on the position (column) in the data sequence
BRDF	BRDF of the sample, this is normally var1
WAVELENGTH	center wavelength of the source, units are μm
BANDWIDTH	bandwidth of the source, FWHM
ALPHA	the sample x axis position as measured from the incident plane or XB axis in degrees
THETA_I	angle of incidence, θ_i
PHI_I	incident azimuthal angle, ϕ_i
THETA_S	polar angle from sample normal, θ_s
PHI_S	scatter azimuthal angle, ϕ_s
POWER_INC	total incident power on sample in watts
POWER_SCTR	scattered power from the sample in watts
SPOT_SIZE	illuminated spot size, A, on the sample defined by the exp^{-2} power points
SOURCE_POL_I	I component of the stokes vector defining the source polarization
SOURCE_POL_M	M component of the stokes vector defining the source polarization
SOURCE_POL_C	C component of the stokes vector defining the source polarization
SOURCE_POL_S	S component of the stokes vector defining the source polarization
RX_POL_I	I component of the stokes vector defining the receiver polarization selection
RX_POL_M	M component of the stokes vector defining the receiver polarization selection
RX_POL_C	C component of the stokes vector defining the receiver polarization selection
RX_POL_S	S component of the stokes vector defining the receiver polarization selection
SOURCE_POL_ORN	the angular orientation of linear polarization for the source light wrt the PLIN, $p = 0^\circ$, $s = 90^\circ$, in degrees from 0 to 90°
RX_POL_ORN	the angular orientation of a linear polarizer in the receiver wrt the scatter plane, $P = 0^\circ$, $S = 90^\circ$, in degrees from 0 to 90°
RX_DIST	rotational radius of the aperture stop defining the solid angle for the BRDF calculation
APER_SIZE	size of the aperture stop, this is the width of a slit or the diameter of a circular aperture or the area of a bow tie or other type of complex aperture
RX_FOV	receiver FOV in steradians
SAMPLE_TEMP	sample temperature in degrees K
SAMPLE_ATM_KW	key words that describe the test atmosphere surrounding the sample during the measurement such as vacuum, air, vapor, chemical
SAMPLE_PRES	pressure of the gas surrounding the sample in torr
SAMPLE_HUMID	humidity of the gas surrounding the sample in percent
SOURCE_CONV	the source convergence or divergence at the sample in radians, convergence is positive and divergence is negative
SPOT_X	illuminated spot position in the X direction with respect to sample center
SPOT_Y	illuminated spot position in the Y direction with respect to sample center
SPOT_Z	sample front surface location with respect to the center of rotation of the instrument. A sample mounted so the front surface was the surface inspected would have a value of 0.0. A sample mounted so the back surface was the surface inspected such as a back surface reflector would have a value equal to the sample thickness
MEAS_COMMENTS	comments that pertain to the measurement
DATA_SEQUENCE	This section of the data file is a list of all data for the measurement. Each data point is stored on a separate line ending in a carriage return—line feed pair. Separate variables in the line are delimited with commas. There is no imposed limit to the number of variables in the line. Variables that do not change from the data point to the next do not have to be repeated, but two commas are needed to reserve the column.

REFERENCES

- (1) Nicodemus, Fred E., "Directional Reflectance and Emissivity of an Opaque Object," *Applied Optics*, Vol 4, 1965, p. 767.
- (2) Nicodemus, F. E., Richmond, J. C., and Hsia, J. J., "Geometrical Considerations and Nomenclature for Reflectance," *NBS Monograph 160*, 1977.
- (3) Smith, Sheldon M., "Reflectance of AMES 24E, Infrablack and Martin Black," *Proceedings*, Society of Photo-Optical Instrumentation Engineers (SPIE) 967, 1988, p. 251.
- (4) Hsia, J. J. and Richmond, J. C., "A High Resolution Laser Bidirectional Reflectometer with Results on Several Optical Coatings," *Journal of Research of the NBS-A. Physics and Chemistry*, Vol 80A, 1976, pp. 189-205.
- (5) Bjork, D. R., Rifkin, J., and Cady, F. M., "BRDF Error Analysis," *Proceedings*, SPIE 1165, 1989.
- (6) Leonard, Thomas A. and Pantoliano, Michael, "BRDF Round Robin," *Proceedings*, SPIE 967, p. 226, 1988.
- (7) Leonard, Thomas A., "The Art of Optical Scatter Measurement," *Proceedings, Laser Induced Damage in Optical Materials: 1988 Symposium*, Special Publication 775, National Institute of Standards and Technology, 1998.
- (8) Leonard, Thomas A., Pantoliano, Michael, and Reilly, James, "Results of a CO₂ BRDF Round Robin," *Proceedings*, SPIE 1165, 1989.
- (9) Harvey, James E., "Light Scattering Characteristics of Optical Surfaces," *Proceedings*, SPIE 107, 1977, p. 41.
- (10) Stover, John C., Hourmand, Bahram, and Kahler, Jeffrey, A., "Comparison of Roughness Measurements by Differential Scatter and Total Integrated Scatter," *Proceedings*, SPIE 511, 1984.
- (11) Stover, John C., *Optical Scattering: Measurement and Analysis*, 2nd



Edition, SPIE Optical Engineering Press, Bellingham, WA, 1995,
Chapter 4.

(12) Bennet, Jean M. and Mattsson, Lars, *Introduction to Surface Rough-*

ness and Scattering, Optical Society of America, Washington, DC
1989, p. 32.

ASTM International takes no position respecting the validity of any patent rights asserted in connection with any item mentioned in this standard. Users of this standard are expressly advised that determination of the validity of any such patent rights, and the risk of infringement of such rights, are entirely their own responsibility.

This standard is subject to revision at any time by the responsible technical committee and must be reviewed every five years and if not revised, either reapproved or withdrawn. Your comments are invited either for revision of this standard or for additional standards and should be addressed to ASTM International Headquarters. Your comments will receive careful consideration at a meeting of the responsible technical committee, which you may attend. If you feel that your comments have not received a fair hearing you should make your views known to the ASTM Committee on Standards, at the address shown below.

This standard is copyrighted by ASTM International, 100 Barr Harbor Drive, PO Box C700, West Conshohocken, PA 19428-2959, United States. Individual reprints (single or multiple copies) of this standard may be obtained by contacting ASTM at the above address or at 610-832-9585 (phone), 610-832-9555 (fax), or service@astm.org (e-mail); or through the ASTM website (www.astm.org).