



## Standard Specification for Semiconductor Device Passivation Opening Layouts<sup>1</sup>

This standard is issued under the fixed designation F 1211; the number immediately following the designation indicates the year of original adoption or, in the case of revision, the year of last revision. A number in parentheses indicates the year of last reapproval. A superscript epsilon (ε) indicates an editorial change since the last revision or reapproval.

<sup>ε1</sup> NOTE—Keywords were added editorially in September 1994.

### 1. Scope

1.1 This specification covers standard semiconductor device passivation opening layouts for various tape automated bonding interconnection technologies.

1.2 This specification established the nominal passivation opening dimensions, nominal passivation, opening spacing, nominal corner passivation opening offset, minimum scribe guard and minimum die size for the most common input/output counts within each technology.

1.3 This specification is extendable to other interconnection technologies if the passivation opening and spacing are adjusted in such a way that the progression is not modified.

1.4 The values stated in SI units are to be regarded as the standard. The values given in parentheses are for information only.

### 2. Terminology

#### 2.1 Definitions:

2.1.1 *corner offset*—The orthogonal distance between the corner passivation opening on adjacent sides of the die where a corner passivation opening is indentified as the end passivation opening on a die side.

2.1.2 *lead count*—The number of passivation openings available on a fully populated die layout.

2.1.3 *minimum die edge guard*—The minimum distance between the die edge and the passivation opening nearest to the die edge herein used to establish the minimum die size.

2.1.4 *minimum die size*—The minimum die size is calculated by the following equation:

$$\begin{aligned} \text{minimum die size} = & ((\text{lead count}/4) (\text{p.o. size} + \text{p.o. space})) \\ & - \text{p.o. space} + (2 (\text{corner offset} + \text{p.o. size} \\ & + \text{die edge guard})) \end{aligned}$$

2.1.5 *passivation opening*—The unpassivated area within

the device metal bonding pad area.

2.1.6 *passivation opening size*—The minimum orthogonal dimensions of the passivation opening for the particular technology herein used as the nominal passivation opening size.

2.1.7 *passivation opening space*—The minimum space between adjacent passivation openings for the particular technology herein used as the nominal passivation opening spacing.

2.1.8 *progression*—The dimension as measured from a reference point on one passivation opening to the same reference point on the adjacent passivation opening.

2.1.9 *technology*—The minimum passivation opening progression allowable for a specific interconnection method.

### 3. Classification

3.1 The passivation opening layouts are separated into four technology types where:

Type I = 220 μm technology (220 μm = 8.7 mils)

Type II = 185 μm technology (185 μm = 7.3 mils)

Type III = 150 μm technology (150 μm = 5.9 mils)

Type IV = 100 μm technology (100 μm = 3.9 mils)

### 4. Dimensions, Mass, and Permissible Variations

4.1 The primary unit of measure is micrometres (μm) (1 micrometre = 1 micron) and the secondary unit of measure is mils (1/1000 of an in.), where 1 mil (0.001 in.) = 25.4 μm.

4.2 Fig. 1 shows the generic dimension measurement for each defined dimension.

4.3 The lead count independent dimensions are summarized in Table 1 for all technologies.

4.4 The specific standard layouts are listed in Tables 2-5 for Type I, Type II, Type III and Type IV technologies respectively.

4.5 *Progression*—Any variations must be noncumulative.

4.6 *Lead Count*—All passivation openings as specified in this specification must be included in the design whether they are or are not connected internally.

### 5. Keywords

5.1 opening layouts; passivation; semiconductor devices

<sup>1</sup> This specification is under the jurisdiction of ASTM Committee F-1 on Electronic and is the direct responsibility of Subcommittee F01.16 on Tape Automated Bonding.

Current edition approved Feb. 24, 1989. Published April 1989.

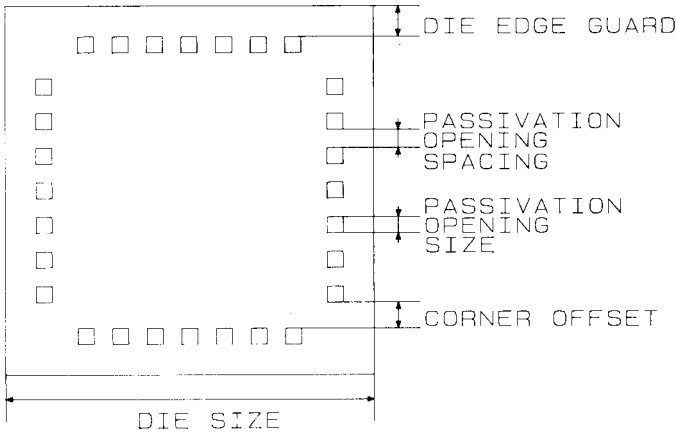

FIG. 1 Generic Dimension Measurement

TABLE 1 Generic Dimensions for the Various Technologies

Technology, $\mu\text{m}$ (mil)	Passivation Opening Size, $\mu\text{m}$ (mil)	Passivation Opening Space, $\mu\text{m}$ (mil)	Corner Offset, $\mu\text{m}$ (mil)	Die Edge Guard, $\mu\text{m}$ (mil)
220 (8.7)	100 (3.94)	120 (4.72)	82 (3.23)	131 (5.16)
185 (7.3)	80 (3.14)	105 (4.13)	188 (7.40)	125 (4.92)
150 (5.9)	70 (2.76)	80 (3.14)	112 (4.41)	110 (4.33)
100 (3.9)	40 (1.57)	60 (2.36)	82 (3.23)	110 (4.33)

TABLE 2 Specific Dimensions for the Type I (220  $\mu\text{m}$ ) Technology for Each Lead Count

Lead Count n	Passivation Opening Size, $\mu\text{m}$ (mil)	Passivation Opening Space, $\mu\text{m}$ (mil)	Corner Offset, $\mu\text{m}$ (mil)	Minimum Die Edge Guard, $\mu\text{m}$ (mil)	Minimum Die Size, $\mu\text{m}$ (mil)
28	100 (3.94)	120 (4.72)	82 (3.23)	131 (5.16)	2.1 (81)
32	100 (3.94)	120 (4.72)	82 (3.23)	131 (5.16)	2.3 (90)
40	100 (3.94)	120 (4.72)	82 (3.23)	131 (5.16)	2.8 (107)
44	100 (3.94)	120 (4.72)	82 (3.23)	131 (5.16)	3.0 (116)
68	100 (3.94)	120 (4.72)	82 (3.23)	131 (5.16)	4.3 (168)
84	100 (3.94)	120 (4.72)	82 (3.23)	131 (5.16)	5.2 (202)
100	100 (3.94)	120 (4.72)	82 (3.23)	131 (5.16)	6.1 (237)
132	100 (3.94)	120 (4.72)	82 (3.23)	131 (5.16)	7.8 (306)
144	100 (3.94)	120 (4.72)	82 (3.23)	131 (5.16)	8.5 (332)
164	100 (3.94)	120 (4.72)	82 (3.23)	131 (5.16)	9.6 (375)
180	100 (3.94)	120 (4.72)	82 (3.23)	131 (5.16)	10.5 (410)
196	100 (3.94)	120 (4.72)	82 (3.23)	131 (5.16)	11.3 (444)

TABLE 3 Specific Dimensions for the Type II (185  $\mu\text{m}$ ) Technology for Each Lead Count

Lead Count n	Passivation Opening Size, $\mu\text{m}$ (mil)	Passivation Opening Space, $\mu\text{m}$ (mil)	Corner Offset, $\mu\text{m}$ (mil)	Minimum Die Edge Guard, $\mu\text{m}$ (mil)	Minimum Die Size, $\mu\text{m}$ (mil)
28	80 (3.14)	105 (4.13)	188 (7.40)	125 (4.92)	2.0 (78)
32	80 (3.14)	105 (4.13)	188 (7.40)	125 (4.92)	2.2 (86)
40	80 (3.14)	105 (4.13)	188 (7.40)	125 (4.92)	2.6 (100)
44	80 (3.14)	105 (4.13)	188 (7.40)	125 (4.92)	2.8 (107)
68	80 (3.14)	105 (4.13)	188 (7.40)	125 (4.92)	3.9 (151)
84	80 (3.14)	105 (4.13)	188 (7.40)	125 (4.92)	4.6 (180)
100	80 (3.14)	105 (4.13)	188 (7.40)	125 (4.92)	5.4 (209)
132	80 (3.14)	105 (4.13)	188 (7.40)	125 (4.92)	6.8 (268)
144	80 (3.14)	105 (4.13)	188 (7.40)	125 (4.92)	7.4 (290)
164	80 (3.14)	105 (4.13)	188 (7.40)	125 (4.92)	8.3 (326)
180	80 (3.14)	105 (4.13)	188 (7.40)	125 (4.92)	9.1 (355)
196	80 (3.14)	105 (4.13)	188 (7.40)	125 (4.92)	9.7 (384)
220	80 (3.14)	105 (4.13)	188 (7.40)	125 (4.92)	10.9 (428)
244	80 (3.14)	105 (4.13)	188 (7.40)	125 (4.92)	12.0 (472)
260	80 (3.14)	105 (4.13)	188 (7.40)	125 (4.92)	12.8 (501)

TABLE 4 Specific Dimensions for the Type III (150  $\mu\text{m}$ ) Technology for Each Lead Count

Lead Count n	Passivation Opening Size, $\mu\text{m}$ (mil)	Passivation Opening Space, $\mu\text{m}$ (mil)	Corner Offset, $\mu\text{m}$ (mil)	Minimum Die Edge Guard, $\mu\text{m}$ (mil)	Minimum die Size, $\mu\text{m}$ (mil)
28	70 (2.76)	80 (3.14)	112 (4.41)	110 (4.33)	1.6 (62)
32	70 (2.76)	80 (3.14)	112 (4.41)	110 (4.33)	1.8 (68)
40	70 (2.76)	80 (3.14)	112 (4.41)	110 (4.33)	2.1 (79)
44	70 (2.76)	80 (3.14)	112 (4.41)	110 (4.33)	2.2 (85)
68	70 (2.76)	80 (3.14)	112 (4.41)	110 (4.33)	3.1 (121)
84	70 (2.76)	80 (3.14)	112 (4.41)	110 (4.33)	3.7 (144)
100	70 (2.76)	80 (3.14)	112 (4.41)	110 (4.33)	4.3 (168)
132	70 (2.76)	80 (3.14)	112 (4.41)	110 (4.33)	5.5 (215)
144	70 (2.76)	80 (3.14)	112 (4.41)	110 (4.33)	6.0 (233)
164	70 (2.76)	80 (3.14)	112 (4.41)	110 (4.33)	6.7 (262)
180	70 (2.76)	80 (3.14)	112 (4.41)	110 (4.33)	7.3 (286)
196	70 (2.76)	80 (3.14)	112 (4.41)	110 (4.33)	7.9 (310)
220	70 (2.76)	80 (3.14)	112 (4.41)	110 (4.33)	8.8 (345)
244	70 (2.76)	80 (3.14)	112 (4.41)	110 (4.33)	9.7 (381)
260	70 (2.76)	80 (3.14)	112 (4.41)	110 (4.33)	10.3 (404)
284	70 (2.76)	80 (3.14)	112 (4.41)	110 (4.33)	11.2 (440)
300	70 (2.76)	80 (3.14)	112 (4.41)	110 (4.33)	11.8 (463)

**TABLE 5 Specific Dimensions for the Type IV (100  $\mu\text{m}$ )  
Technology for Each Lead Count**

Lead Count n	Passivation Opening Size, $\mu\text{m}$ (mil)	Passivation Opening Space, $\mu\text{m}$ (mil)	Corner Offset, $\mu\text{m}$ (mil)	Minimum Die Edge Guard, $\mu\text{m}$ (mil)	Minimum Die Size, $\mu\text{m}$ (mil)
68	40 (1.57)	60 (2.36)	82 (3.23)	110 (4.33)	2.2 (83)
84	40 (1.57)	60 (2.36)	82 (3.23)	110 (4.33)	2.6 (99)
100	40 (1.57)	60 (2.36)	82 (3.23)	110 (4.33)	3.0 (115)
132	40 (1.57)	60 (2.36)	82 (3.23)	110 (4.33)	3.8 (146)
144	40 (1.57)	60 (2.36)	82 (3.23)	110 (4.33)	4.1 (158)
164	40 (1.57)	60 (2.36)	82 (3.23)	110 (4.33)	4.6 (178)
180	40 (1.57)	60 (2.36)	82 (3.23)	110 (4.33)	5.0 (194)
196	40 (1.57)	60 (2.36)	82 (3.23)	110 (4.33)	5.4 (209)
220	40 (1.57)	60 (2.36)	82 (3.23)	110 (4.33)	6.0 (233)
244	40 (1.57)	60 (2.36)	82 (3.23)	110 (4.33)	6.6 (257)
260	40 (1.57)	60 (2.36)	82 (3.23)	110 (4.33)	6.9 (272)
284	40 (1.57)	60 (2.36)	82 (3.23)	110 (4.33)	7.6 (296)
300	40 (1.57)	60 (2.36)	82 (3.23)	110 (4.33)	8.0 (312)
324	40 (1.57)	60 (2.36)	82 (3.23)	110 (4.33)	8.6 (335)
364	40 (1.57)	60 (2.36)	82 (3.23)	110 (4.33)	9.6 (375)
372	40 (1.57)	60 (2.36)	82 (3.23)	110 (4.33)	9.8 (383)
388	40 (1.57)	60 (2.36)	82 (3.23)	110 (4.33)	10.2 (398)
404	40 (1.57)	60 (2.36)	82 (3.23)	110 (4.33)	10.6 (414)
420	40 (1.57)	60 (2.36)	82 (3.23)	110 (4.33)	11.0 (430)

*The American Society for Testing and Materials takes no position respecting the validity of any patent rights asserted in connection with any item mentioned in this standard. Users of this standard are expressly advised that determination of the validity of any such patent rights, and the risk of infringement of such rights, are entirely their own responsibility.*

*This standard is subject to revision at any time by the responsible technical committee and must be reviewed every five years and if not revised, either reapproved or withdrawn. Your comments are invited either for revision of this standard or for additional standards and should be addressed to ASTM Headquarters. Your comments will receive careful consideration at a meeting of the responsible technical committee, which you may attend. If you feel that your comments have not received a fair hearing you should make your views known to the ASTM Committee on Standards, at the address shown below.*

*This standard is copyrighted by ASTM, 100 Barr Harbor Drive, PO Box C700, West Conshohocken, PA 19428-2959, United States. Individual reprints (single or multiple copies) of this standard may be obtained by contacting ASTM at the above address or at 610-832-9585 (phone), 610-832-9555 (fax), or service@astm.org (e-mail); or through the ASTM website (www.astm.org).*