



Standard Test Method for Measuring Dose for Use in Linear Accelerator Pulsed Radiation Effects Tests¹

This standard is issued under the fixed designation F 526; the number immediately following the designation indicates the year of original adoption or, in the case of revision, the year of last revision. A number in parentheses indicates the year of last reapproval. A superscript epsilon (ϵ) indicates an editorial change since the last revision or reapproval.

This standard has been approved for use by agencies of the Department of Defense.

1. Scope

1.1 This test method covers a calorimetric measurement of the dose delivered in a single pulse of electrons from an electron linear accelerator used as an ionizing source in radiation-effects testing. The test method is designed for use with pulses of electrons in the energy range from 10 to 50 MeV and is only valid for cases in which both the calorimeter and the test specimen to be irradiated are “thin” compared to the range of these electrons in the materials of which they are constructed.

1.2 The procedure described can be used in those cases in which (1) the dose delivered in a single pulse is 5 Gy² (500 rad) or greater, or (2) multiple pulses of a lower dose can be delivered in a time short compared to the thermal time constant of the calorimeter. The minimum dose per pulse that can be acceptably monitored depends on the variables of the particular test, including pulse rate, pulse uniformity, and the thermal time constant of the calorimeter.

1.3 A determination of the dose is made directly for the material of which the calorimeter block is made. The dose in other materials can be calculated from this measured value by formulas presented in this test method. The need for such calculations and the choice of materials for which calculations are to be made shall be subject to agreement by the parties to the test.

1.4 The values stated in SI units are to be regarded as the standard. The values in parenthesis are provided for information only.

1.5 *This standard does not purport to address the safety concerns, if any, associated with its use. It is the responsibility of the user of this standard to establish appropriate safety and health practices and determine the applicability of regulatory limitations prior to use.*

2. Referenced Documents

2.1 ASTM Standards:

E 230 Temperature Electromotive Force (EMF) Tables for Standardized Thermocouples³

3. Terminology

3.1 Definitions:

3.1.1 *thermal time constant of a calorimeter*—the time for the temperature excursion of the calorimeter resulting from a radiation pulse to drop to $1/e$ of its initial maximum value.

4. Summary of Test Method

4.1 *Single-Pulse Method*—This method consists of (1) irradiating, with a single pulse of high-energy electrons from an electron linear accelerator (linac), a small block of material to which either a thermistor or a thermocouple made from small-diameter wire is attached; (2) recording and measuring the resulting signal from a bridge circuit or directly from the thermocouple; (3) calculating the dose deposited in the block based on the temperature rise and the specific heat of the material; and (4) if required, calculating the equivalent dose in other specified materials.

4.2 *Multiple-Pulse Method*—If the dose available in a single pulse is not large enough to give measurable results, the linac is pulsed repeatedly within a time short compared to the thermal time constant of the calorimeter. This method is similar to the single-pulse method except that the average dose delivered in each pulse is calculated from the measured cumulative dose of all the pulses.

5. Significance and Use

5.1 An accurate measure of the dose during radiation-effects testing is necessary to ensure the validity of the data taken, to enable comparison to be made of data taken at different facilities, and to verify that components or circuits are tested to the radiation specification applied to the system for which they are to be used.

¹ This test method is under the jurisdiction of ASTM Committee F01 on Electronics, and is the direct responsibility of Subcommittee F01.11 on Quality and Hardness Assurance.

Current edition approved Dec. 10, 1997. Published March 1998. Originally published as F 526 – 77 T. Last previous edition F 526 – 91.

² In 1975 the General Conference on Weights and Measures adopted the unit gray (symbol—Gy) for absorbed dose; 1 Gy = 100 rad.

³ *Annual Book of ASTM Standards*, Vol 14.03.

5.2 The primary value of a calorimetric method for measuring dose is that the results are absolute. They are based only on physical properties of materials, that is, the specific heat of the calorimeter-block material and the Seebeck emf of the thermocouple used or the temperature coefficient of resistance (α) of the thermistor used, all of which can be established with non-radiation measurements.

5.3 The method permits repeated measurements to be made during a radiation effects test without requiring entry into the radiation cell between measurements.

6. Interferences

6.1 *Thermal Isolation*—If the thermal isolation of the calorimeter is not sufficient, the thermal time constant of the calorimeter response will be too short for it to be useful.

NOTE 1—This condition can be caused by insufficient insulation material or by heat loss through the thermocouple wires themselves.

6.2 *Thermal Equilibrium*—The initial value of the transient temperature change following a radiation pulse may not reflect the true temperature change of the calorimeter-block material.

NOTE 2—This situation can be brought about by a temperature rise occurring in the materials at the point of attachment of the thermocouple or the thermistor different from that in the calorimeter-block material. As long as the calorimeter block comprises the great bulk of the calorimeter material, the temperature will quickly equilibrate to that of the block, and the subsequent temperature record will be that of the calorimeter-block material (see Appendix X1).

6.3 *Pulse Reproducibility*—If pulse-to-pulse reproducibility of the radiation source varies more than $\pm 20\%$, a good measure of the dose per pulse may not be attainable from the average value calculated in the multiple-pulse method.

7. Apparatus

7.1 *Linac*—Electron linear accelerator and associated instrumentation and controls suitable for use as an ionizing source in radiation-effects testing.

7.2 *Calorimeter*—Special instrument suitable for measuring the dose delivered by the linac and constructed in accordance with any of several designs utilizing any of several materials as indicated in Appendix X1. Although measurement differences resulting from the use of different designs should not be significant, all parties to the test shall agree to a single design utilizing a single calorimeter-block material and a specific thermocouple or thermistor. The calorimeter design shall be such that the surface density in the beam path is less than or equal to no more than 20% of the range of the beam-energy electrons (see Fig. 1).

7.3 *D-C Low Noise Amplifier (LNA)*, with a gain of 1000 to 10 000 (see Fig. 2).

NOTE 3—An analog nanovoltmeter with a recorder output can also be used as a low noise amplifier. These devices produce a 1-V output for a full scale reading.

7.3.1 Response time no greater than 0.1 s for the amplifier output to reach 90% of its final reading.

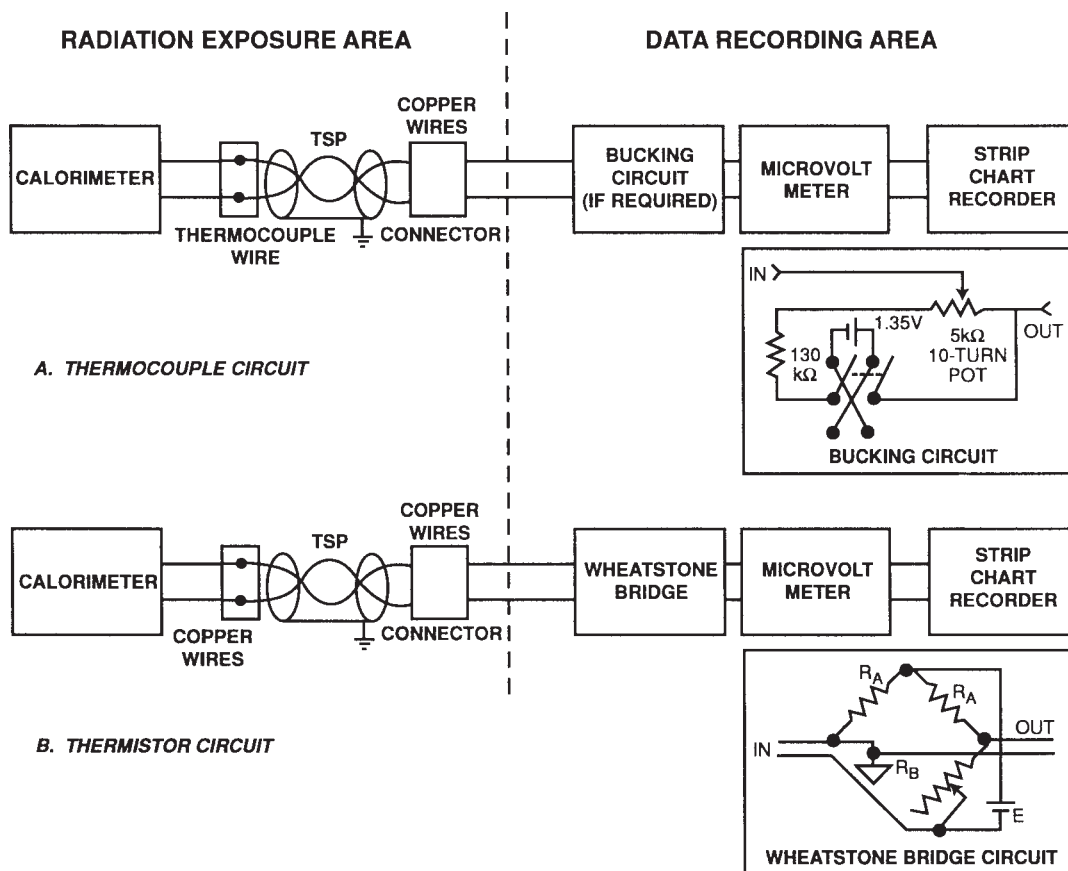
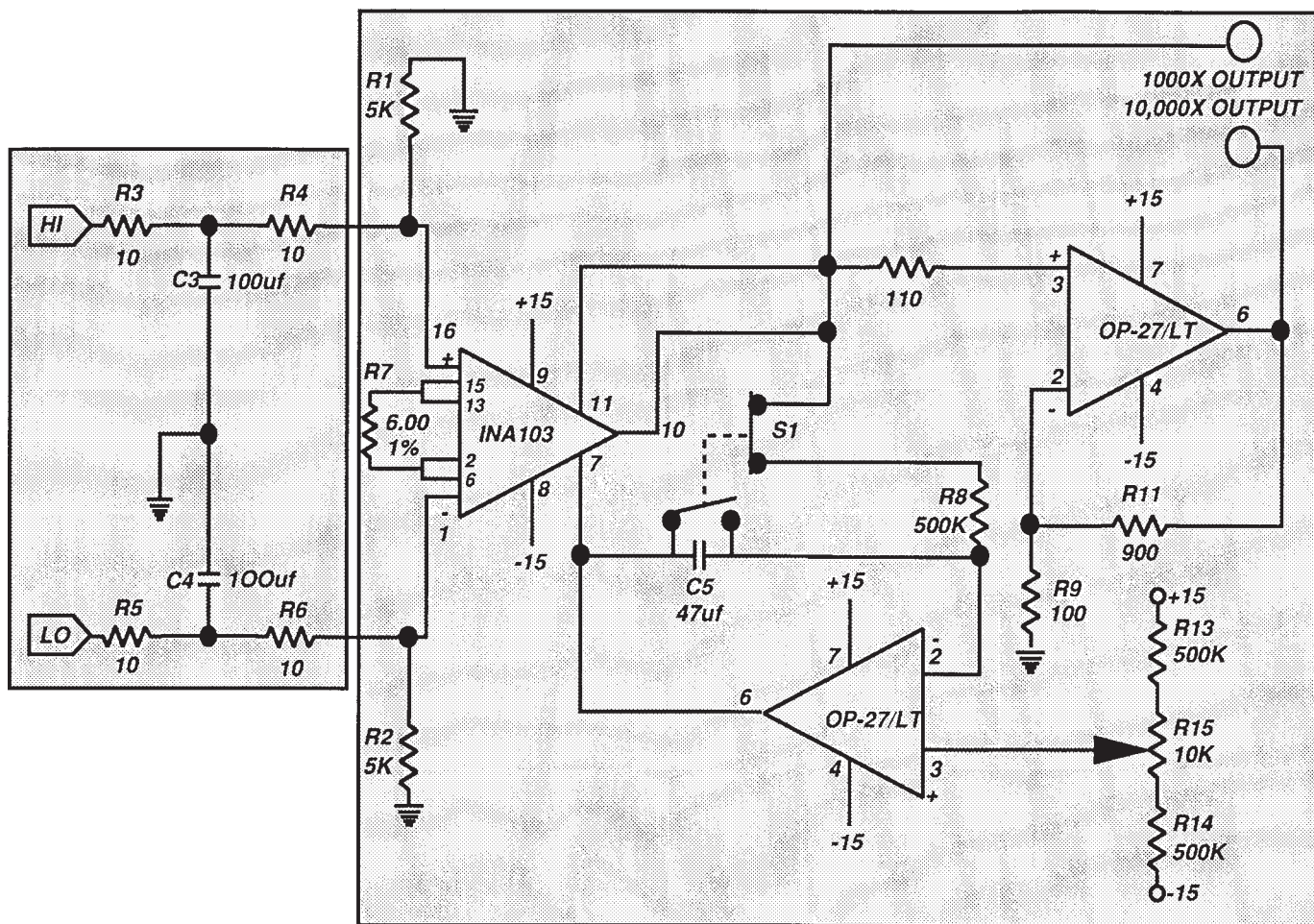

FIG. 1 Block Diagram of Calorimeter Dosimeter Circuit



S1 for Auto Zero

FIG. 2 FIG. Recommended Low Noise Amplifier Schematic Diagram

7.3.2 Noise level less than 10 mV rms referred to the output,
 7.3.3 Measurement accuracy of 2 % of full scale or better,
 and

7.3.4 Normal-mode rejection capability such that a-c voltages of 50 Hz and above and 60 dB greater than the range setting shall affect the instrument reading by less than 2 %.

NOTE 4—If the meter does not have an internal nulling circuit, it may be necessary to use a simple bucking circuit to null out thermal emfs in the measuring circuit to keep the meter on scale at the high-gain positions used in this measurement (see Fig. 1).

7.4 Data Recorder—Linear-response recorder meeting the following specifications:

7.4.1 Recording speed sufficient to capture 5 to 10 s of calorimeter response.

7.4.2 Response time for full-scale deflection of 0.1 s or less.

7.4.3 Deviation of response from linearity of no more than ± 2 %, and

7.4.4 Sensitivity compatible with the recorder output of the d-c LNA. Typically 2mV full scale.

7.5 Voltage Calibration Source—Voltage source capable of meeting the following specifications:

7.5.1 Output voltages including 1.5, 3.0, 5.0, 10.0, 15, 30, and 50 μ V, and 100 μ V,

7.5.2 Accuracy of ± 1 % of the selected voltage, or better,

7.5.3 Thermally generated voltages of less than 100 nV with the source stabilized, and

7.5.4 Source resistance of 100 Ω or less.

7.6 Wheatstone Bridge Circuit, designed so that the thermistor forms one leg of the bridge, and so that the adjustable resistor of the bridge will be equal to the resistance of the thermistor at balance (see Fig. 1B).

8. Sampling

8.1 The number of measurements shall be subject to agreement by the parties to the test.

9. Calibration

9.1 The LNA and data recorder should be calibrated to be within ± 2 % of full scale.

10. Procedure

10.1 Single-Pulse Method:

10.1.1 Position the calorimeter at the location where the dose measurement is desired.

10.1.2 Connect all components of the calorimetric dosimeter system in accordance with the circuit shown in Fig. 1.

10.1.3 Set the LNA for a gain of 10 000 (1000), if using the thermistor circuit).

10.1.4 For the thermocouple measurements, adjust either the internal nulling circuit of the LNA or the external bucking circuit so that the meter deflection caused by the quiescent level of the calorimeter output is less than full scale. For thermistor measurements adjust the bridge for a null. Use the zero-adjust capability of the data recorder to position the recorder trace near the center of the recorder chart.

NOTE 5—With either system, there will likely be a drift as the temperature of the calorimeter equilibrates. This drift is compensated for in data reduction and may be neglected if the rate of change is much less than that caused by the radiation pulse.

10.1.5 With the data recorder sweep speed set within the range from 0.5 to 2.0 cm/s, inclusive, trigger the recorder and pulse the linac.

10.1.6 If the transient deflection of the recorder is less than 10 % of full scale, set the recorder range to the next lower range and repeat 10.1.5.

10.1.7 Repeat 10.1.5 and 10.1.6 until a range is found for which the greater-than-10 % criterion is met, or until there are no more ranges to try.

10.1.7.1 When a range is found for which this greater-than-10 % criterion is met, annotate the data recorder output beside the recorded transient with the shot number, date, LNA gain, calorimeter identification, and description of irradiation geometry (including scatterer thickness and distance of the calorimeter from the scatterer) as shown in Fig. 3 and Fig. 4.

10.1.7.2 If no range is found for which a 10 % deflection is obtained which is easily distinguishable from noise, use the multiple-pulse method beginning with 10.2.2.

10.1.7.3 Otherwise, repeat 10.1.7.1 four more times.

10.2 Multiple-Pulse Method:

10.2.1 Carry out 10.1.1 through 10.1.4.

10.2.2 With the recorder chart speed set within the range from 0.5 to 2.0 cm/s, inclusive, pulse the Linac repeatedly within a time that is short compared to the thermal time constant of the calorimeter to give a recorder deflection greater than 10 % of full scale.

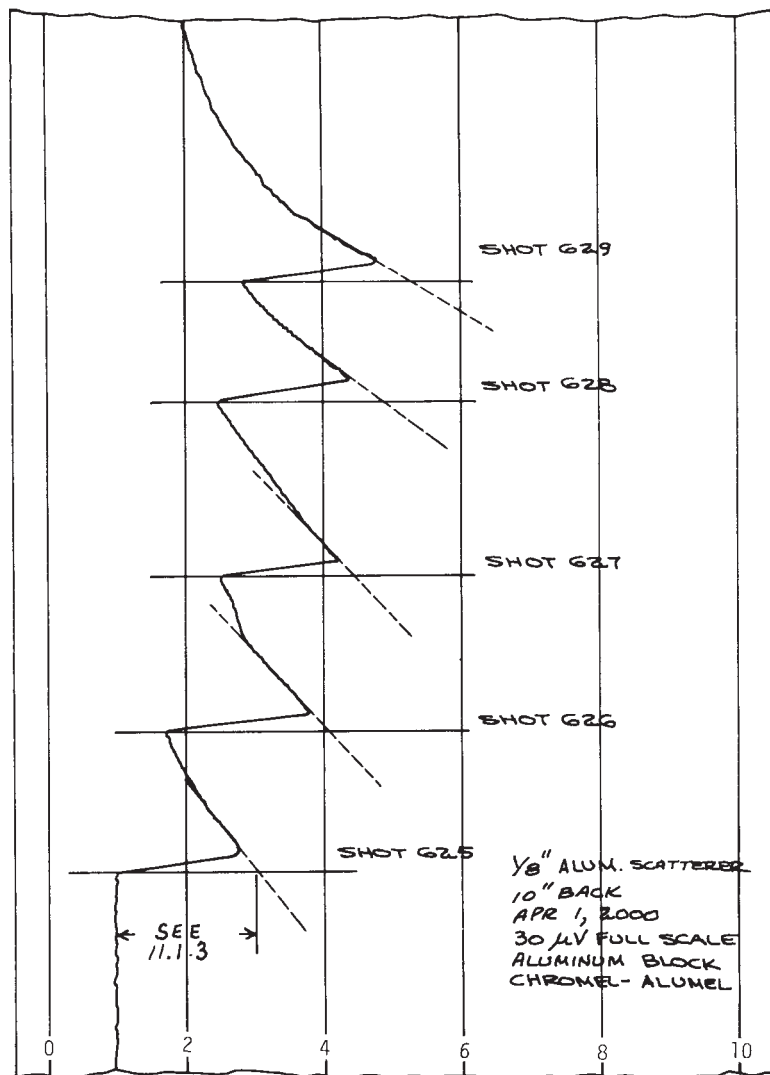

FIG. 3 Typical Chart Record of Calorimeter Dosimetry Using Single-Pulse Method

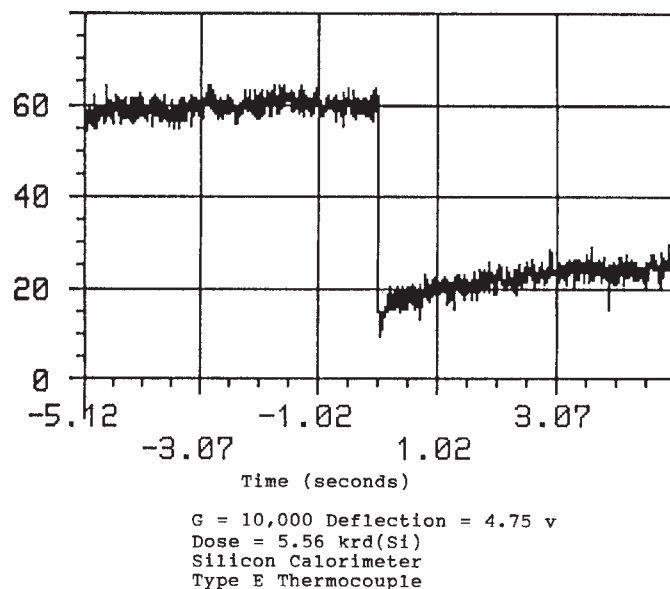

FIG. 4 Typical Digital Oscilloscope Recording of the Calorimeter Response

10.2.2.1 From the data, measure the voltage rise resulting from this series of pulses.

10.2.2.2 For the time interval beginning with the cessation of the radiation and equal in duration to the total time during which the radiation dose was accumulated, measure the thermocouple voltage drop.

10.2.2.3 Calculate the ratio of the voltage from 10.2.2.2 to that of 10.2.2.1.

10.2.2.4 If this ratio is less than 0.15, continue with 10.2.3 (the thermal time constant of the calorimeter is sufficiently greater than the radiation time for the dose to be determined accurately).

10.2.2.5 If this ratio is equal to or greater than 0.15, repeat 10.2.2 through 10.2.2.5 using a higher pulse repetition rate for a shorter radiation time period.

10.2.3 Annotate the data recorder output, as well as the number of pulses used (see Fig. 5, Fig. 6, and Fig. 7).

10.2.4 Repeat 10.2.2 and 10.2.3 four more times, omitting the time constant determination (10.2.2.1 through 10.2.2.5).

11. Calculation and Interpretation of Results

11.1 Single-Pulse Method:

11.1.1 On the recorder output, determine the perpendicular to the time axis at the start of each transient, as shown in Fig. 3.

11.1.2 Determine whether a period of time was required for the temperature to equilibrate after the pulse, as indicated by the presence of a spike (Fig. 5a) or a flat portion (Fig. 5b) of the data recorder trace at the end of the transient.

11.1.2.1 If no such feature is present, draw a line extrapolating the steepest part of the cooling curve following each radiation pulse back to intersect the perpendicular line (see 11.1.1). When using digital storage oscilloscopes, built in cursors usually can be used.

NOTE 6—These lines are dashed in Fig. 3.

11.1.2.2 If such a feature is present, draw a line extrapolat-

TABLE 1 Physical Properties of Some Calorimeter-Block Materials

Material	Energy Loss ^A dE/dx (10^{-14} J·m ² /kg)	Specific Heat, c_p ^B (J/kg·K)	Density, ρ ^B (10^3 kg/m ³)
C	2.92	711	2.10
Al	2.74	900	2.70
Si	2.84	711	2.33
Fe	2.52	452	7.87
Cu	2.42	385	8.96
Ge	2.45	322	5.32
W	2.08	134	19.3
Au	2.06	130	19.3
Pb	2.07	128	11.4

^AThe data are given for 20-MeV electrons, but ratios based on these values are good to better than 2% over the energy range from 10 to 50 MeV, inclusive. These values have been converted to SI units from data given in the tables of Berger and Seltzer: *Tables of Energy Losses and Ranges of Electrons and Positrons*, NASA SP-3012 (1964); and *Additional Stopping Powers and Range Tables for Protons, Mesons, and Electrons*, NASA SP-3036 (1966).

^BThese values have been converted to SI units from data given in the *Handbook of Tables for Applied Engineering Science*, 2nd ed., CRC Press, Cleveland, OH (1973). (The specific heat values are applicable in the range from 18 to 30°C, inclusive.)

ing from the slope of the curve where a smooth cooling trend resumes. Do this for each pulse.

NOTE 7—These lines are dashed in Fig. 5.

11.1.3 Measure along each perpendicular line the length from the start of each transient to the intersection of the perpendicular line with the extrapolated line.

11.1.4 Convert these measurements to output voltage level.

11.1.5 For each pulse calculate and record the dose in Gy (calorimeter-block material) producing the transient, using for a thermocouple measurement, the relation:

$$\text{Dose} = 100 V_{c_p} / PG \quad (1)$$

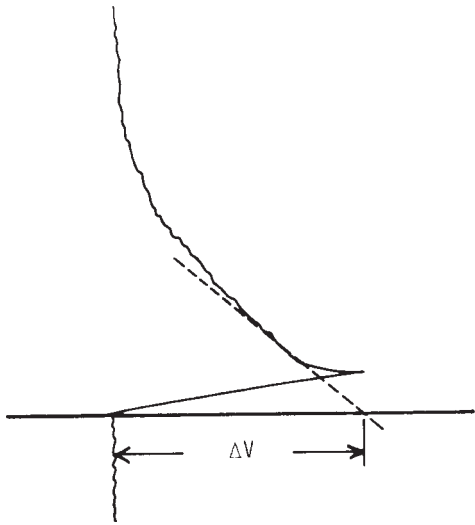

(a) Spike Indicating Initial Thermocouple Junction Temperature Higher than that of the Calorimeter Block.

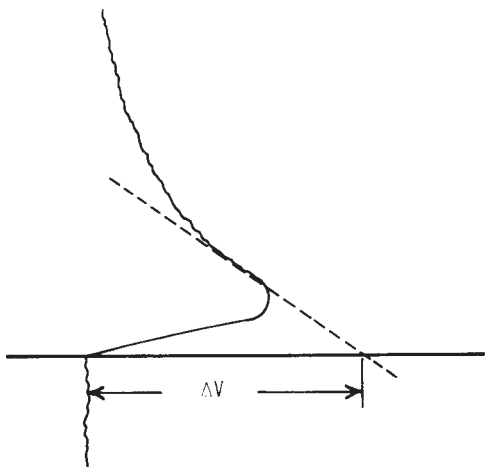

(b) Flat Portion Indicating Initial Thermocouple Junction Temperature Lower than that of the Calorimeter Block.

FIG. 5 Possible Aberrations Observed in Strip-Chart Recorder Transient Signals

where:

V = deflection caused by irradiation pulse, in micrometres,

c_p = specific heat of calorimeter-block material, J/kg·K,

\dot{P} = temperature coefficient of the calorimeter thermocouple in the vicinity of room temperature, $\mu\text{V}/\text{K}$,

G = gain of low noise amplifier, and,

100 = numerical conversion factor, rad·kg/J.

11.1.6 For a thermistor measurement, use the equation (Appendix X2):

$$\text{Dose} = \frac{(R_A + R_B)^2 k c_p}{R_A R_B \alpha E} V \quad (2)$$

where:

R_A = value of the fixed bridge resistors, Ω ,

R_B = value of the variable bridge resistor, Ω ,

k = numerical conversion constant = 10^{-2} J/kg·rad,

α = thermistor temperature coefficient of resistance, K^{-1} ,

E = bridge voltage, V, and

V and c_p have the same meaning as above.

11.1.7 Average and record the results obtained from the above calculation for each of the five radiation pulses,

11.2 Multiple-Pulse Method:

11.2.1 Draw a line perpendicular to the time axis at the time midway between the start and end of the sets of multiple radiation pulses, as shown in Fig. 6.

11.2.2 For each multiple-pulse transient, draw a linear extrapolation of the cooling curve immediately preceding the radiation, and extend it to intercept the perpendicular line (see 11.2.1).

NOTE 8—These lines are dashed in Fig. 6.

11.2.3 For each transient, draw a line extrapolating back the cooling curve, following the transient, to intercept the perpendicular line drawn for that transient.

NOTE 9—These lines are also dashed in Fig. 6.

11.2.4 For each transient, measure the length along the perpendicular line between the intersections with the extended and extrapolated lines.

11.2.5 Convert these measurements to fractions of full-scale width.

11.2.6 Calculate and record the dose delivered in each burst of multiple pulses in accordance with 11.1.5.

11.2.7 Divide the dose calculated for each set of pulses by the number of pulses in the set to obtain the average dose per pulse for that set. Record these figures.

11.2.8 Average the five values obtained. Record this figure.

NOTE 10—This figure provides the best estimate of the average dose per pulse. However, this average value is seldom useful if the pulse-to-pulse reproducibility is not within $\pm 20\%$ of a median value.

11.3 Dose Conversion:

11.3.1 To convert the dose measured in 11.1 or 11.2 to dose in a material other than that of the calorimeter block, use the equation:

$$\text{Dose B} = \frac{dE / dx_{(B)}}{dE / dx_{(A)}} \text{Dose A} \quad (3)$$

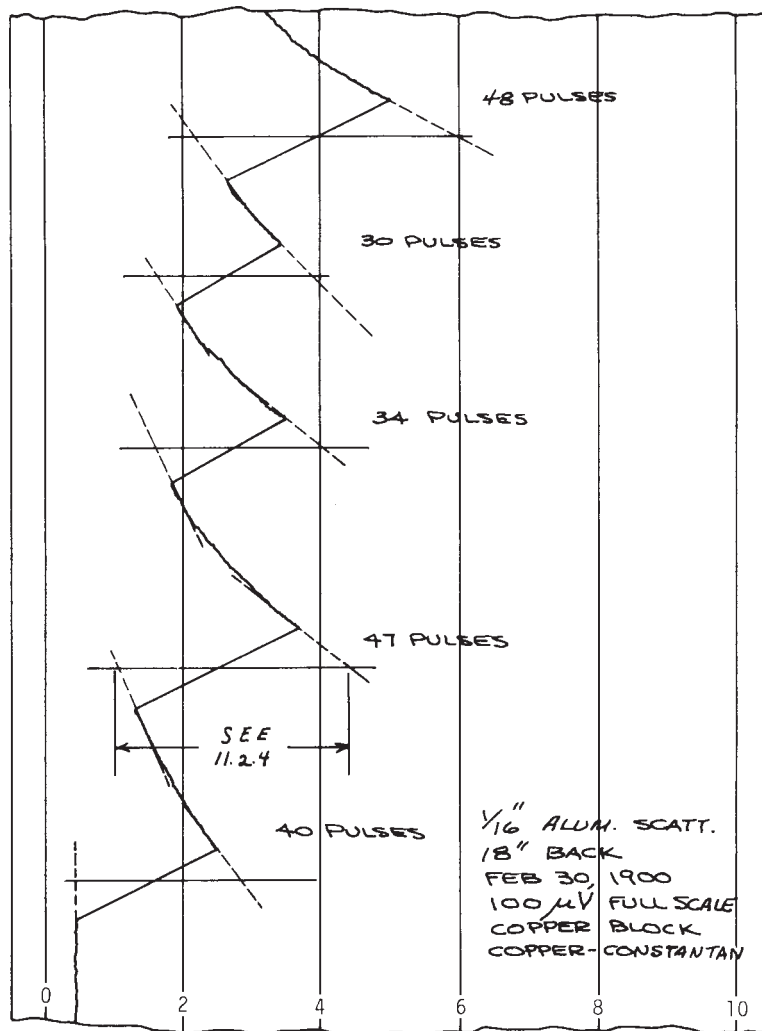

NOTE 1—Rise times have been deliberately lengthened in this figure to enable the construction of the perpendicular and extrapolated lines to be seen more easily.

FIG. 6 Typical Chart Record of Calorimeter Dosimetry Using Multiple-Pulse Method

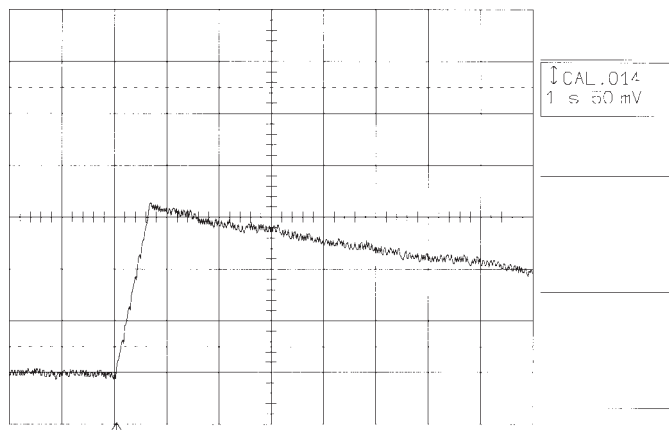

FIG. 7 Multiple Pulse Method Using a Digital Storage Scope and LNA (Five Radiation Pulses)

where:
 Dose B = calculated dose in the different material,

Dose A = measured dose in the calorimeter-block material,
 $dE/dx_{(B)}$ = mass collision stopping power (linear energy loss to ionization) of beam-energy electrons in the different material, and
 $dE/dx_{(A)}$ = mass collision stopping power of beam-energy electrons in the calorimeter-block material.

Absolute values are not required in these tests, only correct voltage-versus-temperature slopes, resulting in an even smaller margin of error.

13.1.2 Assume that handbook values used for the specific heat of calorimeter-block materials are good only to $\pm 5\%$.

13.1.3 Assume that the error in the calibration of the voltmeter-recorder system is $\pm 2\%$.

13.1.4 Assume that noise in the signal, coupled with inaccuracies involved in the extrapolation and measuring procedures, results in errors no greater than $\pm 5\%$ in the determination of the fraction of full-scale deflection of the transient signal on the strip-chart recorder.

13.1.5 Based on these assumptions, the expected error in the dose determination, calculated as the root-mean-square of all error sources, is $\pm 7.6\%$. Maximum error based on the sum of the sources of error is $\pm 16\%$.

13.1.6 An error of up to $\pm 5\%$ in the dE/dx ratio will cause an additional error to be introduced when the dose measured in one material is translated to that deposited in another.

NOTE 11—Energy loss values for some common materials are given in Table 1.

12. Report

12.1 The report shall include, as a minimum, the information required by the report form (see Fig. 8).

13. Precision and Bias

13.1 The following analysis yields an estimate of the expected bias of this test method.

13.1.1 Thermocouple materials are available from the manufacturer with guaranteed limits of error better than 2%.

Operator: _____
 Facility: _____ Date: _____
 Linac Information:
 Beam Energy: _____ MeV Pulse Width: _____ μ sec
 Nominal Beam Current: _____ mA
 Calorimeter Information:
 Calorimeter-Block Material: _____ c_p : _____ J/kg-K
 Thermocouple Material: _____ Sensitivity: _____ μ V/K
 Thermistor or Thermocouple Wire Size: _____
 Thermistor Nominal Resistance: _____ Ω
 Thermistor Temperature Coefficient: _____ K^{-1}
 Wheatstone Bridge Fixed Resistors, R_A : _____ Ω
 Wheatstone Bridge Voltage, E : _____ V
 Insulating Material: _____
 Calorimeter Package Description: _____

Test Geometry: Draw a simple sketch showing relative positions of any collimator, shield, scatter plate, or other possible perturbing structure. Report construction materials and thickness.

Dosimetry Data

Pulse (Pulse Set)	Identification No.	Recorder Deflection (% of Full Scale)	Microvoltmeter Reading (μ V)	No. of Pulses	Calculated Dose/Pulse
1	_____	_____	_____	_____	_____
2	_____	_____	_____	_____	_____
3	_____	_____	_____	_____	_____
4	_____	_____	_____	_____	_____
5	_____	_____	_____	_____	_____

Average Dose/Pulse _____ rad ()

Calculated Dose in Other Materials:

Material A: _____ $dE/dx_{(A)}$: _____
 Material B: _____ $dE/dx_{(B)}$: _____
 Material C: _____ $dE/dx_{(C)}$: _____
 $Dose A = dE/dx_{(A)} / dE/dx_{(CAL)} \cdot Dose(Cal) = \dots = rad ()$
 $Dose B = dE/dx_{(B)} / dE/dx_{(CAL)} \cdot Dose(Cal) = \dots = rad ()$
 $Dose C = dE/dx_{(C)} / dE/dx_{(CAL)} \cdot Dose(Cal) = \dots = rad ()$

FIG. 8 Dosimetry Data Sheet

14. Keywords

14.1 calorimetric measurements; dose measurement; ionizing dose; linac; linear accelerator; radiation effects

APPENDICES

(Nonmandatory Information)

X1. CONSTRUCTION AND USE OF CALORIMETER DOSIMETERS

X1.1 *Use of Thin Calorimeters*—Various types of dosimeters may be used in radiation-effects testing, but one of the most convenient in many ways is a thin calorimeter. Such a calorimeter is called “thin” because its dimensions are small compared to the range of the ionizing radiation depositing the dose which it monitors. The operation of a thin calorimeter depends only on physical constants of materials. Therefore, its performance can be checked with non-radiation measurements, and it is not necessary to calibrate such a dosimeter in a calibrated radiation field. This type of dosimeter can be small, is easy to construct, and requires only simple laboratory instruments (a LNA and data recorder) for its use. When in use, it can be monitored from a remote data-taking station. Entry into the radiation cell is required only when the calorimeter is to be repositioned—not after every pulse, as is the case with passive dosimeters.

X1.2 *Calorimeter Materials*—In the testing of semiconductor components, the material of primary interest is silicon. A calorimeter can be constructed of silicon to yield silicon dose directly; however, it is more difficult to construct a calorimeter of silicon than of many other materials. Because the specific heat of silicon is relatively large, the voltage signal obtained from a silicon calorimeter is smaller for a given radiation pulse than for calorimeters made of other, more easily worked materials. For these reasons, it is sometimes found more desirable to use another material for the calorimeter and then to convert the measured dose to rad(Si).

X1.3 *Calorimeter Construction*—In the construction of a calorimeter, a few important precautions must be observed.

X1.3.1 *Thermocouple Connection*—The first precaution concerns the bonding of the thermocouple to the calorimeter block. For malleable block materials, the best technique is to swage the thermocouple leads to the block. Small holes are drilled in the calorimeter block, and the thermocouple wires are inserted and then crimped in place. With this type of connection, no foreign material is introduced. For many materials, including silicon and germanium, this is not a feasible technique since the material is brittle. The next best method for attachment is thermal epoxy. Care must be exercised when using this type of attachment. The amount of epoxy used must be kept to a minimum. For a calorimeter block of usual size (2.5 to 3.0 mm square and about 0.5 mm thick has been found to be a convenient size), the epoxy contact should be no larger than 0.5 mm in diameter.

X1.3.1.1 *Effect of Excessive Bonding Material*—It must be emphasized that excess bonding material will distort the signal obtained on the recorder chart. The calorimeter block must make up 97 % or more of the active calorimeter mass. Because of differing specific heats and different doses deposited in materials at the point of attachment of the thermocouple, the initial temperature rise may not reflect the temperature rise of the calorimeter block; but if the block makes up the bulk of the material, the temperature will quickly equilibrate to that of the calorimeter block. When such effects occur, it is quite obvious on the data trace. Such initial signals are to be ignored when making extrapolations of the cooling curves (see 11.1.2.2).

X1.3.2 *Thermistor Bonding*—It is essential that the thermistor and the material used to bond it to the calorimeter block are small in mass compared to the block, so that there is only a small perturbation of the calorimeter block equilibrium temperature caused by differential heating of the thermistor and block by the radiation pulse. A small (~0.04-cm diameter) bead thermistor may be bonded to the block with a small amount of varnish or epoxy, or a commercial unit may be used. One commercial unit consists of a small “flake” thermistor bonded to a substrate chip. Several substrate materials, one of which is silicon, are available.

X1.3.3 *Thermal Isolation*—The second precaution to observe when making a thin calorimeter is to ensure good thermal isolation of the calorimeter block from its surroundings.

X1.3.3.1 *Thermocouple Leads*—The thermocouple leads themselves form heat leaks from the calorimeter block. This leakage may be minimized by using small-diameter thermocouple leads to create a high thermal impedance. Experience has shown that 25.4- μm (1-mil) diameter wire serves very well for this purpose, but it is difficult to work with and causes additional problems with mechanical integrity. An adequately high thermal impedance is provided by 127- μm (5-mil) diameter wire, and it is strong enough to provide some mechanical integrity. The length of small thermocouple wire need be only 10 to 20 mm to provide a high thermal impedance. It should then be joined to larger gage thermocouple wire to provide mechanical strength to the leads. AWG-28 (0.321-mm) to 20 (0.812-mm) wire provides good strength and flexibility for most calorimeter applications. The fine wire can be joined to the larger one either by welding or by soldering. **Warning**—Strain relief must be provided to prevent breakage of the smaller wires. The larger diameter thermocouple wire should be long enough so that the transition to copper wire is well out

of the radiation field. This transition can be made by welding or soldering, but it is more convenient to use a connector at this junction.

X1.3.3.2 Thermistor Leads—The same precautions stated in X1.3.3.1 must be observed with small size leads from thermistors. Small bead or flake thermistors are only supplied with 1-mil leads, so the main precaution is to supply strain relief so that these fragile wires are not broken in fabrication or handling of the calorimeter. Conversion to larger size copper conductors should take place within 5 to 20 mm of the calorimeter block. Soft soldering is the preferred method of attachment.

X1.3.3.3 Insulation—The other consideration for good thermal isolation is insulation surrounding the calorimeter block. Poor insulation results in the thermocouple being affected severely by local air drafts. The presence of drafts is indicated on the recorder as noise and can easily mask the signal response to the radiation pulse. Poor insulation also leads to too short of a thermal time constant so that cooldown following a radiation pulse is quite rapid. The slope of the cooldown curve is then so steep that large errors can be made in extrapolating the cooldown curve back to the initiation of the transient. If the calorimeter block is mounted in a TO-5 can or in some other standard device package, it will be protected from drafts; but if the insulation is poor, response to a radiation pulse may be warped. The package may easily be heated by the pulse to a temperature higher than that of the calorimeter block, and the recorder trace following the radiation pulse may actually rise due to added heating from the package, rather than showing an exponential cooling rate. Closed cell plastic foams are excellent insulation, although it tends to deteriorate with repeated radiation exposure. It is sufficient to mount the calorimeter block between two pieces of plastic foam or some other insulating material, which are then fastened together. Depending on the packaging of the calorimeter, this fastening can be accomplished by gluing or wiring or simply by compression-fit inside a package.

X1.3.4 Configuration—The physical configuration of the calorimeter can assume many forms. Some of these are shown in Fig. X1.1. This figure shows only thermocouple calorimeters, but similar packaging can be used for thermistor calorimeters. It is often desirable to have the calorimeter packaged in the same type of package as the units being radiation-tested for which the dose measurement are being made.

X1.3.5 Thermocouple Wire—Standard thermocouple wire is available from a number of manufacturers. Any common thermocouple materials can be used—Type E (Chromel-constantan) thermocouples have the highest emf output of any standard thermocouples; however, Type K (Chromel-Alumel) and Type T (copper-constantan) are easily obtained and have an adequate temperature coefficient at room temperature for

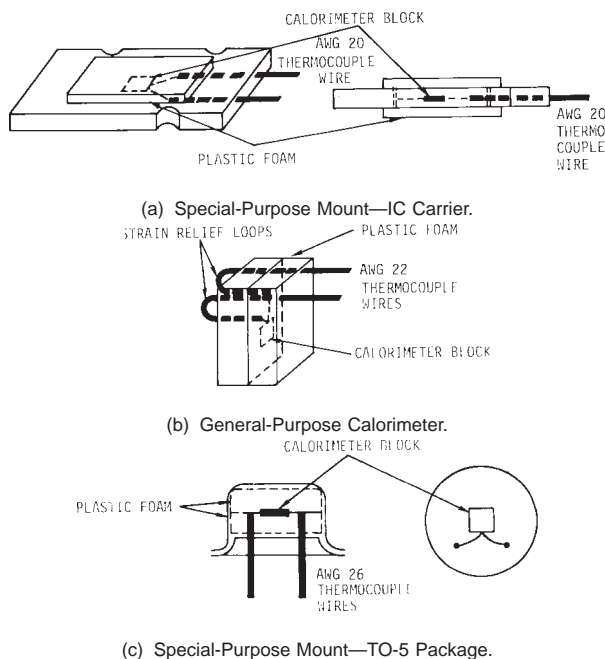

FIG. X1.1 Various Possible Configurations for Calorimeters

calorimeter use (approximately $41 \mu\text{V/K}$ for both). See Standard E 230. For mounting calorimeters in TO-5 cans, the normal leads are removed and replaced with AWG-26 (0.405-mm) thermocouple wire.

X1.4 Use with Other Than Linear Accelerator—The calorimeter described here may be used as a dosimeter with any type of ionizing radiation source. However, many precautions must be taken when it is used at facilities other than linear accelerators. **Warning**—These depend primarily on the energy spectrum of the source and on interfaces between the materials being irradiated. Use in high-energy electron beams between 10 and 50 MeV makes many of these precautions unnecessary and simplifies the use of this dosimeter. Extension of this test method to other types of radiation beam requires careful dose deposition analysis.

X1.5 Thermistor Calorimeter—As long as the thermal equilibration time of the calorimeter is short compared to its thermal time constant, the extrapolation methods of the data reduction compensate for any thermal lag resulting from the thermal impedance of the bonding material. However, this thermal impedance may be altered by continued irradiations, and the useful life of the thermistor calorimeter may be shortened by this effect. Because this thermal impedance could cause errors, it is recommended that such a calorimeter be cross calibrated against a thermocouple calorimeter periodically.

X2. DERIVATION OF THERMISTOR-BRIDGE EQUATION

X2.1 *Bridge Circuit*—Although various bridge configurations could be used, the formulation presented in 11.1.6 is based on the use of the Wheatstone Bridge circuit shown in Fig. 1.

X2.1.1 Applicable Equations:

$$V_T = [(R_T) / (R_A + R_T)] E \quad (X2.1)$$

$$V_B = V_T + [(R_B) / (R_A + R_B)] E \quad (X2.2)$$

$$V_B = [(R_B) / (R_A + R_B) - (R_T) / (R_A + R_T)] E \quad (X2.3)$$

X2.2 *Analysis*—At balance $R_B = R_T$, so $V_B = 0$. After a radiation pulse with the bridge near balance,

$$\Delta V_B = [(R_A) / (R_A + R_B) - (R_T - \Delta) / (R_A + R_T - \Delta)] E \quad (X2.4)$$

where Δ is the change in the thermistor resistance due to the temperature change of the calorimeter block caused by the radiation pulse. As the bridge was near balance prior to the pulse $R_B \approx R_T$. Making this substitution:

$$\Delta V_B = [(R_A) / (R_A + R_B) - (R_B - \Delta) / (R_A + R_B - \Delta)] E \quad (X2.5)$$

$$\Delta V_B \approx [(R_A \Delta) / (R_A + R_B)^2] E$$

X2.2.1 But

$$\Delta = \alpha R_T \Delta T \approx \alpha R_B \Delta T \quad (X2.6)$$

where:

α = thermistor temperature of resistance, K^{-1} ,

R_T = thermistor resistance prior to pulse, Ω , and

ΔT = temperature rise in the calorimeter caused by the pulse, K .

X2.2.2 However,

$$\Delta T = (D) / (K C_p) \quad (X2.7)$$

where:

D = dose delivered in the pulse, rad (calorimeter material)

C_p = specific heat of the calorimeter block material, $J/kg \cdot K$, and

K = numerical conversion constant, 10^2 rad·kg/J.

X2.2.3 Substituting,

$$\Delta V_B = [(R_A R_B) / (R_A + R_B)^2 (\alpha E / K C_p)] D \quad (X2.8)$$

X2.2.4 Transposing,

$$D = [(R_A + R_B)^2 / (R_A R_B) (K C / \alpha E)] \Delta V_B. \quad (X2.9)$$

ASTM International takes no position respecting the validity of any patent rights asserted in connection with any item mentioned in this standard. Users of this standard are expressly advised that determination of the validity of any such patent rights, and the risk of infringement of such rights, are entirely their own responsibility.

This standard is subject to revision at any time by the responsible technical committee and must be reviewed every five years and if not revised, either reapproved or withdrawn. Your comments are invited either for revision of this standard or for additional standards and should be addressed to ASTM International Headquarters. Your comments will receive careful consideration at a meeting of the responsible technical committee, which you may attend. If you feel that your comments have not received a fair hearing you should make your views known to the ASTM Committee on Standards, at the address shown below.

This standard is copyrighted by ASTM International, 100 Barr Harbor Drive, PO Box C700, West Conshohocken, PA 19428-2959, United States. Individual reprints (single or multiple copies) of this standard may be obtained by contacting ASTM at the above address or at 610-832-9585 (phone), 610-832-9555 (fax), or service@astm.org (e-mail); or through the ASTM website (www.astm.org).