



Designation: F 744M – 97

METRIC

Standard Test Method for Measuring Dose Rate Threshold for Upset of Digital Integrated Circuits [Metric]¹

This standard is issued under the fixed designation F 744M; the number immediately following the designation indicates the year of original adoption or, in the case of revision, the year of last revision. A number in parentheses indicates the year of last reappraisal. A superscript epsilon (ϵ) indicates an editorial change since the last revision or reappraisal.

1. Scope

1.1 This test method covers the measurement of the threshold level of radiation dose rate that causes upset in digital integrated circuits under static operating conditions. The radiation source is either a flash X-ray machine (FXR) or an electron linear accelerator (LINAC).

1.2 The precision of the measurement depends on the homogeneity of the radiation field and on the precision of the radiation dosimetry and the recording instrumentation.

1.3 The test may be destructive either for further tests or for purposes other than this test if the integrated circuit being tested absorbs a total radiation dose exceeding some predetermined level. Because this level depends both on the kind of integrated circuit and on the application, a specific value must be agreed upon by the parties to the test (6.8).

1.4 Setup, calibration, and test circuit evaluation procedures are included in this test method.

1.5 Procedures for lot qualification and sampling are not included in this test method.

1.6 Because of the variability of the response of different device types, the initial dose rate for any specific test is not given in this test method but must be agreed upon by the parties to the test.

1.7 *This standard does not purport to address all of the safety concerns, if any, associated with its use. It is the responsibility of the user of this standard to establish appropriate safety and health practices and determine the applicability of regulatory limitations prior to use.*

2. Referenced Documents

2.1 ASTM Standards:

E 665 Practice for Determining Absorbed Dose Versus Depth in Materials Exposed to the X-Ray Output of Flash X-Ray Machines²

¹ This test method is under the jurisdiction of ASTM Committee F-1 on Electronics and is the direct responsibility of Subcommittee F01.11 on Quality and Hardness Assurance.

Current edition approved Feb. 10, 1997. Published April 1997. Originally published as F 744 – 81. Last previous edition F 744 – 92.

² *Annual Book of ASTM Standards*, Vol 12.02.

E 666 Practice for Calculating Absorbed Dose from Gamma or X Radiation²

E 668 Practice for Application of Thermoluminescence-Dosimetry (TLD) Systems for Determining Absorbed Dose in Radiation-Hardness Testing of Electronic Devices²

F 526 Test Method for Measuring Dose for Use in Linear Accelerator Pulsed Radiation Effects Tests³

3. Terminology

3.1 Definitions of Terms Specific to This Standard:

3.1.1 *determined integrated circuit*—integrated circuit whose output is a unique function of the inputs; the output changes if and only if the input changes (for example, AND- and OR-gates).

3.1.2 *dose rate*—energy absorbed per unit time and per unit mass by a given material from the radiation to which it is exposed.

3.1.3 *dose rate threshold for upset*—minimum dose rate that causes either: (1) the instantaneous output voltage of an operating digital integrated circuit to be greater than the specified maximum LOW value (for a LOW output level) or less than the specified minimum HIGH value (for a HIGH output level), or (2) a change of state of any stored data.

3.1.4 *nondetermined integrated circuit*—integrated circuit whose output or internal operating conditions are not unique functions of the inputs (for example, flip-flops, shift registers, and RAMs).

4. Summary of Test Method

4.1 The test device and suitable dosimeters are irradiated by either an FXR or a LINAC. The test device is operating but under static conditions. The output(s) of the test device and of the dosimeters are recorded.

4.2 The dose rate is varied to determine the rate which results in upset of the test device.

4.3 For the purposes of this test method, upset is considered to be either of the following:

4.3.1 An output voltage transient exceeding a predetermined value, or

³ *Annual Book of ASTM Standards*, Vol 10.04.

4.3.2 For devices having output logic levels which are not unique functions of the input logic levels, such as flip-flops, a change in the logic state of an output.

4.3.3 For nondetermined integrated circuits, a change of state of an internal storage element or node.

4.4 A number of factors are not defined in this test method, and must be agreed upon beforehand by the parties to the test:

4.4.1 Total dose limit (see 1.3),

4.4.2 Transient values defining an upset (see 4.3.1),

4.4.3 Temperature at which the test is to be performed (see 6.7),

4.4.4 Details of the test circuit, including output loading, power supply levels, and other operating conditions (see 7.4, 10.3, and 10.4),

4.4.5 Choice of radiation pulse source (see 7.7),

4.4.6 Radiation pulse width (see 7.7.2),

4.4.7 Sampling (see 8.1),

4.4.8 Need for total dose measurement (see 6.8, 7.6, and 10.1),

4.4.9 Desired precision of the upset threshold (see 10.8), and

4.4.10 Initial dose rate (see 1.6 and 10.5).

5. Significance and Use

5.1 Digital integrated circuits are specified to operate with their inputs and outputs in either a logical 1 or a logical 0 state. The occurrence of signals having voltage levels not meeting the specifications of either of these levels (an upset condition) may cause the generation and propagation of erroneous data in a digital system.

5.2 Knowledge of the radiation dose rate that causes upset in digital integrated circuits is essential for the design, production, and maintenance of electronic systems that are required to operate in the presence of pulsed radiation environments.

6. Interferences

6.1 *Air Ionization*—A spurious component of the signal measured during a test can result from conduction through air ionized by the radiation pulse. The source of such spurious contributions can be checked by measuring the signal while irradiating the test fixture in the absence of a test device. Air ionization contributions to the observed signal are generally proportional to the applied field, while those due to secondary emission effects (6.2) are not. The effects of air ionization external to the device may be minimized by coating exposed leads with a thick layer of paraffin, silicone rubber, or nonconductive enamel or by making the measurement in a vacuum.

6.2 *Secondary Emission*⁴—Another spurious component of the measured signal can result from charge emission from, or charge injection into, the test device and test circuit. This may be minimized by shielding the surrounding circuitry and irradiating only the minimum area necessary to ensure irradiation of the test device. Reasonable estimates of the magnitude to be expected of current resulting from secondary-emission

effects can be made based on the area of metallic target materials irradiated (see Note 1). Values generally range between 10^{-11} and 10^{-10} A·s/cm²·Gy, but the use of a scatter plate with an intense beam may increase this current (7.7.2).

NOTE 1—For dose rates in excess of 10^8 Gy(Si)/s, the photocurrents developed by the package may dominate the device photocurrent. Care should be taken in the interpretation of the measured photoresponse for these high dose rates.

6.3 *Orientation*—The effective dose to a semiconductor junction can be altered by changing the orientation of the test device with respect to the irradiating beam. Most integrated circuits may be considered “thin samples” (in terms of the range of the radiation). However, some devices may have cooling studs or thick-walled cases that can act to scatter the incident beam, thereby modifying the dose received by the semiconductor chip. Care must be taken in the positioning of such devices.

6.4 *Dose Enhancement*—High atomic number materials near the active regions of the integrated circuit (package, metallization, die attach materials, etc.) can cause an enhanced dose to be delivered to the sensitive regions of the device when it is irradiated with bremsstrahlung. Therefore, when an FXR is used as the radiation source, calculations should be performed to determine the possibility and extent of this effect.

6.5 *Electrical Noise*—Since radiation test facilities are inherent sources of r-f electrical noise, good noise-minimizing techniques such as single-point ground, filtered d-c supply lines, etc., must be used in these measurements.

6.6 *Temperature*—Device characteristics are dependent on junction temperature; hence, the temperature of the test should be controlled. Unless the parties to the test agree otherwise, measurements shall be made at room temperature ($23 \pm 5^\circ\text{C}$).

6.7 *Beam Homogeneity and Pulse-to-Pulse Repeatability*—The intensity of a beam from an FXR or a LINAC is likely to vary across its cross section. Since the pulse-shape monitor is placed at a different location than the device under test, the measured dose rate may be different from the dose rate to which the device was exposed. The spatial distribution and intensity of the beam may also vary from pulse to pulse. The beam homogeneity and pulse-to-pulse repeatability associated with a particular radiation source should be established by a thorough characterization of its beam prior to performing a measurement.

6.8 *Total Dose*—Each pulse of the radiation source imparts a dose to both the device under test and the device used for dosimetry. The total dose deposited in a semiconductor device can change its operating characteristics. As a result, the response that is measured after several pulses may be different from that characteristic of an unirradiated device. Care should be exercised to ensure that the total dose delivered to the test device is less than the agreed-upon maximum value. Care must also be taken to ensure that the characteristics of the dosimeter have not changed due to the accumulated dose.

7. Apparatus

7.1 *Regulated d-c Power Supplies*, with floating outputs to produce the voltages required to bias the integrated circuit under test.

⁴ Sawyer, J. A., and van Lint, V. A. J., “Calculations of High-Energy Secondary Electron Emission,” *Journal of Applied Physics*, Vol 35, No. 6, June 1964, pp. 1706–1711.

7.2 *Recording Devices*—A single dual-beam, or two single-beam oscilloscopes, equipped with cameras; or transient digitizers with appropriate displays. The bandwidth capabilities of the recording devices shall be such that the radiation responses of the integrated circuit and the pulse-shape monitor (7.6) are accurately displayed and recorded.

7.3 *Cabling*, to complete adequately the connection of the test circuit in the exposure area with the power supply and oscilloscopes in the data area. Shielded twisted pair or coaxial cables may be used to connect the power supplies to the bias points of the test circuit; however, coaxial cables properly terminated at the oscilloscope input are required for the signal leads.

7.4 *Test Circuit* (see Fig. 1)—Although the details of test circuits for this test must vary depending on the kind of integrated circuit to be tested and on the specific parameters of the circuit which are to be measured, Fig. 1 provides the information necessary for the design of a test circuit for most purposes. The capacitor, C , provides an instantaneous source of current as may be required by the integrated circuit during the radiation pulse. Its value must be large enough that the decrease in the supply voltage during a pulse is less than 10%. The capacitor, C , should be paralleled by a small (approximately 0.01 μF) low-inductance capacitor to ensure that possible inductive effects of the large capacitor are offset. Both capacitors must be located as close to the integrated circuit socket as possible, consistent with the space needed for connection of the current transformer and for any shielding that may be necessary. The switch, S , provides means to place the output of the integrated circuit (here a NAND gate) in either a logic LOW or a logic HIGH state. The arrangement of the grounding connections provides that only one ground exists, at the point of measurement. This eliminates the possibility of ground loops and reduces the common-mode signals present at the terminals of the measurement instruments. The resistor, R_0 ,

is the termination for the coaxial cable and has a value within 2% of the characteristic cable impedance. All unused inputs to the test device are connected as agreed upon between the parties to the test. The output of the test device may be loaded, as agreed upon between the parties to the test. To prevent loading of the output of the test device by the coaxial cable, one may use a line driver that has a high input impedance and adequate bandwidth and voltage swing to reproduce accurately at the output end of the coaxial cable, the waveforms appearing at the line-driver input.

7.5 *Radiation Pulse-Shape Monitor*—Use one of the following to develop a signal proportional to the dose rate delivered to the test device:

7.5.1 *Fast Signal Diode*, in the circuit configuration of Fig. 2. The resistors, R_1 , serve as high-frequency isolation and must be at least 20 Ω . The capacitor, C , supplies the charge during the current transient; its value must be large enough that the decrease in voltage during a current pulse is less than 10%. The capacitor, C , should be paralleled by a small (approximately 0.01 μF) low-inductance capacitor to ensure that possible inductive effects of the large capacitor are offset. The resistor, R_0 , is to provide the proper termination (within $\pm 2\%$) for the coaxial cable used for the signal lead. This is the preferred apparatus for this purpose.

7.5.2 *P-I-N Diode*, in the circuit configuration of Fig. 2 as described in 7.5.1. Care should be taken to avoid saturation effects.

7.5.3 *Current Transformer*, mounted on a collimator at the output window of the linear accelerator so that the primary electron beam passes through the opening of the transformer after passing through the collimator. The current transformer must have a bandwidth sufficient to ensure that the current signal is accurately displayed. Rise time must be less than 10% of the pulse width of the radiation pulse being used. The low frequency cutoff of some commercial current transformers is

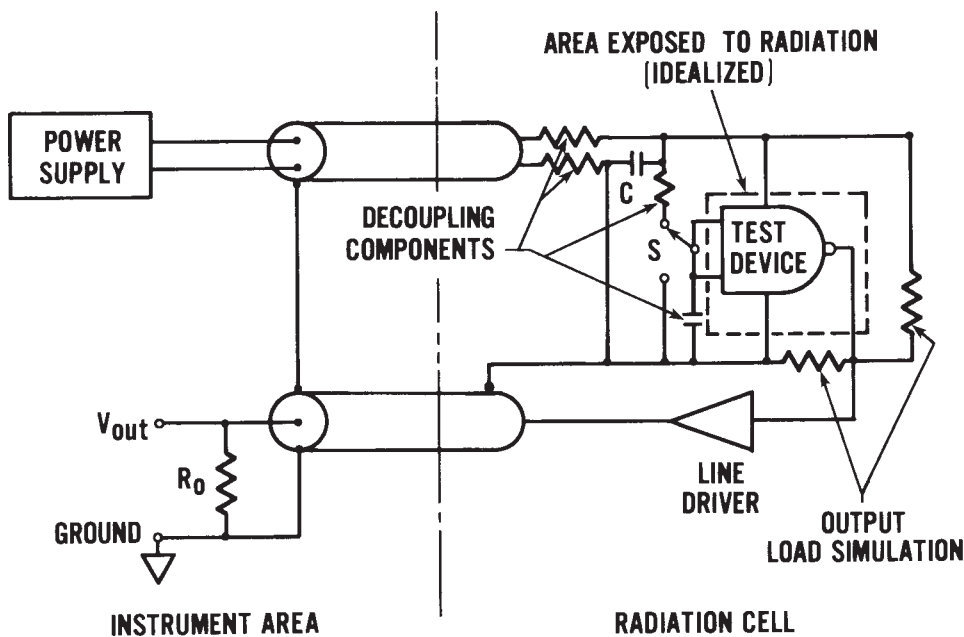

FIG. 1 Test Circuit Example for a NAND Gate

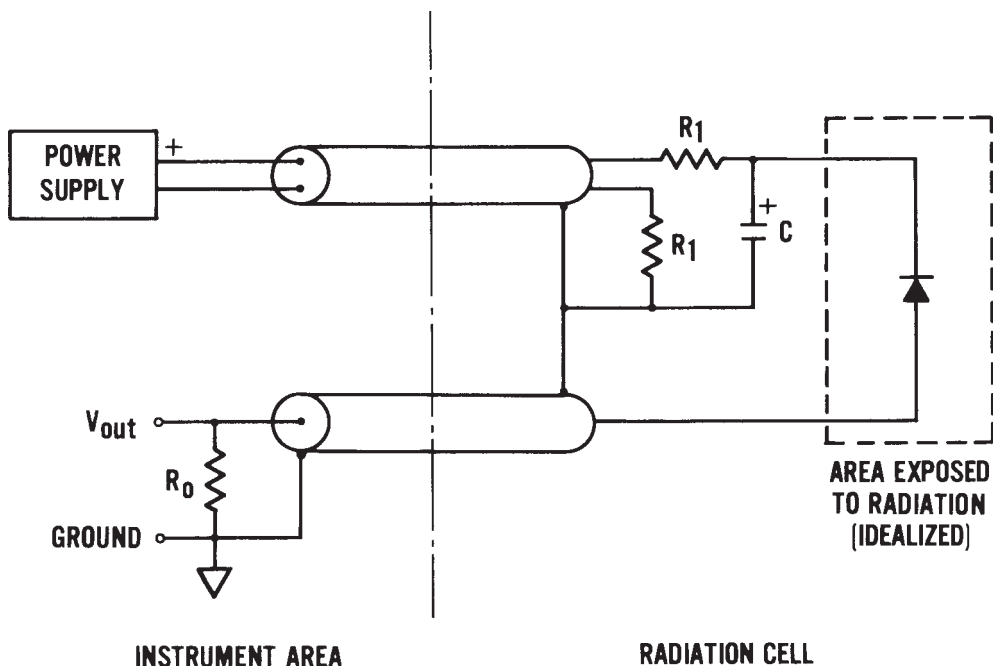

FIG. 2 Irradiation Pulse-Shape Monitor Circuit for Diodes

such that significant droop may occur for pulse widths greater than $1 \mu\text{s}$. Do not use a transformer for which this droop is greater than 5 % for the radiation pulse width used. When monitoring large currents, care must be taken that the current-time saturation rating of the current transformer is not exceeded. It may be required that the signal cable monitoring the current transformer be matched to the characteristic impedance of the transformer, in which case R_0 would have this impedance (within $\pm 2\%$), as specified by the manufacturer of the current transformer.

NOTE 2—Because the radiation beam from an FXR is a photon beam rather than an electron beam, a current transformer cannot be used as a pulse-shape monitor with an FXR.

7.5.4 *Secondary-Emission Monitor*, consisting of a thin foil, biased negatively with respect to ground, mounted in an evacuated chamber with thin windows through which the primary radiation beam passes after passing through a collimator. A resistor, in series with the foil and bias supply, is used to sense the current.

7.6 *Dosimeter*—Use one of the following types of dosimeter to calibrate the output of the pulse-shape monitor in terms of dose rate to determine the ionizing dose to which the test device is exposed (see 4.4.8).

7.6.1 *Commercial Thermoluminescent Dosimeter (TLD)* and readout system.

7.6.2 *Thin Calorimeter* and associated strip-chart recorder and preamplifier as defined in Test Method F 526.

7.7 *Radiation Pulse Source*—One of the following machines:

7.7.1 *Flash X-Ray Machine (FXR)*, used in the photon mode and capable of delivering a peak dose rate sufficient for the test.

NOTE 3—The use of an FXR at peak tube voltages below 2 MeV is not recommended. If such use is required, care must be taken to account for

dosimetry problems arising from spectrum dependent dose-enhancement effects.

7.7.2 *Electron Linear Accelerator (LINAC)*, capable of producing pulses of electrons with energies greater than 10 MeV, in pulses with a width within the range agreed upon between the parties to the test. The primary electron beam is used as the ionizing source. A thin scatter plate of a material with low atomic number, such as aluminum, 0.15 to 0.65 cm thick, may be placed at the exit window of the linear accelerator to spread the beam and somewhat homogenize it so that positioning of the test device is not as critical as it would be if the beam were unscattered.

NOTE 4—**Caution:** There is approximately 5 MeV/cm energy attenuation of the beam passing through aluminum.

7.8 *Resistive Network*, designed to simulate the integrated circuit impedances, for use in evaluating the spurious responses of the test circuit. The network should present impedances to the power supply, input, and output connections of the integrated circuit socket in the test circuit, which approximate the active impedances of the integrated circuit type to be tested.

7.9 *Temperature-Measuring Device*, to measure ambient temperature in the vicinity of the device under test to $\pm 1^\circ\text{C}$.

8. Sampling

8.1 This test method determines the properties of a single specimen. If sampling procedures are used to select devices for test, the procedures shall be agreed upon between the parties to the test.

9. Preparation of Apparatus

9.1 Select an appropriate test circuit and align it with the beam of the radiation source. Position the scatter plate and appropriate shielding, collimation, and pulse-shape monitor.



9.2 Determine the dose-rate factor for calibration of the pulse-shape monitor by the procedure of 9.2.1 if an FXR is to be used, or by either the procedure of 9.2.1 or 9.2.2 if a LINAC is to be used.

9.2.1 *Thermoluminescent Dosimeter (TLD)*—Mount the TLD in the position to be occupied by the test device. Pulse the radiation source and record the pulse-shape monitor signal. Remove the TLD and determine the dose in accordance with the manufacturer's instructions. Graphically integrate the irradiation pulse-shape monitor signal and calculate a dose-rate factor as follows:

$$F = \gamma/\Sigma \quad (1)$$

where:

F = dose-rate factor, Gy(Si)/(V·s),

γ = dose, Gy(Si), and

Σ = integrated pulse-shape monitor signal, V·s.

Repeat the measurement five times and average. Use this value for the dose-rate factor.

NOTE 5—Use Practices E 665, E 666, or E 668 as appropriate to obtain the best precision in the measurement of the dose-rate factor when TLDs are used.

9.2.2 *Thin Calorimeter*—Mount the calorimeter in the position to be occupied by the test device. Provide thermal isolation for the calorimeter foil. Pulse the radiation source, record the pulse-shape monitor signal on film and the temperature rise of the calorimeter on the strip-chart recorder. Calculate the dose delivered from the temperature rise as follows:

$$\gamma = \Delta T c_p \quad (2)$$

where:

γ = dose, Gy (calorimeter material),

ΔT = temperature rise, °C, and

c_p = specific heat at constant pressure of calorimeter material, J/(kg·°C).

Graphically integrate the irradiation pulse-shape monitor signal and calculate a dose-rate factor from Eq 1. Repeat the measurement five times and average. Use this value for the dose-rate factor. Doses in other calorimeter materials can be translated into equivalent silicon doses by using the procedure in Test Method F 526.

NOTE 6—The use of Test Method F 526 is recommended to obtain the best precision in the measurement of the dose-rate factor when a LINAC is used.

9.3 *Test Circuit with Device Removed*—With the resistive network in the test circuit, apply the bias to be used (see 10.3) and pulse the radiation source to deliver a dose rate equal to the initial value (4.4.10) or greater. Record both the irradiation pulse-shape monitor signal and the signal from the test circuit. The measured signal should be less than or equal to one tenth the anticipated transient signal. If it is, proceed with the test (Section 10). If it is not, change the bias and repeat. If the signal changes (indicating air-ionization problems), pot the exposed leads of the test circuit (6.1). If the signal is still large and affected little by the applied bias, restrict still further the exposure area and increase the shielding of the test circuit, or remove the scatter plate, or both, and repeat the measurement. Continue in this manner until a signal of one tenth the

anticipated transient signal or less is obtained. Record the actual values measured and the changes made.

10. Procedure

10.1 Mount the test device in the test circuit. Install a fresh TLD adjacent to the test device, if total dose recording is required (4.4.8).

10.2 Measure and record the ambient temperature in the vicinity of the test device.

10.3 Apply power supply voltage(s) to the test device at level(s) agreed upon between the parties to the test.

NOTE 7—Minimum values of power supply voltage and maximum output loading permissible under the manufacturer's specifications have generally been found to provide worst-case conditions (that is, most sensitive to upset) for this test.

10.4 Establish the initial operating state of the test device.

10.4.1 For determined devices, set the input conditions so that the output(s) to be monitored is(are) in the HIGH state.

10.4.2 For nondetermined devices, store the specified pattern of ones and zeroes in the test device.

10.5 Adjust the radiation source to the initial dose-rate value, and record both the irradiation pulse-shape monitor signal and the signals from the test circuit as required.

10.5.1 When necessary, determine the dose rate by multiplying the dose rate factor (9.2) by the voltage of the radiation pulse-shape monitor (7.5).

10.6 To determine if upset has occurred, examine the recorded signals from the test circuit and, in the case of nondetermined devices, read the stored pattern of ones and zeroes to see if any have been changed.

NOTE 8—If the stored pattern of ones and zeros has changed, it may be desirable to correct it to its original specified pattern. Recycle the power supply if required to correct any microlatchup.

10.7 Adjust the dose rate produced by the radiation source upward or downward, as appropriate.

10.8 Establish the dose rate threshold of the test device to the degree of precision desired by the parties to the test, by repeating 10.6 and 10.7. At the same time attempt to limit, as much as possible, the total dose the test device is exposed to.

NOTE 9—A recommended iteration strategy is to, first, establish the dose rate decade interval in which upset occurs by increasing the dose rate of successive pulses by a factor of ten for each pulse until upset is observed, and then halve this dose rate successively until the requirements of 10.8 are met.

10.9 For determined devices, set the input conditions so that the output(s) to be monitored is (are) in the *low* state, and repeat 10.5-10.8.

10.10 Record the lowest dose rate value that resulted in upset and, for nondetermined devices, whether the upset was caused by an excessive output voltage transient or by a change in the stored data pattern.

10.11 Record the highest dose rate value that did not result in upset.

10.12 Record the total dose the test device was exposed to (7.7 and 10.1).

11. Report

11.1 Report the following for each device tested:



- 11.1.1 Device identification, including type number, date code, and manufacturer,
- 11.1.2 Date of test and name of test operator,
- 11.1.3 Identification of radiation pulse source, pulse width, and spectrum incident upon the device under test (DUT),
- 11.1.4 Description of scatter plate, if used,
- 11.1.5 Description of test circuit, showing the output pins which were monitored,
- 11.1.6 Description of radiation pulse-shape monitor,
- 11.1.7 Dosimetry technique,
- 11.1.8 Test-circuit responses with resistive network in place (9.3),
- 11.1.9 Input bias and output loading conditions,
- 11.1.10 The pattern of stored ones and zeroes, for nonde-termined devices,
- 11.1.11 Records of upset transients for both HIGH and LOW states,
- 11.1.12 Minimum dose rate resulting in upset,
- 11.1.13 Maximum dose rate resulting in no upset,
- 11.1.14 Record of the irradiation pulse-shape monitor at upset,
- 11.1.15 Total dose, if required, and
- 11.1.16 Ambient temperature.

12. Precision and Bias

12.1 *Precision*—Three device types were used in an inter-laboratory experiment: SN7400's Au-doped TTL NAND gates; SN74S00's Schottky (non-gold-doped) TTL NAND gates; and SN7474's dual D-type positive-edge-triggered flip-flops. Each device type contains two of the devices on the chip. The input of one of the devices was biased at + 5 V; the input of the other was biased at 0 V during the tests. Loads were placed on the

device outputs to simulate other circuit elements. The criterium for upset of the gate or flip flop was a 1-V transient excursion observed on the output line. Five devices of each type were used for the tests. The range of dose rates used in this experiment was 9×10^5 to 6.6×10^7 Gy/s.

12.2 Four laboratories were involved in the experiment. A common text fixture for the devices under test was used by all laboratories. Peripheral instrumentation such as power supplies, oscilloscopes etc was supplied by the individual laboratories. In addition, dosimetry was performed at each laboratory using that laboratory's instruments and dosimetry techniques. Each part was tested using a 1- μ s and a 50-ns pulse. Upset of SN7400's when the input line was at 0 V could not be achieved by any laboratory due to limitations of the linac beam intensities.

12.3 The standard deviation of the measurements observed in the interlaboratory experiment ranged from 11.8 to 30.6 % (1 σ) for a particular device type and input bias voltage. Comparing results between laboratories for a particular part, the standard deviation ranged from 1.9 to 42.6 % (1 σ). Further analysis of the results indicated that the largest variations were due to differences in the interlaboratory results.

12.4 *Bias*—Comparing results within individual laboratories for a particular part type and bias voltage, the standard deviation ranged from 3.7 to 23.8 %. No systematic bias due to dosimetry, pulse characteristics, or other potential variables was found in any laboratory's results.

13. Keywords

13.1 DIC; digital integrated circuits; dose rate; ionizing radiation; radiation dose rate; threshold for upset; upset

ASTM International takes no position respecting the validity of any patent rights asserted in connection with any item mentioned in this standard. Users of this standard are expressly advised that determination of the validity of any such patent rights, and the risk of infringement of such rights, are entirely their own responsibility.

This standard is subject to revision at any time by the responsible technical committee and must be reviewed every five years and if not revised, either reapproved or withdrawn. Your comments are invited either for revision of this standard or for additional standards and should be addressed to ASTM International Headquarters. Your comments will receive careful consideration at a meeting of the responsible technical committee, which you may attend. If you feel that your comments have not received a fair hearing you should make your views known to the ASTM Committee on Standards, at the address shown below.

This standard is copyrighted by ASTM International, 100 Barr Harbor Drive, PO Box C700, West Conshohocken, PA 19428-2959, United States. Individual reprints (single or multiple copies) of this standard may be obtained by contacting ASTM at the above address or at 610-832-9585 (phone), 610-832-9555 (fax), or service@astm.org (e-mail); or through the ASTM website (www.astm.org).