



Standard Practice for Measuring Dose Rate Response of Linear Integrated Circuits [Metric]¹

This standard is issued under the fixed designation F 773M; the number immediately following the designation indicates the year of original adoption or, in the case of revision, the year of last revision. A number in parentheses indicates the year of last reapproval. A superscript epsilon (ϵ) indicates an editorial change since the last revision or reapproval.

1. Scope

1.1 This practice covers the measurement of the response of linear integrated circuits, under given operating conditions, to pulsed ionizing radiation. The response may be either transient or more lasting, such as latchup. The radiation source is either a flash X-ray machine (FXR) or an electron linear accelerator (LINAC).

1.2 The precision of the measurement depends on the homogeneity of the radiation field and on the precision of the radiation dosimetry and the recording instrumentation.

1.3 The test may be considered to be destructive either for further tests or for other purposes if the total radiation dose exceeds some predetermined level or if the part should latch up. Because this level depends both on the kind of integrated circuit and on the application, a specific value must be agreed upon by the parties to the test. (See 6.10.)

1.4 Setup, calibration, and test circuit evaluation procedures are included in this practice.

1.5 Procedures for lot qualification and sampling are not included in this practice.

1.6 Because response varies with different device types, the dose rate range for any specific test is not given in this practice but must be agreed upon by the parties to the test.

1.7 *This standard does not purport to address all of the safety concerns, if any, associated with its use. It is the responsibility of the user of this standard to establish appropriate safety and health practices and determine the applicability of regulatory limitations prior to use.*

2. Referenced Documents

2.1 ASTM Standards:

E 668 Practice for Application of Thermoluminescence-Dosimetry (TLD) Systems for Determining Absorbed Dose in Radiation-Hardness Testing of Electronic Devices²

F 526 Test Method for Measuring Dose for Use in Linear Accelerator Pulsed Radiation Effects Tests³

3. Terminology

3.1 Definitions:

3.1.1 *dose rate*—energy absorbed per unit time and per unit mass by a given material from the radiation to which it is exposed.

3.1.2 *dose rate response*—the change that occurs in an observed characteristic of an operating linear integrated circuit induced by a radiation pulse of a given dose rate.

4. Summary of Practice

4.1 The test device and suitable dosimeters are irradiated by a pulse from either an FXR or a LINAC while the test device is operating under agreed-upon conditions. The responses of the test device and of the dosimeters are recorded.

4.2 The response of the test device to dose rate is recorded over a specified dose rate range.

4.3 A number of factors are not defined in this practice, and must be agreed upon beforehand by the parties to the test.

4.3.1 Total dose limit (see 1.3),

4.3.2 Electrical parameters of the test device whose responses are to be measured (see 10.10),

4.3.3 Temperature at which the test is to be performed (see 6.7),

4.3.4 Details of the test circuit, including output loading, power supply levels, and other operating conditions (see 7.4 and 10.3),

4.3.5 Choice of radiation pulse source (see 6.9 and 7.9),

4.3.6 Pulse width (see 6.9 and 7.9.2),

4.3.7 Sampling (see 8.1),

4.3.8 Need for total dose measurement (see 6.10, 7.8, and 10.1.1),

4.3.9 An irradiation plan which includes the dose rate range and the minimum number of dose rate values to be used in that range (see 10.6 and 10.9), and

4.3.10 Appropriate functional test (see 10.4 and 10.8).

¹ This practice is under the jurisdiction of ASTM Committee F01 on Electronics and is the direct responsibility of Subcommittee F01.11 on Quality and Hardness Assurance.

Current edition approved June 10, 1996. Published August 1996. Originally published as F 773 – 82. Last previous edition F 773 – 92.

² *Annual Book of ASTM Standards*, Vol 12.02.

³ *Annual Book of ASTM Standards*, Vol 10.04.

5. Significance and Use

5.1 There are many kinds of linear integrated circuits. Any given linear integrated circuit may be used in a variety of ways and under various operating conditions within the limits of performance specified by the manufacturer. The procedures of this practice provide a standardized way to measure the dose-rate response of a linear integrated circuit, under operating conditions similar to those of the intended application, when the circuit is exposed to pulsed ionizing radiation.

5.2 Knowledge of the responses of linear integrated circuits to radiation pulses is essential for the design, production, and maintenance of electronic systems that are required to operate in the presence of pulsed radiation environments.

6. Interferences

6.1 *Air Ionization*—A spurious component of the signal measured during a test can result from conduction through air ionized by the radiation pulse. Such spurious contributions can be checked by measuring the signal while irradiating the test fixture in the absence of a test device. Air ionization contributions to the observed signal are generally proportional to applied field, while those due to secondary emission effects (6.2) are not. The effects of air ionization external to the device may be minimized by coating exposed leads with a thick layer of paraffin, silicone rubber, or nonconductive enamel, or by making the measurement in a vacuum.

6.2 *Secondary Emission*⁴—Another spurious component of the measured signal can result from charge emission from, or charge injection into, the test device and test circuit. This may be minimized by shielding the surrounding circuitry and

irradiating only the minimum area necessary to ensure irradiation of the test device. Reasonable estimates of the expected magnitude of current resulting from secondary-emission effects can be made based on the area of metallic target materials irradiated.

NOTE 1—For dose rates in excess of 10^8 Gy (Si)/s the photocurrents developed by the package may dominate the device photocurrent. Care should be taken in the interpretation of the measured photoresponse for these high dose rates.

Values of current density per unit dose rate generally range between 10^{-11} and 10^{-10} A/cm² per Gy/s. The use of a scatter plate (7.9.2) may increase these values.

6.3 *Orientation*—The effective dose to a semiconductor junction can be altered by changing the orientation of the test device with respect to the irradiating beam. Most integrated circuits may be considered “thin samples” (in terms of the range of the radiation). However, some devices may have cooling studs or thick-walled cases that can act to scatter the incident beam, thereby modifying the dose received by the semiconductor chip. Position such devices carefully with the die normal to the beam.

6.4 *Dose Enhancement*—High atomic number materials near the active regions of the integrated circuit (package, metallization, die attach materials, etc.) can deliver an enhanced dose to the sensitive regions of the device when it is irradiated with an FXR. The possibility and extent of this effect should be considered.

6.5 *Electrical Noise*—Since radiation test facilities are inherent sources of r-f noise, good noise-minimizing techniques such as singlepoint ground, filtered dc supply lines, etc., must be used in these measurements (see Fig. 1).

⁴ Sawyer, J. A., and van Lint, V. A. J., “Calculations of High-Energy Secondary Electron Emission,” *Journal of Applied Physics*, Vol 35, No. 6, June 1964, pp. 1706–1711.

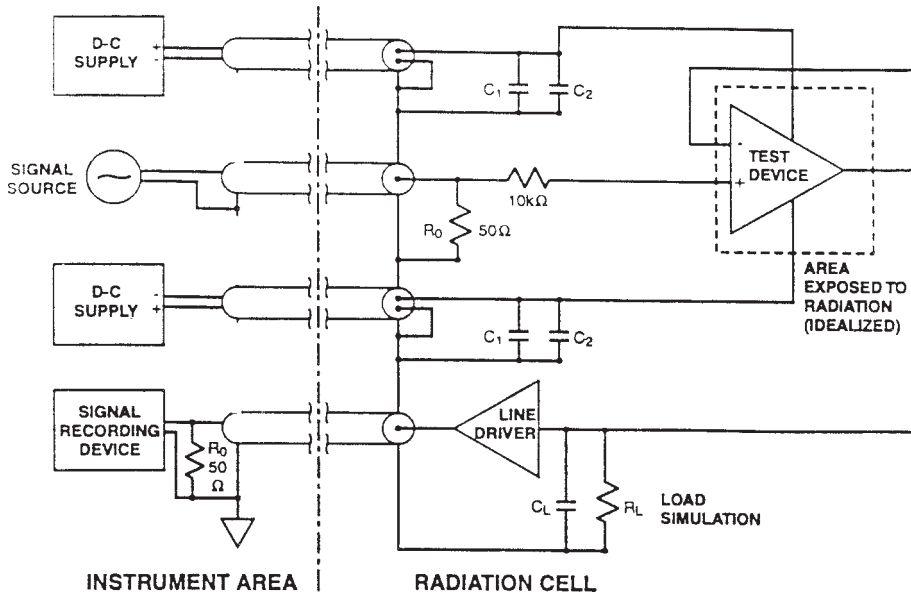

FIG. 1 Example of a Test Circuit

6.6 *Dosimetry*—Accurate, reproducible calibration of dose-rate monitors is difficult. For this reason, dosimetry is apt to provide the single most substantial source of error in dose-rate determinations.

6.7 *Temperature*—Device characteristics are dependent on junction temperature; hence, the temperature of the test should be controlled. Unless otherwise agreed upon by the parties to the test, measurements will be made at room temperature ($23 \pm 5^\circ\text{C}$).

6.8 *Beam Homogeneity and Pulse-to-Pulse Repeatability*—The intensity of a beam from an FXR or a LINAC is likely to vary across its cross section. Since the pulse-shape monitor is placed at a different location than the device under test, the measured dose rate may be different from the dose rate to which the device was exposed. The spatial distribution and intensity of the beam may also vary from pulse to pulse. The beam homogeneity and pulse-to-pulse repeatability associated with a particular radiation source should be established by a thorough characterization of its beam prior to performing a measurement.

6.9 *Pulse Width*—The response observed in a dose rate test may be dependent on the width of the radiation pulse. This fact must be considered when selecting a radiation source, or when comparing data taken at different times or at different radiation test facilities.

6.10 *Total Dose*—Each pulse of the radiation source imparts a dose to both the device under test and the device used for dosimetry. The total dose accumulated in a semiconductor device will cause permanent damage which can change its operating characteristics. As a result, the response that is measured after several pulses may be different from that characteristic of an unirradiated device. Care should be exercised to ensure that the total dose delivered to the test device is less than the agreed-upon maximum value. Care must also be taken to ensure that the characteristics of the dosimeter have not changed due to the accumulated dose.

7. Apparatus

7.1 *Regulated DC Power Supplies* with floating outputs to produce the voltages required to bias the integrated circuit under test.

7.2 *Recording Devices*, such as oscilloscopes equipped with cameras, transient digitizers with appropriate displays, or other suitable instruments. The bandwidth capabilities of the recording devices shall be such that the radiation responses of the integrated circuit and the pulse-shape monitor (7.6) are accurately displayed and recorded.

NOTE 2—Depending on the kind of measurement, dc instruments, spectrum analyzers, current transformers, or other instruments may be required to measure and record the response of the test device.

7.3 *Cabling* to complete adequately the connection of the test circuit in the exposure area with the power supply and recording devices in the data area. Shielded twisted pair or coaxial cables may be used to connect the power supplies to the bias points of the test circuit; however, coaxial cables properly terminated at the recording device inputs are required for the signal leads.

7.4 *Test Circuit*, as shown in Fig. 1. Although the details of test circuits for this test must vary depending on the kind of electronic component tested and on the specific electrical parameters of the test device to be measured, the example of Fig. 1 provides the information necessary for the design of a test circuit for most purposes. The capacitor, C_1 (typically 10 μF), provides an instantaneous source of current as may be required by the test device during the radiation pulse. Its value must be large enough that the decrease in the supply voltage during a pulse is less than 10 %. Capacitor C_1 should be paralleled by a small (approximately 0.1 μF) low-inductance capacitor, C_2 , to ensure that possible inductive effects of the large capacitor are offset. Both capacitors must be located as close to the test device as possible, consistent with the space needed for any shielding that may be necessary. The arrangement of the grounding connections provides that no ground loops and only one ground exists. This reduces both the possibility of ground loops and common-mode signals present at the terminals of the measurement instruments. The resistors, R_0 , are terminations for the coaxial cables, and have values within 2 % of the characteristic impedances of their respective cables. All unused inputs to the test device are connected as agreed upon by the parties to the test. The output(s) of the test device may be loaded, as agreed upon by the parties to the test. To prevent loading of the output of the test device by the coaxial cable, line drivers having a high input impedance and adequate bandwidth, linearity, and dynamic range may be used to reproduce accurately at the output end of the coaxial cable the waveforms appearing at the line driver inputs.

7.5 *Signal Sources*, as required to provide the agreed-upon operating conditions of the test device and to perform suitable functional tests.

7.6 *Radiation Pulse-Shape Monitor*—One of the following to develop a signal proportional to the dose rate delivered to the test device.

7.6.1 *Fast Signal-Diode* in the circuit configuration of Fig. 2. The resistors, R_1 , serve as high frequency isolation and must be at least 20 Ω . The capacitor, C_1 (typically 10 μF), supplies the charge during the current transient; its value must be large enough that the decrease in voltage during a current pulse is less than 10 %. Capacitor C_1 should be paralleled by a small (approximately 0.1 μF) low-inductance capacitor, C_2 , to ensure that possible inductive effects of the large capacitor are offset. The resistor, R_0 , is to provide the proper termination (within $\pm 2\%$) for the coaxial cable used for the signal lead. This is the preferred apparatus for this purpose.

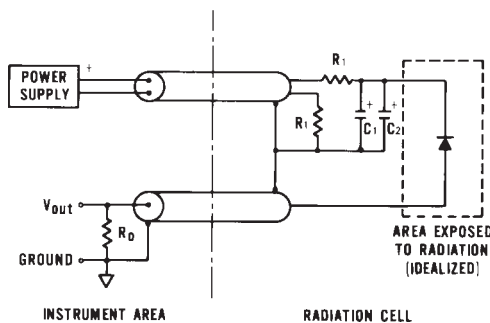

FIG. 2 Irradiation Pulse-Shape Monitor Circuit for Diodes

7.6.2 *P-I-N Diode* in the circuit configuration of Fig. 2 (7.6.1). Care should be taken to avoid saturation effects at high dose rates and R-C charging effects at low dose rates.

7.6.3 *Current Transformer*, mounted on a collimator at the output window of the linear accelerator so that the primary electron beam passes through the opening of the transformer after passing through the collimator. The current transformer must have a bandwidth that accurately displays the current signal. The low frequency cutoff of some commercial current transformers is such that significant droop may occur for pulse widths greater than 1 μ s. Do not use a transformer for which this droop is greater than 5 % for the radiation pulse width used. When monitoring large currents, do not exceed the current-time saturation rating of the current transformer. It may be required that the signal cable monitoring the current transformer be matched to the characteristic impedance of the transformer; R_0 would then have this impedance (within ± 2 %), as specified by the manufacturer of the current transformer.

NOTE 3—Because the radiation beam from an FXR is a photon beam rather than an electron beam, a current transformer cannot be used as a pulse-shape monitor with an FXR.

7.6.4 *Secondary-Emission Monitor* consisting of a thin foil, biased negatively with respect to ground, mounted in an evacuated chamber with thin windows through which the primary radiation beam passes after passing through a collimator. A resistor in series with the foil and bias supply is used to sense the current.

7.7 *Dosimeter*—One of the following types to calibrate the output of the pulse-shape monitor in terms of dose rate.

7.7.1 *Commercial Thermoluminescent Dosimeter (TLD)*—and readout system.

7.7.2 *Thin Calorimeter* and associated strip-chart recorder and preamplifier as defined in Test Method F 526.

7.8 *Total Dose Dosimeter*—The TLD of 7.7.1 is to be used for determining, when required, the total dose to which the test device is exposed (see 4.3.8).

7.9 *Radiation Pulse Source*—One of the following machines:

7.9.1 *Flash X-Ray Machine (FXR)*, used in the photon mode, and capable of delivering a peak dose rate sufficient for the test.

NOTE 4—The use of an FXR at end point energy below 2 MeV is not recommended. If such use is required, care must be taken to account for dosimetry problems arising from dose-enhancement effects.

7.9.2 *Electron Linear Accelerator (LINAC)*, producing pulses of electrons with energies between 10 and 50 MeV in pulses with a width within the range agreed upon by the parties to the test. The primary electron beam is used as the ionizing source. A thin scatter plate of a material with low atomic number, such as aluminum, 0.15 to 0.65 cm thick, may be placed at the exit window of the linear accelerator to spread the beam and somewhat homogenize it so that positioning of the test device is not as critical as it would be if the beam were unscattered.

NOTE 5—**Caution:** There is approximately 5 MeV/cm energy attenuation of the beam passing through aluminum.

7.10 *Resistive Network*, designed to simulate the integrated circuit impedances, for use in evaluating the spurious responses of the test circuit. The network should present impedances to the power supply, input, and output connections of the integrated circuit socket in the test circuit which approximate the active impedances of the integrated circuit type to be tested.

7.11 *Temperature-Measuring Device* to measure ambient temperature in the vicinity of the device under test to $\pm 1^\circ\text{C}$.

8. Sampling

8.1 This method determines the properties of a single specimen. If sampling procedures are used to select devices for test, the procedures shall be agreed upon between the parties to the test.

9. Preparation of Apparatus

9.1 Select an appropriate test circuit and align it with the beam of the radiation source. Position the scatter plate and appropriate shielding, collimation, and pulse-shape monitor.

9.2 Determine the dose-rate factor for calibration of the pulse-shape monitor by the procedure of 9.2.1 if an FXR is to be used, or by either the procedure of 9.2.1 or 9.2.2 if a LINAC is to be used.

9.2.1 *Thermoluminescent Dosimeter (TLD)*—Mount the TLD in the position to be occupied by the test device. Pulse the radiation source and record the pulse-shape monitor signal. Remove the TLD and determine the dose following the manufacturer's instructions. Integrate the irradiation pulse-shape monitor signal and calculate a dose-rate factor as follows:

$$F = \gamma/\Sigma \quad (1)$$

where:

F = dose-rate factor, Gy(Si)/V·s,

γ = dose, Gy(Si), and

Σ = integrated pulse-shape monitor signal, V·s.

Repeat the measurement five times and average. Use this value for the dose-rate factor.

NOTE 6—The use of Practice E 668 is recommended to obtain the best precision in the measurement of the dose-rate factor when TLDs are used.

9.2.2 *Thin Calorimeter*—Mount the calorimeter in the position to be occupied by the test device. Provide thermal isolation for the calorimeter foil. Pulse the radiation source; record the pulse-shape monitor signal on film and the temperature rise of the calorimeter on the strip-chart recorder. Calculate the dose delivered from the temperature rise as follows:

$$\gamma = \Delta T c_p \quad (2)$$

where:

γ = dose, Gy (calorimeter material),

ΔT = temperature rise, $^\circ\text{C}$, and

c_p = specific heat at constant pressure of calorimeter material, J/(kg·K).

Integrate the irradiation pulse-shape monitor signal and calculate a dose-rate factor from Eq 1. Repeat the measurement five times and average. Use this value for the dose-rate factor.

NOTE 7—The use of Test Method F 526 is recommended to obtain the best precision in the measurement of the dose-rate factor when a LINAC is used.

9.3 Measure the test circuit with device removed. With the resistive network in the test circuit, apply the bias to be used (10.3) and pulse the radiation source to deliver a dose rate within the specified dose-rate range (4.3.9). Record both the irradiation pulse-shape monitor signal and the signal from the test circuit. The measured signal should be less than or equal to one-tenth the anticipated transient signal. If it is, proceed with the test (Section 10). If it is not, change the bias and repeat. If the signal changes (indicating air-ionization problems), pot the exposed leads of the test circuit (6.1). If the signal is still large and affected little by the applied bias, restrict still further the exposure area and increase the shielding of the test circuit, or remove the scatter plate, or both, and repeat the measurement. Continue in this manner until a signal of one tenth the anticipated transient signal or less is obtained. Record the actual values measured and the changes made.

10. Procedure

10.1 Mount the test device in the test circuit.

10.1.1 Install a fresh TLD adjacent to the test device, if total dose recording is required (4.3.8).

10.2 Measure and record the ambient temperature in the vicinity of the test device.

10.3 Apply power supply voltage(s) to the test device at level(s) agreed upon by the parties to the test.

10.4 Perform the agreed-upon functional test (4.3.10) to ensure that the test device is operational.

10.5 Apply any required signals to the inputs of the test device.

10.6 Adjust the radiation source to the initial dose-rate value, and record both the irradiation pulse-shape monitor signal and the signals from the test circuit as required.

10.6.1 When necessary, determine the dose rate by multiplying the dose-rate factor (9.2) by the voltage of the radiation pulse-shape monitor (7.6).

10.7 Record the response which has occurred.

10.8 Perform the agreed-upon functional test to ensure that the test device is still operational.

10.9 Adjust the dose rate received by the test device upwards in accordance with the agreed-upon irradiation plan (4.3.9), until the maximum dose rate is reached, repeating 10.6 through 10.8 at each dose rate level.

10.10 If responses have been specified for more than one electrical parameter of the test device, either repeat 10.6-10.9 for each or add instrumentation to allow simultaneous measurement of all of the parameters whose response is to be determined.

10.11 If required, record the total dose to which the test device was exposed (10.1.1).

11. Report

11.1 Report the following for each device tested.

11.1.1 Device identification, including type number, date code, and manufacturer,

11.1.2 Date of test and name of test operator,

11.1.3 Identification of radiation pulse source, pulse width, test port, FXR output voltage, or LINAC electron energy.

11.1.4 Description of scatter plate, if used,

11.1.5 Description of test circuit,

11.1.6 Description of radiation pulse-shape monitor,

11.1.7 Dosimetry technique,

11.1.8 Test-circuit responses with resistive network in place (see 9.3),

11.1.9 Steady-state operating conditions of the test device,

11.1.10 Functional test used,

11.1.11 Records of circuit responses for each electrical parameter which was examined,

11.1.12 Record of the irradiation pulse-shape monitor,

11.1.13 Total dose, if required, and

11.1.14 Ambient temperature.

12. Keywords

12.1 circuit response; dose rate; integrated circuit; ionizing radiation; linear circuits; linear integrated circuits; pulsed radiation; transient response

ASTM International takes no position respecting the validity of any patent rights asserted in connection with any item mentioned in this standard. Users of this standard are expressly advised that determination of the validity of any such patent rights, and the risk of infringement of such rights, are entirely their own responsibility.

This standard is subject to revision at any time by the responsible technical committee and must be reviewed every five years and if not revised, either reapproved or withdrawn. Your comments are invited either for revision of this standard or for additional standards and should be addressed to ASTM International Headquarters. Your comments will receive careful consideration at a meeting of the responsible technical committee, which you may attend. If you feel that your comments have not received a fair hearing you should make your views known to the ASTM Committee on Standards, at the address shown below.

This standard is copyrighted by ASTM International, 100 Barr Harbor Drive, PO Box C700, West Conshohocken, PA 19428-2959, United States. Individual reprints (single or multiple copies) of this standard may be obtained by contacting ASTM at the above address or at 610-832-9585 (phone), 610-832-9555 (fax), or service@astm.org (e-mail); or through the ASTM website (www.astm.org).