



Designation: D 3263—82 (Reapproved 1999)<sup>ε1</sup> 3263 – 03

## Standard Test Methods for Corrosivity of Solvent Systems for Removing Water-Formed Deposits<sup>1</sup>

This standard is issued under the fixed designation D 3263; the number immediately following the designation indicates the year of original adoption or, in the case of revision, the year of last revision. A number in parentheses indicates the year of last reapproval. A superscript epsilon (ε) indicates an editorial change since the last revision or reapproval.

---

<sup>ε1</sup> ~~Note—A footnote was editorially removed in June 1999.~~

---

### 1. Scope

1.1 These test methods cover the determination of corrosivity of solvent systems used to remove water-formed deposits from the metal and alloy surfaces of water handling equipment. Four test methods are given as follows:

Test Method A—Corrosivity in the Absence of Deposits	Sections 10 to 15
Test Method B—Corrosivity in the Presence of Selected Ions	16 to 21
Test Method C—Corrosivity with Magnetite-Coated Steel Specimens	22 to 28
Test Method D—Corrosivity with Deposit-Coated Specimens	29 to 35

1.2 Test Methods A and B provide for corrosivity testing under either static immersion or dynamic conditions.

1.3 Test Methods C and D are procedures applicable for corrosivity testing under static immersion conditions only.

1.4 *This standard does not purport to address all of the safety concerns, if any, associated with its use. It is the responsibility of the user of this standard to establish appropriate safety and health practices and determine the applicability of regulatory limitations prior to use.*

### 2. Referenced Documents

2.1 *ASTM Standards:*

---

<sup>1</sup> These test methods are under the jurisdiction of ASTM Committee D-19 on Water and are the direct responsibility of Subcommittee D19.03 on Sampling of Water and Water-Formed Deposits, ~~Surveillance Analysis of Water; for Power Generation and Flow Measurement Process Use, On-Line Water Analysis, and Surveillance of Water.~~

Current edition approved May 28, 1982; Aug. 10, 2003. Published October 1982; September 2003. Originally published as D 3263—73 F, approved in 1973. Last previous edition approved in 1999 as D 3263 – 7782 (1999)<sup>ε1</sup>.

D 1129 Terminology Relating to Water<sup>2</sup>

D 1193 Specification for Reagent Water<sup>2</sup>

D 2790 Test Methods of Analysis of Solvent Systems Used for Removal of Water-Formed Deposits<sup>3</sup>

### 3. Terminology

#### 3.1 Definitions:

3.1.1 For definitions of terms used in these test methods, refer to Definitions D 1129.

#### 3.2 Definitions of Terms Specific to This Standard:

3.2.1 *solvent system*—specified chemicals or combinations of chemicals, which may include corrosion inhibitors designed to react with and remove deposits.

### 4. Summary of Test Methods

4.1 These test methods consist of procedures wherein the corrosivity of solvent systems is determined by the weight loss experienced by metal specimens during exposure to the solvent systems.

4.2 Test Method A is a procedure to determine corrosivity from the weight loss of metal specimens during exposure to solvent systems in the absence of deposits. This corrosivity can be determined by either static immersion or dynamic techniques.

4.3 Test Method B provides the determination in solvent systems that have had selected ions added. It describes techniques for manufacturing the solvent with the desired ions and refers to Test Method A for the actual corrosivity testing.

4.4 Test Method C describes the techniques used to produce magnetited specimens that are subsequently used for the determination of the corrosivity of the solvent system.

4.5 Test Method D describes the techniques used to produce specimens coated with a synthetic deposit that are subsequently used for the determination of the corrosivity of the solvent system.

### 5. Significance and Use

5.1 Test Method A is necessary because the corrosivity of a solvent system can be detrimental to the equipment being cleaned. It is used to compare the corrosivity of various solvent systems and to determine the corrosivity of selected solvent systems under different conditions.

5.2 Test Method B is necessary because the corrosivity of a solvent system can be changed by the presence of ions in the solvent system. It is used to determine if the ions that might be present during a cleaning operation would significantly change the corrosivity of a solvent system.

5.3 Test Method C is necessary because the corrosivity of a solvent system under magnetite removal conditions can be different from the corrosivity in the absence of deposit. It is used to determine the corrosivity of the solvent system under magnetite removal conditions.

5.4 Test Method D is necessary because the presence or absence of deposits may affect the corrosivity of the solvent system. It is used to determine the corrosivity of solvent systems on deposit-coated specimens. These results are compared with results obtained from Test Method A to determine the effect of the deposit.

### 6. Specimen Composition and Size

6.1 Test specimens for Test Methods A, B, and C may be flat coupons, either rectangular or circular in shape, or rod or tubular material. Regardless of form, finish all specimens to a size, including edges or ends, of 38.7 cm<sup>2</sup> (6 in.<sup>2</sup>). Prepare coupon or rod specimens from hot- or cold-rolled stock, either ferrous or nonferrous, having a composition acceptable to all interested parties. Take tubular specimens from cold-drawn stock of appropriate composition; the inside diameter shall be no less than 12.7 mm (0.5 in.). Steel specimens only are used in Test Method C.

6.2 Circular coupon specimens only are used in Test Method D. They shall conform to all conditions prescribed in 6.1 except that the size shall be such that one side provides the test area of 38.7 cm<sup>2</sup> (6 in.<sup>2</sup>).

### 7. Specimen Preparation

7.1 Prepare four specimens of whatever form for each test condition.

#### 7.2 Coupon Specimens:

7.2.1 Cut specimens by sawing, abrasive cut-off, or milling (shearing is not permissible). Any such power-cutting operation must include adequate cooling to prevent metallurgical changes that might result from excessive heating. Perform final mechanical finishing of the specimens, with 120-grit silicon carbide cloth. Round all edges and corners lightly. Sand blasting for finishing is not permissible. For ferrous specimens the alternative use of microglass bead blasting is permissible.

7.2.2 Drill a 3.2-mm (0.125-in.) hole near the top of rectangular specimens and through the center of circular test pieces for suspension in the solvent.

<sup>2</sup> Annual Book of ASTM Standards, Vol 11.01.

<sup>3</sup> Discontinued. See 1992 Annual Book of ASTM Standards, Vol 11.02.

7.2.3 Mark specimens for identification by an engraving tool. (Do not identify specimens by stamping.)

7.2.4 Final preparation of the specimens shall be as follows:

7.2.4.1 *Ferrous Specimens:*

- (1) Degrease by immersion in ~~acetone-n-hexane~~.
- (2) Pickle with uninhibited hydrochloric acid (HCl, 1 + 1) at room temperature for 10 min.
- (3) Neutralize by immersion in hot saturated sodium bicarbonate (NaHCO<sub>3</sub>) solution.
- (4) Rinse with water.
- (5) ~~Dry with acetone~~. Dry.

7.2.4.2 *Nonferrous and Stainless Steel Specimens:*

- (1) Degrease by immersion in ~~acetone-n-hexane~~.
- (2) Scrub with household cleanser containing no oxidizing agents.
- (3) Rinse with water.
- (4) ~~Dry with acetone~~. Dry.

7.2.4.3 Handle the specimens only with tongs or suitable plastic gloves during this cleaning and drying period as well as all other operations until after the final weighing following exposure to the test solvent.

7.2.4.4 Weigh each specimen to  $\pm 1.0$  mg after cooling and store in a desiccator until ready for use. Recheck after storage for constant weight.

7.3 *Rod-Type Specimens:*

7.3.1 Size specimens to 12.7-mm (0.5-in.) diameter with the end rounded to a 6.35-mm (0.25-in.) radius. Perform all cutting and sizing operations by lathe turning, grinding, or milling, with adequate cooling to prevent metallurgical changes due to excessive heating. Perform final mechanical finishing of the specimen with 120-grit silicon carbide cloth.

7.3.2 Drill a 3.2-mm (0.125-in.) hole into the axial center line of one end and attach a polypropylene rod section for suspension of the specimen in the solvent with epoxy cement.

7.3.3 Mark the specimens for identification as in 7.2.3.

7.4 *Tubular Specimens:*

7.4.1 Perform all cutting operations by lathe turning, sawing, reaming, etc. with adequate cooling to prevent metallurgical changes. Finish both the external and internal surfaces of the tubing. Do final mechanical finishing of the specimen with 120-grit silicon carbide cloth.

7.4.2 Drill a 3.2-mm (0.125-in.) hole in each specimen near one end for suspension in the solvent.

7.4.3 Mark the specimens for identification as in 7.2.3.

7.4.4 Clean and weigh specimens as specified in 7.2.4.

## 8. Reagents and Materials

8.1 *Purity of Reagents:*

8.1.1 All solvent materials such as acids, inhibitors, and other additives shall be of commercial or technical grade, such as would normally be employed in chemical cleaning practices for the removal of water-formed deposits.

8.1.2 Reagent grade chemicals shall be used for cleaning test specimens, for addition of selected ions to solvent systems (Test Method B), preparing synthetic deposits (Test Method D), or analyzing a solvent for active components or water-formed deposit constituents. Unless otherwise indicated, it is intended that all reagents shall conform to the specifications of the Committee on Analytical Reagents of the American Chemical Society, where such specifications are available.<sup>4</sup>

8.2 *Purity of Water*— Unless otherwise indicated, references to water shall be understood to mean reagent water, conforming to Specification D 1193, Type III.

8.3 *Reagents for Cleaning Specimens :*

8.3.1 ~~Acetone (CH<sub>3</sub>COCH<sub>3</sub>)-N-Hexane~~.

8.3.2 *Hydrochloric Acid* (1 + 1)—Carefully add 1 volume of hydrochloric acid (HCl, sp gr 1.19) to volume of water.

8.3.3 *Methyl Alcohol* (CH<sub>3</sub>OH), absolute.

8.3.4 *Sodium Bicarbonate Solution* (100 g/L)—Dissolve 100 g of sodium bicarbonate (NaHCO<sub>3</sub>) in water and dilute solution to 1 L.

## 9. Hazards

9.1 This standard may involve the use of hazardous materials, operations, and equipment. It is the responsibility of whoever uses this standard to establish appropriate safety practices and to determine the applicability of regulatory limitations prior to use.

<sup>4</sup> *Reagent Chemicals, American Chemical Society Specifications*, American Chemical Society, Washington, DC. For suggestions on the testing of reagents not listed by the American Chemical Society, see *Analar Standards for Laboratory Chemicals*, BDH Ltd., Poole, Dorset, U.K., and the *United States Pharmacopeia and National Formulary*, U.S. Pharmaceutical Convention, Inc. (USPC), Rockville, MD.

TEST METHOD A—CORROSIVITY IN THE ABSENCE OF DEPOSITS

10. Scope

10.1 This test method covers the determination of corrosivity of solvent systems used to remove water-formed deposits from metal and alloy surfaces. It provides for corrosivity testing in the absence of deposit.

10.2 It provides for corrosivity testing under static immersion and dynamic conditions.

11. Summary of Test Method

11.1 This test method provides procedures for determining the corrosivity of diverse solvent systems used for the removal of water-formed deposits under three sets of conditions as follows:

- 11.1.1 Testing by static immersion of specimens in the solvent,
- 11.1.2 Testing under velocity conditions resulting from the flow of fluid past the specimens, and
- 11.1.3 Testing under velocity conditions resulting from the rotation of the specimens in the solvent.

11.2 The weight loss of the specimens is determined after a 6-h contact period. Other parameters such as possible solvent composition and concentration, temperature, and addition of inhibitors cover a range that cannot be standardized. Each test must be defined in terms of these variables as mutually agreed upon by all interested parties. The following temperature ranges are suggested when acidic solvents are used:

- 11.2.1 *Nonferrous Alloys*—37.8 to 65.6°C (100 to 150°F).
- 11.2.2 *Ferrous Alloys*— 65.6 to 93.3°C (150 to 200°F).

11.3 Specimens for static immersion or flowing stream testing are rectangular or circular, flat coupons, rods, or tubular shapes as described in Section 6. For rotating specimen testing only the rod form is used. In all cases specimens are prepared as prescribed in Section 7.

12. Apparatus

12.1 *For Static Immersion Testing :*

12.1.1 *Constant-Temperature Bath*, thermostatically controlled to  $\pm 1.1^\circ\text{C}$  ( $2^\circ\text{F}$ ) and provided with suitable openings and supports for the test containers.

12.1.2 *Test Containers*— 500-mL, tall form, lipless polypropylene beakers. They shall be fitted with tight covers.

12.2 *For Testing Under Fluid Flow Velocity Conditions:*

12.2.1 *Test Loop for Circulating Solvent* (Fig. 1), containing provisions for solvent temperature control  $\pm 1.1^\circ\text{C}$  ( $2^\circ\text{F}$ ), flow control, and by-pass flow during temperature adjustment.

12.2.2 *Flow Chamber Assembly* (Fig. 2 and Fig. 3), with mounts for coupon, rod, and tubular specimens.

12.3 *For Testing Under Rotating Specimen Velocity Conditions:*

- 12.3.1 *Constant-Temperature Bath*—See 12.1.1.
- 12.3.2 *Apparatus for Rotation of Rod-Type Specimens* (Fig. 4).

13. Procedure

13.1 Prepare the test solvents using a weight-percent basis for the acid or other active material, including any additives. Only inhibitors supplied in liquid form shall be added on a volume basis prescribed by the manufacturer. The quantity of solvent prepared for static immersion and rotating specimen conditions shall be sufficient to fill essentially all test containers using four for each type of specimen-solvent combination. For fluid flow testing prepare a quantity of solvent equal to 150 % of the volume of the circulating system plus 150 mL for each specimen exposed.

13.2 *Static Immersion Test:*

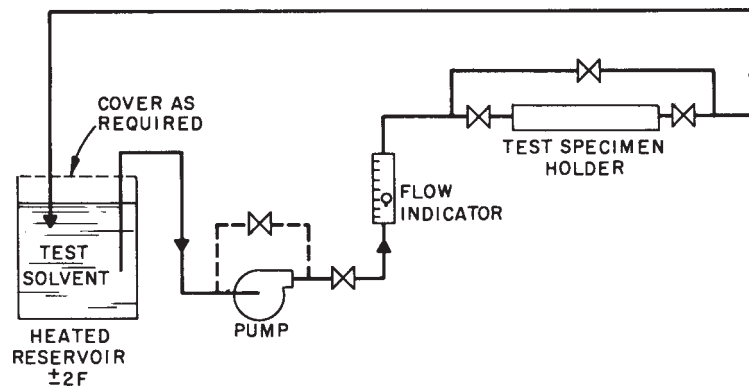

FIG. 1 Circulating Test Loop (Nonmetallic Construction)

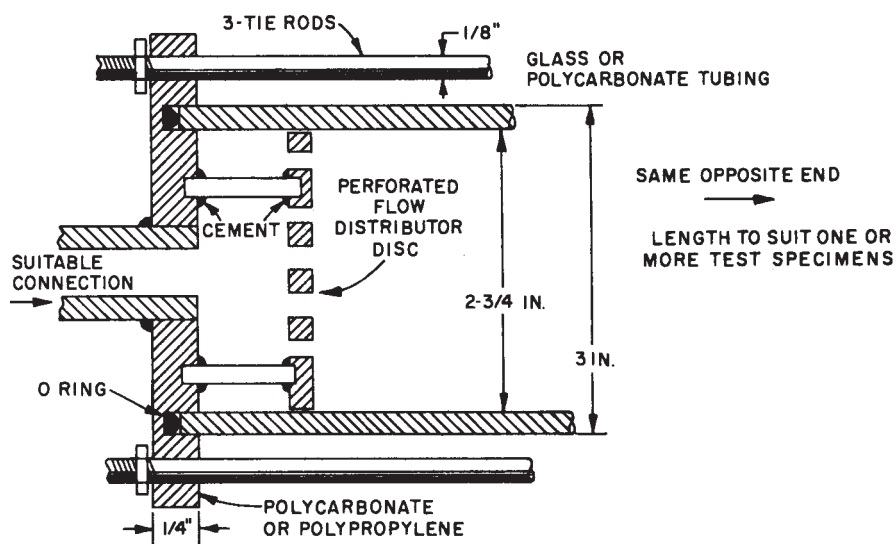

FIG. 2 Flow Chamber Test Assembly

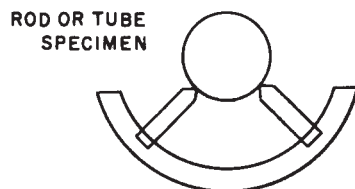
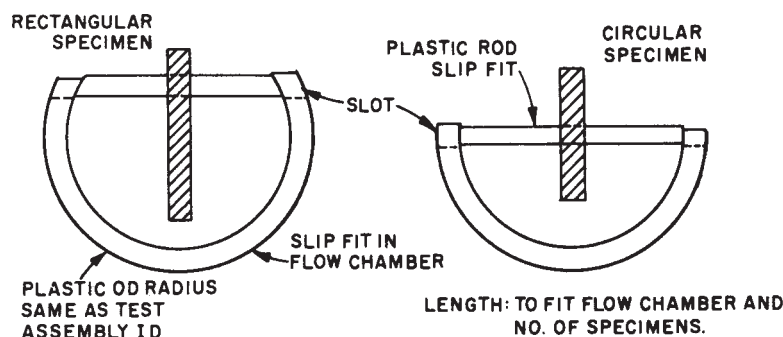

FIG. 3 Specimen Mounts for Flow Chamber

13.2.1 Pour 450 mL of solvent into each test beaker (12.1.2) and place in the constant-temperature bath (12.1.1) that has been preheated to the selected test temperature. Cover the containers to avoid excessive evaporation and loss of volatile solvent components.

13.2.2 When the solvent temperature has reached that of the bath, totally immerse the test specimens, one to a container. Suspend the specimen in the solvent by a plastic-coated wire or glass hook in such a manner that contact with the container wall is avoided.

13.2.3 After a contact period of 6 h, remove the specimens and thoroughly rinse in a stream of water. Scrub the specimens with a pumice-type soap and water, using a tooth brush, or equivalent. Rinse with water, absolute methyl alcohol, and acetone, in that order, air dry, and weigh. Store in a desiccator and recheck to constant weight.

13.3 Fluid Flow Test:

13.3.1 Fill the circulating system (Fig. 1) with solvent, start circulation, and heat, adjusting the temperature to the prescribed value.

13.3.2 When the temperature of the solvent has reached the desired temperature, mount the specimen holder. More than one specimen may be inserted in series in the test loop provided they are suitably insulated from each other. Do not test dissimilar metals at the same time.

13.3.3 Adjust the flow rate of 61 cm/s (2 ft/s) past the specimens. Other flow rates may be used by agreement when it is desired to study the effects of varying the velocity.

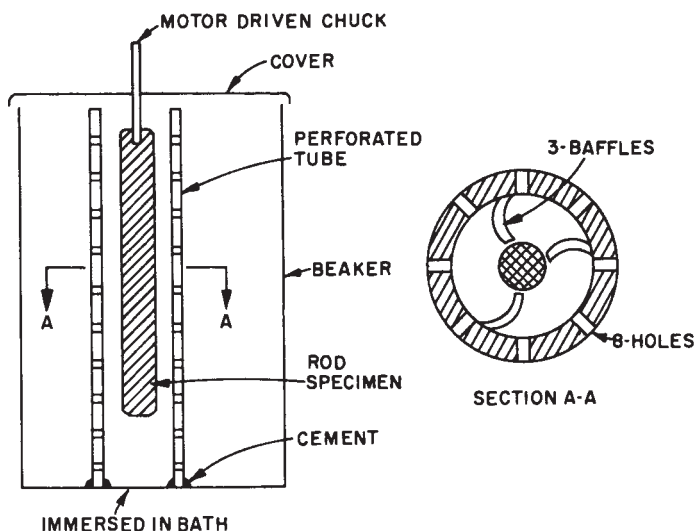

FIG. 4 Apparatus for Rod Rotation

13.3.4 After a period of 6 h stop the circulation and remove the specimens from the solvent. Rinse, clean, and weigh in accordance with 13.2.3.

13.4 *Rotating Specimen Test:*

13.4.1 Pour sufficient solvent into each test container (Fig. 4) to cover the specimen fully and place in the constant-temperature bath (12.1.1), which has been adjusted to the prescribed temperature. Cover the beakers to avoid excessive evaporation and loss of volatile constituents.

13.4.2 When the solvent in the containers has reached the prescribed temperature, submerge the specimens, connect each to a motor driven chuck, and rotate at 920 r/min approximating a surface velocity of 61 cm/s (2 ft/s). Other rotational rates may be used by agreement and expressed as equivalent velocities.

13.4.3 After a 6-h contact period remove the specimens. Rinse, clean, and weigh as directed in 13.2.3.

13.5 For additional information, the solvent concentration at the end of the test period and the amounts of any corrosion products may be determined by the appropriate procedures given in Test Methods D 2790.

**14. Report**

14.1 Report the corrosion rate as the milligram weight loss per 6 h. Use the average of four specimens to establish the reported value.

14.2 Also report the test conditions such as the temperature, volume, and composition of the solvent, and velocity of solvent flow, if any. In the case of rotating rod-type specimens report the velocity equivalent to specimen rotational speed.

14.3 Report and describe any condition of nonuniform corrosion such as pitting.

14.4 Report the analysis of the spent solvent if one was made giving the concentrations of both solvent constituents and corrosion products.

**15. Quality Control**

15.1 The method calls for the testing of four specimens for each material. This is two sets of duplicates, so single operator precision can be estimated on a limited basis.

15.2 A blank specimen that goes through each step except the solvent exposure should also occur with each material tested.

**16. Precision and Bias**

15.1 ~~Because of the numerous variables involved such as the number of alloys~~

16.1 ~~Precision and number of solvents, no statement can be made regarding the precision of bias have not been determined for this test method. The user is cautioned to select test conditions as close as possible to actual system conditions.~~

**TEST METHOD B—CORROSIVITY IN THE PRESENCE OF SELECTED IONS IN THE SOLVENT**

**16. Scope**

16.1 ~~This test method covers the determination of the corrosivity of solvent systems with the addition of selected ions to the solvent system.~~

~~16.2 It provides for corrosivity testing under static immersion and dynamic conditions. SOLVENT~~

## 17. Scope

~~17.1 This test method covers the determination of the corrosivity of solvent systems with the addition of selected ions to the solvent system.~~

~~17.2 It provides for corrosivity testing under static immersion and dynamic conditions.~~

## 18. Summary of Test Method

~~178.1 This test method provides procedures for determining the corrosivity of solvent systems used for the removal of water-formed deposits when selected ions typical of solubilized deposit constituents are present in the solvent. The weight loss of coupon, rod, or tubular specimens cut, finished, and prepared as directed in Sections 6 and 7 is determined after a 6-h contact period with the solvent. The choice of specimen composition and form, test temperature, and solvent composition (except for the added ions) are described in Section 11 for either static immersion or dynamic (fluid flow or rotating specimen) testing. These parameters must be defined for each test as agreed upon by all interested parties.~~

~~178.2 The effects of either cations or anions when present in solvent systems may be evaluated by this test method. The selected ions should be those present and common in water-formed deposits, the total concentrations of cations or anions, or both, added to the system should be 1 % or as otherwise mutually agreed upon.~~

~~178.2.1 Added cations may be any of the following either singly or in combination, as agreed upon:~~

<del>Al<sup>+++</sup></del> <del>Ca<sup>++</sup></del> <del>Cr<sup>+++</sup></del> <del>Cu<sup>++</sup></del> <del>Fe<sup>++</sup></del>	<del>Fe<sup>+++</sup></del> <del>Mg<sup>++</sup></del> <del>Mn<sup>++</sup></del> <del>Ni<sup>++</sup></del> <del>Zn<sup>++</sup></del>
--	---

~~For acidic solvents, cations are added preferably as the carbonate or hydroxide and are compatible with the solvent with respect to complete solubility. Such additions will reduce the acid concentration. This level is restored or not depending upon the purpose of the test and the agreement between the interested parties.~~

~~178.2.2 The anions found in water-formed deposits are limited, the common ones that can be added to solvent systems being:~~

~~PO<sub>4</sub><sup>---</sup>~~  
~~SiO<sub>2</sub><sup>---</sup>~~  
~~SO<sub>4</sub><sup>---</sup>~~  
~~S<sup>---</sup>~~

~~The anions are added preferably as the sodium or ammonium salt and are completely soluble in the solvent system.~~

## 18. Apparatus

~~18.1 The apparatus required for dynamic immersion, flowing fluid, or rotating specimen testing conditions, shall be referred to in 12.1, 12.2, and 12.3, respectively.~~

## 19. Procedure

~~19.1 Prepare the test solvents using a weight-percent basis Apparatus~~

~~19.1 The apparatus required for the acid or other active materials, including any additives (inhibitors) and the appropriate chemicals for supplying the selected ions found in solutions of water-formed deposits (see Section 17). The concentration of total added cations or anions, or both, shall be 1 % unless otherwise agreed upon. The quantity of the solvent prepared shall be as defined in 13.1.~~

~~19.2 Except for the inclusion of selected ions in the solvent system this test method is the same as Test Method A. For a description of the test procedures for static dynamic immersion, flowing fluid, or rotating specimen testing conditions, shall be referred to 13.2, 13.3, in 12.1, 12.2, and 13.4, 12.3, respectively.~~

~~19.3 For additional information on solvent concentrations or the amounts of corrosion products present in the solvent at the end of the test follow the appropriate procedures in Test Methods D 2790.~~

## 20. Report

~~20.1 Report Procedure~~

~~20.1 Prepare the corrosion rate as test solvents using a weight-percent basis for the milligram weight loss per 6 h. Use acid or other active materials, including any additives (inhibitors) and the average appropriate chemicals for supplying the selected ions found in solutions of water-formed deposits (see Section 18). The concentration of total added cations or anions, or both, shall be 1 % unless otherwise agreed upon. The quantity of the reported value.~~

~~20.2 Also report the test conditions such solvent prepared shall be as defined in 13.1.~~

~~20.2 Except for the temperature, volume, composition inclusion of solvent, velocity of selected ions in the solvent flow if any, and quantity system this test method is the same as Test Method A. For a description of added cation(s) the test procedures for static immersion, flowing fluid, or anion(s), or both. For rotating rod specimens the velocity equivalent to specimen rotational speed shall be reported.~~

~~20.3 Report testing, refer to 13.2, 13.3, and describe any condition 13.4, respectively.~~

~~20.3 For additional information on solvent concentrations or the amounts of nonuniform corrosion such as pitting.~~

~~20.4 Report also products present in the results solvent at the end of any analyses made on the spent solvent. test follow the appropriate procedures in Test Methods D 2790.~~

## **21. Report**

~~21.1 Report the corrosion rate as the milligram weight loss per 6 h. Use the average of four specimens to establish the reported value.~~

~~21.2 Also report the test conditions such as the temperature, volume, composition of solvent, velocity of solvent flow if any, and quantity of added cation(s) or anion(s), or both. For rotating rod specimens the velocity equivalent to specimen rotational speed shall be reported.~~

~~21.3 Report and describe any condition of nonuniform corrosion such as pitting.~~

~~21.4 Report also the results of any analyses made on the spent solvent.~~

## **22. Quality Control**

~~22.1 The method calls for the testing of four specimens for each material. This is two sets of duplicates, so single operator precision can be estimated on a limited basis.~~

~~22.2 A blank specimen that goes through each step except the solvent exposure should also occur with each material tested.~~

## **23. Precision and Bias**

~~21.1 Because of the numerous variables involved in~~

~~23.1 Precision and bias have not been determined for this procedure no statement can be made regarding the precision of this test method. method. The user is cautioned to select test conditions as close as possible to actual system conditions.~~

## **TEST METHOD C—CORROSIVITY WITH MAGNETITE-COATED STEEL SPECIMENS**

## **224. Scope**

~~224.1 This test method covers the determination of the corrosivity of solvent systems under static immersion magnetite removal conditions.~~

## **235. Summary of Test Method**

~~235.1 This test method provides a procedure for determining the corrosivity of solvent systems used for the removal of water-formed deposits by static immersion of steel specimens artificially coated with magnetite. The weight loss of coupon, rod, or tubular specimens is determined after a 6-h contact period. The choice of the steel alloy specimen form, test temperature, and solvent composition and concentration are described in Section 11. These parameters are defined for each test as agreed upon by the interested parties.~~

## **246. Apparatus**

~~246.1 For the constant-temperature bath and test containers required for this test method see Section 12.~~

## **257. Test Specimens**

~~257.1 All specimens shall be steel of an agreed upon composition. They may be coupon, rod, or tubular in form and shall be sized, finished, and prepared (prior to oxidation) as directed in Sections 6 and 7.~~

~~257.2 Coat the weighed specimens of the selected composition and form with magnetite using the following technique:~~

~~257.2.1 Hang the specimens in an enclosed stainless steel box provided with inlet and outlet tubes. Insert the assembly into a muffle furnace adjusted to 566°C (1050°F) ±10°C with the tubes extended outside the furnace.~~

~~257.2.2 Flow steam at atmosphere pressure through the box containing the specimens at a rate sufficient to obtain a visible plume at the outlet of the box. Bubble air into the flask used for steam generation at a rate to give a barely discernible stream of bubbles from a submerged tube. Continue the steam-air oxidation treatment for a 6-h period.~~

~~257.2.3 After removal and cooling in a desiccator, reweigh the specimens and record the gain in weight due to oxidation × 0.72 representing the amount of iron oxidized. Store in a desiccator.~~

## **268. Procedure**

~~268.1 The procedure for this test method shall be the same as that described in 13.1 and 13.2 except that all specimens shall be magnetite-coated steel (see Section 18).~~

~~27. 27).~~

## **29. Report**

~~279.1 Record the total weight loss as milligram loss per 6 h using the average of four specimens.~~



279.2 Report the corrosion rate in milligrams as:

$$\text{Total weight loss} - (\text{weight gain after oxidation} \times 0.72)$$

279.3 Report and describe any condition of nonuniform corrosion such as pitting.

279.4 Report any other observations such as sloughing of the oxide scale and whether complete dissolution of adherent or sloughed scale occurs.

279.5 In the event the oxide scale is not completely removed by the solvent, corrosion rate measurement is not possible.

### 30. Quality Control

30.1 The method calls for the testing of four specimens for each material. This is two sets of duplicates, so single operator precision can be estimated on a limited basis.

30.28 A blank specimen that goes through each step except the solvent exposure should also occur with each material tested.

### 31. Precision and Bias

~~28.1 Because of the nature of this procedure~~

31.1 Precision and the variables involved no statement can be made concerning the precision of Bias have not been determined for this method. The user is cautioned to select test conditions as close as possible to actual system conditions.

## TEST METHOD D—CORROSIVITY WITH DEPOSIT-COATED SPECIMENS

### 329. Scope

329.1 This test method covers the determination of the corrosivity of solvent systems under static immersion conditions on deposit-coated specimens.

### 303. Summary of Test Method

303.1 This test method provides a procedure for determining the corrosivity of solvent systems used for the removal of water-formed deposits with specimens coated with a synthetic deposit of prescribed composition. The weight loss of coated, flat, or circular specimens is determined after a 6-h static immersion contact period. Other parameters such as solvent composition and concentration, test temperature, use of inhibitors, and chemicals for the synthetic deposit(s) cannot be standardized. Each test must be defined with respect to these variables as agreed upon by all interested parties.

303.2 The synthetic deposits are preferably from laboratory reagents such as those listed below, either singly or in combination, as agreed upon:

Calcium carbonate	CaCO <sub>3</sub>
Calcium sulfate	CaSO <sub>4</sub>
Calcium phosphate	Ca <sub>3</sub> (PO <sub>4</sub> ) <sub>2</sub>
Calcium silicate	CaSiO <sub>3</sub>
Copper (metallic)	Cu
Copper oxide	Cu <sub>2</sub> O
Ferric oxide	Fe <sub>2</sub> O <sub>3</sub> ·H <sub>2</sub> O
Ferrous-ferric oxide (magnetite)	Fe <sub>3</sub> O <sub>4</sub>
Magnesium hydroxide	Mg(OH) <sub>2</sub>
Magnesium silicate	Mg <sub>2</sub> SiO <sub>4</sub>
Manganese dioxide	MnO <sub>2</sub>

### 314. Apparatus

314.1 For the constant-temperature bath and test containers required for this test method, see 12.1.

### 325. Test Specimens

325.1 The specimens for this test method shall be flat, circular coupons having an area *on one side only* of 38.7 cm<sup>2</sup> (6 in.<sup>2</sup>). Except for size they shall conform to all conditions described in 4.1 and be finished and prepared as instructed in 5.1 and 5.2, omitting the final weighing.

325.2 Coat each specimen on one side only with a synthetic deposit of the agreed composition using the following technique:

325.2.1 Completely coat the specimen, including the edges and mounting hole interior, with an epoxy-tar type material by either spraying or dipping. The coating should have a thickness of 5 to 8 mils.

325.2.2 Air dry the coated specimen as directed by the coating manufacturer and then oven dry for 1 h at 100°C (212°F).

325.2.3 Immerse the specimen in the solvent under test for 6 h at the test temperature. Remove from the solution and rinse with water. Oven dry at 100°C (212°F) for 1 h to bring the coating to an initial equilibrium.

325.2.4 Remove the epoxy-tar coating from one surface only (upper side) using an abrasive belt or disk taking care to minimize any metal removal.

325.2.5 Weigh the specimen to ±1.0 mg after carefully wiping to remove all dust.

325.2.6 Coat the exposed metal surface of the specimen with the synthetic deposit to a depth of 2.5 mm (0.1 in.) and air dry.

325.2.6.1 The deposit constituent(s) (see 303.2) shall be applied as a thick paste of minus 300-mesh material (well mixed, if more than one) in water.

325.3 Mount the specimens as shown in Fig. 5.

**336. Procedure**

336.1 Prepare the test solvents on a weight-percent basis as directed in 13.1, the quantity being sufficient to fill one container (four specimens) for each solvent-specimen coating combination.

336.2 Place the containers appropriately filled with solvent in a constant-temperature bath that has been preheated to the desired temperature.

336.3 When the temperature of the solvent reaches that of the bath, totally immerse the test specimen assemblies, one to a container. Specimens with coatings of different compositions shall not be tested in the same portions of solvent.

336.4 After a contact period of 6 h, remove the specimens, scrub the deposit contact surface with a pumice-type soap and water. Then rinse with water followed by oven drying at 100°C (212°F). Weigh to ± 1.0 mg and store in a desiccator and recheck for constant weight.

**347. Report**

347.1 Report the corrosion rate as milligram weight loss per 6 h. Use the average of four specimens to establish the reported value.

347.2 Report also the test conditions such as temperature, volume, composition of solvent, and composition of deposit.

347.3 Report and describe any condition of nonuniform corrosion such as pitting and attack at the protective coating edge.

**358. Quality Control**

38.1 The method calls for the testing of four specimens for each material. This is two sets of duplicates, so single operator precision can be estimated on a limited basis.

38.2 A blank specimen that goes through each step except the solvent exposure should also occur with each material tested.

**39. Precision and Bias**

35.1 Because of the nature of this procedure

39.1 Precision and the variables involved, no statement can be made concerning the precision involved. Bias have not been determined for this method. The user is cautioned to select test conditions as close as possible to actual system conditions.

*ASTM International takes no position respecting the validity of any patent rights asserted in connection with any item mentioned in this standard. Users of this standard are expressly advised that determination of the validity of any such patent rights, and the risk of infringement of such rights, are entirely their own responsibility.*

*This standard is subject to revision at any time by the responsible technical committee and must be reviewed every five years and if not revised, either reapproved or withdrawn. Your comments are invited either for revision of this standard or for additional standards and should be addressed to ASTM International Headquarters. Your comments will receive careful consideration at a meeting of the responsible technical committee, which you may attend. If you feel that your comments have not received a fair hearing you should make your views known to the ASTM Committee on Standards, at the address shown below.*

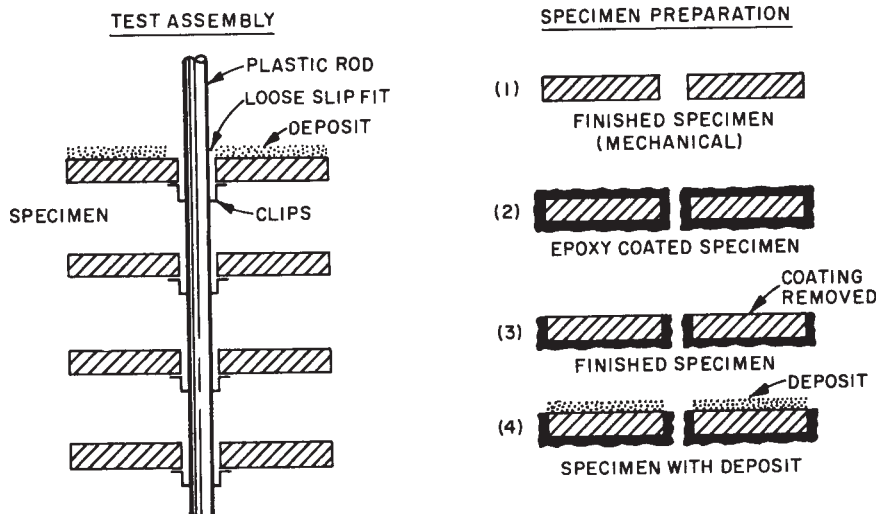



FIG. 5 Test Assembly for Synthetic Deposits

 **D-3263 – 82 (1999)<sup>e1</sup> 3263 – 03**

*This standard is copyrighted by ASTM International, 100 Barr Harbor Drive, PO Box C700, West Conshohocken, PA 19428-2959, United States. Individual reprints (single or multiple copies) of this standard may be obtained by contacting ASTM at the above address or at 610-832-9585 (phone), 610-832-9555 (fax), or [service@astm.org](mailto:service@astm.org) (e-mail); or through the ASTM website ([www.astm.org](http://www.astm.org)).*