



Designation: D 3863 – 87 (Reapproved 1998)

## Standard Test Method for Retention Characteristics of 0.40 to 0.45- $\mu\text{m}$ Membrane Filters Used in Routine Filtration Procedures for the Evaluation of Microbiological Water Quality<sup>1</sup>

This standard is issued under the fixed designation D 3863; the number immediately following the designation indicates the year of original adoption or, in the case of revision, the year of last revision. A number in parentheses indicates the year of last reapproval. A superscript epsilon ( $\epsilon$ ) indicates an editorial change since the last revision or reapproval.

### 1. Scope

1.1 This test method covers a procedure to test membrane filters for their ability to retain bacteria whose diameter is equal to or slightly larger than membrane filters with pore size rated at 0.40 to 0.45  $\mu\text{m}$ .

1.2 The procedures described are for the use of user laboratories as differentiated from manufacturers' laboratories.

1.3 *This standard does not purport to address all of the safety problems, if any, associated with its use. It is the responsibility of the user of this standard to establish appropriate safety and health practices and determine the applicability of regulatory limitations prior to use.*

### 2. Referenced Documents

2.1 *ASTM Standards:*

D 1129 Terminology Relating to Water<sup>2</sup>

D 1193 Specification for Reagent Water<sup>2</sup>

### 3. Terminology

3.1 *Definitions:*

3.1.1 For definitions of terms used in this method refer to Terminology D 1129.

3.2 *Definitions of Terms Specific to This Standard:*

3.2.1 *Gram's stain*—a routine bacterial stain that divides bacteria into two categories, depending on whether they can be decolorized with acetone, alcohol, or aniline oil after staining with one of the rosaniline dyes such as crystal violet, methyl violet, or gentian violet and treating with iodine. Those that resist decolorization remain blue or violet and are designated Gram-positive; those that are decolorized and take up the red counterstain, such as neutral red, safranin, or dilute carbol fuchsin are termed Gram-negative.

3.2.2 *vacuum*—for the procedure used, a source of suction that can produce a reading of 500 to 600 mm Hg on a vacuum gage.

### 4. Summary of Test Method

4.1 This test method is based on the cultivation of organisms whose diameters are equal to or slightly larger than pores of the membrane filter to be tested and then filtering a specific aliquot containing organisms through the membrane followed by an examination of the filtrate after incubation for sterility. A sterile filtrate indicates complete retention of the organism and validates the ability of the membrane to retain bacteria equal to or slightly larger than the stated pore size.

### 5. Significance and Use

5.1 Microbiological water testing procedures using membrane filtration are based on the premise that all bacteria within a specific size range will be retained by the membrane filter used. If the membrane filter does not retain these bacteria, false negative results or lowered density estimates may occur that could have serious repercussions due to the presence of unrecognized potential health hazards in the water being tested, especially in drinking water.

5.2 This procedure as devised will enable the user to test each membrane filter lot number for its ability to retain all bacteria equal to, or larger than, the stated membrane pore size.

### 6. Apparatus

6.1 *Membrane Filtration Units*, six.

6.2 *Vacuum Source* with trap vessel.

6.3 *Filtering Flasks*, 1-L, with vacuum tubing into which a glass tube and a Y-tube have been incorporated as in Fig. 1. The free end of the Y-tube is connected by tubing to a sterile bacterial air vent. The tubing to air vent is clamped shut during filtration and released after filtration.

6.4 *Forceps*, blunt-nosed, and small beaker of 95 % ethanol.

6.5 *Incubator*, 20 to 25°C.

6.6 *Pinch-Cock Clamps*.

6.7 *Autoclave or Other Sterilizing Equipment*.

6.8 *Appropriate Equipment* for producing reagent grade water.

6.9 *Appropriate Laboratory Glassware*.

6.10 *Sterile Rubber Stoppers*, to fit 1-L filtering flask.

6.11 *Expendables:*

6.11.1 *Double-Strength Broth*, 140-mL aliquots.

<sup>1</sup> This test method is under the jurisdiction of ASTM Committee D-19 on Water and is the direct responsibility of Subcommittee D19.08 on Membranes and Ion Exchange Materials.

Current edition approved March 27, 1987. Published July 1987.

<sup>2</sup> 1983 Annual Book of ASTM Standards, Vol 11.01.

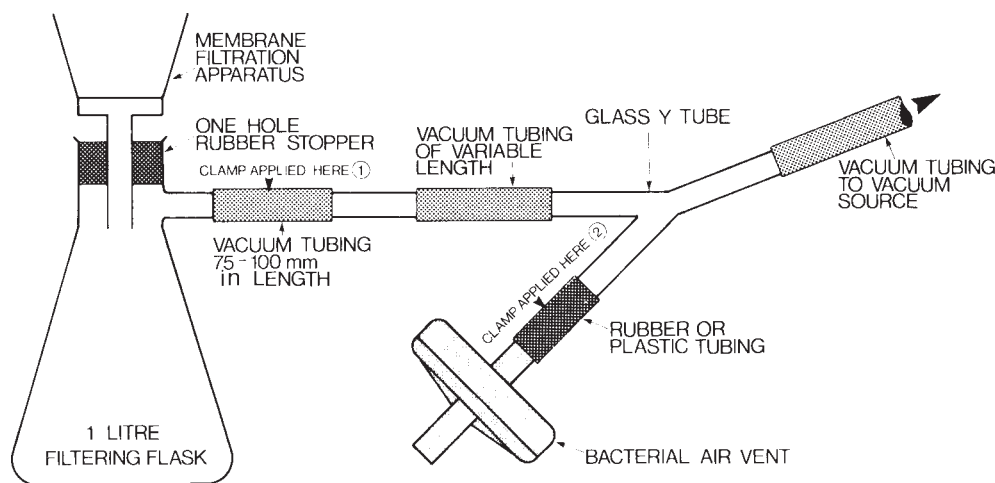

FIG. 1 Apparatus Required for Testing Retention Characteristics of Membrane Filters

- 6.11.2 Sterile Pipets, 1 and 10-mL.
- 6.11.3 Sterile 0.1 % Peptone in 99-mL quantities.
- 6.11.4 Sterile 0.1 % Peptone as rinse water.
- 6.11.5 Broth Cultures of *Serratia marcescens*,  $18 \pm 2$  h.
- 6.11.6 Sterile Membrane Filters—Test membranes.
- 6.11.7 Petri Dishes, 50-mm, containing 6 to 8-mL of agar.

## 7. Reagents and Materials

7.1 *Purity of Reagents*—Reagent grade chemicals shall be used in all tests. Unless otherwise indicated, it is intended that all reagents shall conform to the specifications of the Committee on Analytical Reagents of the American Chemical Society, where such specifications are available.<sup>3</sup> Other grades may be used, provided it is first ascertained that the reagent is of sufficiently high purity to permit its use without lessening the accuracy of the determination.

7.2 *Purity of Water*—Unless otherwise indicated, reference to water shall be understood to mean reagent water conforming to Specification D 1193, Type II, with 0.2- $\mu$ m membrane filtration. In addition, suitability tests for determining the bactericidal properties of the reagent grade water should be performed.

7.3 *Bacterial Suspension*—Add 1 mL of an  $18 \pm 2$ -h broth culture of *Serratia marcescens* to 99 mL of 0.1 % peptone water, to obtain a working concentration of approximately  $10^3$  to  $10^4$  organisms per millilitre. Prepare five bottles. Incubator temperature of suspension is 25°C.

7.4 *Peptone Water (0.1 %)*—Prepare a 10 % stock solution of peptone in water. Dilute a measured volume of the 10 % stock solution to obtain final solution of 0.1 % peptone in required amount. Sterilize at 121°C for 15 min.

7.5 *Test Organism*—*Serratia marcescens* ATCC strain 14756, also called FDA strain PC1 1107. Red pigmented *Serratia marcescens* strains other than the above may also be used.

7.6 *Tryptic Soy Agar and Tryptone Soya Agar*—are interchangeable and henceforth referred to as agar medium, formulated, prepared, and dispensed in accordance with the manufacturers' specifications.

7.7 *Tryptone Soya and Tryptic Soy Broth*—are interchangeable and henceforth referred to as broth medium, formulated, prepared, and dispensed in accordance with the manufacturers' specifications.

## 8. Procedure

8.1 Place 140 mL of double-strength broth into six 1-L vacuum flasks with the attached vacuum tubing, Y-tube, and bacterial air vent. Wrap in kraft paper and sterilize by autoclaving at 121°C for 15 min.

8.2 Aseptically assemble membrane filtration apparatus onto each flask, connect to the vacuum source, and aseptically place the test membrane filter into the a filter holder and secure. Place the clamp on tubing between the Y-tube and sterile bacterial air vent.

8.3 Pour the culture suspension (100 mL) into a filter funnel and turn on the vacuum.

8.4 After the suspension has been filtered, wash down the sides of the funnel with two 20-mL peptone water rinses and immediately turn off the vacuum when the last drop of peptone water has been filtered. Release the clamp between Y-tube and bacterial air vent to allow air in the flask to equilibrate. After equilibration has taken place, place the clamp on the vacuum tubing in front of the glass tube at point (1) and remove the glass tube and the rest of vacuum tubing.

8.5 Repeat the process using sterile equipment and sterile 0.1 % peptone as a negative control inoculum.

8.6 Aseptically remove the membrane filtration apparatus and place the sterile stopper in the flask and then incubate the stoppered flask for 48 h at 25°C.

8.7 Using flamed forceps, aseptically remove the membrane from the membrane-filter holder and place a filter on agar (50-mm petri dish) for 48 h at 25°C and check the membranes for growth outside of filtering area. Growth outside of the filtering area will indicate a faulty filtering apparatus and may result in a false positive test.

<sup>3</sup> *Reagent Chemicals, American Chemical Society Specification*, American Chemical Society, Washington, DC. For suggestions on the testing of reagents not listed by the American Chemical Society, see *Analar Standards for Laboratory Chemicals*, BDH Ltd., Poole, Dorset, UK, and the *United States Pharmacopoeia and National Formulary*, U.S. Pharmaceutical Convention, Inc. (USPC), Rockville, MD.



## D 3863

8.8 Note any signs of turbidity in the liquid medium as an indication of growth and thus failure of the membrane to retain bacteria larger than 0.45  $\mu\text{m}$ . Confirm turbid broths by streaking to an agar plate and check for strain purity. Apply Gram's stain test and perform biochemical tests if in doubt.

8.9 Examine control broth culture after 48 h. If any sign of turbidity occurs, this indicates technique failure and the test and control procedures should be repeated.

8.10 Test a minimum of five randomly selected membranes from five randomly selected packages. Take the control membrane from the same package as one of the test membranes.

## 9. Precision and Bias

9.1 Since this is a positive or negative test, precision and bias statements are not applicable to this procedure.

## 10. Keywords

10.1 filter; membrane; microbiological; water quality

## ANNEX

### (Mandatory Information)

#### A1. INTERPRETATION OF TEST RESULTS

A1.1 *Failures in Retention of Test Organism*—The appearance of test organisms downstream of the test membrane filter in a retention test may be due to one or more of three possible factors: (1) inherent failure of the membrane, (2) failure of the membrane filtration unit to form a proper seal, or damage to the membrane from improper handling during the test. Before concluding that a membrane filter is inherently faulty, items (2) and (3) must be considered as possible causes of an apparent failure.

A1.2 *Membrane Filtration Apparatus*—The performance of equipment used to evaluate membrane filters for bacterial

retention should be examined prior to its use. Membrane filtration units that employ a positive seal such as those fitted with a sealing O-ring are ideal for this application. Once equipment is qualified to ensure proper sealing, it may then be reserved exclusively for membrane-retention testing.

A1.3 *Damage Due to Improper Handling*—Exercise care at all times when manipulating dry membranes. While handling with smooth-tip filter forceps, examine membranes visually prior to testing. Discard any filters showing visible flaws such as cracked edges or holes.

*The American Society for Testing and Materials takes no position respecting the validity of any patent rights asserted in connection with any item mentioned in this standard. Users of this standard are expressly advised that determination of the validity of any such patent rights, and the risk of infringement of such rights, are entirely their own responsibility.*

*This standard is subject to revision at any time by the responsible technical committee and must be reviewed every five years and if not revised, either reapproved or withdrawn. Your comments are invited either for revision of this standard or for additional standards and should be addressed to ASTM Headquarters. Your comments will receive careful consideration at a meeting of the responsible technical committee, which you may attend. If you feel that your comments have not received a fair hearing you should make your views known to the ASTM Committee on Standards, at the address shown below.*

*This standard is copyrighted by ASTM, 100 Barr Harbor Drive, PO Box C700, West Conshohocken, PA 19428-2959, United States. Individual reprints (single or multiple copies) of this standard may be obtained by contacting ASTM at the above address or at 610-832-9585 (phone), 610-832-9555 (fax), or service@astm.org (e-mail); or through the ASTM website (www.astm.org).*