



# Standard Test Methods for Operating Characteristics of Reverse Osmosis Devices<sup>1</sup>

This standard is issued under the fixed designation D 4194; the number immediately following the designation indicates the year of original adoption or, in the case of revision, the year of last revision. A number in parentheses indicates the year of last reapproval. A superscript epsilon ( $\epsilon$ ) indicates an editorial change since the last revision or reapproval.

## 1. Scope

1.1 These test methods cover the determination of the operating characteristics of reverse osmosis devices using standard test conditions and are not necessarily applicable to natural waters. Two test methods are given, as follows:

	Sections
Test Method A—Brackish Water Reverse Osmosis Devices	8-13
Test Method B—Seawater Reverse Osmosis Devices	14-19

1.2 *This standard does not purport to address all of the safety concerns, if any, associated with its use. It is the responsibility of the user of this standard to establish appropriate safety and health practices and determine the applicability of regulatory limitations prior to use.*

## 2. Referenced Documents

### 2.1 ASTM Standards:

- D 512 Test Methods for Chloride Ion in Water<sup>2</sup>
- D 1125 Test Methods for Electrical Conductivity and Resistivity of Water<sup>2</sup>
- D 1129 Terminology Relating to Water<sup>2</sup>
- D 1193 Specification for Reagent Water<sup>2</sup>

## 3. Terminology

3.1 *Definitions*—For definitions of terms used in these test methods, refer to Terminology D 1129.

### 3.2 Definitions of Terms Specific to This Standard:

- 3.2.1 *concentrate, reject, or brine*—that portion of feed which does not pass through the membrane.
- 3.2.2 *conversion or recovery*—the ratio of permeate flow rate to feed flow rate, expressed as percent.
- 3.2.3 *desalination device*—a single pressure vessel containing a reverse osmosis element or elements and supporting materials.
- 3.2.4 *device pressure drop ( $\Delta P$ )*—the difference between the feed pressure and the concentrate pressure.
- 3.2.5 *feed*—the solution that enters the device.
- 3.2.6 *permeate*—that portion of the feed which passes

through the membrane.

3.2.7 *permeate flow rate*—the quantity of permeate produced per unit time.

3.2.8 *rejection*—that portion of the salt in the feed which does not pass through the reverse osmosis membrane, expressed as percent and is equal to (100 % – salt passage).

3.2.9 *salt passage*—the ratio of permeate salt concentration to feed salt concentration, expressed as percent.

## 4. Summary of Test Methods

4.1 These test methods consist of determining the desalinating ability and permeate flow rate of reverse osmosis devices. They are applicable to both new and used reverse osmosis devices.

## 5. Significance and Use

5.1 Reverse osmosis desalinating devices can be used to produce potable water from brackish supplies (<10 000 mg/L) and seawater as well as to upgrade the quality of industrial water. These test methods permit the measurement of the performance of reverse osmosis devices using standard sets of conditions and are intended for short-term testing (<24 h). These test methods can be used to determine changes that may have occurred in the operating characteristics of reverse osmosis devices but are not intended to be used for plant design.

## 6. Reagents

6.1 *Purity of Reagents*—Reagent grade chemicals shall be used in all tests. Unless otherwise indicated, it is intended that all reagents shall conform to the specifications of the Committee on Analytical Reagents of the American Chemical Society, where such specifications are available.<sup>3</sup> Other grades may be used, provided it is first ascertained that the reagent is of sufficiently high purity to permit its use without lessening the accuracy of the determination.

6.2 *Purity of Water*—Unless otherwise indicated, references to water shall be understood to mean Type III reagent conforming to Specification D 1193.

<sup>1</sup> These test methods are under the jurisdiction of ASTM Committee D-19 on Water, and are the direct responsibilities of Subcommittee D19.08 on Membranes and Ion Exchange Materials.

Current edition approved April 15, 1995. Published June 1995. Originally published as D 4194 – 82. Last previous edition D 4194 – 89 (1994).

<sup>2</sup> *Annual Book of ASTM Standards*, Vol 11.01.

<sup>3</sup> *Reagent Chemicals, American Chemical Society Specifications*, American Chemical Society, Washington, DC. For suggestions on the testing of reagents not listed by the American Chemical Society, see *Analar Standards for Laboratory Chemicals*, BDH Ltd., Poole, Dorset, U.K., and the *United States Pharmacopoeia and National Formulary*, U.S. Pharmaceutical Convention, Inc. (USPC), Rockville, MD.

**7. Apparatus**

7.1 The apparatus for both methods is schematically described in Fig. 1 and Fig. 2. A conductivity meter can be used to determine the salt concentration in accordance with Test Methods D 1125.

*7.2 Installation:*

7.2.1 Materials of construction shall be of high-quality stainless steel (Type 316) or plastic for all wetted parts to prevent contamination of the feed solution by corrosion products. Do not use reactive piping material such as plain carbon steel, galvanized or cadmium-plated carbon steel, and cast iron for piping. Take care to ensure that no contamination will occur from oil films on new metal piping, release agents on raw plastic components, or from feed solutions previously used in the system. If materials are suspect, thoroughly clean or

degrease or both, before use. All pressurized components whether stainless steel or plastic should be designed based on the manufacturer's working pressure rating. Review manufacturer's rating for compliance with standard engineering practice.

7.2.2 The reverse osmosis testing apparatus, represented schematically in Fig. 1 using a centrifugal pump, consists of a feed holding tank equipped with a thermostated heat exchanger system to maintain the feed solution at the desired temperature, a booster pump, a high-pressure centrifugal pump, and a reverse osmosis device. Use a valve with a minimum flow restriction (for example, ball valve or plug valve) for the shut-off valve to prevent excessive pressure drop. The filter can be either a strainer (100-mesh) or a 5- $\mu$ m filter (based on supplier's recommendation). Use a pressure control

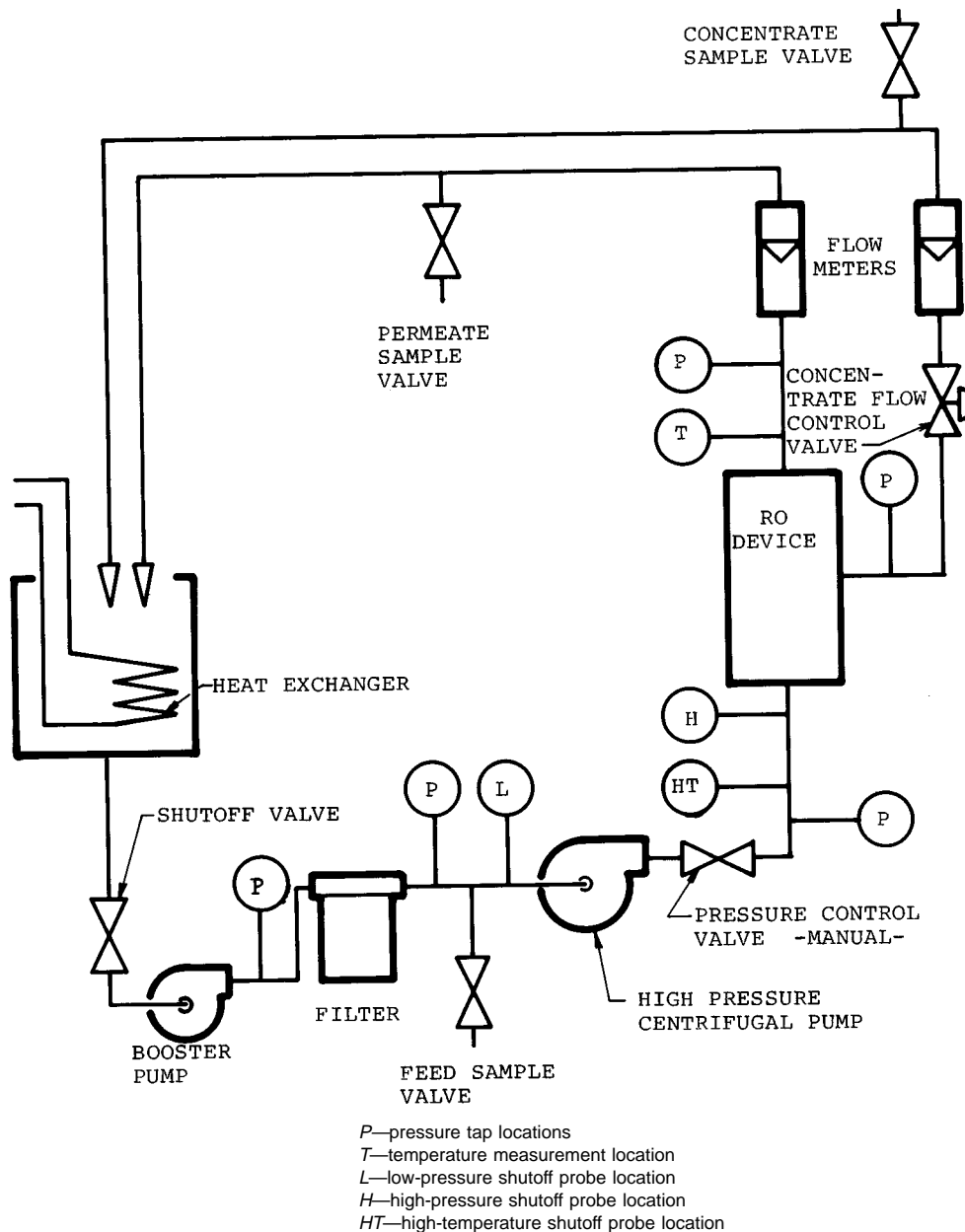

**FIG. 1 Centrifugal High-Pressure Pump System Piping Diagram**

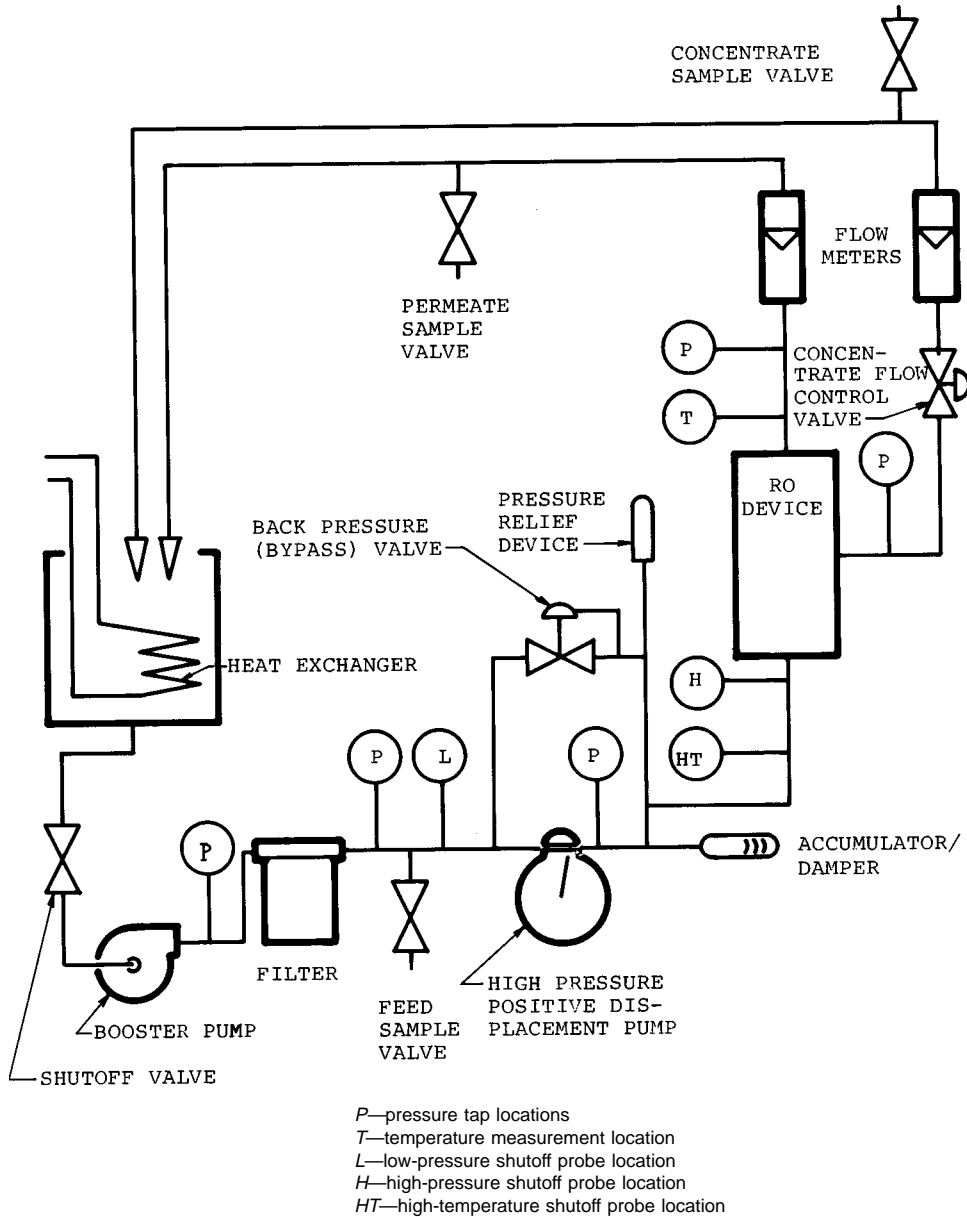

FIG. 2 Positive Displacement High-Pressure Pump System Piping Diagram

valve such as a ball valve for throttling the pump discharge. A flow control valve is needed to regulate the concentrate flow. A manual throttling valve, such as a needle valve, is sufficient for this application unless the flows are so low that plugging could become a problem. In that case, use a long coil of high-pressure media tubing to take the entire pressure drop through the tubing. Cut the tubing to length for the required flow.

7.2.3 See Fig. 2 for a schematic piping diagram for a positive displacement high-pressure pump test system. Valves and arrangements are similar to the centrifugal system except for the high-pressure pump piping. The back-pressure regulator on the by-pass controls pressure on the pump discharge line. Under no circumstances install throttling valves directly on a positive displacement pump discharge line. An accumulator is required to minimize pressure pulsations (<1 % of value) if a reciprocating piston-type positive displacement pump is used to feed the reverse osmosis device.

7.2.4 Operate the apparatus by drawing the feed solution from the tank and pumping it through the reverse osmosis device under pressure. Return both the concentrate stream and the permeate to the feed tank so that its volume and solute concentration remain constant. Use the heat exchanger coils in the feed tank to adjust the feed to specified operating temperature and thereafter use to remove the energy load generated by the pump. Monitor the permeate temperature very near the reverse osmosis device (within 500 mm). Pressure gages before and after the reverse osmosis device give the feed pressure and the pressure drop across the device ( $\Delta P$ ; feed pressure - concentrate pressure). Locate these gages as close as possible to the reverse osmosis device. Measure the concentrate and permeate flow rates with calibrated flowmeters from which the feed rate to the device may be determined. Remove samples of these two streams through sampling valves for conductivity/concentration measurements. Sample the feed

using the feed sample valve. Direct the return flows in the feed tank to provide adequate mixing.

**7.3 Systems**—To protect the reverse osmosis device and the high-pressure pump from abnormal operating conditions, install limit controls in the system. An electric limit control is used to shut down the high-pressure feed pump. The limit control circuit should have a manual reset relay in it so that when it shuts down it will not automatically restart. See Fig. 1 and Fig. 2 for the limit control locations. Their functions are as follows:

**7.3.1 High-Pressure Shut-Off**—Set the cutoff point in accordance with the supplier's recommendations (protects the reverse osmosis device against excessive pressure).

**7.3.2 Low-Pressure Shut-Off**—Set the cutoff point at a gage pressure of 103 kPa (15 psi) (shuts the system down when the pump water supply is interrupted and thus protects the reverse osmosis pump).

**7.3.3 High-Temperature Shut-Off**—Set the maximum temperature at 30°C (protects the reverse osmosis device against excessive temperature).

#### 7.4 Instrumentation :

**7.4.1 Pressure**—See Fig. 1 and Fig. 2 for pressure tap locations. Use a single gage equipped with a high-pressure "quick-connect" or Taylor plug gage fitting for measuring individual pressures and device pressure drop ( $\Delta P$ ). Individual gages are also satisfactory but not as reliable as a "quick-connect" test gage or a special  $\Delta P$  gage. Use pressure snubbers to prevent pulsation damage to gages, and calibrate all pressure gages.

**7.4.2 Temperature**—See Fig. 1 and Fig. 2 for temperature-measurement locations. Calibrated dial thermometers with the probe immersed in the flowing water should provide good data.

**7.4.3 Permeate Back-Pressure Considerations**—It is permissible to operate reverse osmosis devices with a back-pressure on the permeate. The maximum recommended back-pressure for these methods is 35 kPa (5 psi). This pressure is more than adequate for transferring the permeate back to the feed tank.

## TEST METHOD A—BRACKISH WATER REVERSE OSMOSIS DEVICES

### 8. Scope

8.1 This test method covers the determination of the operating characteristics of brackish water reverse osmosis devices using standard test conditions and can be used for all types of devices (tubular, spiral wound, and hollow fiber).

### 9. Summary of Test Method

9.1 The test method provides for at least three different concentrations of sodium chloride feed solution.

### 10. Reagents and Materials

**10.1 Sodium Chloride Feed Solution (5.0 g/L)**—Dissolve enough sodium chloride (NaCl) in water to make a solution containing in each litre 5.0 g of NaCl.

**10.2 Sodium Chloride Feed Solution (1.5 g/L)**—Dissolve enough sodium chloride (NaCl) in water to make a solution containing in each litre 1.5 g of NaCl.

**10.3 Sodium Chloride Feed Solution (0.5 g/L)**—Dissolve enough sodium chloride (NaCl) in water to make a solution containing in each litre 0.5 g of NaCl.

**10.4 Sodium Chloride Feed Solutions, Optional**—Other concentrations of NaCl solutions (<10 g/L) can be used.

### 11. Procedure

#### 11.1 Start-Up and Operating Procedure:

**11.1.1** If the reverse osmosis device contains sanitizing or winterizing agents, or both, flush the device in accordance with the supplier's recommendations.

**11.1.2** Make preliminary checks to make sure all fittings are tight, all components are operational, and the feed solution is at the proper concentration and temperature. Before energizing the high-pressure pump, the low-pressure switch must be off for start-up to complete the circuit past the low-pressure cutout. Energize the high-pressure pump momentarily to check proper rotation.

**11.1.3** Open the feed supply valve, the concentrate flow control valve, the pump by-pass on the positive displacement feed pump, or the centrifugal pump throttling valve. Start the booster pump and then the high-pressure pump.

**11.1.4** Bring the feed pressure to a gage pressure of  $2.75 \pm 0.07$  MPa ( $400 \pm 10$  psi). To reach 2.75 MPa, it is possible that the by-pass valve or the throttling valve (depending on pump system) and the concentrate flow control valve may need to be adjusted simultaneously. If necessary, another pressure agreed upon between the user and the supplier may be used.

**11.1.5** Set concentrate flow in accordance with the supplier's recommendation by adjusting the concentrate flow control valve. But maintain conversion within  $\pm 2\%$  of the supplier's recommendation.

**11.1.6** Recheck and adjust if necessary both the concentrate flow and feed pressure to give the selected values for flow and pressure.

**11.1.7** Check and adjust the cooling system in the feed solution to give a permeate temperature of  $25 \pm 1^\circ\text{C}$ .

**11.1.8** Once sustained operation is attained, energize the low-pressure shut-off switch.

#### 11.2 Data Recording:

**11.2.1** One hour after start-up, measure and record on a data sheet the inlet and outlet pressures of the filter and the feed, concentrate, and permeate pressures.

**11.2.2** At the same time measure and record the permeate and concentrate flows using the calibrated flowmeters or a calibrated volume container and stopwatch.

**11.2.3** Also at the same time measure and record the permeate temperature and the conductivity of the feed, permeate, and concentrate, using a conductivity meter, or determine the chloride content of the three streams in accordance with Test Methods D 512.

**11.2.4** Repeat the above measurements 2 to 3 h after start-up and hourly thereafter until three successive permeate flow rates (corrected to  $25^\circ\text{C}$ ) and salt passages agree within 5% (relative).

**11.2.5** All data shall be obtained using the specified conditions of temperature, pressure, and conversion. If any of these parameters need adjusting, allow 1 h after making adjustments before collecting data.

11.3 *Shutdown Procedure*—Shut down by adjusting the by-pass valve or throttling valve to reduce the pressure, depressing the stop buttons on the high-pressure pump motor and the booster pump motor, and shutting off the feed supply valve (shutoff valve). When high concentrations (>5000 mg/L) are used, it is best to flush the reverse osmosis device with the feed solution to remove the high salt concentration in the device. This can be done by opening the concentrate flow control valve for approximately 10 min with at least 345 kPa (50 psi) feed pressure. Allow the pressure to reach zero before disconnecting the reverse osmosis device or carrying out maintenance on the piping system. Take care to ensure that the membranes are kept wet at all times and are properly sanitized or winterized, or both (based on supplier's recommendations) for long-term storage (more than 5 days).

## 12. Calculation

12.1 Calculate the feed flow rate as follows:

$$Q_f = Q_p + Q_c$$

where:

$Q_f$  = feed flow rate,

$Q_p$  = permeate flow rate, and

$Q_c$  = concentrate flow rate.

12.1.1 The permeate flow rate ( $Q_p$ ) should be corrected to 25°C using the supplier's correction factor, or, if unavailable, a 3 % per degree correction factor can be used.

12.2 Calculate the conversion as follows:

$$\text{Conversion, \%} = (Q_p/Q_f) \times 100$$

12.3 Calculate the salt passage as follows:

$$\text{Salt passage, \%} = (K_p/K_f) \times 100$$

where:

$K_p$  = conductivity of permeate, and

$K_f$  = conductivity of feed.

NOTE 1—The use of conductivity ratios for calculating salt passage will give slightly different results as compared to using ratios from chloride ion analyses. However, for the concentration ranges involved for this method, the slight error resulting from using conductivity ratios is not considered significant.

12.4 Calculate the rejection as follows:

$$\text{Rejection, \%} = (1 - (K_p/K_f) \times 100)$$

## 13. Precision and Bias <sup>4</sup>

13.1 The precision of the test method for permeate flow rate of reverse osmosis devices is as follows:

$$S_o = 0.016X - 4.542$$

$$S_t = 0.058X - 17.411$$

where:

$S_o$  = single-operator precision, mL/min,

$S_t$  = overall precision, mL/min, and

$X$  = determined permeate flow rate of reverse osmosis device, mL/min.

13.2 The precision of the test method for salt passage of

reverse osmosis devices is as follows:

$$S_o = 0.1669 - 0.0015Y$$

$$S_t = 0.6684 + 0.026Y$$

where:

$S_o$  = single-operator precision, salt passage expressed as percent,

$S_t$  = overall precision, salt passage expressed as percent, and

$Y$  = determined salt passage of reverse osmosis device, expressed as percent.

13.3 Seven laboratories, each using a single operator, performed the testing at two concentration levels (500 mg/L and 5000 mg/L) using three different reverse osmosis devices (tubular, spiral wound, and hollow fiber).

13.4 Since the test method determines the operating characteristics of reverse osmosis devices on a relative basis, no true values can be assigned and thus the determination of the bias is not applicable.

## TEST METHOD B—SEAWATER REVERSE OSMOSIS DEVICES

### 14. Scope

14.1 This test method covers the determination of the operating characteristics of seawater reverse osmosis devices using standard test conditions and can be used for both spiral wound and hollow fiber devices.

### 15. Summary of Test Method

15.1 The test method uses a 30 000 mg/L sodium chloride feed solution. Optional sodium chloride feed solutions are also given.

### 16. Reagents and Materials

16.1 *Sodium Chloride Feed Solution* (30.0 g/L)—Dissolve enough sodium chloride (NaCl) in water to make a solution containing in each litre 30.0 g of NaCl.

16.2 *Sodium Chloride Feed Solutions, Optional*—Other concentrations of sodium chloride solutions, for example, 32.8 g/L or 35.0 g/L of NaCl can be used.

### 17. Procedure

#### 17.1 Start-up and Operating Procedure:

17.1.1 If the reverse osmosis device contains sanitizing or winterizing agents, or both, flush the device in accordance with the supplier's recommendations.

17.1.2 Perform any posttreatments (if required) on the reverse osmosis device in accordance with the supplier's recommendations.

17.1.3 Make preliminary checks to make sure all fittings are tight, all components are operational, and the feed solution is at the proper concentration and temperature. Before energizing the high-pressure pump, the low-pressure switch must be off for start-up to complete the circuit past the low-pressure cutout. Energize the high-pressure pump momentarily to check proper rotation.

17.1.4 Open the feed supply valve, the concentrate flow control valve, the pump bypass on the positive displacement

<sup>4</sup> Supporting data are available from ASTM Headquarters. Request RR:D19-1051.

feed pump, or the centrifugal pump throttling valve. Start the booster pump and then the high-pressure pump.

17.1.5 Bring the feed pressure to a gage pressure of  $5.50 \pm 0.07$  MPa ( $800 \pm 10$  psi). To reach 5.50 MPa, it is possible that the bypass valve or the throttling valve (depending on pump system) and the concentrate flow control valve may need to be adjusted simultaneously. If necessary, another pressure agreed upon between the user and the supplier may be used.

17.1.6 Set concentrate flow in accordance with the supplier's recommendation by adjusting the concentrate flow control valve. But maintain conversion within  $\pm 2\%$  of supplier's recommendation.

17.1.7 Recheck and adjust if necessary both the concentrate flow and feed pressure to give the selected values for flow and pressure.

17.1.8 Check and adjust the cooling system in the feed solution to give a permeate temperature of  $25 \pm 1^\circ\text{C}$ .

17.1.9 Once sustained operation is attained, energize the low-pressure shut-off switch.

#### 17.2 Data Recording:

17.2.1 One hour after start-up, measure and record on a data sheet the inlet and outlet pressures of the filter and the feed, concentrate, and permeate pressures.

17.2.2 At the same time, measure and record the permeate and concentrate flows using the calibrated flowmeters or a calibrated volume container and stopwatch.

17.2.3 Also at the same time, measure and record the permeate temperature and the conductivity of the feed, permeate, and concentrate, using a conductivity meter, or determine the chloride content of the three streams in accordance with Test Methods D 512.

17.2.4 Repeat the above measurements 2 to 3 h after start-up and hourly thereafter until three successive permeate flow rates (corrected to  $25^\circ\text{C}$ ) and salt passages agree within 5% (relative).

17.2.5 All data shall be obtained using the specified conditions of temperature, pressure, and conversion. If any of these parameters need adjusting, allow 1 h after making adjustments before collecting data.

#### 17.3 Shutdown Procedure:

17.3.1 Adjust the bypass valve or throttling valve to reduce the pressure.

17.3.2 Depress the stop buttons on the high-pressure pump motor and the booster pump motor.

17.3.3 Shut off the feed supply valve (shutoff valve).

17.3.4 Allow the pressure to reach zero before disconnecting the reverse osmosis device or carrying out maintenance on the piping.

17.3.5 If the test system is to be left out of service, flush with Type III reagent water to minimize corrosion.

17.3.6 Flush the reverse osmosis device based on supplier's recommendations with respect to time between test completion and flushing, water quality used for flushing and flushing procedure.

17.3.7 Take care to ensure that the membranes are kept wet at all times and are properly sanitized or winterized or both (based on supplier's recommendation) for long-term storage (more than 5 days).

## 18. Calculation

18.1 Calculate the feed flow rate as follows:

$$Q_f = Q_p + Q_c$$

where:

$Q_f$  = feed flow rate,

$Q_p$  = permeate flow rate, and

$Q_c$  = concentrate flow rate.

18.1.1 The permeate flow rate ( $Q_p$ ) should be corrected to  $25^\circ\text{C}$  using the supplier's correction factor, or, if unavailable, a 3% per degree correction factor can be used.

18.2 Calculate the conversion as follows:

$$\text{Conversion, \%} = Q_p/Q_f \times 100$$

18.3 Calculate the salt passage as follows:

$$\text{Salt passage, \%} = C_p/C_f \times 100$$

where:

$C_p$  = concentration of salt in permeate, and

$C_f$  = concentration of salt in feed.

NOTE 2—Salt concentration can be calculated from chloride ion analyses or conductivity but if conductivity is used, it must first be converted to concentration from calibration curves because conductivity is not a linear function of concentration over the large range involved in this method.

18.4 Calculate the rejection as follows:

$$\text{Rejection, \%} = (1 - C_p/C_f) \times 100$$

## 19. Precision and Bias <sup>5</sup>

19.1 The precision of the test method for permeate flow rate of reverse osmosis devices is as follows:

$$S_o = 0.017X + 2.750$$

$$S_T = 0.068X + 2.000$$

where:

$S_o$  = single-operator precision, mL/min,

$S_T$  = overall precision, mL/min, and

$X$  = determined permeate flow rate of reverse osmosis device, mL/min (range 496 to 594 mL/min for hollow fiber and 1833 to 2190 mL/min for spiral devices).

19.2 The precision of the test method for salt passage of reverse osmosis devices is as follows:

$$S_o = 0.0208Y + 0.0120$$

$$S_T = 0.1786Y - 0.0700$$

where:

$S_o$  = single-operator precision, salt passage expressed as percent,

$S_T$  = overall precision, salt passage expressed as percent, and

$Y$  = determined salt passage of reverse osmosis device, expressed as percent (range 0.76 to 0.99% for hollow fiber and 3.48 to 5.59% for spiral devices).

19.3 Four laboratories, each using two operators, performed the testing using two different reverse osmosis devices (spiral

<sup>5</sup> Supporting data are available from ASTM Headquarters. Request RR:D19-1085.

wound and hollow fiber).

19.4 Since the test method determines the operating characteristics of reverse osmosis devices on a relative basis,

no true values can be assigned and thus the determination of the bias is not applicable.

*The American Society for Testing and Materials takes no position respecting the validity of any patent rights asserted in connection with any item mentioned in this standard. Users of this standard are expressly advised that determination of the validity of any such patent rights, and the risk of infringement of such rights, are entirely their own responsibility.*

*This standard is subject to revision at any time by the responsible technical committee and must be reviewed every five years and if not revised, either reapproved or withdrawn. Your comments are invited either for revision of this standard or for additional standards and should be addressed to ASTM Headquarters. Your comments will receive careful consideration at a meeting of the responsible technical committee, which you may attend. If you feel that your comments have not received a fair hearing you should make your views known to the ASTM Committee on Standards, 100 Barr Harbor Drive, West Conshohocken, PA 19428.*