



Standard Test Methods for Total and Dissolved Carbon Dioxide in Water¹

This standard is issued under the fixed designation D 513; the number immediately following the designation indicates the year of original adoption or, in the case of revision, the year of last revision. A number in parentheses indicates the year of last approval. A superscript epsilon (ϵ) indicates an editorial change since the last revision or reapproval.

1. Scope

1.1 These test methods provide for the measurement of total or dissolved carbon dioxide present as carbon dioxide (CO₂), carbonic acid, bicarbonate ion, and carbonate ion in water:

	Range	Sections
Test Method A (Gas Sensing Electrode)	2 to 800 mg/L	8 to 15
Test Method B (CO ₂ Evolution, Coulometric Titration)	5 to 800 mg/L	16 to 24

1.2 Carbon dioxide may also be detected from carbonates present in particulates in samples.

1.3 Test Method A is applicable to various natural waters and brines.

1.4 Test Method B is applicable to natural waters, brines, and various industrial waters as delineated in 16.4.

1.5 It is the user's responsibility to ensure the validity of these test methods on waters of untested matrices.

1.6 Several test methods were discontinued from this standard in 1988. Refer to Appendix X1 for historical information.

1.7 *This standard does not purport to address all of the safety concerns, if any, associated with its use. It is the responsibility of the user of this standard to establish appropriate safety and health practices and determine the applicability of regulatory limitations prior to use.*

2. Referenced Documents

2.1 ASTM Standards:

D 1066 Practice for Sampling Steam²

D 1129 Terminology Relating to Water²

D 1192 Guide for Equipment for Sampling Water and Steam in Closed Conduits²

D 1193 Specification for Reagent Water²

D 1293 Test Methods for pH of Water²

D 2777 Practice for Determination of Precision and Bias of Applicable Test Methods of Committee D19 on Water²

D 3370 Practices for Sampling Water from Closed Conduits²

¹ These test methods are under the jurisdiction of ASTM Committee D19 on Water and are the direct responsibility of Subcommittee D19.05 on Inorganic Constituents in Water.

Current edition approved July 10, 2002. Published August 2002. Originally published as D 513 – 38. Last previous edition D 513 – 92 (1996).

² *Annual Book of ASTM Standards*, Vol 11.01.

D 5847 Practice for Writing Quality Control Specifications for Standard Test Methods for Water Analysis³

E 200 Practice for Preparation, Standardization, and Storage of Standard and Reagent Solutions for Chemical Analysis⁴

3. Terminology

3.1 *Definitions*—For definitions of terms used in these test methods, refer to Terminology D 1129.

4. Significance and Use

4.1 Carbon dioxide is a major respiration product of plants and animals and a decomposition product of organic matter and certain minerals. The atmosphere averages about 0.04 vol % of CO₂. Surface waters generally contain less than 10 mg/L, except at local points of abnormal organic or mineral decomposition; however, underground water, particularly deep waters, may contain several hundred mg/L.

4.2 When dissolved in water, CO₂ contributes significantly to corrosion of water-handling systems. This is particularly troublesome in steam condensate systems. Loss of CO₂ from an aqueous system can disturb the carbonate equilibrium and result in calcite encrustation of confining surfaces. Scaling of water heaters is a good example. Because of the delicate balance between corrosion and encrustation tendencies, much care must be given to control of CO₂ and related species in water systems. Recarbonation of municipal supplies during final stages of softening and amine neutralization of steam condensate are applied for these purposes.

5. Purity of Reagents

5.1 Reagent grade chemicals shall be used in all tests. Unless otherwise indicated, it is intended that all reagents shall conform to the specifications of the Committee on Analytical Reagents of the American Chemical Society.⁵ Other grades

³ *Annual Book of ASTM Standards*, Vol 11.02.

⁴ *Annual Book of ASTM Standards*, Vol 15.05.

⁵ *Reagent Chemicals, American Chemical Society Specifications*, American Chemical Society, Washington, DC. For suggestions on the testing of reagents not listed by the American Chemical Society, see *Analar Standards for Laboratory Chemicals*, BDH Ltd., Poole, Dorset, U.K., and the *United States Pharmacopoeia and National Formulary*, U.S. Pharmacopoeial Convention, Inc. (USPC), Rockville, MD.

may be used, provided it is first ascertained that the reagent is of sufficiently high purity to permit its use without lessening the accuracy of the determination.

5.2 Unless otherwise indicated, references to water shall be understood to mean water conforming to Type I of Specification D 1193. Additionally, for those test methods requiring water free of CO₂, refer to 8.2 of Practice E 200.

6. Precautions

6.1 **Warning**—Carbon dioxide is easily lost from solution during transit and storage of samples. It is also possible for total CO₂ concentration to increase after sampling due to solution of finely divided calcium carbonate as a result of temperature or pressure changes.

7. Sampling

7.1 Collect the sample in accordance with Practices D 1066 and D 3370 and Specification D 1192, as applicable.

7.2 Filter samples when they are collected if particulates are present that may contain carbonates if dissolved species only are to be determined. When aliquots of sample are taken from sample bottles containing particulates, the bottle must be shaken or otherwise homogenized to ensure a representative sample is taken. When particulates form in samples due to changes in temperature, pH, etc., after the sample has been collected, these particulates must be included in tests of the sample. Care must be used to avoid loss of CO₂ during any homogenization or filtration of samples. Do not filter samples unless it is required to remove potentially interfering particulates.

7.3 Use a hard, glass, chemically resistant bottle for collecting the sample.

7.4 Fill the sample bottle completely, with no air space remaining beneath the cap, and store the sample at a temperature below that at which it was collected until the determination is made.

TEST METHOD A—GAS SENSING ELECTRODE TEST METHOD

8. Scope

8.1 This test method determines total or dissolved carbon dioxide (9.2) present as CO₂, carbonic acid, bicarbonate ion, and carbonate ion in water, within the interference constraints specified.

8.2 Samples containing 2 to 800 mg/L total CO₂ can be analyzed by this test method. The concentration range may be extended by dilution of an appropriate aliquot.

8.3 Samples should be analyzed immediately. If this is not possible, preserve by making them slightly alkaline (pH between 8 and 9) using carbonate-free NaOH solution and store them in a tightly capped vessel. The latter step prevents absorption of CO₂ from the air.

8.4 The precision and bias were obtained on reagent water and a water matrix of choice that included natural waters and brines. It is the responsibility of the analyst to determine the acceptability of this test method for the water being analyzed.

9. Summary of Test Method

9.1 Carbon dioxide is liberated by acidification of the sample to pH 5.0. The carbon dioxide electrode uses a gas-permeable membrane to separate the sample solution from the electrode internal solution. Dissolved carbon dioxide in the sample solution diffuses through the membrane until an equilibrium is reached between the partial pressure of CO₂ in the sample solution and the CO₂ in the internal filling solution. In any given sample, the partial pressure of CO₂ will be proportional to the concentration of CO₂. The diffusion of CO₂ across the membrane affects the concentration of hydrogen ions in the internal filling solution:

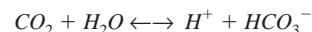

The hydrogen ion concentration of the internal solution is measured by the pH electrode located behind the membrane. Since the hydrogen ion concentration is directly related to CO₂ concentration, the electrode response is Nernstian.

9.2 Samples are treated prior to measurement with a buffer solution that sets the pH between 4.8 and 5.2. At this pH, interferences are minimized and the various ionic forms are converted to CO₂ (see Section 10).

10. Interferences

10.1 Volatile weak acids are potential positive electrode interferences. Concentrations of these interfering species that cause a 10 % error at 44 mg/L CO₂ or 100 mg/L (as CaCO₃) and at pH 4 and 5, are listed below:

Interferences, mg/L	pH 5	pH 4
H ₂ S	10	7
NO ₂ ⁻ (NO ₂)	161	24
HSO ₃ ⁻ (SO ₂)	320 (as SO ₂)	48 (as SO ₂)
HOAc (acetic acid)	372	216
HCOOH (formic acid)	1841	345

10.2 Samples containing sulfide can be treated with dilute solutions of potassium dichromate (or the like), since sulfur is not an interference for this test method. However, it is possible that some organic material could be oxidized to CO₂ by this treatment, resulting in falsely high results. The suitability of the test method for samples containing sulfide should be determined individually.

10.3 Water vapor is a potential electrode interference. Water can move across the membrane as water vapor, changing the concentration of the internal filling solution under the membrane. Such changes will be seen as electrode drift. Water vapor transport is not a problem if (1) the total concentration of dissolved species in solution (Note 1) is approximately equal to that of the internal filling solution, and (2) electrode and sample temperatures are the same.

NOTE 1—The osmotic strength of a solution is related to the total concentration of dissolved species in the solution. For example, the osmotic strength of a solution containing 0.1 M hydrochloric acid, 0.1 M acetic acid, and 0.1 M sucrose is determined as follows: Hydrochloric acid dissociates to give 0.1 M hydrogen ion and 0.1 M chloride ion. The acetic acid, because of the concentration of free hydrogen ion, is essentially undissociated; thus giving 0.1 M of species. Likewise, the concentration of sucrose species is 0.1 M. Therefore, the total osmotic strength is 0.4 osmolar.

10.4 Addition of carbon dioxide buffer (12.1) to samples of low osmotic strength automatically adjusts them to the correct

level. Samples with osmotic strength greater than approximately 1 *M* should be diluted before measurement to avoid drifting associated with water vapor transport. Dilution should not reduce the carbon dioxide level below 2.5 mg/L. Samples with osmotic strengths above 1 *M* that cannot be diluted can be measured by adjusting the osmotic strength of the internal filling solution. To adjust the total concentration of dissolved species in the internal filling solution, add 0.425 g of reagent-grade NaNO₃ to 10 mL of internal filling solution.

11. Apparatus

11.1 *pH Meter*, with expanded mV scale, or a selective ion meter.

11.2 *CO₂ Gas-Sensing Electrode*.⁶

11.3 *Mixer*, magnetic with TFE-fluorocarbon-coated stirring bar or equivalent.

12. Reagents

12.1 *Buffer Solution*—Dissolve 294 g of sodium citrate in approximately 700 mL of water in a 1-L volumetric flask. Acidify the solution to pH 4.5 with concentrated HCl (approximately 90 mL) and dilute to the mark with water.

12.2 *Sodium Bicarbonate Solution, Standard (0.1 M)*—Dissolve 8.40 g of sodium bicarbonate in water and dilute to 1 L.

12.3 *Sodium Bicarbonate Solution, Standard (0.01 M)*—Dilute 10.0 mL of sodium bicarbonate standard solution (0.1 *M*) to 100 mL.

13. Calibration and Standardization

13.1 Assemble and check the electrode in accordance with the manufacturer's instructions.

13.2 Dilute 10 mL of the buffer solution to 100 mL with water using a volumetric flask. Transfer the contents of the flask to a 150-mL beaker and add a stirring bar. Immerse the electrode in the solution. Stir at a slow rate using the magnetic stirrer.

13.3 Using a volumetric pipette, add 0.5 mL of the 0.01 *M* NaHCO₃ standard solution and mix slowly. Allow the potential reading to stabilize (approximately 10 min) and record the potential (corresponds to 2.2 mg/L CO₂ or 5.0 mg/L (as CaCO₃)).

13.4 Using a volumetric pipette, add 0.5 mL of the 0.01 *M* NaHCO₃ standard solution and mix slowly. Allow the potential reading to stabilize (approximately 5 min) and record the potential (corresponds to 4.4 mg/L CO₂ or 10.0 mg/L (as CaCO₃)).

13.5 Using a volumetric pipette, add 0.9 mL of the 0.1 *M* NaHCO₃ standard solution and mix slowly. Allow the potential reading to stabilize (approximately 2 min) and record the potential (corresponds to 43.2 mg/L CO₂ or 98.1 mg/L (as CaCO₃)).

13.6 Using a volumetric pipette, add 10 mL of the 0.1 *M* NaHCO₃ standard solution and mix slowly. Allow the potential reading to stabilize (approximately 2 min) and record the potential (corresponds to 433 mg/L CO₂ or 983 mg/L (as CaCO₃)).

13.7 Plot potential values (on the linear scale) versus concentration (on the logarithmic scale) on semilogarithmic graph paper to obtain a calibration curve. The curve may be extended down to 2 mg/L and up to 800 mg/L CO₂.

14. Procedure

14.1 Bring samples to the same temperature as the electrode and standards.

14.2 Place a known volume, *V_s*, (100 mL is convenient) of sample in 150-mL beaker and stir slowly. Immerse the electrode in the solution.

14.3 Add 1 mL of buffer, *V_b*, for each 10 mL of sample. Allow the potential reading to stabilize and record the value. Read the concentration measured, *C_m*, directly from the calibration curve.

14.4 Determine the sample concentration, *C_s*, as follows:

$$C_s = C_m \frac{V_s + V_b}{V_s}$$

15. Precision and Bias⁷

15.1 *Precision*—The overall and single operator precision of this test method, within its designated range, varies with the quantity tested as shown in Fig. 1 for reagent water and Fig. 2 for selected water matrices. These matrices included natural waters and brines.

15.2 *Bias*—Recoveries of known amounts of total CO₂ from reagent water and selected water matrices were as shown in Table 1.

15.3 The information in 15.1 and 15.2 is derived from round-robin testing in which eight laboratories, including twelve independent operators, participated. Of twelve data sets ranked as described in Practice D 2777, four were rejected in the case of reagent water and three were rejected in the case of selected water matrices. Four outlier data points were also rejected. Four sample levels were run on three days, and blanks were obtained for the waters used.

15.4 Precision and bias for this test method conforms to Practice D 2777, which was in place at the time of collaborative testing. Under the allowances made in 1.4 of Practice D 2777, these precision and bias data do meet existing requirements for interlaboratory studies of Committee D19 test methods.

TEST METHOD B—CO₂ EVOLUTION, COULOMETRIC TITRATION TEST METHOD

16. Scope

16.1 This test method determines total or dissolved carbon dioxide present as carbon dioxide, carbonic acid, bicarbonate ion, and carbonate ion in water within the interference constraints specified.

⁶ The sole source of supply of the apparatus known to the committee at this time is Orion Research Inc., 529 Main St., Boston, MA 02129. If you are aware of alternative suppliers, please provide this information to ASTM Headquarters. Your comments will receive careful consideration at a meeting of the responsible technical committee, which you may attend.

⁷ Supporting data for this test method are available from ASTM Headquarters. Request RR:D19-1069.

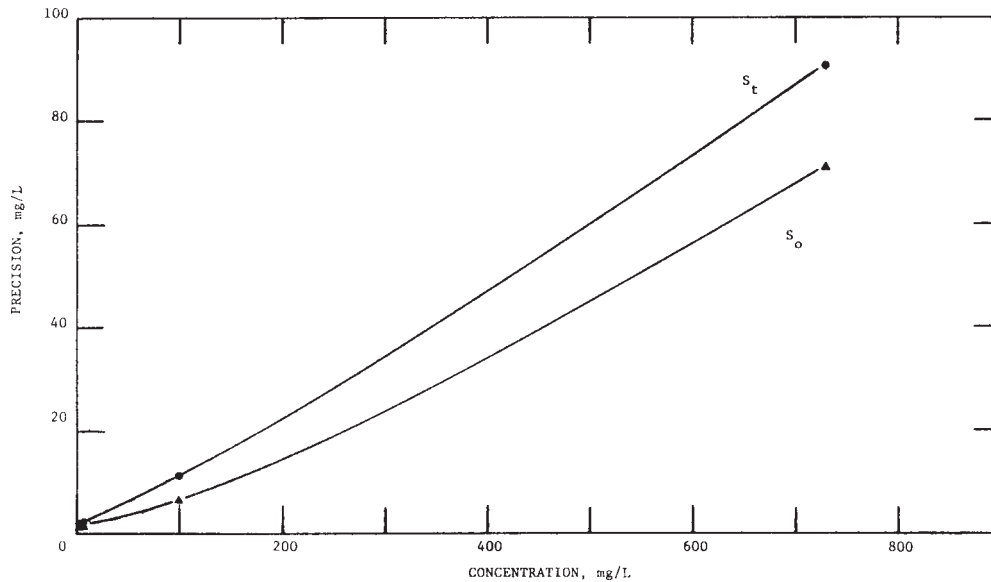

FIG. 1 Interlaboratory Precision for Total CO₂ Found in Reagent Water—Test Method A

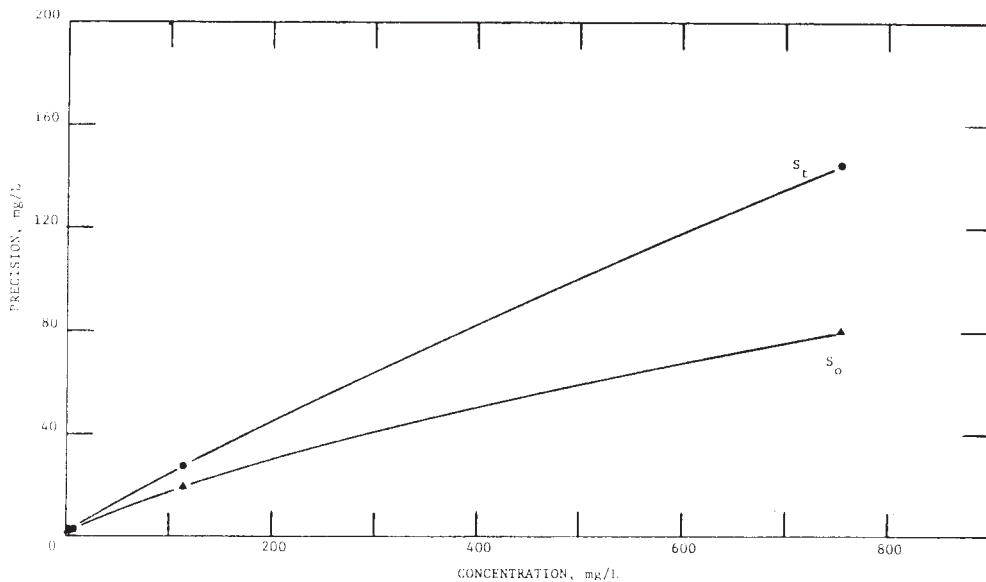

FIG. 2 Interlaboratory Precision for Total CO₂ Found in Selected Water Matrices—Test Method A

TABLE 1 Bias—Test Method A

Amount Added, mg/L	Amount Found, mg/L	± %Bias	Statistically Significant (91 % Confidence Level)
Reagent water			
2.1	2.7	+ 28.6	no
5.1	6.9	+ 35.3	yes
101	100	-1.0	no
803	730	-9.1	yes
Water matrices			
2.1	3.0	+ 42.8	no
5.1	7.1	+ 39.2	yes
101	114	+ 12.9	no
803	754	-6.1	no

16.2 Carbon dioxide will also be detected from carbonates present in particulates in samples.

16.3 Samples containing between 5 and 800 mg/L total CO₂ can be analyzed by this test method. The concentration range may be extended upward by use of smaller samples or dilution of an appropriate aliquot. The range may be extended lower by use of larger samples.

16.4 The precision and bias information reported in this test method was obtained in collaborative testing that included waters of the following types: distilled, deionized, potable, natural, brine, industrial waste, and waters derived from oil shale retorting. Since the precision and bias information reported may not apply to waters of all matrices, it is the user's responsibility to ensure the validity of the test method on samples of other matrices.

17. Summary of Test Method

17.1 Carbon dioxide is liberated by acidifying and heating the samples. The liberated CO₂ is swept through a scrubber by

carbon dioxide-free air into an absorption cell where it is automatically coulometrically titrated. Concentrations of the several carbonate species are determined from the pH and total CO₂ values.

18. Interferences

18.1 Any volatile acid or base not removed by the scrubbing solution will interfere with the test. Potentially interfering gases that the scrubber removes include: hydrogen sulfide (H₂S), chlorine (Cl₂), bromine (Br₂), hydrogen chloride (HCl), hydrogen bromide (HBr), hydrogen iodide (HI), hydrogen fluoride (HF), sulfur dioxide (SO₂), and sulfur trioxide (SO₃).

18.2 If a significant precipitate forms in the scrubber solution during an analysis, the scrubber solution should be replaced and the analysis repeated.

18.3 If the level of potentially interfering materials is such that the scrubber capacity is exhausted rapidly, an additional higher capacity scrubber may be added as directed under 19.3. When two scrubbers are used, the scrubber capacity is considered to be exhausted when a precipitate begins forming in the final scrubber.

18.4 When analyzing samples that may evolve acid gases other than those listed, previously spiked samples should be analyzed to confirm that the scrubbers used are effective and, scrubbers should be modified if necessary.

19. Apparatus

19.1 *Carbon Dioxide Coulometer* to automatically titrate evolved carbon dioxide.⁸

19.2 *Carbon Dioxide Evolution Apparatus*, consisting of an air pump, air purification scrubber, acid dispenser, sample reaction chamber, and scrubber. The arrangement of the apparatus is shown in Fig. 3.

19.3 *High Capacity Scrubber*, if needed, may be assembled as illustrated in Fig. 4. It should be installed so the gas flows from the sample air outlet through the scrubber into the regular scrubber. The size may be increased over that specified, but doing so may lengthen the analysis time.

19.4 *pH Meter*, conforming to the requirements given in Test Methods D 1293.

20. Reagents

20.1 *Coulometer Cell Reagents*—Cell solutions to absorb CO₂ from the gas stream and convert it to a titratable acid and permit 100 % efficient coulometric titration.

20.2 *Perchloric Acid Solution* (approximately 1 + 5)—Add 170 mL of concentrated HClO₄ (sp gr 1.67) to 500 mL of water, mix, and dilute to 1 L with water.

20.3 *Potassium Hydroxide Solution* (65 g/100 mL)—Dissolve 65 g of KOH in water and dilute to 100 mL with water.

20.4 *Scrubber Solution*—Add 2 mL of concentrated HClO₄ (sp gr 1.67) and 5 g of silver perchlorate (AgClO₄) to

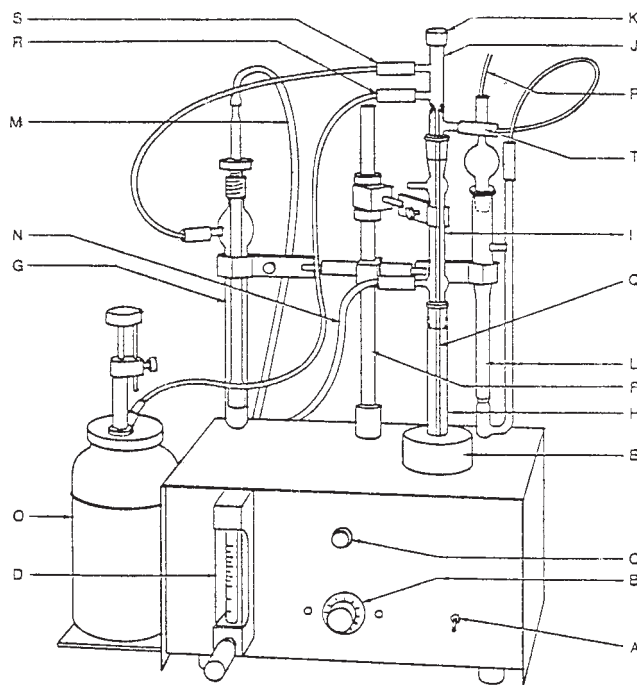

- | | |
|------------------------|---------------------------------|
| A Main power | K Septum |
| B Heater control | L Sample scrubber |
| C Heat indicator light | M Analysis air line |
| D Flow meter | N Condenser air line |
| E Heater and shield | O Acid dispenser |
| F Main support | P Scrubber outlet to coulometer |
| G Air scrubber | Q Sample purge tube |
| H Sample tube | R Acid inlet |
| I Condenser | S Purified air inlet |
| J Adaptor tube | T Sample air outlet |

FIG. 3 Carbonate Carbon (CO₂) Apparatus—Test Method B

100 mL of water. When adding scrubber solution to the scrubbers, and 0.1 mL of 30 % hydrogen peroxide (H₂O₂) to the scrubber per mL of scrubber solution used in the scrubber. As an alternative scrubber solution, use 2 mL of concentrated sulfuric acid (H₂SO₄) per 100 mL of water saturated with silver sulfate (Ag₂SO₄) and add 30 % H₂O₂ as for the AgClO₄ scrubber solution.

21. Calibration and Standardization

21.1 Calibration is not required; however, standards should be analyzed before analyzing samples and periodically to confirm proper operation of the instrument. If the recovery of a standard is unacceptable, the cause of the poor result should be determined and corrected. Generally low results are due to leaks, and high results are due to contamination of reagents or an exhausted scrubbers.

22. Procedure

22.1 Blank Determination:

22.1.1 Set up the CO₂ coulometer as directed by the instrument manufacturer.

22.1.2 Acidify 100 mL of water to a pH between 2 and 3 with HClO₄ (1 + 5) and boil vigorously for at least 15 min to remove dissolved CO₂.

⁸ The sole source of supply of the apparatus known to the committee at this time is Coulometrics, Inc., a subsidiary of UIC Inc., P.O. Box 863, Joliet, IL 60434. If you are aware of alternative suppliers, please provide this information to ASTM Headquarters. Your comments will receive careful consideration at a meeting of the responsible technical committee, which you may attend.

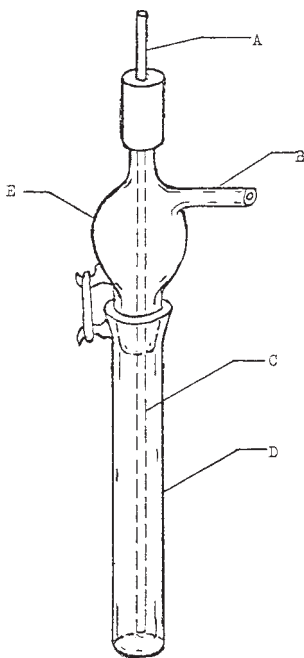

A Inlet, from sample air outlet
 B Outlet, to standard scrubber
 C Tube, extends into scrubber solution
 D Body, glass with $\frac{1}{2}$ standard-taper joint, total length 125 mm, used with up to 12-mL scrubber solution
 E Adaptor, glass

FIG. 4 High-Capacity Scrubber—Test Method B

22.1.3 Inject 5.00 mL of selected sample size (see 22.2) of the freshly boiled water into the apparatus using a calibrated syringe. Set the coulometer display to 0, pump 2 mL of HClO_4 (1 + 5) into the reaction tube, and position the reaction tube over the heater. After 5 min record the coulometer displays as B.

22.1.4 Make a blank determination before each series of CO_2 determinations.

22.1.5 Empty the reaction tube following completion of an analysis if the remaining volume is insufficient for the next sample plus acid. The maximum liquid volume of the sample tube is 12 mL. When the sample tube is replaced, CO_2 from air that entered the apparatus must be swept out by the gas stream before beginning the next analysis. Sixty seconds is normally sufficient for this. To eliminate the necessity of removing the sample tube and the subsequent purge time, a stopcock may be attached to the sample tube to permit draining following an analysis.

22.2 Carbon Dioxide Determination:

22.2.1 For samples with less than 800 mg/L of CO_2 , use the procedure described in 22.1.3 for blank determinations on a 5.00-mL untreated portion of the sample. Record the coulometer readout as A.

22.2.2 If the CO_2 content of the sample exceeds 800 mg/L, use a proportionately smaller sample and adjust the calculations accordingly. Do not reduce sample volumes so much that representative samples cannot be obtained or sample volumes cannot be measured with sufficient accuracy. Alternatively, the sample may be diluted using CO_2 -free water. For samples

containing less than 100 mg/L, accuracy may be increased by use of a larger sample size if a larger sample tube is used.

22.2.3 If the volume of the sample tube or scrubbers is increased, the analysis time may have to be lengthened. At the end of an analysis the titration should be complete and the coulometer display stable. If the titration is not complete, the analysis time must be lengthened for both blanks and samples.

22.2.4 If desired, samples may be pipetted into acid free reaction tubes positioned on the apparatus to begin the analysis. In this case, sufficient time (generally 60 s) must be allowed for CO_2 from air that entered the apparatus to be swept from the apparatus before acid is added and the analysis begun.

NOTE 2—For some samples, a significant amount of CO_2 may be removed during the purge of the apparatus. This can be determined by comparing the amount of CO_2 removed during the purge of a blank and the purge of the sample.

22.2.5 If 2 mL of HClO_4 (1 + 5) is not sufficient to acidify the samples to pH 3 or less, more acid may be used or more concentrated HClO_4 used. Sulfuric acid may be substituted for HClO_4 . When samples include sediments or other particulate matter, wetting and emulsifying agents may be added to acid to ensure a more rapid reaction between the solids and the acid.

22.3 Determine the pH of the original sample in accordance with Test Methods D 1293.

NOTE 3—If the temperature of the sample at the time of the test is different from its temperature at the time of collection, different CO_2 - HCO_3 - CO_3 equilibrium and pH will result. This may be partially overcome by adjusting the sample to the collection temperature and shaking it thoroughly before opening it for CO_2 and pH tests. It is best to avoid the problem by measuring pH at the time of sample collection, and sealing the sample to prevent loss or gain of CO_2 .

23. Calculation

23.1 Calculate the concentration of the total CO_2 using 23.1.1 or 23.1.2 and 23.1.3 as appropriate for the coulometer display units and the sample volume used.

23.1.1 The CO_2 coulometer set to display micrograms of carbon:

$$\text{Total CO}_2, \text{ mg/L} = 0.7329 (A - B)$$

where:

- A = carbon from sample, μg , and
- B = carbon from blank determination, μg .

23.1.2 The CO_2 coulometer set to display micrograms of carbon dioxide:

$$\text{Total CO}_2 \text{ mg/L} = 0.200 (A - B)$$

where:

- A = carbon dioxide from sample, μg , and
- B = carbon dioxide from blank determination, μg .

23.1.3 If the sample size used is not 5.00 mL, adjust the calculation accordingly by multiplying the value calculated in 23.1.1 or 23.1.2 by 5 mL sample volume.

24. Precision and Bias ⁷

24.1 *Precision*—The single operator and overall precision of this test method within its designated range varies with the quantity being tested in accordance with Fig. 5.

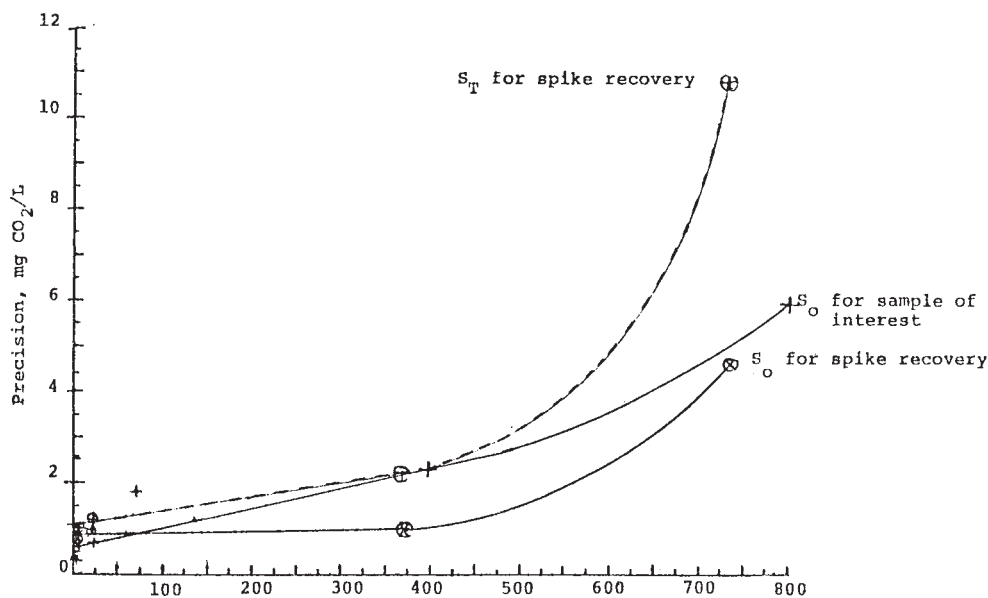

FIG. 5 Interlaboratory Precision for CO₂ Found in Water by Acid Evolution and Coulometric Titration—Test Method B

24.2 *Bias*—Recoveries of known amounts of CO₂ in a series of spiked samples of choice were as shown in Table 2.

24.3 The precision and bias data were derived from results of the cooperative tests on samples prepared by laboratories spiking a matrix of choice with solutions of NaHCO₃. Eight laboratories participated. Samples of interest chosen by participating laboratories included distilled water, deionized water, potable water, natural waters, brine, industrial waters, and waters derived from oil shale retorting. The procedure may not apply to all matrices. It is the user’s responsibility to ensure the validity of this test method on other sample matrices and to determine the effect on the precision and bias when other than 5.00-mL sample volumes are used.

24.4 Precision and bias for this test method conforms to Practice D 2777, which was in place at the time of collaborative testing. Under the allowances made in 1.4 of Practice D 2777, these precision and bias data do meet existing requirements for interlaboratory studies of Committee D19 test methods.

TABLE 2 Bias—Test Method B

Amount Added, mg/L	Amount Found, mg/L	± % Bias	Statistically Significant
7.8	8.09	+ 3.72	No
22.1	22.29	+ 0.86	No
372.1	369.83	- 0.64	Yes
736.0	730.87	- 0.70	Yes

25. Quality Control (QC)

25.1 The following quality control information is recommended for the determination of carbon dioxide in water.

25.2 The instrument shall be calibrated according to Sections 13 or 21. In addition to the initial calibration blank, a calibration blank shall be analyzed at the end of the batch run to ensure contamination was not a problem during the batch analysis.

25.3 An instrument check standard shall be analyzed at a minimum frequency of 10 % throughout the batch analysis. The value of the instrument check standard should fall between 80 % and 120 % of the true value.

25.4 A Laboratory Control Sample shall be analyzed with each batch of samples at a minimum frequency of 10 %.

25.5 If the QC for the sample batch is not within the established control limits, reanalyze the samples or qualify the results with the appropriate flags, or both (see Practice D 5847).

25.6 Blind control samples should be submitted by an outside agency in order to determine the laboratory performance capabilities.

26. Keywords

26.1 carbon dioxide (CO₂); coulometry; gas-sensing electrode

APPENDIX
(Nonmandatory Information)
X1. RATIONALE FOR DISCONTINUATION OF TEST METHODS

X1.1 The test methods briefly described in X1.1.1 through X1.1.5 were discontinued in 1988. They are published in their entirety in the 1987 *Annual Book of ASTM Standards*, Vol 11.01.

X1.1.1 *Precise CO₂ Evolution Test Method*—Carbon dioxide is liberated by acidifying and heating the sample in a closed system, which includes a condenser, a gas scrubber, a CO₂ absorber, an expansion bladder, and a gas-circulating pump. The liberated CO₂ is combined with barium hydroxide in an absorber, and the excess hydroxide is titrated with standard acid. Concentrations of the several carbonate species are determined from the pH and total CO₂ values.

X1.1.2 *Abridged CO₂ Evolution Test Method*—Carbon dioxide and bicarbonate ion are fixed with sodium hydroxide and precipitated as strontium carbonate. The solution is then neutralized, the CO₂ is removed by aeration in the presence of excess acid, and the quantity removed is determined by back-titration of the acid.

X1.1.3 *Bicarbonate Titration Test Method*—Carbon dioxide concentration is determined from measured values of pH and bicarbonate ion.

X1.1.4 *Differential Titration Test Method*—The water sample is titrated to 8.5 and 5.0 pH using standard alkali and acid as appropriate. It then is acidified, boiled to remove CO₂, retitrated to the same two pH points, and the total CO₂ content is calculated.

X1.1.5 *Direct Titration of Free CO₂*—Free CO₂ is reacted with sodium hydroxide to form sodium bicarbonate. The end point of the reaction is detected electrometrically or by means of a pH color indicator.

X1.2 The test methods in X1.1.1 through X1.1.5 were discontinued because there were insufficient laboratories interested in participating in the collaborative studies needed to provide the precision and bias data required by Practice D 2777.

ASTM International takes no position respecting the validity of any patent rights asserted in connection with any item mentioned in this standard. Users of this standard are expressly advised that determination of the validity of any such patent rights, and the risk of infringement of such rights, are entirely their own responsibility.

This standard is subject to revision at any time by the responsible technical committee and must be reviewed every five years and if not revised, either reapproved or withdrawn. Your comments are invited either for revision of this standard or for additional standards and should be addressed to ASTM International Headquarters. Your comments will receive careful consideration at a meeting of the responsible technical committee, which you may attend. If you feel that your comments have not received a fair hearing you should make your views known to the ASTM Committee on Standards, at the address shown below.

This standard is copyrighted by ASTM International, 100 Barr Harbor Drive, PO Box C700, West Conshohocken, PA 19428-2959, United States. Individual reprints (single or multiple copies) of this standard may be obtained by contacting ASTM at the above address or at 610-832-9585 (phone), 610-832-9555 (fax), or service@astm.org (e-mail); or through the ASTM website (www.astm.org).