



Designation: **D 5256—92 (Reapproved 1996) 5256 – 00**

## **Standard Test Method for Relative Efficacy of Dynamic Solvent Systems for Dissolving Water-Formed Deposits<sup>1</sup>**

This standard is issued under the fixed designation D 5256; the number immediately following the designation indicates the year of original adoption or, in the case of revision, the year of last revision. A number in parentheses indicates the year of last reapproval. A superscript epsilon ( $\epsilon$ ) indicates an editorial change since the last revision or reapproval.

### **1. Scope**

1.1 This test method covers the determination of the relative efficacy of dynamic solvent systems for dissolving water-formed deposits that have been ~~either removed from the underlying material or synthetically prepared~~, or deposits attached to the underlying material.

1.2 The nature of this test method is such that statements of precision and bias as determined by round robin tests could mislead users of this test method (see Sections 11 and 12). Therefore, no precision and bias statements are made.

1.3 The values stated in SI units are to be regarded as the standard.

1.4 *This standard does not purport to address all of the safety concerns, if any, associated with its use. It is the responsibility of the user of this standard to establish appropriate safety and health practices and determine the applicability of regulatory limitations prior to use.*

### **2. Referenced Documents**

2.1 *ASTM Standards:*

D 887 Practice for Sampling Water-Formed Deposits <sup>2</sup>

---

<sup>1</sup> This test method is under the jurisdiction of ASTM Committee D-19 on Water and is the direct responsibility of Subcommittee D19.03 on Sampling of Water and Water-Formed Deposits, Surveillance of Water, and Flow Measurement of Water.

Current edition approved June 15, 1992; 10, 2000. Published October 1992; July 2000. Originally published as D 5256-92. Last previous edition D 5256-92 (1996)



- D 1129 Terminology Relating to Water<sup>3</sup>
- D 1193 Specification for Reagent Water<sup>3</sup>
- D 2331 Practices for Preparation and Preliminary Testing of Water-Formed Deposits<sup>2</sup>
- D 2777 Practice for Determination of Precision and Bias of Applicable Methods of Committee D-19 on Water<sup>3</sup>
- D 2790 Methods for Analysis of Solvent Systems Used for Removal of Water-Formed Deposits<sup>4</sup>
- D 3263 Test Methods for Corrosivity of Solvent Systems for Removing Water-Formed Deposits<sup>2</sup>
- D 3483 Test Methods for Accumulated Deposition in a Steam Generator Tube<sup>2</sup>
- D 4743 Test Methods for Efficacy of Solvent Systems for Dissolving Water-Formed Deposits<sup>2</sup>

### 3. Terminology

#### 3.1 Definitions:

3.1.1 *water-formed deposits*—any accumulation of insoluble material derived from water or formed by the reaction of water upon the surface in contact with the water. See 3.1.1.1.

3.1.1.1 *Discussion*—Deposits formed from or by water in all its phases may be further classified as scale, sludge, corrosion products, or biological deposits. The overall composition of a deposit or some part of a deposit may be determined by chemical or spectrographic analysis; the constituents actually present as chemical substances may be identified by microscope or x-ray diffraction studies. Organisms may be identified by microscopical or biological methods.

3.1.2 For definitions of other terms used in this test method, refer to Terminology D 1129 and Test Method D 4743.

#### 3.2 Definitions of Terms Specific to This Standard:

3.2.1 *dynamic solvent system*—any closed loop system in which the solvent is in motion across the deposit surface.

3.2.2 *single and multiple solvent systems*—a single solvent system is a one-solution treatment. A multiple solvent system is a treatment using two or more solutions in sequence.

3.2.3 *solvent system*—specified chemicals or combination of chemicals, that may include corrosion inhibitors, formulated to react with and remove deposits.

### 4. Summary of Test Method

4.1 This test method consists of determining the ability of a dynamic solvent system to dissolve deposits.

4.2 For the unattached deposits, this test method consists of exposing weighed amounts of deposit to the dynamic solvent systems and determining the weight loss of the exposed deposit, thereby determining the efficacy of the solvent system.

4.3 For the attached deposits, the amount and time required to yield a constant amount of certain loss of interest and the amount of deposit not removed determines the relative efficacy of the dynamic solvent system.

### 5. Significance and Use

5.1 This test method is useful because the choice of a solvent system for removing water-formed deposits depends upon the ability of the dynamic solvent system to dissolve both unattached and attached deposits.

### 6. Apparatus

#### 6.1 Common Equipment:

NOTE 1—The equipment listed in this section is basic and serves the function of this test method. This basic test procedure could be modified to meet the specific needs of a particular investigation. The test apparatus, however, must be identified and reported with the results. For comparative type tests, as described in the procedure, it is important that all tests be run in an identical manner.

6.2 *Unattached or Synthetic Deposit Removal* (See Fig. 1 and Fig. 2):

6.2.1 *Balance*, capable of weighing to the nearest 0.1 mg.

6.2.2 *Heating Bath*, thermostatically controlled to  $\pm 1^\circ\text{C}$ .

6.2.3 *Stirrer*, controlled agitation.

6.2.4 *Temperature Indicator*.

6.2.5 *Reaction Flask*, stirred tests are best accomplished in round bottom flasks.

6.2.6 *Condenser*.

6.3 *Attached Deposit Removal* (See Fig. 3):

6.3.1 *Solvent Heater/Solvent Reservoir*.

6.3.2 *Sample Holder*.

6.3.3 *Flow Controller*.

6.3.4 *Sample System* (usually with cooler).

6.3.5 *Pressure Relief*.

<sup>2</sup> Annual Book of ASTM Standards, Vol 11.02.

<sup>3</sup> Annual Book of ASTM Standards, Vol 11.01.

<sup>4</sup> Discontinued; see 1993 Annual Book of ASTM Standards, Vol 11.02.

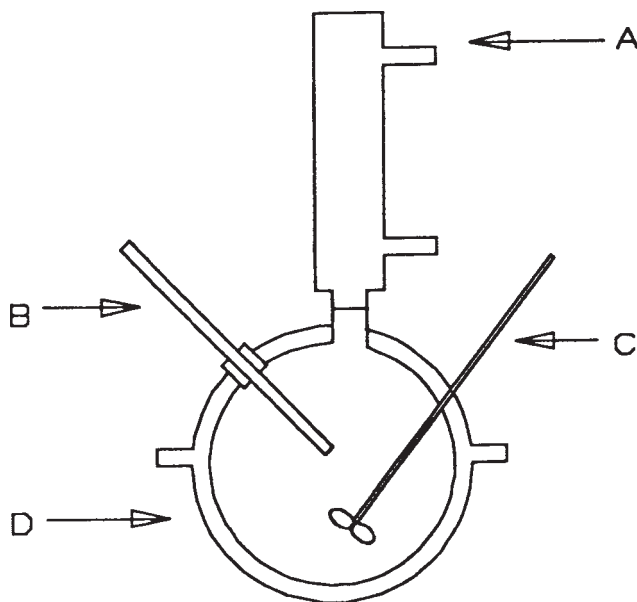

A: Condenser, B: Temperature Measurement, C: Stirrer, D: Heated Reaction Flask

FIG. 1 Low Temperature Test Equipment

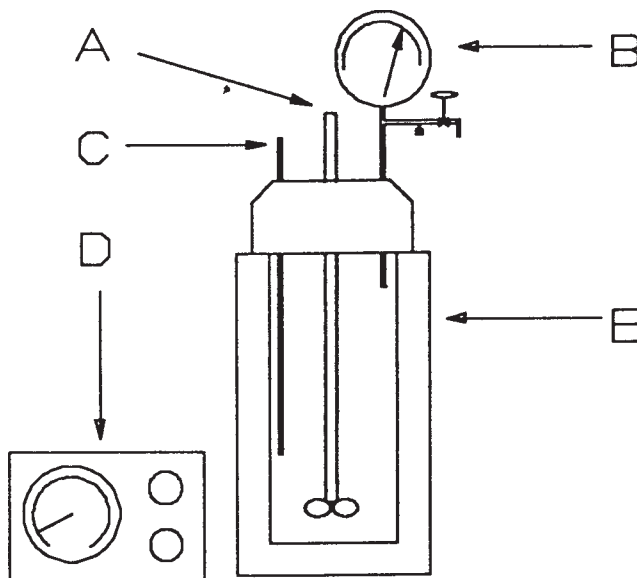

A: Stirrer, B: Pressure Control (Gauge, Vent and Relief), C: Temperature Measurement, D: Temperature Control, E: Heated Autoclave

FIG. 2 High Temperature Test Equipment

6.3.6 Pump.

6.3.7 Flow Meter.

6.3.8 Temperature Controller.

## 7. Reagents

7.1 Purity of Reagents—All solvent materials such as acids, inhibitors, and other additives shall be of the grade normally employed in chemical cleaning practices for the removal of water-formed deposits. Unless otherwise indicated, it is intended that

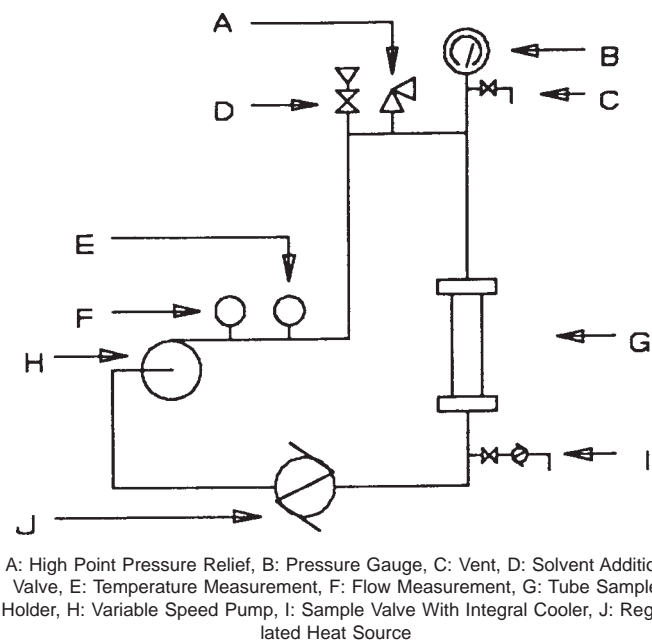

FIG. 3 Dynamic Test Equipment

all chemicals shall conform to the specifications of the Committee on Analytical Reagents of the American Chemical Society,<sup>5</sup> where such specifications are available.

7.2 *Purity of Water*— Unless otherwise indicated references to water shall be understood to mean reagent water conforming to Type II of Specification D 1193.

## 8. Sampling

8.1 Collect and preserve the sample in accordance with Practices D 887 (see Note 2).

NOTE 2—If Method A of Test Methods D 3483 is being used, the deposit removed in that test can be used in this test method.

8.2 Collect and preserve the sample(s) obtained during the cleaning of attached deposit sample.

## 9. Procedure

9.1 Prepare a water solution of the solvent systems to be tested using a weight percentage basis for the acid or other active material including any additives. Add only inhibitors supplied in liquid form on a volume basis as prescribed by the manufacturer.

9.2 *Synthetic or Unattached Deposits:*

9.2.1 Sample preparation shall be in accordance with 9.2 of Test Method D 4743.

9.2.2 Pour a measured volume of the test solvent (see 9.1) into the chosen test apparatus (see Section 6).

9.2.2.1 The weighed deposit can be added to the solvent prior to heating the solvent; however, a controlled and reported temperature must be maintained so that the results between tests can be readily compared.

9.2.3 Heat the solvent to the test temperature while stirring at the specified RPM (see Note 3).

NOTE 3—A stir rate of 60 to 90 RPM is commonly used.

9.2.4 Take a portion of the deposit (see 9.2.1), weigh to the nearest 0.01 g and record an original deposit weight. The deposit weight should meet a solvent volume/deposit weight ratio for this specified application (see Note 4).

NOTE 4—A solvent volume/deposit weight ratio of 100 mL solvent/1 g deposit is commonly used.

9.2.5 After the solvent has stabilized at the test temperature, draw a sample for analysis, then add the deposit to the solvent. This is considered as “time zero.”

9.2.6 If required, samples can be drawn at periodic time intervals. Maintain strict control of all sample weights (to nearest 0.01 g).

9.2.7 At the termination of the test, cool and filter the solvent. Determine the deposit residue weight in accordance with 9.4 and 9.5 of Test Method D 4743.

<sup>5</sup> *Reagent Chemicals, American Chemical Society Specifications*, American Chemical Society, Washington, DC. For suggestions on the testing of reagents not listed by the American Chemical Society, see *Analar Standards for Laboratory Chemicals*, BDH Ltd., Poole, Dorset, U.K., and the *United States Pharmacopeia and National Formulary*, U.S. Pharmaceutical Convention, Inc. (USPC), Rockville, MD.

**9.3 Attached Deposit (Comparative Tests):**

9.3.1 Establish accumulated deposition in accordance with Test Methods D 3483 on a portion of the sample adjacent to and representative of the section to be tested below.

9.3.2 The ratio of the weight of attached deposit on the test specimen to test apparatus volume must be recorded and should be appropriate for the application (see Note 5).

NOTE 5—Due to the constraints imposed by the solvent circulation system, the solvent volume/deposit weight ratio on attached deposits is often larger than desired. This excess capacity can be partially compensated by reducing the concentration of the active components of the solvent. However, in all cases the actual cleaning operation should be designed and controlled according to the accepted practice for the particular solvent system being applied and not according to the values generated by this test method.

9.3.3 Use a measured volume of test solvent to fill the test apparatus.

9.3.4 Establish solvent flow in the test apparatus. The solvent flow should bypass the test specimen until the proper flow rate, system pressure, and solvent temperature is reached.

9.3.4.1 Establish and record the solvent flow rate based on the cross section area of the test specimen.

9.3.5 Heat the solvent to the appropriate test temperature. After the solvent temperature and flow rate have stabilized, draw a sample for analysis.

9.3.6 Establish flow through the test specimen. This is considered as “time zero.”

9.3.7 Monitor and record flow rate, pressure and temperature during the test interval.

9.3.8 Draw samples at periodic time intervals and analyze for ions of choices.

9.3.9 If necessary, use intermediate visual examinations to determine cleaning efficacy.

9.3.10 At the completion of the test period, determined by 9.3.8 and 9.3.9, determine the remaining deposit accumulation according to Test Methods D 3483 (see Note 6). This value as well as the time required to achieve the level of cleanliness is used as the relative measure of cleaning efficacy for attached deposit.

NOTE 6—Since the remaining deposit may be acid insoluble, the preferred method is Method A of Test Methods D 3483.

**10. Calculation**

**10.1 For Synthetic or Unattached Deposits:**

10.1.1 Determine the amount of deposit that was dissolved by subtracting the amount not dissolved (see 9.2.7) from the original deposit weight (see 9.2.4).

10.1.2 Express the efficacy of the solvent system as the percent deposit dissolved, by dividing the amount dissolved (see 10.1.1) by the original amount (see 9.2.4) and converting the resultant decimal to a percentage.

10.1.3 Use the following formula to calculate solvent efficacy:

$$SE = \frac{OS - (FS)}{OS} \times 100 \tag{1}$$

where:

*SE* = solvent efficacy,

*OS* = original deposit weight, g, and

*FS* = final deposit residue weight, g.

**10.2 For Attached Deposits:**

10.2.1 Determine the amount of deposit that was removed by subtracting the final deposit accumulation (see 9.3.10) from the original deposit accumulation (see 9.3.1).

10.2.2 Express the efficacy of the solvent system as the percent of accumulated deposit removed, by dividing the amount removed (see 10.2.1) by the original amount (see 9.3.1) and converting the resultant decimal to a percentage.

10.2.3 Use the following formula to calculate solvent efficacy:

$$SE = \frac{ODA - (FDA)}{ODA} \times 100 \tag{2}$$

where:

*SE* = solvent efficacy,

*ODA* = original deposit accumulation, mg/cm<sup>2</sup>, and

*FDA* = residual deposit accumulation, mg/cm<sup>2</sup>.

**11. Interpretation of Results**

11.1 Use the results of the procedure in this test method to determine if a solvent is be effective in removing the deposit.

11.2 The actual choice of a solvent system to remove the deposit depends not only on the efficacy (see 11.1) but on many other factors as well. Some of these factors are: the compatibility of the solvent with the alloys contained in the system (see Test Methods D 3263); the water requirements of the solvent system; the temperature requirements of the solvent system; the disposal restrictions



of the solvent system; the mechanical requirements to apply the solvent system; and other considerations such as relative cost. 11.3 The results obtained by these test methods should include the type and method of test, the types and concentrations of the solvents tested, the physical parameters involved in the tests, the calculation of the efficacy of the solvents tested and any observations that might be pertinent to choice of a solvent system. To aid in reporting these parameters a guide to reporting is shown in Fig. 4.

12. Precision and Bias

12.1 Because of the many variables involved in the selection of a solvent system (see 11.2), a statement regarding precision and bias would be meaningless and may even be misleading. The user is cautioned to select test conditions as close as possible to his actual system conditions.

12.2 The Results Advisor and Technical Operation Section of the Executive Subcommittee concur that the above precision statement meets the requirements of Practice D 2777.

13. Keywords

13.1 attached; deposit; dynamic; efficacy; removal; scale; solvent; systems; unattached; water formed

ASTM International takes no position respecting the validity of any patent rights asserted in connection with any item mentioned in this standard. Users of this standard are expressly advised that determination of the validity of any such patent rights, and the risk of infringement of such rights, are entirely their own responsibility.

This standard is subject to revision at any time by the responsible technical committee and must be reviewed every five years and if not revised, either reapproved or withdrawn. Your comments are invited either for revision of this standard or for additional standards and should be addressed to ASTM International Headquarters. Your comments will receive careful consideration at a meeting of the responsible technical committee, which you may attend. If you feel that your comments have not received a fair hearing you should make your views known to the ASTM Committee on Standards, at the address shown below.

This standard is copyrighted by ASTM International, 100 Barr Harbor Drive, PO Box C700, West Conshohocken, PA 19428-2959, United States. Individual reprints (single or multiple copies) of this standard may be obtained by contacting ASTM at the above address or at 610-832-9585 (phone), 610-832-9555 (fax), or service@astm.org (e-mail); or through the ASTM website (www.astm.org).

Name of Company Performing The Test \_\_\_\_\_

Solvent System \_\_\_\_\_

Deposit ID \_\_\_\_\_

Duration of Test \_\_\_\_\_ (Hrs)

Temperature \_\_\_\_\_ °C \_\_\_\_\_ °F

Surface or Deposit Weight to Solvent Ratios \_\_\_\_\_

Velocity or Stirring Rate \_\_\_\_\_

Efficiency Calculations \_\_\_\_\_

Visual Observations \_\_\_\_\_

\_\_\_\_\_

\_\_\_\_\_

\_\_\_\_\_

Description of Apparatus \_\_\_\_\_

\_\_\_\_\_

\_\_\_\_\_

\_\_\_\_\_

\_\_\_\_\_

\_\_\_\_\_

FIG. 4 Guide to Reporting