



Standard Test Method for Dissolved Hexavalent Chromium in Water by Ion Chromatography¹

This standard is issued under the fixed designation D 5257; the number immediately following the designation indicates the year of original adoption or, in the case of revision, the year of last revision. A number in parentheses indicates the year of last reapproval. A superscript epsilon (ϵ) indicates an editorial change since the last revision or reapproval.

1. Scope*

1.1 This test method covers procedures for the determination of dissolved hexavalent chromium in wastewater, surface water, and drinking water.

1.2 The precision and bias of this test method has been tested in reagent water and industrial wastewater and has been found suitable over the range of approximately 1 to 1000 $\mu\text{g/L}$. See Table 1 for details. Higher levels can be determined by appropriate dilution.

1.3 Samples containing very high levels of anionic species (that is, chloride, sulfate, etc.) may cause column overload. Samples containing high levels of reducing species (that is, sulfides, sulfites, etc.) may cause reduction of Cr(VI) to Cr(III). This can be minimized by buffering the sample to a pH of 9 to 9.5, filtering it, storing it at 4°C and analyzing it within 24 h.

1.4 The values stated in SI units are to be regarded as the standard.

1.5 *This standard does not purport to address all of the safety concerns, if any, associated with its use. It is the responsibility of the user of this standard to establish appropriate safety and health practices and determine the applicability of regulatory limitations prior to use.*

2. Referenced Documents

2.1 ASTM Standards:

- D 1066 Practice for Sampling Steam²
- D 1129 Terminology Relating to Water²
- D 1192 Specification for Equipment for Sampling Water and Steam in Closed Conduits²
- D 1193 Specification for Reagent Water²
- D 2777 Practice for Determination of Precision and Bias of Applicable Methods of Committee D-19 on Water²
- D 3370 Practices for Sampling Water from Closed Conduits²
- D 5810 Guide for Spiking into Aqueous Samples²
- D 5847 Practice for the Writing Quality Control Specifica-

¹ This test method is under the jurisdiction of ASTM Committee D19 on Water and is the direct responsibility of Subcommittee D19.05 on Inorganic Constituents in Water.

Current edition approved Jan. 10, 2003. Published January 2003. Originally approved in 1992. Last previous edition approved in 1997 as D 5257 – 97.

² *Annual Book of ASTM Standards*, Vol 11.01.

TABLE 1 Determination of Precision and Bias for Hexavalent Chromium

Water Matrix	Amount Added, $\mu\text{g/L}$	Amount Found, $\mu\text{g/L}$	S_r	S_o^A	Bias, %
Reagent	1.2	1.40	0.16	0.15	+ 16.6
	1.6	1.87	0.65	...	+ 16.9
	6.0	6.68	1.03	0.53	+ 11.3
	8.0	8.64	1.10	...	+ 8.0
	16.0	17.4	2.25	0.77	+ 8.8
	20.0	21.4	2.31	...	+ 7.0
	100	101	1.91	3.76	+ 1.0
	140	143	5.52	...	+ 2.1
	800	819	24.3	12.7	+ 2.4
	960	966	18.5	...	+ 7.3
Waste	6.0	5.63	1.17	0.55	-6.2
	8.0	7.31	1.91	...	-8.6
	16.0	15.1	2.70	1.85	-5.6
	20.0	19.8	1.01	...	-1.0
	100	98.9	4.36	3.31	-1.1
	140	138	8.39	...	-1.4
	800	796	60.6	27.1	-0.5
	960	944	72.1	...	-1.7

^AEach Youden pair was used to calculate one lab data point, S_o .

tions for Standard Test Methods for Water Analysis²

2.2 EPA Standard:

EPA Method 218.6 Determination of Dissolved Hexavalent Chromium in Drinking Water, Groundwater and Industrial Wastewater Effluents by Ion Chromatography³

3. Terminology

3.1 *Definitions*—For definitions of terms used in this test method, refer to Terminology D 1129.

3.2 Definitions of Terms Specific to This Standard:

3.2.1 *eluant*—the ionic mobile phase used to transport the sample through the ion exchange column.

3.2.2 *resolution*—the ability of a column to separate constituents under specified test conditions.

4. Summary of Test Method

4.1 A fixed volume of buffered and filtered sample, typically 100 μL , is injected into the eluant flow path and separated by anion exchange using an ammonium sulfate based eluant.

³ Available from Superintendent of Documents, U.S. Government Printing Office, Washington, DC 20402.

*A Summary of Changes section appears at the end of this standard.

4.2 After separation, the sample is reacted with an acidic solution of diphenylcarbohydrazide. Hexavalent chromium reacts selectively with this reagent to form the characteristic violet colored complex.

4.3 The eluant stream passes through a photometric detector for detection of the chromium diphenylcarbohydrazide complex by visible absorbance at 530 nm. Absorbance is proportional to the hexavalent chromium concentration.

5. Significance and Use

5.1 Hexavalent chromium salts are used extensively in the metal finishing and plating industries, in the leather industry as a tanning agent, and in the manufacture of paints, dyes, explosives, and ceramics. Trivalent chromium salts are used as mordants in textile dyeing, in the ceramic and glass industry, and in photography. Chromium, in either oxidation state, may be present in wastewater from these industries and may also be discharged from chromate-treated cooling waters.

5.2 Hexavalent chromium is toxic to humans, animals, and aquatic life. It can produce lung tumors when inhaled and readily induces skin sensitization. It is not known whether cancer will result from ingestion of chromium in any of its valence states.

5.3 Ion chromatography provides a means of separating the hexavalent chromium from other species present in the sample, many of which interfere with other detection methods. The combination of this separation with a sensitive colorimetric detection method provides a selective and sensitive analytical method for hexavalent chromium with minimal sample preparation.

6. Interferences

6.1 By virtue of the chromatographic separation essentially all interfering species are removed from the hexavalent chromium before detection.

6.2 Interferences may result from overloading of the analytical column capacity with high concentrations of anionic species in the sample. Concentrations of chloride ion or sulfate ion up to the equivalent of 1 % NaCl and 3 % Na₂SO₄ do not affect the separation or detection when using an anion exchange column and a 100 µL sample loop.

6.3 The response of 1 mg/L of hexavalent chromium is not affected by 1 g/L of chromic ion.

6.4 Reducing species may reduce hexavalent chromium in acidic matrices. Preservation at a pH 9 to 9.5 will minimize the effect of these species.

6.5 Trace amounts of Cr are sometimes found in reagent grade salts. Since a concentrated buffer solution is used in this test method to adjust the pH of samples, reagent blanks should be analyzed to assess the potential for Cr(VI) contamination. Contamination can also come from improperly cleaned glassware or contact with caustic or acidic reagents with chromium containing stainless steel or pigmented materials.

7. Apparatus

7.1 *Ion Chromatograph*—An ion chromatograph having the following components configured as shown in Fig. 1.

7.1.1 *Pump*, capable of delivering a constant flow in the range of 1 to 5 mL/min at a pressure of 200 to 2000 psi.

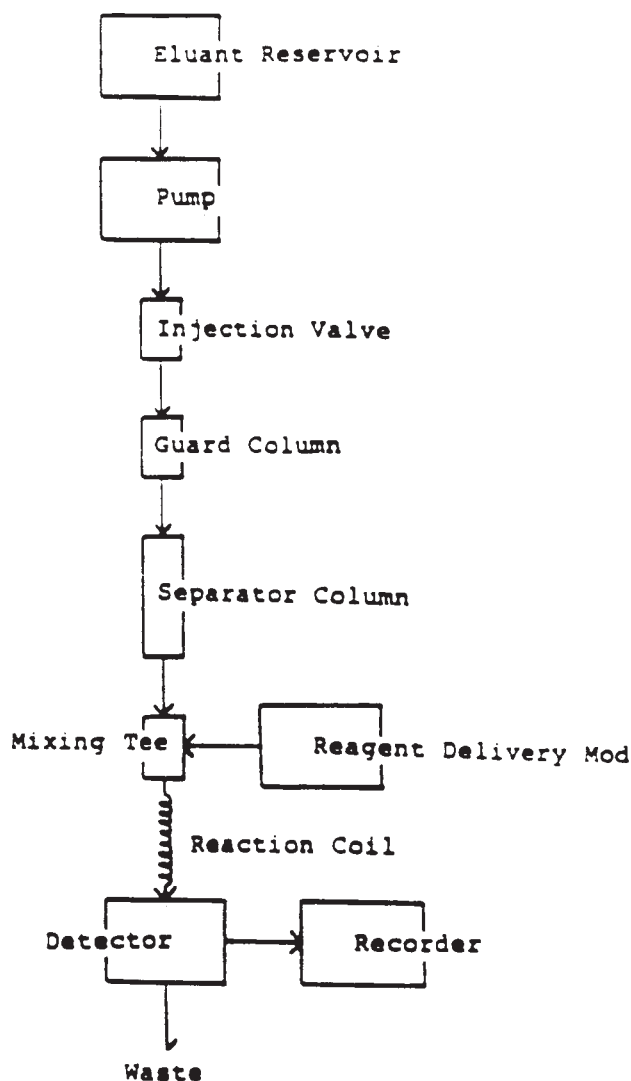

FIG. 1 Diagram of an Ion Chromatograph Using Post-Column Reagent Addition and Photometric Detection

7.1.2 *Injection Valve*— A high pressure, low dead volume valve that allows introduction of 50 to 250 µL of sample into the eluant stream at up to 2000 psi.

7.1.3 *Guard Column*— A column placed before the separator column to protect the separator column from fouling by particles or strongly absorbed organic constituents.

7.1.4 *Analytical Column*—A liquid chromatographic column packed with a polymeric anion exchange resin capable of separating chromate from other anions in a sample containing high total dissolved solids (for example 3 % Na₂SO₄).

7.1.5 *Reagent Delivery Module*—A device capable of delivering 0 to 2 mL/min of reagent against a backpressure of up to 60 psi.

7.1.6 *Mixing Tee and Reaction Coil*—A device capable of mixing two flowing streams providing a sufficient reaction time for post column reaction with minimal band spreading.

7.1.7 *Detector*—A low-volume, flow-through UV-visible absorbance detector with a non-metallic flow path. The recommended detection wavelength for hexavalent chromium is 530 nm.

7.2 *Recorder, Integrator, Computer*—A device compatible with detector output, capable of recording detector response as a function of time for the purpose of measuring peak height or area.

7.3 *Eluant Reservoir*— A container suitable for storing eluant.

7.4 *Syringe*—A syringe equipped with a male luer type fitting and a capacity of at least 1 mL.

7.5 *Summary of Column Requirements:*

7.5.1 *Guard Column*— A short liquid chromatographic column capable of removing organics from the injected sample so as to minimize organic fouling of the separator column.

7.5.2 *Analytical Column*—An anion exchange column capable of providing suitable retention and chromatographic efficiency for chromate ion even in the presence of high amounts of dissolved solids that can occur in wastewater samples. Note that high capacity columns will tolerate higher dissolved solids before becoming overloaded. See Section 13 for details of the columns used in the collaborative test of this test method.

8. Reagents

8.1 *Purity of Reagents*—Reagent grade chemicals shall be used in all tests. Unless otherwise indicated, it is intended that all reagents shall conform to the specifications of the Committee on Analytical Reagents of the American Chemical Society where such specifications are available.⁴ Other grades may be used, provided it is first ascertained that the reagent is of sufficiently high purity to permit its use without lessening the accuracy of the determination.

8.2 *Purity of Water*— Unless otherwise indicated, references to water shall be understood to mean reagent water conforming to Specification D 1193, Type I. Other reagent water types may be used provided it is first ascertained that the water is of sufficiently high purity to permit its use without adversely affecting the bias and precision of the test method. Type II water was specified at the time of round robin testing of this test method.

8.3 *Chromium Solution, Stock (1000 mg Cr/L)*—Dissolve 0.2828 g of potassium dichromate ($K_2Cr_2O_7$) that has been dried at 105°C for 1 h) in water. Add 0.1 mL of eluant concentrate (8.6) to ensure analyte stability. Dilute to 100 mL in a volumetric flask.

8.4 *Chromium Solution, Standard (1000 µg Cr/L)*—Pipet 1.00 mL of chromium stock solution (see 8.3) and 1 mL of eluant concentrate into a 1 L volumetric flask. Dilute to volume with water.

8.5 *Reagent Blank*— Add 1 mL of eluant concentrate (8.6) to a 1 L flask and dilute to volume with the water used to prepare the chromium standards.

8.6 *Eluant Concentrate (2.5 M $(NH_4)_2SO_4$, 1.0 M NH_4OH)*—Dissolve 330 g of ammonium sulfate $(NH_4)_2SO_4$ in

about 500 mL of water. Add 65 mL of concentrated ammonium hydroxide (NH_4OH to sp gr 0.90). Mix well and dilute to 1 L in a volumetric flask.

8.7 *Eluant*—Two different analytical anion exchange columns proved satisfactory in the collaborative test that is summarized in Section 13. Accordingly, the eluant appropriate for each column is described in 8.7.1 and 8.7.2. Eluants should be filtered through a 0.45-µm filter and degassed.

8.7.1 *Eluant for IonPac AS7 Column (0.250 M $(NH_4)_2SO_4$, 0.1 M NH_4OH)*—Add 100 mL of eluant concentrate (8.6) to a 1 L volumetric flask and dilute to volume with water.

8.7.2 *Eluant for IC Pac Anion HC Column (0.025 M $(NH_4)_2SO_4$, 0.01 M NH_4OH)*—Add 10 mL of eluant concentrate (8.6) to a 1 L volumetric flask and dilute to volume with water.

8.8 *Diphenylcarbohydrazide Reagent*—Dissolve 0.5 g of 1,5-diphenylcarbohydrazide in 100 mL of reagent grade methanol. Add to about 500 mL of water containing 28 mL of concentrated sulfuric acid. Dilute with water, while stirring, to 1 L in a volumetric flask. Filter and degas if necessary to ensure reliable delivery.

9. Sampling

9.1 Collect the sample in accordance with the applicable ASTM Standards as follows: Practice D 1066, Specification D 1192, or Practices D 3370.

9.2 Filter samples and adjust pH immediately upon sampling to minimize any interconversion between Cr III and Cr VI species. Filter the sample through a 0.45 µm filter. Collect the filtrate and adjust its pH to 9 to 9.5 using the eluant concentrate (see 8.6). Ship and store samples at 4°C. Bring to ambient temperature prior to analysis. Analyze this stabilized filtrate within 24 h. Adjust final calculations to account for sample dilution.

10. Calibration

10.1 Prepare at least three levels of standards for each decade of the concentration range of interest. For standards of 1 to 1000 µg/L, prepare by diluting measured volumes of the standard chromium solution (see 8.4) with water in separate volumetric flasks.

10.2 Determine the chromium response for each of the standards and blank using the procedure defined in Section 11.

10.3 Prepare a calibration curve by using a linear plot of the peak height or area as a function of standard concentration. Do not force the calibration curve through zero. The response of the reagent blank should be less than 0.1 µg/L hexavalent chromium.

10.4 Prepare a new calibration curve when new reagents are made or the hardware is altered.

11. Procedure

11.1 Set up the ion chromatograph in accordance with the manufacturer's instructions.

11.2 Adjust the eluant flow rate to 1.5 mL/min. Increase the flow of the post-column reagent until the flow rate from the detector outlet line is 2.0 mL/min. so as to have a reagent flow of 0.5 mL/min under operating conditions. Measure the pH of the detector effluent to confirm it is 2 or lower.

⁴ "Reagent Chemicals American Chemical Society Specifications" Am. Chemical Soc., Washington, DC. For suggestions on the testing of reagents not listed by the American Chemical Society, see "Anal. Standards for Laboratory Chemicals," BDH Ltd., Poole, Dorset, U.K., and the "United States Pharmacopeia."

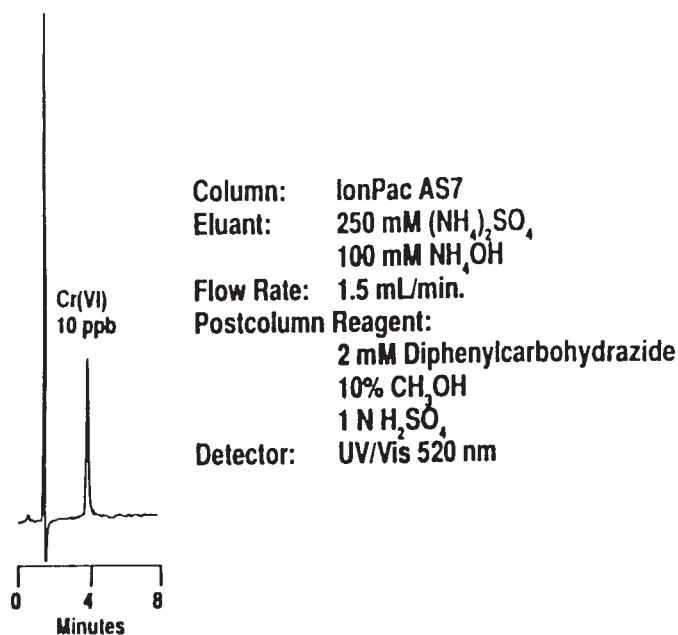

FIGURE 2 ION CHROMATOGRAPHIC DETERMINATION OF HEXAVALENT CHROMIUM

FIG. 2 Ion Chromatographic Determination of Hexavalent Chromium

11.3 After the flow rates are adjusted, allow the system to equilibrate for about 15 min.

11.4 If using a fixed volume sample loop (typically 100 µL), load at least 1 mL of sample through the sample port using an appropriate syringe. Inject the sample into the eluant stream and record the chromatogram (see Fig. 2). If using a variable volume injector, inject the desired sample volume into the eluant stream and record the chromatogram.

12. Calculation

12.1 Refer the hexavalent chromium peak height or peak area to the calibration curve to determine the hexavalent chromium concentration of the injected sample in µg/L.

12.2 For samples that have been diluted, calculate the original hexavalent chromium concentration in µg/L by:

$$\mu\text{g Cr(VI)/L} = C \times F / V.$$

where:

C = µg Cr(VI)/L read from the calibration curve,

F = volume of diluted sample, in mL, and

V = volume of undiluted sample in mL.

13. Precision and Bias

13.1 The following separator columns were used in the collaborative test high capacity separator column⁵ and low capacity separator column.⁶

⁵ Model IonPac A57 column, available from Dionex Corporation, 1228 Titan Way, Sunnyvale, CA 94088, has been found suitable for this purpose.

⁶ Model IC Pac Anion HC, available from Millipore Corporation (Waters Division), 34 Maple Street, Milford, MA 01757.

13.2 The collaborative test of this test method was performed in reagent water and wastewater by fifteen laboratories using one operator each. For reagent water the test used ten levels of concentration comprised of five Youden pairs ranging from 1.2 to 960 µg/L of hexavalent chromium. For wastewater the test used eight levels of concentration comprised of four Youden pairs ranging from 6 to 960 µg/L of hexavalent chromium. The precision and bias data are presented in Table 1. See the Annex for a detailed description of the collaborative test.

13.3 The results of this collaborative test can also be summarized as follows:

Number of laboratories: 15
 Range tested: 1.2 to 960 µg/L
 Matrix: Reagent Water:
 $S_o = 0.033x + 0.106$
 $S_r = 0.050x + 0.559$
 Mean Recovery = 1.04x + 0.183
 Matrix: Wastewater:
 $S_o = 0.041x + 0.039$
 $S_r = 0.059x + 1.05$
 Mean Recovery = 0.989x + -0.41

13.4 This section on precision and bias conforms to Practice D 2777 – 77 which was in place at the time of collaborative testing. Under the allowances made in 1.4 of D 2777 – 98, these precision and bias data do meet existing requirements of interlaboratory studies of Committee D19 test methods.

14. Quality Control

14.1 In order to be certain that analytical values obtained using these test methods are valid and accurate within the confidence limits of the test, the following QC procedures must be followed when analyzing hexavalent chromium.

14.2 Calibration and Calibration Verification:

14.2.1 Analyze at least three working standards containing concentrations of hexavalent chromium that bracket the expected sample concentration, prior to analysis of samples, to calibrate the instrument. The calibration correlation coefficient shall be equal to or greater than 0.990. In addition to the initial calibration blank, a calibration blank shall be analyzed at the end of the batch run to ensure contamination was not a problem during the batch analysis.

14.2.2 Verify instrument calibration after standardization by analyzing a standard at the concentration of one of the calibration standards. The concentration of a mid-range standard should fall within ±15 % of the known concentration.

14.2.3 If calibration cannot be verified, recalibrate the instrument.

14.3 Initial Demonstration of Laboratory Capability:

14.3.1 If a laboratory has not performed the test before, or if there has been a major change in the measurement system, for example, new analyst, new instrument, etc., a precision and bias study must be performed to demonstrate laboratory capability.

14.3.2 Analyze seven replicates of a standard solution prepared from an Independent Reference Material containing a mid-range concentration of hexavalent chromium. The matrix and chemistry of the solution should be equivalent to the solution used in the collaborative study. Each replicate must be

taken through the complete analytical test method including any sample preservation and pretreatment steps. The replicates may be interspersed with samples.

14.3.3 Calculate the mean and standard deviation of the seven values and compare to the acceptable ranges of bias in Table 1. This study should be repeated until the recoveries are within the limits given in Table 1. If a concentration other than the recommended concentration is used, refer to Practice D 5847 for information on applying the *F* test and *t* test in evaluating the acceptability of the mean and standard deviation.

14.4 *Laboratory Control Sample (LCS)*:

14.4.1 To ensure that the test method is in control, analyze a LCS containing a known concentration of hexavalent chromium with each batch or 10 samples. If large numbers of samples are analyzed in the batch, analyze the LCS after every 10 samples. The laboratory control samples for a large batch should cover the analytical range when possible. The LCS must be taken through all of the steps of the analytical method including sample preservation and pretreatment. The result obtained for a mid-range LCS shall fall within $\pm 15\%$ of the known concentration.

14.4.2 If the result is not within these limits, analysis of samples is halted until the problem is corrected, and either all the samples in the batch must be reanalyzed, or the results must be qualified with an indication that they do not fall within the performance criteria of the test method.

14.5 *Method Blank*:

14.5.1 Analyze a reagent water test blank with each batch. The concentration of hexavalent chromium found in the blank should be less than 0.5 times the lowest calibration standard. If the concentration of hexavalent chromium is found above this level, analysis of samples is halted until the contamination is eliminated, and a blank shows no contamination at or above this level, or the results must be qualified with an indication that they do not fall within the performance criteria of the test method.

14.6 *Matrix Spike (MS)*:

14.6.1 To check for interferences in the specific matrix being tested, perform a MS on at least one sample from each batch by spiking an aliquot of the sample with a known concentration of hexavalent chromium and taking it through the analytical method.

14.6.2 The spike concentration plus the background concentration of hexavalent chromium must not exceed the high calibration standard. The spike must produce a concentration in the spiked sample that is 2 to 5 times the analyte concentration in the unspiked sample, or 10 to 50 times the detection limit of the test method, whichever is greater.

14.6.3 Calculate the percent recovery of the spike (*P*) using the following formula:

$$P = 100 [A(V_s + V) - B V_s] / C V \quad (1)$$

where:

- A* = analyte concentration (mg/L) in spiked sample,
- B* = analyte concentration (mg/L) in unspiked sample,
- C* = concentration (mg/L) of analyte in spiking solution,
- V_s* = volume (mL) of sample used, and
- V* = volume (mL) added with spike.

14.6.4 The percent recovery of the spike shall fall within the limits, based on the analyte concentration, listed in Guide D 5810, Table 1. If the percent recovery is not within these limits, a matrix interference may be present in the sample selected for spiking. Under these circumstances, one of the following remedies must be employed: the matrix interference must be removed, all samples in the batch must be analyzed by a test method not affected by the matrix interference, or the results must be qualified with an indication that they do not fall within the performance criteria of the test method.

NOTE 1—Acceptable spike recoveries are dependent on the concentration of the component of interest. See Guide D 5810 for additional information.

14.7 *Duplicate*:

14.7.1 To check the precision of sample analyses, analyze a sample in duplicate with each batch. If the concentration of the analyte is less than five times the detection limit for the analyte, a matrix spike duplicate (MSD) should be used.

14.7.2 Calculate the standard deviation of the duplicate values and compare to the precision in the collaborative study using an *F* test. Refer to 6.4.4 of Practice D 5847 for information on applying the *F* test.

14.7.3 If the result exceeds the precision limit, the batch must be reanalyzed or the results must be qualified with an indication that they do not fall within the performance criteria of the test method.

14.8 *Independent Reference Material (IRM)*:

14.8.1 In order to verify the quantitative value produced by the test method, analyze an Independent Reference Material (IRM) submitted as a regular sample (if practical) to the laboratory at least once per quarter. The concentration of the IRM should be in the concentration mid-range for the method chosen. The value obtained must fall within the control limits established by the laboratory.

15. Keywords

15.1 analysis; hexavalent chromium; ion chromatography; wastewater; water

(Mandatory Information)

A1. DUPLICATION OF QUALITY CONTROL MEASURES

A1.1 The precision and bias data cited in this test method were the result of a collaborative test designed and executed jointly by ASTM Committee D-19 on Water and the U.S. EPA Environmental Monitoring and Support Laboratory (Cincinnati). Participants were required to use this method or EPA Method 218.6, or both. These two methods are technically equivalent. The eleven reagent water samples consisted of a reagent water blank and five Youden pairs. The nine wastewater samples consisted of a waste-water blank and four Youden pairs. The following is a duplication of the test instructions that included the quality control measures that were part of this test method:

A1.2 Preparation

A1.2.1 Calibration Standard Preparation:

A1.2.1.1 A standard concentrate (green label) has been furnished with this study to minimize calibration standard biases. The Cr(VI) concentration contained within the standard concentrate ampul and the study range are listed in Table A1.1.

A1.2.1.2 Prepare a calibration curve according to 9.1 of EPA Method 218.6, revision 3.2 using a series of calibration standards prepared from the standard concentrate. The calibration curve must range from 1.0 µg/L to 1000 µg/L.

A1.2.2 Matrix Blanks:

A1.2.2.1 An analysis of each matrix water is required to determine potential background concentrations of Cr(VI). These blanks are referred to as *reagent water blank* and *wastewater blank*. The wastewater blank should be adjusted to pH 9.0 to 9.5 with the buffer solution (section 7.9, EPA Method 218.6) and passed through a 0.45 µm filter before analysis. Analyze a portion of the wastewater solution prepared in A1.2.4.2 as the blank.

A1.2.3 Quality Control Sample Preparation:

A1.2.3.1 Prepare the QC sample (laboratory fortified blank (LFB) as described in section 10.3.2, Method 218.6, revision 3.2) by pipetting a 1.0 mL aliquot from the QC sample concentrate ampul (blue label) and diluting to 100 mL with reagent water. The Cr(VI) concentration in the QC sample and the acceptance limits that are to be used for this study are presented in Table A1.2.

A1.2.4 Sample Preparation:

A1.2.4.1 Reagent Water Samples:

(a) (a) Prepare the reagent water samples by transferring a 1.0 mL aliquot from each ampul labelled reagent water (yellow labels) to individual 100 mL volumetric flasks and dilute to volume with reagent water. These samples are now ready for analysis.

TABLE A1.1 Standard Ampul Concentration and Study Range

Analyte	MDL, µg/L	STANDARD Ampul, µg/L	Study Range, µg/L
Cr(VI)	0.4	100,000	1–1000

TABLE A1.2 Quality Control Sample Acceptance Limits

Analyte	True Value (T.V.)	Acceptance Limits ^A
	µg/L	µg/L
Cr(VI)	40.0	36–44

^ADefined as T.V. ± 10 %.

A1.2.4.2 Wastewater Samples:

(a) (a) Collect at least 1 liter of a wastewater of your choice. Filter the wastewater matrix through a 0.45 µm filter then adjust the pH of the filtrate to 9.0 to 9.5 by adding dropwise a solution of the buffer (8.2, EPA Method 218.6). Prepare the individual wastewater samples by transferring a 1.0 mL aliquot from each ampul labelled wastewater (orange labels) to individual 100 mL volumetric flasks and dilute to volume with the pH adjusted wastewater. These samples are now ready for analysis. The wastewater matrix is not to be diluted prior to spiking regardless of the Cr(VI) background concentration.

A1.3 Sample Analyses

A1.3.1 Analyze each prepared sample in the order defined in Table A1.3. The sample names and numbers in Table A1.3 are the same as those on the data report forms. Be certain that the sample data is entered under the correct sample name.

A1.4 Quality Control (QC)

A1.4.1 The QC sample is used to perform regular checks on the calibration curve. Only one QC sample need be prepared. However, three analyses of this QC sample will be required; one immediately following the last calibration standard, another immediately following the reagent water sample series,

TABLE A1.3 EPA Method Study 218.6 Injection Order

Sample Name and Sample Order
QC Sample
Reagent Water Blank
Reagent Water—Sample #1
Reagent Water—Sample #2
Reagent Water—Sample #3
Reagent Water—Sample #4
Reagent Water—Sample #5
Reagent Water—Sample #6
Reagent Water—Sample #7
Reagent Water—Sample #8
Reagent Water—Sample #9
Reagent Water—Sample #10
QC Sample
Wastewater Blank
Wastewater—Sample #11
Wastewater—Sample #12
Wastewater—Sample #13
Wastewater—Sample #14
Wastewater—Sample #15
Wastewater—Sample #16
Wastewater—Sample #17
Wastewater—Sample #18
QC Sample

and the third immediately following the wastewater sample series. If the Cr(VI) concentration in the QC sample falls outside of the acceptance limits found in Table A1.2, the analyst should reanalyze the QC sample. If the Cr(VI) concentration falls within the acceptance limits, continue with the sample analyses. If the Cr(VI) concentration is still outside of the acceptance limits, a new calibration curve is required and must be confirmed by a successful QC analysis before sample analyses can continue.

A1.5 Data Report Forms

A1.5.1 Analytical values reported on the data report forms must not be corrected for matrix background concentrations.

Report measured concentrations of Cr(VI) as $\mu\text{g/L}$ to three significant figures (that is, 2.35, 23.5, or 235).

A1.6 Questionnaire

A1.6.1 Operate your ion chromatograph according to manufacturer specifications and recommendations found in EPA Method 218.6 (revision 3.2) and the equivalent Test Method D 5257. A questionnaire is enclosed to record your specific operating conditions and equipment type.

SUMMARY OF CHANGES

This section identifies the location of selected changes to these test methods that have been incorporated since the last issue. For the convenience of the user, Committee D19 has highlighted those changes that may impact the use of these test methods. This section may also include descriptions of the changes or reasons for the changes, or both.

(1) The QC section was added to the test method.

(2) Section 13.4 was added.

ASTM International takes no position respecting the validity of any patent rights asserted in connection with any item mentioned in this standard. Users of this standard are expressly advised that determination of the validity of any such patent rights, and the risk of infringement of such rights, are entirely their own responsibility.

This standard is subject to revision at any time by the responsible technical committee and must be reviewed every five years and if not revised, either reapproved or withdrawn. Your comments are invited either for revision of this standard or for additional standards and should be addressed to ASTM International Headquarters. Your comments will receive careful consideration at a meeting of the responsible technical committee, which you may attend. If you feel that your comments have not received a fair hearing you should make your views known to the ASTM Committee on Standards, at the address shown below.

This standard is copyrighted by ASTM International, 100 Barr Harbor Drive, PO Box C700, West Conshohocken, PA 19428-2959, United States. Individual reprints (single or multiple copies) of this standard may be obtained by contacting ASTM at the above address or at 610-832-9585 (phone), 610-832-9555 (fax), or service@astm.org (e-mail); or through the ASTM website (www.astm.org).