



Designation: D 4096 – 91 (Reapproved 1997)<sup>ε1</sup>

## Standard Test Method for Determination of Total Suspended Particulate Matter in the Atmosphere (High-Volume Sampler Method)<sup>1</sup>

This standard is issued under the fixed designation D 4096; the number immediately following the designation indicates the year of original adoption or, in the case of revision, the year of last revision. A number in parentheses indicates the year of last reapproval. A superscript epsilon ( $\epsilon$ ) indicates an editorial change since the last revision or reapproval.

<sup>ε1</sup> NOTE— Editorial corrections were made in December 1997.

### 1. Scope

1.1 This test method provides for sampling a large volume of atmosphere, 1600 to 2400 m<sup>3</sup> (55 000 to 85 000 ft<sup>3</sup>), by means of a high flow-rate vacuum pump at a rate of 1.13 to 1.70 m<sup>3</sup>/min (40 to 60 ft<sup>3</sup>/min) (**1, 2, 3 and 4**).<sup>2</sup>

1.2 This flow rate allows suspended particles having diameters of less than 100  $\mu\text{m}$  (stokes equivalent diameter) to be collected. However, the collection efficiencies for particles larger than 20  $\mu\text{m}$  decreases with increasing particle size and it varies widely with the angle of the wind with respect to the roof ridge of the sampler shelter and with increasing speed (**5**). When glass fiber filters are used, particles within the size range of 100 to 0.1  $\mu\text{m}$  diameters or less are ordinarily collected.

1.3 The upper limit of mass loading will be determined by plugging of the filter medium with sample material, which causes a significant decrease in flow rate (see 6.4). For very dusty atmospheres, shorter sampling periods will be necessary. The minimum amount of particulate matter detectable by this method is 3 mg (95 % confidence level). When the sampler is operated at an average flow rate of 1.70 m<sup>3</sup>/min (60 ft<sup>3</sup>/min) for 24 h, this is equivalent to 1 to 2  $\mu\text{g}/\text{m}^3$  (**3**).

1.4 The sample that is collected may be subjected to further analyses by a variety of methods for specific constituents.

1.5 Values stated in SI units shall be regarded as the standard. Inch-pound units are shown for information only.

1.6 *This standard does not purport to address all of the safety concerns, if any, associated with its use. It is the responsibility of the user of this standard to establish appropriate safety and health practices and determine the applicability of regulatory limitations prior to use.*

### 2. Referenced Documents

#### 2.1 ASTM Standards:

<sup>1</sup> This test method is under the jurisdiction of ASTM Committee D-22 on Sampling and Analysis of Atmospheres and is the direct responsibility of Subcommittee D22.03 on Ambient Atmospheres and Source Emissions.

Current edition approved Sept. 15, 1991. Published February 1992. Originally published as D 4096 – 82. Last previous edition D 4096 – 89.

<sup>2</sup> The boldface numbers in parentheses refer to the list of references at the end of this practice.

D 1356 Terminology Relating to Sampling and Analysis of Atmospheres<sup>3</sup>

D 3631 Test Methods for Measuring Surface Atmospheric Pressure<sup>3</sup>

E 1 Specification for ASTM Thermometers<sup>4</sup>

#### 2.2 Other Documents:

EPA-600/9-76-005 Quality Assurance Handbook for Air Pollution Measurement Systems, Vol I, Principles (December 1984 Rev.)<sup>5</sup>

EPA-600/4-77-027a Quality Assurance Handbook for Air Pollution Measurement Systems, Vol II, Ambient Air Specific Methods<sup>5</sup>

### 3. Terminology

3.1 *Definitions*—For definitions of other terms used in this test method, refer to Terminology D 1356.

#### 3.2 Descriptions of Terms:

3.2.1 *absolute filter*—a filter or filter medium of ultra-high collection efficiency for very small particles (submicrometre size) so that essentially all particles of interest or of concern are collected. Commonly, the efficiency is in the region of 99.95 % or higher for a standard aerosol of 0.3- $\mu\text{m}$  diameter (see Practice D 2986).

3.2.2 *Hi-Vol (The High-Volume Air Sampler)*—a device for sampling large volumes of an atmosphere, collection of the contained particulate matter by filtration, and consisting of a high-capacity air mover, a filter to collect suspended particles, and means for measuring, or controlling, or both, the flow rate.

3.2.3 *primary flow-rate standard*—a device or means of measuring flow rate based on direct primary observations, such as time and physical dimensions.

3.2.4 *secondary flow-rate standard*—A flow-rate-measuring device, such as an orifice meter, that has been calibrated against a primary standard.

3.2.5 *spirometer*—a displacement gasometer consisting of an inverted bell resting upon or sealed by liquid (or other

<sup>3</sup> Annual Book of ASTM Standards, Vol 11.03.

<sup>4</sup> Annual Book of ASTM Standards, Vol 14.03.

<sup>5</sup> Available from U.S. Environmental Protection Agency, Environmental Monitoring Systems Laboratory, Quality Assurance Division, Research Triangle Park, NC 27711. Attn: Distribution Record System.



means) and capable of showing the amount of gas added to or withdrawn from the bell by the displacement (rise or fall) of the bell.

3.2.6 *working flow-rate standard*—a flow rate measuring device, such as an orifice meter, that has been calibrated against a secondary flow-rate standard. The working flow-rate standard is used to calibrate a flow measuring or flow rate indicating instrument.

3.2.7 *constant flow high-volume sampler*—a high volume sampler that is equipped with a constant flow control device.

#### 4. Summary of Test Method

4.1 This test method describes typical equipment, operational procedures, and a means of calibration of the equipment using an orifice flowrate meter. (See also Annex A1.)

4.2 Air is drawn into a covered housing and through a filter by means of a high-flow-rate air mover, so that particulate material collects on the filter surface.

4.3 The amount of particulate matter accumulated on the filter over a specified period of time is measured by weighing a preweighed filter after exposure. The flow rate of air sampled is measured over the test period. The result is expressed in terms of particulate mass collected (or loading) per unit volume of air sampled, usually as micrograms per cubic metre ( $\mu\text{g}/\text{m}^3$ ). The volume of air sampled is recorded by measurement of the device flow rate(s).

4.4 The volume of air sampled is determined by means of a flow-rate indicator. The instrument flow-rate indicator is calibrated against a reference orifice meter. The latter is a working standard which, in turn, has been calibrated against a secondary flow meter certified by the U.S. National Institute of Standards and Technology.

4.5 Airborne particulate matter retained on the filter may be examined or analyzed by a variety of methods. Specific procedures are not included in this method but are the subject of separate standard methods.

#### 5. Significance and Use

5.1 The Hi-Vol sampler is commonly used for the collection of the airborne particulate component of the atmosphere. Some physical and chemical parameters of the collected particulate matter are dependent upon the physical characteristics of the collection system and the choice of filter media. A variety of options available for the Hi-Vol sampler give it broad versatility and allow the user to develop information about the size and quantity of airborne particulate material and, using subsequent chemical analytical techniques, information about the chemical properties of the particulate matter.

5.2 This test method presents techniques that when uniformly applied, provide measurements suitable for intersite comparisons.

5.3 This test method measures the atmosphere presented to the sampler with good precision, but the actual dust levels in the atmosphere can vary widely from one location to another. This means that sampler location may be of paramount importance, and may impose far greater variability of results than any lack of precision in the method of measurement. In particular, localized dust sources may exert a major influence over a very limited area immediately adjacent to such sources.

Examples include unpaved streets, vehicle traffic on roadways with a surface film of dust, building demolition and construction activity, or nearby industrial plants with dust emissions. In some cases, dust levels measured close to such sources may be several times the community wide levels exclusive of such localized effects (see Practice D 1357).

#### 6. Interferences

6.1 Large extraneous objects, such as insects, may be swept into the filter and become weighed unnoticed.

6.2 Liquid aerosols, such as oil mists and fog droplets, are retained by the filter. If the amount of liquid so collected is sizable, the filter can become wet and its function and mass impaired.

6.3 Any gaseous or vaporous constituent of the atmosphere under test that is reactive with or sorptive upon the filter or its collected matter will be retained and weighed as particulate matter.

6.4 As the filter becomes loaded with collected matter, the sampling rate is reduced. If a significant drop in flow rate occurs, the average of the initial and final flow rate calculated in 10.1 will not give an accurate estimate of total flow during the sampling period. The magnitude of such errors will depend on the amount of reduction of airflow rate and on the variation of the mass concentration of dust with time during the 24-h sampling period. As an approximate guideline, any sample should be suspect if the final flow rate is less than one half the initial rate. A continuous record of flow rate will indicate the occurrence of this problem, or a constant-flow high-volume sampler may be used to eliminate the problem.

6.5 The possibility of power failure or voltage change during the test period would lead to an error, depending on the extent and time duration of such failure. A continuous record of flow rate is desirable.

6.6 The passive loading of the filter that can occur if it is left in place for any time prior to or following a sampling period can introduce significant error. For unattended operation, a sampler equipped with shutters shall be used.

6.7 If two or more samplers are used at a given location, they should be placed at least 2 m (6 ft) apart so that one sampler will not affect the results of an adjacent sampler.

6.8 Wind tunnel studies have shown significant possible sampling errors as a function of sampler orientation in atmospheres containing high relative concentrations of large particles (5).

6.9 Metal dusts from motors, especially copper, may significantly contaminate samples under some conditions.

6.10 Under some conditions, atmospheric  $\text{SO}_2$  and  $\text{NO}_x$  may interfere with the total mass determination (6).

#### 7. Apparatus

7.1 The essential features of a typical high-volume sampler are shown in the diagram of Fig. 1 and Fig. 2. It is a compact unit consisting of a protective housing, an electric motor-driven, high-speed, high-volume air mover, a filter holder capable of supporting a 203 by 254-mm (8 by 10-in.) filter at the forward or entrance end, and at the exit end, means for either indicating or controlling the air flow rate, or both, over the range of 1.13 to 1.70  $\text{m}^3/\text{min}$  (40 to 60  $\text{ft}^3/\text{min}$ ). Designs

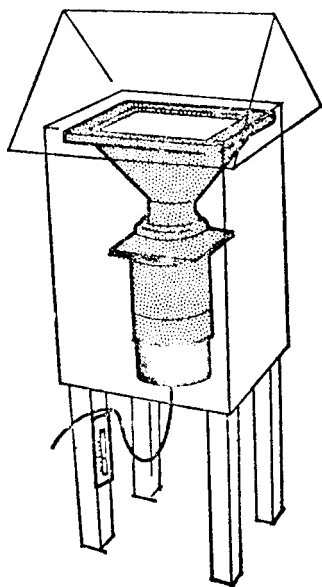

NOTE 1—The clearance area between the main housing and the roof at its closest point should be  $580.5 \pm 129.0 \text{ cm}^2$  ( $90 \pm 20 \text{ in.}^2$ ). The main housing should be rectangular, with dimensions of about 290 by 360 mm ( $11\frac{1}{2}$  by 14 in.).

**FIG. 1 Assembled Sampler and Shelter**

also exist in which a flow controller is located between the filter and the blower. For unattended operation, a sampler equipped with shutters to protect the filter is required.

7.2 A calibrator kit is required. This contains a working flow-rate standard of appropriate range in the form of an orifice with its own calibration curve. The kit includes also a set of five flow-control plates. These kits are available from most supply houses that deal in apparatus for air sampling and analysis.

7.3 A large desiccator or air conditioned room is required for filter conditioning, storage, and weighing. Filters must be stored and conditioned at a temperature of 15 to 27°C and a relative humidity between 0 and 50 %.

7.4 An analytical balance capable of reading to 0.1 mg, and having a capacity of at least 5 g is necessary. It is very desirable to have a weighing chamber of adequate size with a support that is capable of accommodating the filter without rolling or folding it or exposing it to drafts during the weighing operation.

7.5 *Barograph or Barometer*, capable of measuring to the nearest 0.1 kPa (1 mm Hg) meeting the requirements of Test Methods D 3631.

7.6 *Thermometer*—ASTM Thermometer 33C, meeting the requirements of Specification E 1.

7.7 *Clock*, capable of indicating  $24 \text{ h} \pm 2 \text{ min}$ .

7.8 *Flow-Rate Recorder*, capable of recording to the nearest  $0.03 \text{ m}^3/\text{min}$  ( $1.0 \text{ ft}^3/\text{min}$ ).

7.9 *Differential Manometer*, capable of measuring to 4 kPa (40 mm Hg).

## 8. Reagents and Materials

### 8.1 Filter Medium:

8.1.1 In general, the choice of a filter medium will depend on the purpose of the test. For any given standard test method

the appropriate medium will be specified. However, it is important to be aware of certain filter characteristics that can affect selection and use.

8.1.2 *Glass-Fiber Filter Medium*—This type is most widely used for determination of mass loading. Weight stability with respect to moisture is an attractive feature. High-efficiency or absolute types are preferred and will collect all airborne particles of practically every size and description. The following characteristics are typical:

Fiber content	All-glass-usually mixed sizes
Binder	Below 5 % (zero for binderless types)
Thickness	Approximately 0.5 mm
Pinholes	None
DOP smoke test (Practice D 2986)	0.05 % penetration, 981 Pa (100 mm of water) at 8.53 m/min (28 ft/min)

Particulate matter collected on glass-fiber medium can be analyzed for many constituents. If chemical analysis is contemplated binderless filters should be used. It must be borne in mind, however, that glass is a commercial product generally containing test-contaminating materials. The high ratio of surface area to glass volume permits extraction of such contaminants, especially if strong reagents are employed.

8.1.3 *Silica Fiber Filters*—Where it may be required or desirable to use a mineral fiber filter, which may later be extracted by strong reagents, silica fiber filters can be used. Such fibers are usually made by leaching glass fibers with strong mineral acids followed by washing with deionized water. The fibers are rather weak but can be formed into filter sheets using little or no binder. These filters are commercially available (7).

8.1.4 *Cellulose Papers*—For some purposes it is desirable to collect airborne particles on cellulose fiber filters. Low-ash papers are especially useful where the filter is to be destroyed by ignition or chemical digestion. However, these papers have higher flow resistance (lower sampling rate) and have been reported to have much poorer collection efficiency than the glass fiber media (8). Furthermore, cellulose is very sensitive to moisture conditions and even with very careful conditioning before and after sampling it is difficult to make an accurate weighing of the collected particles. It is usually necessary to do the weighing with the filter enclosed in a lightweight metal can with a tight lid.

## 9. Procedure

9.1 The Hi-Vol sampler can be used in a number of ways. Variations of procedure may include the kind of filter medium, the surface area of the filter, flow velocity through the filter, prescreening to exclude particles up to a given size, and the manner of placing and exposing the filter during the test. The procedure most commonly used will be described here.

9.2 Calibrate the sampler as described in the Annex. Do not make any change or adjustment on the sampler flow indicator after calibrating. Remove the calibrating orifice.

9.3 Mark the filters for identification, condition them in a large desiccator or conditioned room and allow them to remain for 24 h at 15 to 27°C and 0 to 50 % relative humidity. Weigh the sheets carefully on an analytical balance to the fourth decimal place (0.1 mg). Glass or silica fiber papers are very stable to moisture and one such preparation cycle is usually adequate. If a special binding has been used in making the

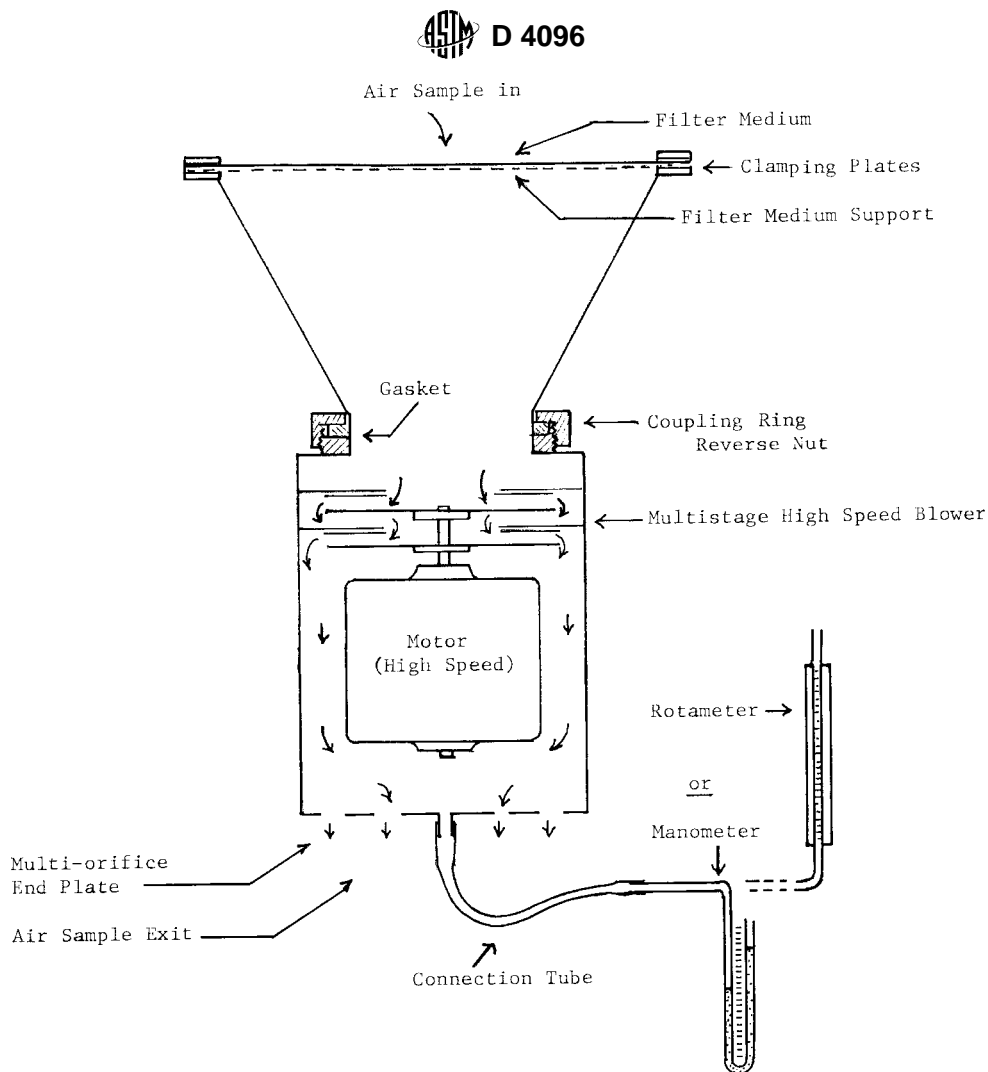

**FIG. 2 Schematic Section of a Typical High-Volume Sampler**

sheet, this could introduce a higher moisture sensitivity.

9.3.1 During the conditioning and weighing operation it may be necessary to roll the filter to form a tube about 50 mm in diameter to facilitate handling and weighing. Do not fold.

9.4 The filters may be packed into a box with sheets of glassine between the filters or they may be individually packed in sealable plastic bags or in cassettes for transportation to the field.

9.5 Mount the filter sheet in the filter holder taking care not to lose any of the fiber. Clamp it in place by means provided. Either side of the filter may face outward, but the filter may be sealed into place easier by facing the smooth side into the housing if there is a difference in texture.

9.5.1 If the filter holder is separate from the sampler, mount the holder on the intake port, making sure that the coupling gasket is in place and that it is tight.

9.6 Place the sampler in the position and location called for in the test. This is with the filter face up, in a horizontal plane, and inside a housing, as shown in Fig. 1. The dimensions and clearances specified are intended to provide uniformity in sampling practice.

9.7 Start the sampler motor and record the time and date. Read the flow-rate indicator and record this reading and the corresponding flow rate as read from the calibration curve.

Note also the temperature and barometric pressure. An electric clock should be connected to the same line as the motor so as to detect any loss of test time due to power interruption. A continuous record of the sampling flow rate and sampling time can be obtained by the use of a continuous pressure (or flow rate) recorder.

9.8 Allow the sample to run for the specified length of time. This is commonly 24 h. During the time of the sampling period, take several readings of flow rate, temperature, and barometric pressure with final set of readings at the end of sampling period. If only initial and final readings are made, assume that the change of readings is linear over the period of test. Intermediate readings will improve the accuracy of volume measurement. A continuous chart record is best.

9.9 At the end of the sampling period record all final readings. Remove the filter from the mount very carefully so as not to lose any of the fiber material or collected particulate matter. Fold the filter in half upon itself with the collected material enclosed within. Place the folded filter in a clean tight envelope and mark it for identification. In some applications it may be desirable to place the used filter in a tight metal container to prevent any loss or damage to the filter.

9.10 In the laboratory remove the filter from its container. Tap the container and knock any loose fiber or particulate



matter onto the inside surface of the folded filter. Examine the inside surface and, with a pair of tweezers, remove any accidental objects such as insects. Place the filter in a desiccator or conditioned room. After 24 h at the same temperature and humidity used for initial conditioning (see 9.3), remove and weigh on the analytical balance to the nearest 0.1 mg. It may be necessary to repeat the operation to verify that the final weight is stable. Subtract the previously determined tare weight of the filter. Record the difference as the weight of collected material.

NOTE 1—Most particulate samples are sufficiently stable to show a reasonably constant weight. If a sample contains a significant amount of a highly hygroscopic material, such as calcium chloride from winter time road salt, it may be difficult to obtain an accurate reproducible weight on the final sample.

## 10. Calculation

10.1 Calculate volume of air sampled as follows:

$$V = \frac{Q_i + Q_f}{2} \times T \quad (1)$$

$V$  = air volume sampled,  $m^3$ ,  
 $Q_i$  = initial air flow rate,  $m^3/min$ ,  
 $Q_f$  = final air flow rate,  $m^3/min$ , and  
 $T$  = sampling time, min.

10.2 Calculate the concentration of suspended particles by dividing the weight of collected particulate matter by the total volume of air sampled during the test period as follows:

$$S.P. = \frac{(W_f - W_i) \times 10^6}{V} \quad (2)$$

where:

$S.P.$  = mass concentration of suspended particles,  $\mu g/m^3$ ,  
 $W_i$  = initial weight of filters, g,  
 $W_f$  = final weight of filter, g,  
 $V$  = air volume sampled,  $m^3$ , and  
 $10^6$  = conversion of g to  $\mu g$ .

### 10.3 Flowrate Correction:

10.3.1 The calibrator kit (working standard) is a sharp-edge orifice flow-rate meter. The Hi-Vol flow-rate indicator itself is also a sharp-edge orifice flow-rate meter, although it may have several orifices of equal size instead of one large orifice. Both devices operate on the same physical principle. In each case, the flow velocity is most simply expressed by the relation:

$$u = C\sqrt{2g(\Delta h)} \quad (3)$$

where:

$u$  = the average flow velocity in the orifice,  
 $C$  = the orifice constant (may be taken as 0.61),  
 $g$  = acceleration due to gravity, and  
 $\Delta h$  = the fluid head across the orifice expressed in terms of the fluid flowing (air in this case) and as measured by the differential manometer.

For a given orifice of specified area:

$$Q = uS \quad (4)$$

where:

$Q$  = the volume flowrate through orifice area  $S$ .

10.3.2 When using the same flow-rate orifice under different

sets of conditions of temperature or atmospheric pressure, or both, apply a correction in recognition of the corresponding change in air sample density and value of  $\Delta h$ . From Eq 3 and Eq 4, it can be developed that:

$$Q_2 = Q_1 \left[ \frac{T_2 P_1}{T_1 P_2} \right]^{1/2} \quad (5)$$

where:

$Q_2$  = flowrate (for a given flowmeter) at barometric pressure  $P_2$  and absolute temperature  $T_2$ ,

$Q_1$  = flowrate (of the same flowmeter) at barometric pressure  $P_1$  and absolute temperature  $T_1$

$Q_2$  = flowrate at  $P_2$  and  $T_2$ , and

$Q_1$  = flowrate of  $P_1$  and  $T_1$ .

Since each of the quantities  $Q_2/Q_1$ ,  $T_2/T_1$ , and  $P_1/P_2$  are expressed as ratios, values for each pair of quantities can be expressed in any consistent units.

10.3.3 The chart furnished with the calibration kit shall state the temperature and atmospheric pressure at which its calibration was done. The correction shown by use of Eq 5 shall then be applied for each data point determined with the calibration kit (if either  $T$  or  $P$  is much different from the original calibrating condition). Eq 5 shall also be applied when the Hi-Vol, already calibrated at one set of conditions, is used for sampling at a different set of conditions.

10.3.4 Numerical values for volume rate  $Q$  as determined above are for the temperature and pressure conditions at which the measurements were made. To convert to standard conditions:

$$Q_s = Q_o \times \left[ \frac{T_s \times P_o}{T_o \times P_s} \right]^{1/2} \quad (6)$$

where:

$Q_s$  = the volume flowrate expressed as at standard conditions,

$Q_o$  = the observed volume flowrate,

$T_s$  = the standard temperature, 298 K (25°C),

$T_o$  = the absolute temperature at which  $Q_o$  was determined,

$P_s$  = the standard barometric pressure, 101.3 kPa (760 mm Hg), and

$P_o$  = the barometric pressure at which  $Q_o$  was determined.

## 11. Report

11.1 Report the result as micrograms of particulate matter per cubic metre of air. When reporting, state the test conditions, such as any particle size exclusion, size and type of filter, duration of test, sample volume, barometric pressure, temperature, date, and place of test.

## 12. Precision and Bias <sup>6</sup>

12.1 *Precision*—Based upon collaborative testing, the relative standard deviation (coefficient of variation) for single analyst variation (repeatability of the method) is 3.0 %. The corresponding value for multilaboratory variation (reproducibility of the method) is 3.7 % (3).

<sup>6</sup> Supporting data are available from ASTM Headquarters. Request RR: D22-1005.



12.2 *Bias*—Since no standard atmosphere exists to provide a primary standard as a basis for comparison with measured values, no statement of accuracy can be formulated. Several factors inherent in the method itself make it impossible to provide a primary standard. These factors will affect the amount of material collected, in part because particles of different size are affected differently by sampling variables. For example, the dimensions of the shelter and the flow rate are instrumental in establishing aerodynamic flow patterns that determine which particle size ranges are collected and which are excluded. The orientation of the sampler with respect to wind direction has also been shown in laboratory experiments to affect the sampling results (5). Passive loading during unattended exposure of the filter has been shown in field experiments to have a statistically significant effect at the 0.05 level of confidence. (10).

### 13. Alternate Techniques

13.1 The Hi-Vol sampler is a versatile tool and may be used in a number of ways other than just described. Various standard test procedures may refer to this standard yet prescribe specific or special conditions of operation. Following are some typical possibilities:

13.1.1 Where only a short time is possible, as in a spot test for a given time of day, a small and more open filter can be used. In this way a high flow velocity is achieved with particle collection efficiency dependent on the impaction mechanism. The smaller filter adds to convenience and accuracy of weighing. The size is commonly a disk 100 mm (4 in.) in diameter.

13.1.1.1 Various special papers are available as filters for such high velocity sampling. One is composed of synthetic and mineral fibers that are insensitive to moisture and so are very weight stable.

13.1.2 Where it may be desirable to weigh only the respirable portion of airborne particulate matter, it is both feasible and practical to mount a size-selective cyclone collector or impactor stage ahead of the filter. This gives a more uniform value of dust loading since the relatively few random but weight-dominating large particles are not included. Such devices often have inlets that are cylindrical, avoiding the directionality of the gabled roof inlet described here (11).

### 14. Keywords

14.1 atmosphere; Hi-Vol; high volume; particulate; suspended

## ANNEX

### (Mandatory Information)

#### A1. CALIBRATION

A1.1 A closure plate at the discharge end of the sampler is perforated with a number of circular orifices. The pressure drop across this orifice plate provides a measure of instrument air flow rate at any time. The indicating means may be a small rotameter tapped into the back plate or it may be a water manometer or other pressure-responsive device. In any case, this sampler flowmeter must be calibrated against some standard to assure accuracy of results.

A1.2 *Method of Calibration*—A simple and sufficiently accurate method of calibrating is to compare the sampler meter with an orifice meter (working standard) that has been calibrated against a primary or master standard such as a Root's meter.

A1.2.1 The primary standard is preferably a spirometer of sufficient capacity to allow an accurate time-volume reading. This would be at least 30 s as determined by a stopwatch.

A1.2.2 It is possible and acceptable to use a positive displacement pump or blower as a master flow-rate standard. In this case, the delivery rate of the master standard must be known accurately and the equipment must be in sound mechanical condition (no bypass leakage).

A1.3 *Calibration Procedure*—Remove the filter holder from the sampler unit. Insert one of the resistance plates in the coupling end of the calibrator making sure there is a gasket on each side of the plate. Mount the calibrator on the sampler as

shown in Fig. A1.1 or Fig. A1.2. Connect its pressure tap to a water manometer covering the orifice calibration range.

NOTE A1.1—Samplers equipped with a flow controlling device must have the flow-controlling function rendered inoperative to allow changes to be made during calibration of the flow indicator, if possible. For samplers using critical flow regulation, this procedure is inappropriate and alternative means of calibration are supplied by the manufacturer (11).

A1.3.1 If the sampler meter is a manometer or other pressure device, the resistance plates may be taken in any order and a set of calibration readings taken with each. For each separate plate, and while the sampler is running, record the calibrator orifice pressure drop and the corresponding manometer pressure at the backplate tap. Plot the calibrator flow rates against the sampler manometer readings. This is then the flow rate chart to be used with that sampler.

A1.3.2 If the sampler flow meter is a rotameter, select the resistance plate that is at the center of the series. Mount the plate (with gaskets) and operate the sampler. Read the calibrator manometer and determine the flow rate from its calibration chart. The rotameter reading may not match. In this case, adjust the rotameter flow control valve until the rotameter reading does match the calibrator reading. Do not change this valve setting again unless the sampler is to be recalibrated. Operate with each of the remaining resistance plates and record both calibrator flow rate and the rotameter reading. Make a table of the data and from this table plot a calibration chart. If the

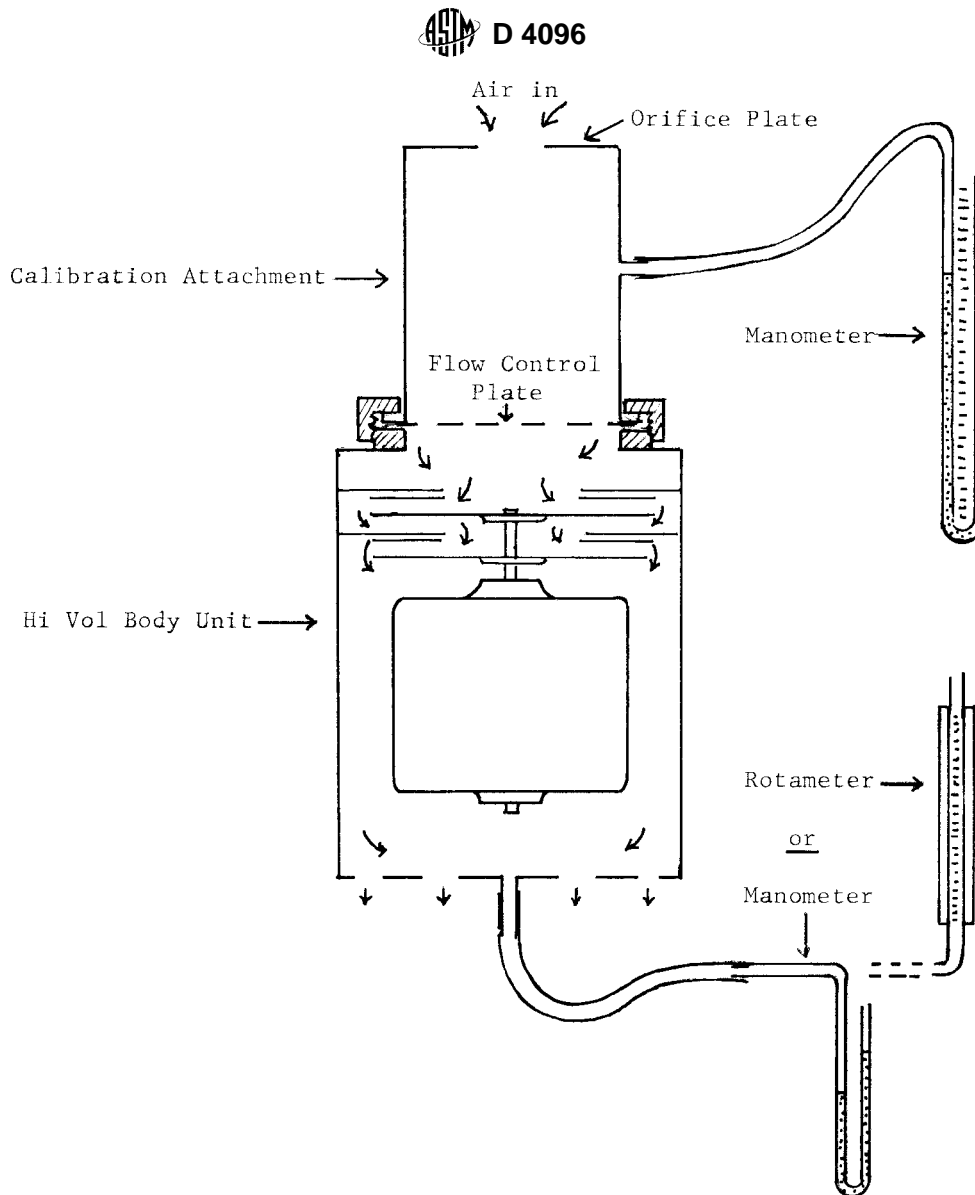

**FIG. A1.1 Schematic Section Showing Use of the Calibration Attachment Blower Housing Mount**

readings match at all points of the chart, the rotameter reading can be taken directly; otherwise, apply whatever correction is shown by the chart.

NOTE A1.2—If the sampler is equipped with a flow control device which has been made inactive during the calibration of the flow indicator, make the flow control device operative again after the calibration procedure is completed.

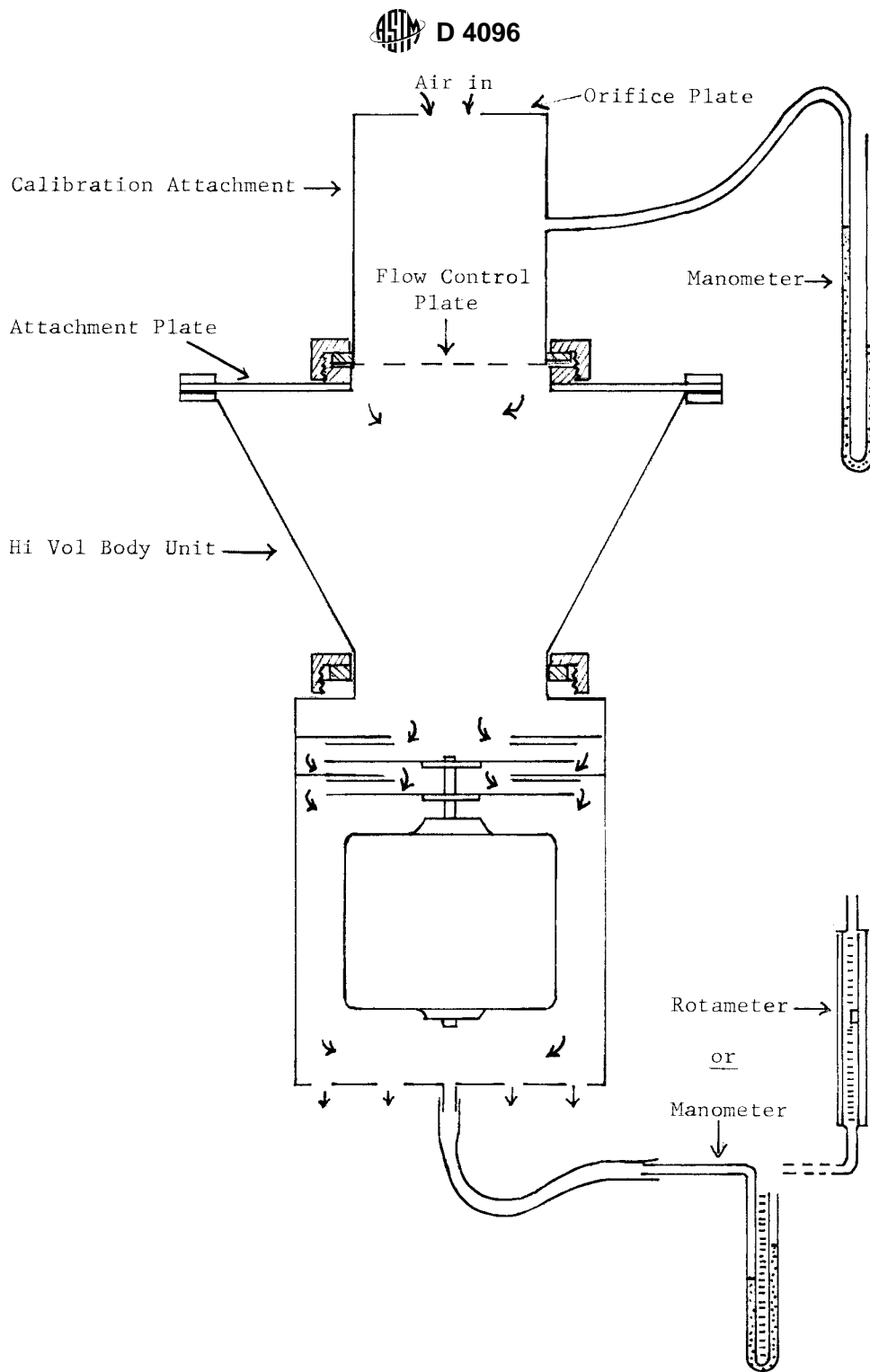

FIG. A1.2 Schematic Section Showing Use of Calibration Attachment Filter Holder Mount

## REFERENCES

- (1) Reference Method for the Determination of Suspended Particulates in the Atmosphere (High Volume Method), *Federal Register*, Vol 36, No. 84, Part II, Friday, April 30, 1971.
- (2) "Recommended Method of Analysis for Suspended Particulate Matter in the Atmosphere: (High Volume Method)," *Methods of Air Sampling and Analysis*, Second Edition, Inter-Society Committee. Published by American Public Health Association, Washington, DC, 1977, pp. 578-585.
- (3) McKee, H. C., et al, "Collaborative Testing of Methods to Measure Air Pollutants, I, The High-Volume Method for Suspended Particulate Matter," *Journal of the Air Pollution Control Association*, 22, No. 5, May 1972, pp. 342-347.





**D 4096**

- (4) Ambient Air Quality Monitoring, 40 CFR 58, Federal Register Vol 44 No. 92, 27558–27604.
- (5) Wedding, J. B., McFarland A. R., and Cermak, J. E., “Large Particle Collection Characteristics of Ambient Aerosol Samplers,” *Environmental Science and Technology*, 1977, Vol. 11, pp. 387–390
- (6) Fennelly, P. F., “The Origin and Influence of Airborne Particulates,” *American Scientist*, Vol 64, 1976, 46–56.
- (7) Benson, A. L., Levins, P. L., Massucco, A. A., Sparrow, D. B., and Valentine, J. R., “Development of a High Purity Filter for High Temperature Particulate Sampling and Analysis,” *Journal of the Air Pollution Control Association*, Vol 25, No. 3, March 1975, pp. 274–277.
- (8) Smith, W. J., and Surprenant, N. F., “Properties of Various Filtering Media for Atmospheric Dust Sampling,” *Proceedings*, ASTM, Vol 55, 1955.
- (9) *Calibration in Air Monitoring*, ASTM STP 598, ASTM, 1976.
- (10) Communication from Allegheny County Health Department, Bureau of Air Pollution Control, 301 39th Street, Pittsburgh, PA 15201, Sept. 28, 1990.
- (11) “High-Volume Measurement of Size Classified Particulate Matter,” *Methods of Air Sampling and Analysis*, J. P. Lodge, Jr., ed., 3rd edition, Inter-Society Committee, Published by Lewis Publishers, Inc., Chelsea, MI, pp. 421–439.

*ASTM International takes no position respecting the validity of any patent rights asserted in connection with any item mentioned in this standard. Users of this standard are expressly advised that determination of the validity of any such patent rights, and the risk of infringement of such rights, are entirely their own responsibility.*

*This standard is subject to revision at any time by the responsible technical committee and must be reviewed every five years and if not revised, either reapproved or withdrawn. Your comments are invited either for revision of this standard or for additional standards and should be addressed to ASTM International Headquarters. Your comments will receive careful consideration at a meeting of the responsible technical committee, which you may attend. If you feel that your comments have not received a fair hearing you should make your views known to the ASTM Committee on Standards, at the address shown below.*

*This standard is copyrighted by ASTM International, 100 Barr Harbor Drive, PO Box C700, West Conshohocken, PA 19428-2959, United States. Individual reprints (single or multiple copies) of this standard may be obtained by contacting ASTM at the above address or at 610-832-9585 (phone), 610-832-9555 (fax), or service@astm.org (e-mail); or through the ASTM website (www.astm.org).*