



Standard Practice for Full-Scale Chamber Determination of Volatile Organic Emissions from Indoor Materials/Products¹

This standard is issued under the fixed designation D 6670; the number immediately following the designation indicates the year of original adoption or, in the case of revision, the year of last revision. A number in parentheses indicates the year of last reapproval. A superscript epsilon (ε) indicates an editorial change since the last revision or reapproval.

1. Scope

1.1 This practice is intended for determining volatile organic compound (VOC) emissions from materials and products (building materials, material systems, furniture, consumer products, etc.) and equipment (printers, photocopiers, air cleaners, etc.) under environmental and product usage conditions that are typical of those found in office and residential buildings.

1.2 This practice is for identifying VOCs emitted and determining their emission rates over a period of time.

1.3 This practice describes the design, construction, performance evaluation, and use of full-scale chambers for VOC emission testing.

1.4 While this practice is limited to the measurement of VOC emissions, many of the general principles and procedures (such as methods for evaluating the general performance of the chamber system) may also be useful for the determination of other chemical emissions (for example, ozone, nitrogen dioxide). Determination of aerosol and particle emissions is beyond the scope of this document.

2. Referenced Documents

2.1 ASTM Standards:

- D 1356 Terminology Relating to Sampling and Analysis of Atmospheres²
- D 1914 Practice for Conversion Units and Factors Relating to Sampling and Analysis of Atmospheres²
- D 3686 Practice for Sampling Atmospheres to Collect Organic Compound Vapors (Activated Charcoal Tube Adsorption Method)²
- D 5116 Guide for Small-Scale Environmental Chamber Determinations of Organic Emissions From Indoor Materials/Products²
- D 5197 Test Method for Determination of Formaldehyde and Other Carbonyl Compounds in Air (Active Sampler Methodology)²
- D 5466 Test Method for Determination of Volatile Organic

Chemicals in Atmospheres (Canister Sampling Methodology)²

D 6196 Practice for Selection of Sorbents and Pumped Sampling/Thermal Desorption Analysis Procedures for Volatile Organic Compounds in Air²

D 6345 Guide for Selection of Methods for Active, Integrative Sampling of Volatile Organic Compounds in Air²

E 779 Test Method for Determining Air Leakage Rate by Fan Pressurization³

E 1333 Test Method for Determining Formaldehyde Concentrations in Air and Emission Rates from Wood Products Using a Large Chamber⁴

IEEE/ASTM SI 10 - Standard for Use of the International System of Units (SI): The Modern Metric System⁵

2.2 Other Documents:

ACGIH 1995 (American Conference of Governmental Industrial Hygienists), Threshold Limit Values (TLVs) for Chemical Substances and Physical Agents in the Work Environment and Biological Exposure Indices. Cincinnati, OH

ASHRAE 1999, ASHRAE 62-99 "Ventilation for Acceptable Indoor Air Quality," American Society of Heating, Refrigerating, and Air-Conditioning Engineers. Atlanta, GA

CMEIAQ (Consortium for Material Emissions and Indoor Air Quality) Final Report 1.1 A Method for Sampling and Analysis of Volatile Organic Compounds in Emission Testing of Building Materials. Institute for Research in Construction, National Research Council Canada, Ottawa, Ontario K1A 0R6, Canada

CMEIAQ Final Report 3.1 Models for Predicting Volatile Organic Compound (VOC) Emissions from Building Materials, Institute for Research in Construction, National Research Council Canada, Ottawa, Ontario K1A 0R6, Canada

ECA-IAQ (European Collaborative Action) "Indoor Air Quality and Its Impact on Man," 1997. Total volatile organic compounds (TVOCs) in indoor air quality investigations. Report No. 19. EUR 17675 EN. Luxembourg:

¹ This practice is under the jurisdiction of ASTM Committee D22 on Sampling and Analysis of Atmospheres and is the direct responsibility of Subcommittee D22.05 on Indoor Air.

Current edition approved May 10, 2001. Published July 2001.

² Annual Book of ASTM Standards, Vol 11.03.

³ Annual Book of ASTM Standards, Vol 04.11.

⁴ Annual Book of ASTM Standards, Vol 04.10.

⁵ Annual Book of ASTM Standards, Vol 14.04.

Office for Official Publications of the European Community

U.S. EPA Compendium of Methods for Determination of Toxic Organic Compounds in Ambient Air, Report EPA-600/4-89/017 available through the National Technical Information Service, Springfield, VA 22161; PB90-116989. This report contains TO-17

World Health Organization, 1989 "Indoor Air Quality: Organic Pollutants," EURO Reports and Studies No. 111, World Health Organization, Copenhagen, pp. 1-64

3. Terminology

3.1 *Definitions*—or definitions and terms commonly used in ASTM standards, including this standard, refer to Terminology D 1356. For an explanation of units, symbols, and conversion factors, refer to Practice D 1914.

3.2 *Definitions of Terms Specific to This Standard:*

3.2.1 *chamber loading ratio*—the total amount of test specimen divided by the net air volume of the environmental test chamber in $1/m^3$, m/m^3 , m^2/m^3 , and m^3/m^3 for unit, line, area, and volume emission sources, respectively (see 3.2.4).

3.2.2 *clean air*—defined in this practice as air that satisfies all of the following criteria:

(1) concentrations of total VOCs $\leq 10 \mu\text{g}/m^3$;

(2) concentration of any individual compound to be measured $\leq 2.0 \mu\text{g}/m^3$;

(3) particle concentrations ≤ 100 particles/ m^3 of $0.5 \mu\text{m}$ diameter or larger (that is, the Class M2 according to ASHRAE 1995 (1)⁶ clean room requirement for $>0.5 \mu\text{m}$ diameter particles;

(4) concentrations of ozone and other potentially reactive species such as nitrogen oxides (NO_x) and sulfur oxides (SO_x) should be at or below detectable levels (for example, $<10 \mu\text{g}/m^3$).

3.2.3 *clean air change rate (1/h)*—the flow rate of clean air (defined in 3.2.2) in m^3/h supplied into the chamber divided by the net air volume (in m^3) of the environmental test chamber (that is, volume of an empty chamber minus the volume taken by all contents in the chamber during testing such as the test specimen, sampling ports). The clean air flow rate may be measured directly at the clean air supply duct. The clean air change rate can also be determined by conducting a tracer gas test (for example, a tracer gas decay test) in the chamber. Note that the air exchange rate (in units of 1/h) is abbreviated as ACH.

3.2.4 *emission factor*—the mass of a VOC or total VOC emitted per unit time and per unit amount of source tested. Depending on the type of source, the amount of source may be expressed by its exposed surface area (that is, an area source such as a painted gypsum wallboard surface), its dominant dimension (that is, a line source such as a caulk or sealant), its mass, or its standard setup (that is, a "unit" source such as a predefined work station system). As a result, the unit for the emission factor will be mg/h , $\text{mg}/(m \text{ h})$, $\text{mg}/(m^2h)$, $\text{mg}/(\text{kg h})$,

and $\text{mg}/(m^3h)$ for the "unit," line, area, mass, and volume emission sources, respectively.

3.2.5 *emission rate*—the mass of a VOC or total VOC emitted from all the test specimen(s) present in the space per unit time, mg/h . It is equal to the emission factor times the amount of emission source.

3.2.6 *full-scale chamber*—a room-size chamber that can house the material/product to be tested in its real dimensions, and provide the required environmental conditions (temperature, relative humidity, and air velocity) that are similar to the material/product use in full-scale room conditions.

3.2.7 *time zero*—the start time when the emission factor is measured. It will depend on the purpose of the testing. For example, time zero may be defined as the time when the test specimen is loaded into the chamber if the test specimen is prepared outside the chamber. Alternatively, when the emission during an application process (for example, painting) is to be tested, time zero may be defined as the time when the application begins.

3.2.8 *total volatile organic compound (TVOC)*—the sum of the concentrations of all the individual VOCs captured from air by a given sorbent, or a given combination of several sorbents, thermally desorbed into and eluted from a given gas chromatographic system, and measured by a given detector. For VOC definition, see Terminology D 1356.

NOTE 1—The measured value of TVOC will depend on the collection and desorption efficiency of the sorbent trap; the efficiency of transfer to the GC column; the type and size of the GC column; the GC temperature program and other chromatographic parameters; and the type of GC detector.

3.2.9 *tracer gas*—a gaseous compound that can be used to determine the mixing characteristics of the test chamber and be a cross-check of the air change rate. The tracer gas must not be emitted by the test specimen and must not be contained in the supply air.

4. Summary of Practice

4.1 Materials or products are placed in a full-scale test chamber within which temperature, relative humidity, and air change rate are controlled according to set parameters. Air is sampled at the exhaust of or inside the chamber, and analyzed by appropriate methods to identify the major emitted compounds and their concentrations as a function of time. The measured concentrations are then used to determine the emission rates, and/or the emission characteristics of the material or product. This information can be used to assess the contribution of the materials and products to the concentrations in the space of interest (for example, the occupied zone).

5. Significance and Use

5.1 VOCs emitted from materials/products affect indoor air quality (IAQ) in buildings. To determine the impact of these emissions on IAQ, it is necessary to know their emission rates over time. This practice provides guidelines for using a full-scale environmental chamber for testing large materials and full-scale material systems/assemblies.

5.2 While this practice is developed for measuring VOC emissions, the chamber facilities and methods of evaluation presented in this practice are also useful for a variety of

⁶ The boldface numbers in parentheses refer to the list of references at the end of this practice.

purposes including: (1) testing the emissions during the application process (for example, painting), or other related sources; (2) developing scaleup methods (for example, from small chamber results to a full-scale scenario); (3) studying the interaction between sources and sinks, and validating source/sink models which are the basis for IAQ prediction; and (4) testing interactions between source emissions and other compounds in the air (for example, NO_x, ozone, SO_x).

6. Principles

6.1 Tests Under Uniform Chamber Concentration Conditions—Assuming that the concentration of each emitted VOC tested in the chamber air is uniform as a result of good mixing, the concentration is then governed by the mass balance equation:

$$V \frac{dC(t)}{dt} = R(t) - QC(t) - S(t) \quad (1)$$

where:

V = air volume of the chamber excluding air volume taken by test specimens, m³;

t = time, h;

$C(t)$ = concentration of the emitted VOC in the air exhausted from the chamber (can be measured at the chamber return or exhaust air ducts), mg/m³;

$R(t)$ = emission rate of the source(s) in the chamber, mg/h;

Q = clean air flow rate supplied to the chamber (measured at clean air supply duct or determined by a tracer gas test), m³/h; and,

$S(t)$ = sink term representing loss (or re-emission if negative) of the VOC due to adsorption/desorption effect on the interior surfaces of the chamber and ducts, mg/h (see section 8.6 for its determination).

Based on Eq 1, the VOC emission rates of a test specimen as a function of time can be determined by measuring the concentrations of the air exhausted from the chamber and the clean airflow rate (refer to Section 11 for the actual calculation procedure). The concentrations and clean airflow rate must be determined for the same temperature condition since the air volume changes with air temperature. For example, when testing products that generate significant heat (for example, copiers), the exhaust air temperature will be higher than the supply air temperature. If the concentration is measured at the chamber exhaust while airflow rate is measured at the chamber supply, the supply airflow rate must be first adjusted to the equivalent airflow rate under the exhaust air temperature (that is, multiplied by the ratio of exhaust to supply air temperature in degrees Kelvin) before it is used for determining the emission rate.

Note that, in addition to the uniform VOC concentration assumption, Eq 1 also assumes no chemical reaction in the chamber, no air entry into the chamber other than the supply air, and a negligible VOC concentration at the supply air, compared to that measured at the chamber exhaust. The validity of using Eq 1 depends on how well the chamber's actual operation meets these assumptions. Therefore, the performance of the chamber must be evaluated against certain criteria in order to obtain reliable and reproducible test results (see Section 8).

6.2 Tests Under Non-Uniform Concentration Conditions—The full-scale chamber system can also be used to simulate the room airflow conditions in real buildings, which are not necessarily well mixed (for example, in the case of a displacement ventilation system). In this case, the VOC concentrations measured within a defined occupied zone in the chamber (for example, concentrations measured at the center of or various locations within the chamber) can be used directly to simulate the impact of the test materials/products on the VOC concentration levels in the room under a specified material/product loading ratio and ventilation rate conditions that are similar to those expected in real buildings. Such tests may be useful in evaluating complex field situations. However, a detailed understanding of air movement and emission dynamics for each simulation is necessary in order to extrapolate the test results to other field situations.

Typical airflow patterns and air distributions in ventilated spaces may be simulated by appropriate designs of supply air diffusers and return air grilles with appropriate recirculated airflow rate if the goal is to assess emissions under realistic airflow conditions. The total air change rate (outdoor/clean airflow rate plus the recirculated airflow rate) in office buildings may range from 1.0 to 9.0/h, depending on the heating/cooling requirements for the space. Typical types of air diffusers and airflow patterns in ventilated rooms are described in ASHRAE 1997c (1).⁶

6.3 Variables Affecting Emission Rates—The emission of pollutants from indoor materials/products generally involves three mass transfer processes: (1) diffusion of pollutants from within the material to the surface; (2) thermal dynamic mass equilibrium conditions at the material/air interface (that is, at the surface); and (3) convection from the surface to the ambient air. Variables affecting emission rates include those related to the materials/products themselves (emitting source variables) and those related to the environment within which they are tested or used (environmental variables). Other factors that may affect emission rates include chemical reactions or operating conditions of the test product (for example, emissions from office machines may depend upon conditions of use).

6.3.1 Emitting Source Variables—Emitting source variables include the physical and chemical properties of the materials/products/application such as chemical composition, density, thickness, internal structure, surface characteristics, and ways materials are applied. These are related to raw materials, additives, the manufacturing processes, and operating conditions. These variables influence the type of VOCs that are emitted, their diffusion coefficients within the material, their adsorption/desorption equilibrium constants over the surface, and ultimately their emission rate profiles.

The physical and chemical properties of manufactured products may change with time and may be affected by environmental conditions. Therefore, it is necessary to know the age of materials or products to be tested. It is also important to document the history (for example, environmental conditions during storage and transportation periods before testing) of the test specimens from their manufacture until testing. If the goal of the testing is to compare the emission characteristics of different materials or products of the same type, all test

specimens should be approximately the same age and have approximately the same history of exposure to environmental conditions.

6.3.2 Environmental Variables—Local environmental conditions can significantly affect VOC emissions. Major factors include temperature, relative humidity, air motion (velocity and turbulence), and VOC concentrations in the ambient air. The ventilation rate in test chambers (or building space) and the loading (amount of product used in a certain space volume) also affect the VOC emissions, since they affect the local VOC concentrations and airflow conditions in the chamber/space. These environmental factors can change the VOC emission rates at any given time and, therefore, produce different emission profiles. The following sections briefly review the effects of these environmental factors.

6.3.2.1 Temperature—An increase in the temperature of the materials and or the ambient air can result in an increase in diffusivities and evaporative mass transfer coefficients. More importantly, increasing temperature will significantly increase the vapor pressure of VOCs. For instance, a temperature increase from 23 to 33 °C will increase the mass transfer coefficient for decane by only 6 %, but will increase the vapor pressure for decane by 83 %. This will lead to an increase in VOC emission rates, since emission rate is proportional to the vapor pressure of the VOC for “wet” emitting sources. The strength of this temperature effect depends on specific materials and VOCs emitted according to Wolkoff 1998 (2) and Van der Wal et al. 1997 (3). Relationships between the ambient air temperature and emission rates have yet to be developed. Full-scale chamber tests are currently conducted under a standard temperature (for example, 23 ± 0.5 °C for non heat-generating products). Specimens are, therefore, preconditioned under the same temperature before testing.

For products that generate significant heat (for example, copy machines), a relatively large variation of air temperature and airflow pattern in the chamber may be present due to the convective heat transfer from the test product. Ideally, the chamber air temperature should be controlled to typical indoor air temperatures when evaluating heat generating devices, as happens in mechanically ventilated buildings [Brown, 1999 (4)]. Where this is not possible due to limitations of the chamber system, the test protocol should define the chamber operating procedures consistent with the test objectives and the test protocol should address the impact of temperature on determination and comparability of emission rates.

6.3.2.2 Relative Humidity—Relative humidity may affect emissions of pollutants that are hydrophilic or pollutants generated by chemical reactions with water. It may also affect VOC emissions from materials that are hygroscopic since the adsorbed water may change the diffusion properties of the material and how the VOC desorbs from the surface. For emission sources that contain water (for example, water-based paints, water-based cleaners, and water-based adhesives), relative humidity may have a profound impact on the VOC emissions because it controls the rate of water evaporation from the source. The extent to which the relative humidity

affects VOC emissions depends on specific materials and VOCs emitted according to Wolkoff 1998 (2) and Roache et al. 1996 (5).

As detailed information on the effect of relative humidity on emission rates is not available, chamber tests are usually conducted under a single relative humidity (for example, 50 ± 5 % RH) for products that do not adsorb or generate significant amounts of moisture. Ideally, test specimens should be preconditioned under the test relative humidity condition before testing. However, this is usually not practical because exposing the test specimen to conditioned air also means emitting VOCs before the test is actually started. As a result, test products are usually wrapped or sealed in their original package materials/containers for temperature conditioning only before testing.

For moisture-adsorbing products (for example, fresh furniture materials) or moisture-generating products (for example, printers, liquid chemical products), a larger variation of relative humidity may be allowed in the chamber. Similar to the temperature variation in the chamber when testing a heat-generating product (see section 6.3.2.1), the moisture variation in the chamber when testing moisture-adsorbing or moisture-generating products also depends on the chamber operation. Specific chamber operating procedure and acceptable variability of relative humidity in the chamber should be established in a product-specific test protocol based on the test objectives.

6.3.2.3 Air Velocity and Turbulence—Air velocity and turbulence affect the evaporative mass transfer from both solid and liquid sources. For “wet” materials such as paints, stains, and varnishes, whose initial emission period is primarily controlled by evaporative mass transfer, increasing the air velocity and turbulence will lead to an increase in emission rates of VOCs. The effect becomes smaller as the materials become drier according to Roache et al. 1996 (5) and Zhang et al. 1996a (6). For dry materials such as carpets, wood-based products, and polyvinyl chloride (PVC) floorings, air velocity and turbulence affect emission rates only within the first 5 to 10 h of being exposed to the ambient air. After that, the effect becomes insignificant because the emissions will be controlled by internal diffusion, according to Awad 1999 (7), Yang 1999 (8), Wolkoff et al. 1996 (9), Little et al. 1994 (10), and Roache et al. 1998 (5).

In office and residential buildings, the magnitude of air velocities over material surfaces is typically in the range of 0 to 0.25 m/s according to Mathews et al. 1987 (11) and Zhang et al. 1995 (12). Turbulence kinetic energy is typically in the range of 0 to 0.01 (m/s)². In full-scale chambers, these air velocity and turbulence levels can be simulated if the testing purpose is to simulate a real room airflow condition. Because the actual air velocity and turbulence levels will be different from location to location in the chamber, multi-point measurements should be taken near the surfaces (for example, 1.0 cm from the surface) of test specimens to verify that the desired air velocity and turbulence levels are achieved. This is especially important for testing convective-controlled emission sources such as paints and wood stains. For internal diffusion-controlled emission sources such as carpets and engineered wood products, precise controls of the air velocity and turbulence over the surfaces of test specimens are not required

unless the emission rates during the first 5-10 h are of interest. For internal diffusion-controlled emission sources a general specification on air velocity (for example, in the range of 0.05 to 0.25 m/s) is usually sufficient.

6.3.2.4 VOC Concentrations in Air, Air Change Rate, and Loading Ratio—For an emitting material, the VOC concentration at the material surface is higher than that in the surrounding air. A higher VOC concentration in the air will lead to a lower concentration gradient between the material surface and the surrounding air, and hence a lower convective mass transfer rate from the surface to the air. The emission rate decreases as the VOC concentration in the chamber increases (for example, during the initial emission period of “wet” materials).

VOC concentrations in a chamber/space are dependent on the air change rate (ventilation rate) and/or material loading ratio for a given emission source. A high air change rate or a low material loading ratio will result in a low concentration in the chamber or space, and hence increase the emission rates. In addition, increasing the air change rate can also result in an increase in velocity and turbulence levels over the emitting surfaces, and hence the convective mass transfer coefficient.

Chamber tests can be conducted to simulate the impact of outdoor/clean air supply on room VOC concentrations. In office and residential buildings, outdoor air change rates may range from 0.05 to 1.5 air changes per hour [ASHRAE 1997a (13), ASHRAE 1997b (14), and Reardon and Zhang 1995 (15)]. ASHRAE Standard 62-1999 (16) specifies the outdoor air flow requirements for achieving acceptable IAQ. Additional recirculated air is required to meet the heating or cooling requirements for the space. If the purpose of a chamber test is to evaluate the impact of clean/outdoor air change rate on the VOC concentration levels, a small mixing fan (for example, those used for cooling a microcomputer) may be placed in the chamber to achieve adequate mixing for emission tests (see section 6.1). When this is done, however, airflow patterns in actual rooms are not simulated in the chamber.

6.4 The Role of Source Emission Models—Source emission models are used to describe the VOC emission rates (or emission factor) as a function of time, environmental conditions (temperature, humidity, and air velocity, etc.), and/or source (initial VOC content and composition, density, etc.) variables. These models are useful for designing full-scale experiments. For example, they can be used to select air sampling intervals and experimental conditions. They are also useful for analyzing emission test results from which the coefficients of selected models are estimated (see Section 11). Finally, the models can be used to extrapolate short-term emission test data to a longer term and from environmental chamber test conditions to field conditions. However, care should always be exercised in the extrapolation since any model has its limitations [CMEIAQ Final Report 3.1, Guo 1996 (17), Little et al., 1994 (10), and Zhang and Shaw 1997 (18)].

7. Facilities and Equipment

7.1 General Considerations for Chamber System Design and Construction—A complete full-scale chamber test facility consists of: a full-scale chamber and its heating, ventilation, and air-conditioning (HVAC) system for air supply and condi-

tioning, an air sampling and analysis system, and a data acquisition and recording system. The system should be housed in a clean and air-conditioned laboratory space. Following are the general design and construction considerations:

7.1.1 The chamber should be large enough to accommodate the products to be tested and allow the simulation of the product use in full-scale room conditions.

7.1.2 The chamber HVAC system must provide stable and accurate control of the airflow rate, temperature, differential pressure (pressure relative to the ambient pressure outside the chamber), and relative humidity within the chamber, and have the capacity to operate over the entire range of desired operating/testing conditions, considering the generation of heat and moisture from sources to be tested.

7.1.3 The chamber, air cleaning, and distribution components must be constructed of materials that minimize adsorption and emission of VOCs [for example, stainless steel, glass, polytetrafluoroethylene (PTFE)]. Fans and bearings must be designed to prevent intrusion of emissions from lubricants into the clean air system.

7.1.4 The chamber system should be airtight in order to minimize any air leakage between the inside and the outside of the chamber system.

7.1.5 The chamber system should be capable of providing sufficient mixing in the chamber for testing under the uniform VOC concentration assumption. If the chamber is intended to simulate airflow patterns, air distribution, air velocity, and turbulence levels that are typically found in real ventilated rooms, in addition to having the capability to accurately determine the emissions from indoor products, the chamber should be designed to accommodate both types of studies.

7.1.6 The chamber system should be able to provide on-line monitoring of the test conditions including airflow rates (clean and recirculated air), air temperature, relative humidity, and differential pressure inside the chamber and in the ventilation ducts. For example, a data acquisition system may be set up to monitor these conditions every minute. (Note that the reading frequency required for achieving good control accuracy may be much smaller, but will depend on the chamber system.) This will facilitate the detection of any malfunction of the system and help diagnose problems.

7.1.7 The chamber system should have adequate sampling ports for taking air samples both within the chamber and in the ventilation ducts.

7.1.8 All components of the chamber system (such as ducts, fans, cooling/heating coils) should be thoroughly cleaned before they are installed. Effort should also be made to avoid contamination during the construction period.

7.1.9 The chamber system and all components should be easily accessible for cleaning and maintenance.

7.2 The Full-scale Chamber:

7.2.1 Construction Material—Materials such as stainless steel, glass, aluminum, and PTFE coating are acceptable for the construction of the interior surfaces of the chamber, with stainless steel being the most common choice. Type 304 or 316 stainless steel with No. 4 finishing (a general purpose polished finish that finds wide applications in restaurant, dairy, food processing, medical, and chemical equipment as well as

various architectural products) may be used as the interior wall and floor surface. For example, 11 gage stainless steel panels may be used for the floor, and 14 gage used for the ceiling and walls. Sections can be fastened together by continuous welding at the joints of two panels and by tack welding to their supporting frame. Some discoloration may be observed in the vicinity of the welded lines due to the heat and oxidation in the welding process. The interior welded joints may be cleaned by wire brushing or mechanical grinding. If a highly polished surface finish is desired, matte-finish stainless steel sheets should be used since they can be more easily polished mechanically after construction to a semi-mirror finish (equivalent to the sterile finish used in hospitals). Ideally, it is desirable to electro-polish the surface to minimize the sink effect on the surfaces, but this is generally not practical because of the size of the chamber.

7.2.2 Chamber Door—The chamber door must be large enough to accommodate the largest material/product components to be tested. The seals between the door and chamber surfaces must be made of non-emitting and non-adsorbing materials (such as PTFE) and be adequate to maintain chamber leak rates at or below acceptable levels. PTFE gaskets and door clamps are usually used. If the door opens to the inside and the chamber will operate under a positive pressure relative to the outside of the chamber, the positive pressure in the chamber will improve the tightness of the door during chamber operation. If the door opens to the outside and the chamber is operated under a positive pressure, at least two clamps on each

side of the doorframe are usually necessary to ensure proper airtightness. In either case, the door should be operable from inside and outside the chamber for safety purposes. For experiments in which a technician will enter and exit the chamber (painting, etc.), it is desirable to have a small entry chamber with its own airtight door.

7.2.3 Lighting and Observation Windows—Lights may be installed above ceiling glass panels sealed with PTFE gaskets. PTFE-gasket-sealed observation windows may be installed on walls or the chamber door.

7.2.4 Insulation—The floor, ceiling, walls, and door of the chamber should be well insulated to minimize the influence of temperature fluctuation outside the chamber on the air temperature in the chamber.

7.2.5 Air Sampling Ports—Sampling ports should be installed at desired locations depending on the test purpose (for example, at the mid-height of walls). Stainless steel feed-through connectors with sealing caps may be used for this purpose. The length of the sampling line between the sampling device (for example, adsorbent tube) and the sampling location should be minimized in order to reduce the effect of VOC adsorption/desorption in the sampling line on the measurements.

7.3 The HVAC System for the Full-scale Chamber:

7.3.1 System Design—Different approaches may be used to supply controlled and conditioned airflow to the chamber. Figs. 1 and 2 show two different example systems. Depending on the purpose of testing, System 1 (Fig. 1) may operate in several

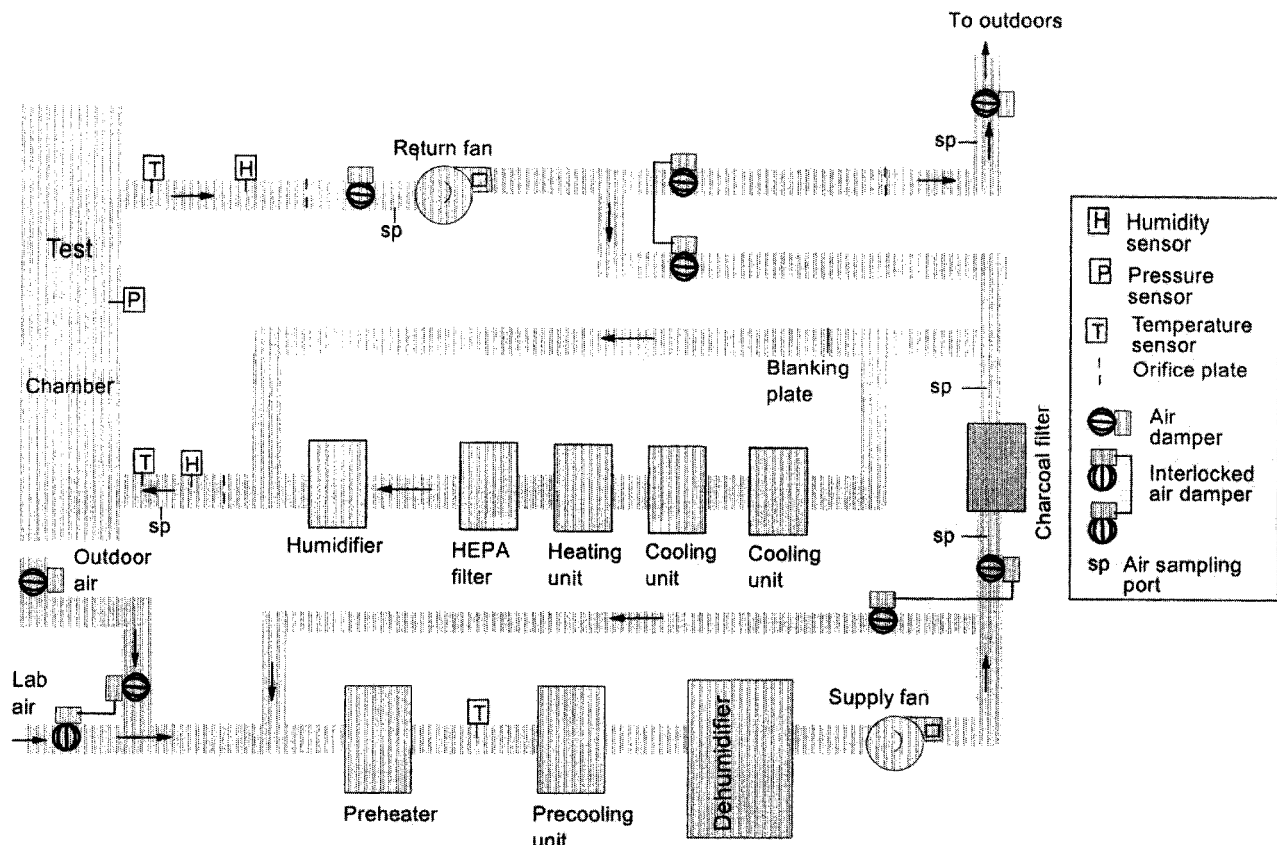

FIG. 1 Schematic of a Full-Scale Chamber System—Example 1 (EPA and NRC Chambers)

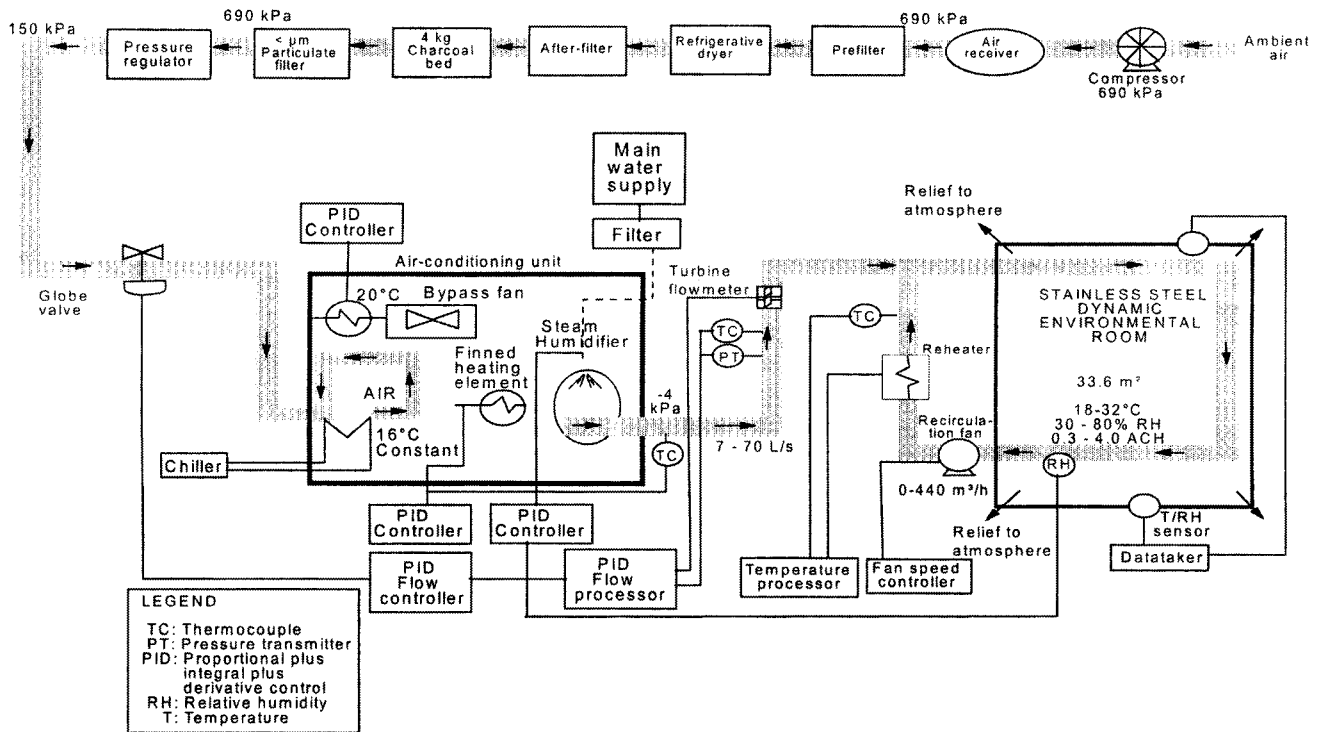

FIG. 2 Schematic of a Full-Scale Chamber System—Example 2 (OCSIRO Chamber)

modes: (1) full exhaust (FE) mode, in which all the supply air is exhausted with no air recirculated back to the chamber; (2) recirculation (RC) mode, in which part or all of the air from the chamber is recirculated back to the chamber; and (3) by-pass (BP) mode, in which part or all the air from the chamber is recirculated back to the chamber, bypassing the heating and cooling coils and humidifier. The BP mode may be used to determine if the HVAC components have significant adsorption/desorption effects for the VOCs measured. System 2 (Fig. 2) uses a completely different design for air supply, conditioning, and handling of air to the chamber. Air supply is from a compressor at 690 kPa, regulated to 150 kPa before reaching a flow-regulating valve that is linked via process controllers to a turbine flowmeter. Chamber pressure can be at 0-250 Pa above the ambient pressure in the laboratory space, and requires no extraction fan for operation. An air-conditioning plant operates between the flow regulating valve and the meter, conditioning only the supply air. Air enters the chamber along a central, perforated duct at ceiling level. Two similar ducts at floor level are connected to a supply duct via a fan so that chamber air can be recirculated. Extra heater and chiller components are located in the recirculation duct. The clean supply air is forced from the chamber under positive pressure via six exhaust ports in the chamber walls. This chamber can operate under the FE and RC modes described above, but without humidification of recirculated air.

7.3.2 Air Preconditioning—The air supplied to the system may come either directly from outdoors or from the laboratory space. The supply air must be preconditioned to avoid contamination of the chamber system and to allow the chamber system to operate at all designed temperature and humidity conditions. For example, in System 1 (Fig. 1), preconditioning

is accomplished by passing the air through a particulate filter, an electric preheater, a chilled water cooling unit, and a desiccant dehumidifier. A single-speed fan is used to circulate the air in the preconditioning loop. This preconditioning loop allows the system to operate at -40 to 30 °C outdoor air temperature and up to 95 % relative humidity. The preconditioning equipment should be sized to condition the air to the temperature and humidity ranges that can be handled by the conditioning components downstream in the recirculation loop to achieve the required control accuracy. In example System 2, air delivered from the compressor is passed through two oil-coalescing filters and a refrigerative dryer, and then improved by purification.

7.3.3 Air Purification—The supply air should be cleaned to satisfy the criteria of clean air (see section 3.2.2). This can be accomplished by passing the air through a catalytic oxidation system, activated carbon filters or packed beds, and a high-efficiency particulate air (HEPA) filter. These filters or chemical adsorption beds should have sufficient capacity and be easily accessible for replacement.

7.3.4 Heating, Cooling, and Humidification—The supply air should be further conditioned to achieve the required temperature and humidity control. This may be achieved by passing air through cooling/heating coils and a steam or other humidifier. All the components which are exposed to the supply air stream should be made of inert materials such as stainless steel or tin-plated copper. PTFE gaskets must be used to seal the various joints (for example, between air duct sections, between the cooling/heating component and ducts). The water supplied to the humidifier must be purified and deionized.

7.3.5 Control of System Operation—The operation of the chamber system may be controlled by a stand-alone DDC (direct digital control) controller or a dedicated computer. The set points for airflow rates, temperature, and relative humidity can be set by a microcomputer, which also monitors, displays, and records the operation conditions. The sensor reading frequency should be at least once every second, and the control system should be able to make the control adjustment within 1 min to achieve continuous control. One minute average of the 1 s readings may be recorded every minute. In System 1 (Fig. 1), airflow rates are measured by using orifice plates at the outdoor air supply duct, the preconditioning loop, immediately before the activated carbon adsorber, immediately before and after the chamber, and the exhaust duct. By controlling the positions of the interlocked air dampers at the exhaust and recirculation ducts, the exhaust airflow rate (and therefore the clean air supply flow rate) can be controlled. The total supply airflow rate is controlled by adjusting the position of the air damper upstream of the return fan (Fig. 1). The chamber pressure is controlled by the air damper installed upstream of the activated charcoal filter. These controls are accomplished by PID (proportional integral differential) control algorithms programmed in the DDC or the dedicated computer. In example System 2, temperature, humidity, and supply air flow are controlled by PID-programmable process controllers in all processes except recirculation flow, which is controlled by a fan speed control module (calibrated in-situ). The temperature, humidity, and supply airflow conditions achieved within the chamber are monitored by dual sensors in the chamber and the output from the turbine flowmeter, all connected to a data logger. Chamber pressure is adjusted manually within the 0-250 Pa above the ambient pressure in the laboratory space by opening extra vents in the chamber walls. Recommendations on control accuracy are described in section 8.3.

7.3.6 Air Distribution in the Chamber—To achieve good air mixing in the chamber, air should be introduced through air diffusers that create air jets (for example, ceiling radial square diffusers like those used in cold air distribution systems [Kirkpatrick and Elleson 1996 (19)]), or introduced through tube(s) with small perforated holes that distribute air evenly across the chamber. The tubes are usually located at the floor or ceiling level. Air is usually exhausted at or close to the ceiling or floor level. If the purpose is to study the spatial distribution of VOC concentrations in ventilated spaces, stainless steel diffuser(s) should be made to represent actual air diffusers that produce realistic airflow distributions.

7.4 Sample Collection and Analysis:

7.4.1 General Considerations—There are many ways to collect, detect, and quantify VOCs emitted from products. Every approach has its applications and limitations. Selection of the appropriate sampling and analysis strategies often depends upon the goals of the testing and resources available as well as the nature of the source emissions. It is often necessary to tailor sampling strategies to test conditions and to analytes of interest and/or employ several sampling strategies in order to characterize emissions from a particular source and test condition. General considerations that are generic to source characterization using large chambers are presented in this

practice [see Fortmann et al. 1995 (20) for a more detailed discussion]. Detailed considerations specific to individual sources are beyond the scope of this document. CMEIAQ Final Report 1.1 describes detailed considerations in sampling and analysis for testing VOC emissions from building materials.

Many of the procedures and equipment items utilized for characterization of indoor air source emissions are adapted from methods developed for ambient air sampling and analysis. The general applicability of a particular method for source characterization will depend upon the nature of the source, test conditions, and limitations of the sampling and analysis methods. For example, a broad range of VOC emissions may be collected on sorbent media. Analytes are typically thermally desorbed from the sampling media, concentrated on a secondary trap, then flash-desorbed in an inert gas flow to the column of a gas chromatograph (GC) for separation and subsequent detection and quantitation. Accurate quantitation of chamber emissions depends upon collection efficiency of the sampling system, stability of analytes during storage, transfer efficiency of the concentrator system, separation efficiency of the column, and sensitivity and range of the detection system. Such a system may be optimized for accurate determination of a broad range of non-polar VOCs. Optimization of the system for a particular polar, oxygenated, or reactive species may reduce or preclude recovery of other analytes.

The amount of emissions in a sample may also influence system performance. Sample collection and concentration systems optimized for ambient sampling and analysis may experience incomplete desorption and carryover when used to determine high concentrations that are sometimes encountered in chamber tests (for example, during application and drying phases of paints and coatings). Thus, when embarking upon characterization of a particular source, it is often necessary to conduct pilot tests to evaluate sampling and analysis protocols, and it is often necessary to generate relevant airborne concentrations of target analytes in order to optimize performance and demonstrate the efficacy of sampling and analysis systems. Therefore, a standards generation system that includes a clean air supply, source generators such as diffusion or permeation systems, as well as air temperature, relative humidity, flow control, dilution, mixing, and sampling manifold systems are essential components of a source characterization laboratory.

7.4.2 Selection of Sampling and Analysis Strategy—The following approach may be used to develop a sampling and analysis strategy for a particular source. The first step is to gather information about the possible types and ranges of emissions from the test material. Examine the emission data and test methods employed to determine if exploratory sampling and/or analysis strategies are required to identify compounds that may not have been reported due to the methodology used. The next step may be to conduct scoping tests to evaluate the adequacy of sampling and analysis methods. For products where the chemical composition of the source is known or may be determined by extraction and analysis, it is often possible to implement a mass balance approach to emissions characterization. This approach provides feedback regarding adequacy of emissions sampling and analysis methods, fundamental information about the product that may be

central to understanding factors controlling emission rates, and understanding chemical reactions that result in emissions of compounds not observed in the source.

7.4.3 Selection of Sampling Methods—VOC emissions from sources that impact the IAQ include very volatile, volatile, semi-volatile, polar, non-polar, oxygenated, and other species of organic compounds. Sampling systems include syringes, sampling loops, sorbent traps, sorbent tubes, cryogenic traps, whole air canisters, and other devices that collect and concentrate analytes of interest. The choice of sampling systems depends upon the nature and concentration of the analytes as well as testing goals. Guidance on selection of sampling systems is provided in Test Methods D 5197, D 5466, Practice D 6196, and Guide D 6345. Traps to remove particles or reactive compounds such as ozone may be required upstream of the adsorbent. Whenever a sampling line, probe, or trap is placed upstream of the sample collection device, it may be necessary to demonstrate quantitative recovery of analytes.

There are several methods that are generally applicable to the collection and analysis of VOC emissions from products in chamber tests. These methods include: (1) online sampling without concentration, (2) online sampling with concentration, (3) whole air sampling, and (4) collection on sorbent media. The merits and limitations of each approach are briefly discussed.

7.4.3.1 Online Sampling Without Concentration—Online sampling is usually accomplished by means of automated systems consisting of a GC configured with a gas sampling valve, actuator, sample loops, and detector. Typically, air is pulled from the chamber through transfer tubing and the sample loop via a vacuum pump and flow controller. Rotation of the sample valve allows injection of the contents of the loop onto the column of the GC by the carrier gas flow and places the second loop in line with the vacuum pump and sampling lines. This system is efficient when concentrations of emissions are within the method quantitation range and losses to sampling system components do not affect the transfer of analytes from the chamber air to the GC column. Sampling lines should be of minimal length and made of inert materials. Control of temperature may be required in all parts of the system (sampling lines, manifolds, valves, loops, transfer tubing) to prevent loss or carryover, depending on the compounds to be measured.

7.4.3.2 Online Sampling With Concentration—Due to the low concentrations of VOCs often encountered in emissions testing, it is often necessary to concentrate analytes from the air stream. The purpose of the concentration step is two-fold: (1) to lower the method detection limits, and (2) to collect the analytes but pass water vapor so as to reduce potential interference of water vapor on performance of the GC column and detector. For example, an online concentration system may have two VOC traps. The sample air is pulled through one trap during the desorption/analysis phase of the other trap. Each trap may contain a single adsorbent or combination of materials. The range of analytes that can be collected and recovered from the traps will depend upon the composition of the traps and the efficiency of the transfer of analytes from the traps to the GC. Applicability of the online sampling method depends

on the required analysis cycle time and the range of analytes that can be collected by the traps and transferred to the GC column without loss or carryover.

7.4.3.3 Whole Air Samples—Whole air samples may be collected for subsequent off-line analysis using gas sampling syringes, bags, and lined or passivated stainless steel canisters (see Test Method D 5466). Whole air samples permit sample storage and repeated analyses of the same sample. Gas sampling syringes have limited applicability to source testing due to their relatively low capacity, poor reproducibility, and potential for losses to syringe surfaces. Sampling bags provide an adequate volume of air for concentration, but analytes may diffuse through the bag or be lost to bag surfaces. Canister technology has been proven to be effective for many volatile compounds at ambient concentrations. Source testing often generates atmospheres with high concentrations of pollutants and generates pollutants of less volatility than those for which the canister technology has been developed and demonstrated. Therefore, as with any sampling system, it may be necessary to determine the appropriate application of the technique for a particular source.

7.4.3.4 Collection of VOCs on Sorbent Media—Collection on sorbent media is currently the most commonly used approach for indoor air source sampling. Sorbents are packed in glass or metal tubes, and known volumes of air are drawn through them. Analytes collected on these traps may be thermally desorbed to a concentrator unit or extracted with appropriate solvent for liquid injection. Thermal desorption is the most common approach due to ease of use and lower method detection limits.

The air sampling system should include a sorbent tube (or cartridge), an air sampling pump, and an airflow controller which can measure and control the airflow rate through the sampling system to within $\pm 5\%$ of a specified value. All system components between the chamber and the sorbent tube (or cartridge) should be constructed of chemically inert materials. The sorbent tube or cartridge should be connected directly to the sampling location at the chamber return/exhaust or inside the chamber by using a short (<0.4 m) stainless steel or PTFE tube/connector. The pump should be operated in suction mode downstream of the sorbent tube or cartridge to avoid contamination of air samples by the pump. Refer to Practice D 6196 and EPA TO17 for selection of appropriate sorbents.

7.4.3.5 Collection of Carbonyls on Sorbent Media—For selected low-molecular-weight aldehydes and ketones, compounds are collected and derivatized on cartridges containing silica gel coated with 2,4-dinitrophenylhydrazine (DNPH) (Test Method D 5197). The derivatized compounds are solvent-extracted and determined by high-performance liquid chromatography (HPLC) with ultraviolet (UV) or photo-diode array detection.

7.4.4 Selection of Sampling Methods and Protocols—The following are important factors to consider in the selection of sampling methods and protocols: (1) compounds to be determined, (2) expected concentrations of specific compounds during the tests, (3) collection efficiency, (4) recovery efficiency, (5) amount of water vapor in the sample, (6) storage

stability, (7) linear range of the analytical system, (8) analytical method detection and quantitation limits, and (9) artifact formation during collection, thermal desorption, or transfer of the sample to the analytical system.

Sampling volumes and flow rates for sorbent traps used to collect VOCs are selected based upon method quantitation limits, breakthrough volumes of compounds of interest, acceptable pressure drop across the sampling traps, and time resolution required for calculation of emission rates from chamber concentration data. For a particular analyte: the sample volume should be equal to or less than the safe sampling volume (SSV, see Practice D 6196), the mass collected on the adsorbent trap should be equal to or greater than the method limit of quantitation (LOQ), the sampling flow rate should be below that which causes excessive pressure drop (see manufacturer's recommendations), and the sampling period should be of a duration that permits intended use of the data. The limit of quantitation is defined as the level above which quantitative results may be obtained with a specified degree of confidence (21, 22). A proper sampling volume should be determined through a prescreening analysis (section 11.1). Refer to Practice D 6196 and Guide D 6345 for more guidance on sorbent selections and air sampling.

7.4.5 Selection of Chemical Analysis Systems—The appropriate instrumentation for the determination of emissions from products and processes depends upon the nature of the emissions and testing goals.

7.4.5.1 VOC Chemical Analysis Systems—A gas chromatograph (GC) equipped with capillary column and flame ionization (FID) or mass spectral (MS) detector is commonly employed for identification and quantification of VOC emissions. Due to the complexity of emissions from many types of sources, a GC/MS system may be considered essential for identification of VOC emissions from most sources. A GC/FID system is often useful for quantification of emissions due to the sensitivity and broad linear dynamic range of the detector. Other GC detectors such as electron capture (ECD) or photoionization (PID) detector are useful for specific types of compounds. If VOCs are present at relatively high concentrations (~1 ppm), detection systems such as Fourier transform infrared (FTIR) or mass spectral detection with atmospheric pressure ionization interface (API/MS) may be useful for identification of compounds that do not pass through the GC columns to the detector.

7.4.5.2 Formaldehyde and Other Carbonyl Analysis Systems—Many carbonyl compounds may be collected on silica gel coated with DNPH and determined by liquid chromatography with UV or photo-diode array detectors (see Test Method D 5197). Other wet chemical colorimetric techniques are available for monitoring specific compounds such as formaldehyde.

7.4.5.3 Other Chemical Analysis Systems—Process equipment such as photocopiers, laser printers, and air cleaners may emit ozone and NO_x. Combustion sources such as cigarette smoke may emit SO_x as well. Standard source and ambient monitoring equipment and sampling protocols may be utilized or adapted to determine concentrations of these pollutants in chambers and chamber exhaust.

7.4.6 Quality Control and Quality Assurance—Due to the complexity of source emissions testing, careful planning is usually required to ensure meaningful data. A quality assurance plan identifies the critical data needed to meet testing goals and provides a framework for collecting data that will help ensure that the data are of sufficient quantity and quality to meet the goals of the testing program. Certain kinds of quality control data are necessary to assess the performance of sampling and analysis systems. These data include results of periodic flow rate checks of sampling systems, analysis of replicate samples, analysis of field and laboratory blanks, spiked field control samples, daily tuning criteria for MS systems, and results of daily mid-range calibration check samples. Guidance on development of quality assurance and quality control programs is available from several sources [for example, EPA QA/R-5 (23)].

8. Performance Evaluation

8.1 Background Concentration of the Chamber System:

8.1.1 The background concentration of the chamber system should have a mean value of less than 15 % of the lowest concentration to be measured in a test, and a standard deviation of less than 50 % of its mean value. As a general guideline for quality assurance, the background concentration of a full-scale chamber should satisfy the following criteria:

8.1.1.1 TVOC $\leq 10 \mu\text{g}/\text{m}^3$;

8.1.1.2 any individual compound to be measured $\leq 2.0 \mu\text{g}/\text{m}^3$;

8.1.1.3 particulate $\leq 100 \text{ particles}/\text{m}^3$ of 0.5 μm diameter or larger, which is the Class M2 clean room requirement for >0.5 μm diameter particles [ASHRAE 1997c (16)], and

8.1.1.4 ozone and other potentially reactive species (NO_x, SO_x, etc.) should be at or below their detectable levels (for example, each reactive compound $<10 \mu\text{g}/\text{m}^3$).

8.1.2 The background concentration of the chamber system should be checked with the chamber operating under the required test conditions (temperature, relative humidity, and airflow rates). Air samples should be taken from the exhaust air duct to represent the background contamination of the chamber system. The following procedure can be used for commissioning the chamber system immediately after the construction:

8.1.2.1 Clean the chamber by scrubbing its interior surfaces with a sponge mop and a solution of laboratory ionic detergent that contains phosphate as the water softener and rinsing several times with clean water, followed by a final rinse with filtered deionized water.

8.1.2.2 Operate the chamber system under maximum design temperature, minimum relative humidity, and maximum airflow rate in the full exhaust mode overnight to flush and dry the chamber system.

8.1.2.3 Operate the chamber system under the required test conditions (for example, 23 °C, 50 % RH, 0.5 ACH clean air change rate, and 5 ACH total air supply flow rate) for a period of time that is at least equivalent to 3 ACH of clean air (that is, 6 h at 0.5 ACH).

8.1.2.4 Take a minimum of two air samples per day over 5 days from the exhaust air duct.

8.1.2.5 Analyze the air samples using a GC/MS, GC/FID, or other appropriate analytical systems to detect, identify, and quantify the background concentrations (see section 7.4.5.1).

8.1.2.6 Calculate the mean and standard deviation of the background concentrations, and compare them against the requirements in section 8.1.1.

8.1.3 Check the chamber background concentration before each experiment. These measurements will establish a history of the chamber background concentration, and help better characterize the variations of the chamber background concentrations. They will also be very useful for identifying causes of chamber contamination in the future. Chamber background concentrations measured before each experiment should be subtracted from concentrations measured during tests in the data analysis (see section 11.1).

8.2 Airtightness:

8.2.1 Airtightness of the chamber system can be assessed by measuring the air-leakage rate through the chamber envelope and its HVAC recirculation loop under a specified chamber pressure (for example, 10 Pa). This air-leakage rate can be measured under a static condition (that is, when the chamber HVAC system is off) or a dynamic condition (in which the chamber is operating under 100 % recirculation mode). As a guideline for general quality assurance, the air-leakage rate should be less than 0.03 and 0.05 ACH at 10 Pa pressure difference between inside and outside the chamber under the static and dynamic operating conditions, respectively.

8.2.2 Several methods can be used to determine the air-leakage rate of the chamber system (suitably sealed at the supply and exhaust ducts) as follows:

8.2.2.1 *Pressurization Method*—The chamber and its HVAC recirculation loop is pressurized by supplying air into the chamber to maintain a constant pressure differential (for example, 10 Pa) between inside and outside the chamber. The supply airflow rate required to maintain the constant pressure difference is the air-leakage rate of the chamber system at the pressure differential between the inside and outside the chamber (that is, 10 Pa). Detailed procedures for the pressurization test can found in Test Method E 779. The laboratory compressed air line can be used to pressurize the chamber. As the laboratory pressure (that is, pressure outside the chamber) is much more stable than that outside the building, a 10 Pa pressure differential between inside and outside the chamber is usually sufficient to obtain accurate measurements.

8.2.2.2 *Tracer Gas Method*—A small amount of tracer gas [for example, sulfur hexafluoride (SF₆)] is introduced into the chamber and its HVAC recirculation loop. The concentration of the tracer gas is measured continuously. The absolute value of the slope of the concentration decay curve on a semi-log scale plot is the air change rate due to the air leakage in the chamber system. This method requires that the tracer gas in the chamber be well mixed, which can be achieved by running a mixing fan in the chamber (see Test Method E 741).

8.3 Control Accuracy and Precision:

8.3.1 The capability of the chamber system to control the airflow rates, temperature, relative humidity, and pressure in the chamber should be assessed for the range of operating conditions for which the chamber system is designed. For a

given operating condition, the control accuracy and precision of the chamber system can be evaluated by continuously monitoring the control parameters (that is, airflow rates, temperature, relative humidity, and pressure) over a period of time (a minimum of 24 h is recommended). The control accuracy (expressed as the bias) and precision can be calculated by Eq 2 and 3, respectively:

$$\Delta = X - X_s \quad (2)$$

$$\Gamma = \sqrt{\frac{1}{n-1} \sum_{i=1}^n [x(t_i) - X]^2} \quad (3)$$

where:

Δ = control accuracy, defined as the difference between the mean value of the control parameter and its set point,

X = mean value of the control parameter,

$$X = \frac{1}{n} \sum_{i=1}^n x(t_i)$$

X_s = set point of a control parameter (flow rate, temperature, relative humidity or pressure),

Γ = control precision defined as the standard deviation of the control parameter from its mean value,

n = number of data measured for the control parameter,

I = index, representing a data point,

$x(t_i)$ = value of the control parameter measured at time t_i , and

t_i = measurement time of data point i .

8.3.2 As a guideline for quality assurance, the control accuracy and precision of the chamber system should meet the criteria in Table 1 during an assessment test of at least 24 h with a minimum measurement frequency of four samples per hour (that is, a 15 min maximum sampling interval):

8.4 Air-Mixing in a Chamber:

8.4.1 Good air-mixing in a chamber is essential if concentrations measured at the return or exhaust duct are used to represent the average concentrations in the chamber. The tracer gas stepup can be used to assess the air-mixing conditions within the chamber. In the stepup method, a tracer gas (for example, SF₆) is injected through the clean air supply duct to maintain a constant concentration (for example, 200 to 300 ppb of SF₆) at the inlet. Immediately after the injection, the gas concentrations are measured continuously at the return or

TABLE 1 Recommended Control Accuracy^A and Precision^A in a 24-Hour Assessment Test

Parameter	Control Accuracy, Δ (expressed as bias)	Control Precision, Γ
Temperature, °C	±0.5	±0.5
Relative humidity, %	±2	±5
Chamber pressure ^B , Pa	±10 % of the set point or ±5 Pa, whichever is greater	±20 % of the set point or ±10 Pa, whichever is greater
Airflow rates ^C , L/s	±3 % of the set point	±5 % of the mean value

^A Defined as the standard deviations of the measured parameters.

^B Static chamber pressure referenced to the pressure outside the chamber.

^C Including clean airflow rate, total supply airflow rate, return airflow rate, and exhaust airflow rate. Tracer gas tests should also be conducted to determine the clean air change rate and demonstrate its consistency with the clean airflow rate measured at the clean air supply duct. Note that the above criteria are provided as a guide for evaluating the integrity of the chamber facility. Specific and possibly different criteria may be established in product-specific test protocols according to specific test purposes.

exhaust air duct. The mixing condition in the chamber can be assessed by comparing the measured gas concentration at the return or exhaust with the theoretical curve for the uniform concentration condition as described in section 8.4.2.

8.4.2 A mixing level (η) may be defined as:

$$\eta = \left(1 - \frac{\int_0^{t_n} |C_m(t) - C(t)| dt}{\int_0^{t_n} C(t) dt} \right) \times 100 \% \quad (4)$$

where:

- η = mixing level,
- t_n = nominal residence time of the clean air supply (equal to 60/N), min,
- $C_m(t)$ = measured SF₆ concentration, ppb,
- $C(t)$ = theoretical concentration at the return air under the uniform concentration condition, ppb [note that $C(t) = C_o (1 - e^{-Nt})$],
- C_o = tracer gas concentration in the chamber air supply, ppb,
- N = air change rate, air change per hour, 1/h; and
- t = time, min.

Note that only the measured concentrations from time zero to t_n are used in the above procedure, which makes the mixing level, η , more sensitive to the non-uniform concentration condition in the chamber. A mixing level of higher than 80 % may be considered satisfactory since the corresponding spatial non-uniformity (maximum concentration difference between the sampling locations inside the chamber and at the exhaust, divided by the average concentration between the measured locations) of the tracer gas concentration inside the chamber is estimated to be less than 5 % based on the experimental results of Zhang et al. 1996b (24). For sources with a constant emission rate, a 5 % non-uniformity in the chamber concentration is estimated to cause a maximum of 5 % error in the determination of the emission rate.

Other tracer gas test procedures such as the stepdown (decay) method may also be used for assessing the mixing condition in the chamber, but an equivalent mixing criterion should be established.

Also note that the foregoing tracer gas test procedure essentially measures how well the supply air is mixed with the chamber air. A chamber system that meets the above criteria is adequate for testing relatively stable emission sources such as most dry materials and the later emission period of “wet” materials. However, for testing the emission sources that have highly variable emission rates such as the initial emission period of “wet” materials, the time required for the VOCs to travel from the source to the exhaust may cause large concentration gradients in the chamber and thus cause significantly larger error in the determination of the emission rates. This problem may be more pronounced for point sources than distributed (or large surface) sources. In such cases, multipoint air sampling must be taken inside the chamber in addition to sampling at the chamber exhaust to verify whether the VOC concentrations measured at the chamber are suitable for representing the average concentrations in the chamber.

8.5 Air Distribution, Air Velocity, and Turbulence Levels in a Chamber:

8.5.1 The air distribution, air velocity, and turbulence levels in a chamber depend on the type of air distribution system used in the chamber. Using an air diffuser that has similar characteristics to a real commercial air diffuser (for example, a radial square or slot ceiling diffuser, a floor register) can generally provide the realistic airflow patterns and air velocity and turbulence levels found in typical office or residential rooms. Air velocity measurement in a chamber using perforated-duct diffusers also demonstrated that velocities typical of indoor spaces are achieved, but turbulence levels are unknown.

8.5.2 For a given air distribution system, the air velocity and turbulence levels can be characterized by measuring their values at different locations in the chamber. The maximum distance between adjacent measurement points is recommended to be 0.5 m and the points closest to a surface are recommended to be 0.01 m away from the surface. Low velocity thermal anemometers are generally suitable for these measurements. As a guideline for quality assurance, the average value of the measured air velocities should be in the range of 0 to 0.25 m/s, and the turbulence kinetic energy should be in the range of 0 to 0.01 (m/s)² for locations where test specimens may be placed unless for special test cases, where measurement of emission rates at higher air velocities (for example, close to air diffusers) is of interest.

8.5.3 The materials/products to be tested in the chamber may also affect the air flow pattern and the air velocity and turbulence levels. Therefore, it is necessary to verify the velocity and turbulence levels with the test specimen in the chamber for evaporative-controlled sources such as “wet” building materials whose emission rates are strongly affected by air velocity and turbulence above them.

8.6 Chamber Sink Effect:

8.6.1 The interior surfaces of the chamber and the HVAC recirculation loop (including the stainless ducts, and cooling and heating coils) may adsorb VOCs. This sink effect may affect the accuracy of emission testing results, needs to be evaluated and, if significant, be taken into account.

8.6.2 Ideally, the sink effect should be evaluated for the compounds to be measured and for the chamber operating conditions under which the emission tests are to be conducted. For quality assurance, the following example procedure can be used to evaluate the sink effect of the chamber system [Mason et al. 1997 (25), Mason et al. 1999 (26), and Zhang et al. 1999a (28)]:

8.6.2.1 Operate the chamber system to achieve a standard test condition (23 °C, 50 % RH), then turn off the chamber HVAC system or operate it under full-recirculation mode, depending on the system components to be included in the test. Take a baseline air sample and ensure that the background concentrations meet the requirement in section 8.1.1.

8.6.2.2 Inject a small amount of a non-adsorption tracer gas (for example, 14 mL of SF₆ for a 55 m³ chamber) into the chamber, and monitor its concentration over time (for example, by using a GC/ECD- or IR-based gas monitor).

8.6.2.3 Inject a vaporized mixture of VOCs to be tested (for example, ethylbenzene, decane, 1,2-dichlorobenzene, 1-octanol, and dodecane) into the center of the chamber. This can be done using an injector that is heated to 250 °C. A small

mixing fan may be located under the injection point to blow the mixture upward to distribute the vaporized mixture within the chamber. Alternatively, a small amount of the VOC mixture contained in a small dish can be placed in the chamber for evaporation under the normal temperature of 23 °C (in this case, sufficient time should be allowed for complete evaporation of all VOCs in the mixture) or at 250 °C if the dish is placed on an electrically heated plate. The resulting maximum concentrations in the chamber may be on the order of 1 to 10 mg/m³. Note that the mixing fan and the heating plate must be cleaned before use to avoid contaminating the chamber.

8.6.2.4 Take duplicate air samples to determine the initial VOC concentrations, $C_{initial}$, and measure the tracer gas concentration $C_{tr_initial}$. Leave the chamber under the static or full-recirculation condition for 18 h after the injection to allow the concentration to reach an equilibrium state (for some compounds that have a lower vapor pressure than dodecane, a longer time period may be required to reach equilibrium). Then take an air sample to determine the equilibrium concentrations, C_{eq} , of injected VOCs, and also measure the tracer gas concentration in the chamber, C_{tr_eq} .

8.6.2.5 Turn on the HVAC system and operate it at 0.5 ACH clean air, 23 °C, and 50 % RH. The time when the HVAC system is started is defined as time zero.

8.6.2.6 Take air samples from inside the chamber and the return or exhaust air duct of the chamber at appropriate time intervals from time zero for a minimum of 48 h, and determine the concentrations of the VOCs by using GC/FID, GC/MS, or other appropriate method. Also monitor the concentration decay of the tracer gas for verifying the chamber air change rate during the test.

8.6.2.7 Calculate the following parameters:

(1) Total sink ratio, r_{st} , is defined as the ratio between the mass adsorbed during the 18 h period and the total VOC mass in the chamber at the end of the 18 h adsorption period:

$$r_{st} = \frac{M_{st}}{M_t} = \frac{M_o - M_{leak} - M_{air}}{M_o - M_{leak}} = 1 - \frac{C_{eq}V}{M_o - M_{leak}} \quad (5)$$

where:

- r_{st} = total sink ratio,
- M_{st} = total VOC mass adsorbed by the chamber surfaces (sink) at the end of the adsorption period, mg,
- M_t = total VOC mass in the chamber ($M_{st} + M_{air}$) at the end of adsorption period, mg,
- M_o = VOC mass injected, mg,
- M_{leak} = VOC mass loss due to air leakage during the 18 h adsorption period, mg,
- M_{air} = VOC mass in the chamber air at equilibrium ($M_{air} = C_{eq}V$), mg,
- C_{eq} = the concentration at the end of the adsorption period (that is, the start of the desorption period), which is assumed to be the equilibrium concentration, mg/m³; and
- V = volume of the chamber system (including the air volume of the recirculation loop if the loop is included in the test), m³.

The loss of tracer gas can be attributed entirely to the air leakage, while the VOC concentration decay is due to both leakage and adsorption to the surface. Assuming that VOC

concentration decay follows the first-order decay equation, M_{leak} can be determined using the VOC and tracer gas concentrations measured at the start and end of the adsorption period (that is, $t = t_{eq} = 18$ h) as follows:

$$M_{leak} = N_{leak}V \int_0^{t_{eq}} C_{initial} e^{-k't} dt = VC_{initial} \frac{N_{leak}}{k'} (1 - e^{-k't_{eq}}) \quad (6)$$

where:

- $N_{leak} = 1/18 (\ln C_{tr_initial} - \ln C_{tr_eq})$ = the leakage rate in air changes per hour (h⁻¹), and
- $k' = 1/t_{eq} (\ln C_{initial} - \ln C_{eq})$ = the VOC concentration decay rate (h⁻¹).

(2) Non-recoverable sink ratio, r_{si} , defined as the ratio between the non-recoverable VOC mass and the total VOC mass in the chamber at equilibrium:

$$r_{si} = \frac{M_{si}}{M_t} = \frac{M_t - M_{exit}}{M_o - M_{leak}} = 1 - \frac{Q \int_0^{\infty} C(t) dt}{M_o - M_{leak}} \quad (7)$$

where:

- r_{si} = irreversible sink ratio (1- r_{si} is sometimes called mass recovery ratio, quantifying the mass recovered from the air exhausted from the chamber),
- M_{si} = VOC mass that is not re-emitted from the sink (that is, irreversible), mg,
- M_{exit} = VOC mass exhausted from the chamber during the desorption period, mg,
- Q = clean airflow rate (which is equal to the exhaust airflow rate), m³/h,
- $C(t)$ = concentration of exhausted air, mg/m³ (at $t=0$, $C=C_{eq}$), and
- t = elapsed time since the start of the desorption period (that is, $t=0$), h.

(3) Reversible sink ratio, r_{sr} , defined as the ratio of re-emitted VOC mass to the total VOC mass in the chamber at equilibrium (that is, at the start of the desorption period):

$$r_{sr} = \frac{M_{sr}}{M_t} = \frac{M_{exit} - M_{air}}{M_o - M_{leak}} = \frac{Q \int_0^{\infty} C(t) dt - VC_{eq}}{M_o - M_{leak}} \quad (8)$$

where:

- r_{sr} = reversible sink ratio, and
- M_{sr} = VOC mass re-emitted from the sink, mg.

Note that $r_{st} = r_{si} + r_{sr}$. In the actual experiments, the concentration in the chamber could be measured only for a limited period of time due to the detection limit of the VOC measurement instrument. The mass exhausted, M_{exit} , in Eq 7 and 8 can be calculated by:

$$M_{exit} = Q \sum_{i=1}^n 0.5 [C(t_i) + C(t_{i-1})] (t_i - t_{i-1}) \quad (9)$$

where:

- n = number of sampling points in the dynamic test period, and
- i = sampling time point, $i = 0, 1, 2, \dots, n$ [note that $C(t_0) = C(0) = C_{eq}$].

8.6.2.8 For a VOC of interest, the irreversible sink ratio, r_{si} , should be less than 0.1. Otherwise, the cause of the problem

should be identified (for example, unknown air leakage or condensation around cooling coil) and rectified. If the recirculation loop is acting as a strong irreversible sink for the VOC of interest, the chamber should be operated in the full-exhaust mode in the emission tests.

8.6.2.9 For a VOC of interest, the reversible sink ratio, r_{sr} , should be less than 0.1. Otherwise, the adsorption and desorption rate constants of the chamber system should be estimated using the procedure in section 8.6.3. These constants can be used to account for the sink effect in analyzing the emission test data (see section 11.3) if the sink effect has significant impact on the emission rates measured.

8.6.3 *Determination of the Adsorption and Desorption Constants*—The following first-order reversible sink model can be used to describe adsorption/desorption of indoor VOCs on chamber surfaces [Tichenor et al. 1991 (27); Zhang et al. 1999a (28)]:

$$s(t) = \frac{dm(t)}{dt} = k_a C(t) - k_d m(t) \quad (10)$$

where:

- s = sink rate, $\text{mg}/(\text{m}^2\text{h})$,
- $m(t)$ = mass in the sink per unit surface area, mg/m^2 ,
- k_a = adsorption rate constant, m/h ,
- $C(t)$ = concentration over the sink surface, mg/m^3 (at $t=0$, $C=C_{eq}$), and
- k_d = desorption rate constant, $1/\text{h}$.

The adsorption and desorption rate constants (k_a and k_d) are measures of how fast adsorption and desorption take place on the sink surface. The ratio between the adsorption and desorption rate constants is called the equilibrium constant, k_e , which is a measure of the reversible sink capacity of the surface. In expression,

$$k_e = \frac{k_a}{k_d} \quad (11)$$

At equilibrium (that is, at $t=0$), $s(t)=0$, $C(t)=C_{eq}$, and $m(t)=m_e$ (which is the re-emittable VOC mass adsorbed in the sink per unit surface area at equilibrium), it can be readily derived from Eq 10 and 11 that

$$k_e = \frac{m_e}{C_{eq}} = \frac{VM_{sr}}{A_s M_{air}} = \frac{r_{sr}}{L_s (1 - r_{si} - r_{sr})} \quad (12)$$

where:

- m_e = re-emittable VOC mass adsorbed in the sink per unit surface area at equilibrium ($m_e=M_{sr}/A_s$), mg/m^2 ,
- A_s = the total area of the sink surfaces in the chamber system, m^2 , and
- L_s = loading ratio of the sink surfaces (A_s/V), m^2/m^3 .

Theoretically, the sink surfaces of the chamber system should include all the interior surfaces of HVAC components (ducts, heating and cooling coils, HEPA filter, etc.) as well as the walls, ceiling, and floor of the chamber if the chamber system is operating under the recirculation mode (that is, RC mode). However, because it is difficult to quantify the surface areas of heating/cooling coils and HEPA filters, only the interior surfaces of the chamber, ducts, and housing boxes for cooling and heating coils may be included for calculating A_s in a standard test. This area may be referred to as the nominal sink surface area.

Assuming uniform concentration in the full-scale chamber, the concentration of a VOC in the chamber during the desorption period can be described by [Tichenor et al. 1991 (27); Zhang et al. 1999a (28)] as,

$$C(t) = \frac{C_{eq} [(N - r_2)e^{-r_1 t} - (N - r_1)e^{-r_2 t}]}{r_1 - r_2} \quad (13)$$

where:

$$r_{1,2} = \frac{(N + k_a L_s + \frac{k_a}{k_e}) \pm \left[\left(N + k_a L_s + \frac{k_a}{k_e} \right)^2 - 4N \frac{k_a}{k_e} \right]^{1/2}}{2}$$

To summarize, the procedure for calculating the adsorption, desorption, and equilibrium constants is:

- (1) Calculate r_{si} and r_{sr} by Eq 7 and 8, respectively,
- (2) Calculate k_e by Eq 12; and
- (3) Fit Eq 13 to the measured $C(t)$ data using the least square regression analysis to determine k_a (that is, only one parameter is determined by the regression).

NOTE 2—The understanding of the non-recoverable sink effect is very limited. Using stainless steel surfaces can generally limit the non-recoverable sink ratio to below 0.1 for VOCs most commonly emitted from materials and products found for indoor applications. However, for compounds that may have significant non-reversible sink effects (for example, due to degradation on the chamber surfaces), a different method or facility may be required for the emission testing [Jayjock et al. 1995 (29)]. The extent to which the reversible chamber sinks affect the emission tests also depends on the emission characteristics of the source. The impact of the reversible sink effect on the emission test results is most significant for “wet” coating materials which usually have high initial emission rates and fast initial decay rates of emissions. The impact for dry materials is usually minimal because of their low emission rates and slow decay rates. The impact of reversible sink effect on emission test results should be estimated for specific conditions (chamber volume, air change rate, specimen loading ratio, compounds to be measured, and emission rate profile) under which emission tests are conducted [Zhang et al. 1999b (30)]. The first-order reversible sink model described above may be used to account for the reversible sink effect if it is considered to be significant (see Section 11). Also note that a $\pm 10\%$ error in the measurement of VOC concentrations by using thermal desorption-GC/MS or GC/FID analysis is not uncommon. Duplicate or multi-samples are recommended in using the above test procedure to assess the sink strength of the chamber system.

8.7 *Evaluation of Overall Chamber Performance Using a Standard Source*—The overall performance of the chamber system can be assessed by using a standard source whose emission rate is measured independently from the chamber testing method. In the procedure described below, a pool of pure liquid VOC (for example, decane, dodecane) contained in a petri dish is used as a reference emission source. The reference source is placed in the test chamber and its weight loss due to evaporation/emission is measured by an electronic balance to determine the reference emission rate, $R_r(t)$. The environmental chamber is operated under a well-mixed air condition with a constant air temperature, relative humidity, and air change rate. The concentration of the VOC measured at the chamber exhaust (or a location in the chamber that is sufficiently far away from the reference source) is used to determine the emission rate, $R(t)$, as is typically done in environmental chamber testing (referred to as the chamber

method). The overall performance of the full-scale environmental chamber is quantified by the relative difference, $\delta(t)$, between $R(t)$ and $R_2(t)$ [Zhang et al. 1999b (30)]:

$$\delta(t) = \frac{R(t)}{R_r(t)} - 1 \quad (14)$$

8.7.1 Determination of Reference Emission Rates—The weight of the reference source, $w(t)$, is measured by an electronic balance with a resolution of at least 10 mg (a better resolution such as 1.0 mg is preferred if a low reference emission rate is to be measured). The weight data can be recorded automatically with an on-line personal computer (PC), a chart recorder, or manual readout. The size of the petri dish should be selected so that maximum concentration in the chamber is on the order of 1 to 10 mg/m³. The cross section area of the cylindrical petri dish is constant except near the bottom of the dish. As a result, a constant weight decay (and thus a constant emission rate of the source) is obtained under a constant ambient environmental condition until the liquid surface approaches the bottom of the dish. Two procedures may be used for generating the reference source:

Variable Source Procedure (VSP): The source is allowed to deplete completely in the chamber, and thus provides a variable reference emission rate when the liquid level reaches the bottom of the petri dish.

Constant Source Procedure (CSP): The petri dish is removed from the chamber about 18 h after the start of the test. A sufficient amount of the source is placed in the dish so that the liquid source surface will not reach the bottom of the dish before the source is removed. As a result, only a constant reference emission rate is generated.

In either procedure described above, the measured weight decay data, $w(t)$, can be represented by:

$$w(t) = \begin{cases} a + bt, & 0 \leq t \leq t_1 \\ a + bt + c(t-t_1)^2 + d(t-t_1)^3, & t_1 \leq t \leq t_n \end{cases} \quad (15)$$

where:

- $w(t)$ = weight of the compound in the petri dish, g,
- a, b, c, d = constants,
- t = time, h,
- t_1 = time at which the weight no longer decreases linearly with time, h, and
- t_n = time at which the measured weight data became zero.

Eq 15 is continuous to the first order derivative at $t=t_1$. For the variable source procedure (VSP), t_1 and the constants (a, b, c, d) are all determined by a least square regression curve fit to weight decay data. For the constant source procedure (CSP), t_1 is the elapsed time when the source is removed, and $c=d=0$.

The reference emission rate, $R_r(t)$ in mg/h, is then calculated by:

$$R_r(t) = -1000 \frac{dw(t)}{dt} = \begin{cases} -1000b, & 0 \leq t \leq t_1 \\ -1000[b + 2c(t-t_1) + 3d(t-t_1)^2], & t_1 \leq t \leq t_n \end{cases} \quad (16)$$

8.7.2 Measurements of the VOC Concentrations and Calculation of Emission Rates—The same method used for emission testing may be used for measuring the VOC concentrations. All measurement instruments must be properly calibrated before the tests.

Assuming uniform concentration in the chamber, the emission rate at time t_i can be calculated by:

$$R(t_i) = \frac{1}{2}V \left(\frac{C(t_i) - C(t_{i-1})}{t_i - t_{i-1}} + \frac{C(t_{i+1}) - C(t_i)}{t_{i+1} - t_i} \right) + QC(t_i) \quad (17)$$

where:

V = volume of the chamber, m³,

C = concentration, mg/m³,

i = index representing time point i , and

Q = clean airflow rate supplied to the chamber, m³/h.

NOTE 3—Sufficient data points are needed in using Eq 17. It also requires that measured $C(t_i)$ be sufficiently smooth (see note in section 11.2.2).

8.7.3 Experimental Procedure—The following procedure may be used:

8.7.3.1 Precondition the chamber to the test condition. The background concentrations should be less than 0.002 mg/m³ and 0.05 mg/m³ for decane and TVOCs, respectively.

8.7.3.2 Start the data acquisition system to monitor the weight decay and VOC concentrations.

8.7.3.3 Inject the liquid source into the petri dish.

8.7.3.4 Monitor the source weight and VOC concentrations throughout the tests.

8.7.3.5 Remove the source approximately 18 h after the start of injection (for the constant source procedure only). Stop the chamber HVAC system and restart it immediately before and after removing the source. The total time for removing the source must be less than 2 min so that the effect on the measurement is minimal.

8.7.3.6 Continue to monitor the source weight and VOC concentrations until both are undetectable or less than twice the background concentration. Each test lasts a minimum of 48 h.

8.7.4 The forgoing procedure can be used to identify both systematic and random errors. Plot of $\delta(t)$ over t can be used to determine where the difference between the measured and reference emission rates is largest. As quality assurance, the time average of $\delta(t)$ should be within $\pm 15\%$ and the standard deviation of $\delta(t)$ should be within $\pm 10\%$. Otherwise, causes for any large error should be identified. Note that the error can be due to the uncertainty in the measurement of VOC concentrations as well as to the construction and operation of the chamber system.

9. Collection and Preparation of the Test Specimen

9.1 Material Collection, Packaging, Transportation, and Storage—A standard procedure should be established for the collection, packaging, transportation, and storage of the materials/products to be tested. The procedure is likely to differ depending on the type of material/product to be tested. The key is to avoid contamination of the test material/product, while keeping the procedure practical. Examples of procedures for material collection, packaging, transportation, and storage may be found in product-specific test protocols such as Test Method E 1333.

9.2 Preconditioning—A test specimen (material/product) should be preconditioned before testing in the full-scale chamber to improve test repeatability. It is recommended that the test specimen be kept within its original packaging material in a space that has the same temperature for a minimum of 48

h for temperature equalization. The relative humidity of the preconditioning room should be maintained at the same value as the test condition (for example, 50 % RH), and the room should be supplied with clean air to prevent contamination of the test specimen. Detailed preconditioning requirements and procedures should be established in the product-specific test protocols. The specifications and duration of preconditioning procedures will be dependent upon the objectives of the test. They may also be influenced by practical considerations; for example, the need to minimize the time in which test specimens monopolize the test chamber. If the objective is to determine the emissions to which occupants will be exposed, it might be desirable to perform a test after the material has been preconditioned for some period; for example, 2 weeks.

10. Test Procedure

10.1 *Screening Analysis Procedure*—A screening analysis is usually needed to identify VOCs emitted by the product, set proper operating conditions for the analytical instruments such as GC/MS, GC/FID, and/or HPLC systems, select target VOCs, and determine a proper air sampling volume for subsequent dynamic full-scale environmental chamber tests. For materials/products from which a small specimen can be collected to represent the entire piece of materials/products, the prescreening analysis may be conducted using a small chamber (Guide D 5116). For full-scale materials/products (for example, a work station system), the screening analysis may be conducted using the full-scale environmental chamber with the following procedure:

10.1.1 Follow the environmental chamber testing procedure in sections 10.2.1-10.2.5 to prepare the chamber air and sorbent tubes or cartridges for sampling.

10.1.2 Take multiple air samples using sorbent tubes with different air sampling volumes ranging from low to high (for example, 1, 3, 5, 7, and 10 L). This should be done after the environmental test chamber has been supplied with clean air for at least 3 air changes at the standard air flow rate (that is, 6 h if the air change rate is 0.5 h⁻¹) so that approximately 95 % of the background VOCs introduced during loading the specimen have been removed.

10.1.3 Analyze the sorbent tubes (or cartridges) by using the GC (or HPLC) (preferably in the order of low to high volume samples to avoid possible overloading of the analytical system). Different GC operating parameters (columns and temperature program) or HPLC operating parameters may be tested to obtain a good separation of emitted VOCs. The results will be used to determine a proper set of GC or HPLC operating parameters for subsequent environmental chamber testing. Additional sorbent tube or cartridge samples may be taken from the environmental test chamber if necessary.

10.1.4 Identify the VOCs emitted by the test specimen, based on the results of GC or HPLC analysis. The selection of major VOCs for subsequent environmental chamber testing depends on the objective of the testing. For each selected VOC, identification should be confirmed by spiking with a corresponding VOC standard.

10.1.5 Determine proper air sampling volume for subsequent environmental chamber testing so that the amount of VOC mass measured is at least 3 times higher than the

detection limit of the GC/MS and/or GC/FID system(s). The sampling volume should also be adjusted in the subsequent dynamic environmental chamber test (section 10.2) according to the trend of the emission decay rate of the source.

10.2 *Dynamic Environmental Chamber Testing Procedure*—A specific test procedure should be established for product-specific test protocols. This section provides a general testing procedure to be used as a guideline:

10.2.1 *Purging*—The environmental test chamber should be operated at the selected environmental test condition (for example, 23 °C, 50 % RH, and 0.5 ACH clean air supply) for a minimum of 3 air changes. This allows the removal of at least 95 % of the background contamination that might be introduced when the door of the chamber was opened.

10.2.2 *Checking of Background Concentration*—Sample at the return, the exhaust, or inside the chamber using a sorbent tube or cartridge to check the background concentration. The background VOC concentrations should meet the criteria specified in section 8.1.1. Otherwise, the testing system should be checked for the cause of the excessive background contamination and steps taken to eliminate this contamination (for example, using the procedure in section 8.1.3). The acceptable background concentration is denoted as C_{bk} , and will be used in the data analysis in section 11.1.

10.2.3 Prepare the test specimen according to the procedure in a product-specific test protocol or a predefined procedure, depending on the objective of the testing.

10.2.4 *Loading of Test Specimen*—Place/install the test specimen system in the chamber according to the requirements of the specific test. Record the time when the chamber door is closed after loading the test specimen. (This time may be defined as time zero for the environmental chamber testing.) Alternatively, a period of time following the installation of the test specimen may be used to conduct the screening analysis, or preconditioning the test specimen. The time at the end of the prescreening analysis or preconditioning period can then be defined as time zero for the tests. In any case, time zero should be well defined in a product-specific test protocol.

NOTE 4—Maintain positive pressure in the chamber during sample loading to prevent intrusion of air from the laboratory. Systems equipped with automatic pressure control may require special precautions when the door is opened. Note that opening the chamber door to load the test specimen with the HVAC system off may introduce VOCs from the laboratory space into the chamber. An air sample should be taken in the laboratory space to verify whether this will affect the test results significantly. To reduce such an effect, the HVAC system may be operated at a higher clean air supply flow rate (for example, 2 instead of 0.5 ACH) with the return air damper shut and the return fan off. As a result, the clean air is supplied to the chamber and exits through the open door. However, a specific operating sequence should be developed for a given chamber system. An example procedure for System 1 (Fig. 1), is: (1) turn off the HVAC system; (2) shut the return and recirculation dampers, and fix the position of the supply air damper (that is, disable the PID control for the chamber pressure); (3) open the door and turn on only the clean air supply fan; (4) load the test specimen and close the door; and (5) operate the HVAC under the specified test condition. (Note: A separate control sequence can be set up for running the HVAC system during the period of loading the test specimen.) Example System 2 (Fig. 2) can also operate at a higher air change rate by directly increasing the supply airflow rate since no feedback control is used in controlling the chamber pressure.

10.2.5 *Sampling*—The following example procedure is recommended:

10.2.5.1 Clean and condition the sorbent tubes before air sampling (or prepare cartridges or other sampling devices).

10.2.5.2 Purge the sampling port/line for 5 min prior to the collection of air samples.

10.2.5.3 Take air samples at predefined time intervals to determine the concentrations of TVOCs and compounds of interest at the chamber exhaust or return air ducts, and at pre-selected locations in the chamber, depending on the test objectives.

NOTE 5—Proper sampling intervals and periods should be selected according to the objectives of the specific testing. Generally more samples should be taken when the emission rate changes relatively fast and fewer samples are needed if the emission rate is constant or only changes slowly. The period of loading/installing the test specimen can result in significant variations in the test results of the initial period. If the test objective is to determine the long-term emission rate based on the concentrations measured at the return or exhaust air ducts, it is recommended that actual sampling start after a minimum of 3 air changes of clean air supply in order to minimize the effect of the loading/installation period on the test results.

10.2.5.4 *Unloading and Background Verification*—Ideally, equilibrium sorption coefficients are determined prior to testing and sorption effects can be incorporated into the data analysis. Alternatively, remove the test specimen after the last air sample has been taken and purge the chamber for 3 air changes. Sample the air from the chamber exhaust. If the concentration of the selected VOCs exceeds 15 % of the minimum concentration measured during the test, the problem should be identified and corrected, and the test should be repeated.

NOTE 6—The background concentration of the supply air should be verified frequently during the entire test period.

11. Data Analysis and Interpretation

11.1 *Calculation of the Concentrations*—The concentrations of the VOCs are calculated by:

$$C(t_i) = \frac{m(t_i)}{V_s} - C_{bk} \quad (18)$$

where:

$C(t_i)$ = concentration of the compound at time t_i , mg/m³,
 $m(t_i)$ = mass amount measured by a GC/FID, GC/MS, HPLC, or other analytical system, mg; note that, if a split ratio less than 1 is used in the analysis (for example, in a thermal desorber—GC/MS analysis), $m(t_i)$ should be the detected mass amount divided by the split ratio

t_i = elapsed time from time zero, h
 V_s = sampling volume (equal to the air sampling airflow rate times the air sampling period for sorbent or cartridge samples), m³; and

C_{bk} = background concentration of the compound in the chamber measured before the test, mg/m³.

The concentrations measured in the occupied zone within the chamber can be used directly to assess the impact of the materials/products tested on the concentration levels in buildings with similar material/product loading ratio and air change rate.

11.2 *Direct Calculation of Emission Rate*—(Guide D 5116)

11.2.1 For sources with a constant or near-constant emission rate, the emission rate can be calculated by:

$$R(t_i) = QC(t_i) \quad (19)$$

where:

$R(t_i)$ = emission rate at time t_i , mg/h, and

Q = clean air supply flow rate, m³/h.

The above calculation method should not be used until the chamber concentrations reach steady-state. This means that $C(t_i)$ should be taken after at least 3 air changes from the start of the test.

11.2.2 If there are enough data points and data are sufficiently smooth, the emission rate can be calculated by Eq 7. The calculation method gives emission rate values at n-1 time points if concentration values are given at n+1 time points.

NOTE 7—Eq 17 involves the subtraction of two large numbers, $C(t_i)$ and $C(t_{i-1})$ or $C(t_{i+1})$, to get a small number, $\Delta C(t_i)$. Numerically, this process has high potential to introduce propagated error into the results. The uncertainty (error) in the measurement of VOC concentrations may result in relatively scattered data of concentration over time, and may result in a negative emission rate when Eq 20 is used. In this case, the concentration data may be smoothed using a moving average technique before they are used for calculating the emission rate. However, such an analysis should be used only to identify the trend of emission rates. For a more quantitative analysis, the procedure described in section 11.3.2.2 is preferred.

11.3 *Calculations of Emission Rate Using Appropriate Source Models:*

11.3.1 *Selection of Source Models*—A mathematical model can be used to describe the emission factor as a function of time. Choosing a proper model is as important as collecting quality data during the chamber testing. For example, a commonly used simple empirical model is the first-order decay source model:

$$R(t) = R_0 e^{-kt} \quad (20)$$

where:

R_0 = initial emission rate, mg/h, and

k = first-order decay constant, 1/h.

NOTE 8—Models based on fundamental mass transfer principles are also available [for example, Little et al. 1994 (10), Guo et al. 1998 (31), Awad 1999 (7), and Yang 1999 (8)]. These models are more advanced because they can predict emission rates over a longer period of time than the empirical models. However, more complicated data analysis procedures are needed to estimate the coefficients for these models. Readers interested in the more advanced models are encouraged to review the references listed at the end of this practice.

11.3.2 *Determination of Model Coefficients*—The following two approaches can be used to determine the coefficients for a selected model:

11.3.2.1 Fit the model to the emission factor obtained from the direct calculation methods in section 11.2.1 by using non-linear regression techniques. Many commercial software packages can be used for such analysis. For example, if the first-order decay model is chosen, Eq 20 should be fitted to the emission rate data to determine R_0 and k . As noted before, this method is useful for identifying the trend of emission rate. Once the trend is identified (that is, a specific model is found

to better fit the data than others), it is recommended that the following method be used for a more accurate estimation of the model coefficients.

11.3.2.2 Fit the model directly to the measured concentration versus time data:

For example, if the first-order decay model is chosen and the chamber sink effect is negligible, the concentration at the chamber return or exhaust duct can be described by solving Eq 1 (assuming $C=0$ at $t=0$, see Guide D 5116):

$$C(t) = \frac{R_0(e^{-kt} - e^{-Nt})}{V(N-k)} \quad (21)$$

Eq 23 can be directly fitted to the measured concentration versus time data using non-linear regression techniques to determine coefficients R_0 and k .

For models for which an explicit mathematical expression for the concentration versus time data is not available, or the solution is too complicated to handle (for example, when the chamber sink effect is not negligible; see section 11.4), the differential equation (Eq 1) needs to be solved numerically to determine the model coefficients. Commercial software packages are readily available for such analysis.

11.4 *Consideration of the Sink Effect*—If the chamber sink effect for the VOCs measured is significant, the adsorption and desorption coefficients determined in section 8.6.3 should be used in solving the following set of equations for the emission rate, $R(t)$:

$$V \frac{dC(t)}{dt} = R(t) + A_s k_d m(t) - A_s k_a C(t) - QC(t) \quad (22)$$

$$\frac{dm(t)}{dt} = k_a C(t) - k_d m(t) \quad (23)$$

at $t = 0$; $C(t) = 0$; $m(t) = 0$

where:

V = air volume of the chamber system (chamber plus the recirculation loop), m^3 ,

$C(t)$ = concentration, mg/m^3 ,

t = time, h,

A_s = sink surface area of the chamber system, m^2 ,

k_d = desorption rate constant of the chamber system, $1/h$,

m = mass adsorbed by the chamber system, mg/m^2 ,

k_a = adsorption rate constant of the chamber system, m/h , and

Q = clean air flow rate (which can be measured at clean air supply duct or determined by a tracer gas test), m^3/h .

Note that both k_a and k_d are determined by the method described in section 8.6.3. Also note that the non-reversible sink effect is not accounted for by the above procedure.

11.5 *Calculation of the Emission Factor*—The emission factor is calculated by:

$$EF(t) = \frac{R(t)}{A_m} \quad (24)$$

where:

$EF(t)$ = emission factor at time t , mg/h , $mg/m/h$, $mg/m^2/h$, $mg/m^3/h$, and $mg/kg/m^3/h$ for unit, line, area, volume and mass sources, respectively; and

A_m = amount of materials/products tested in the chamber, unit, m, m^2 , m^3 , and kg for unit, line, area, volume, or mass emission sources, respectively.

11.6 *Use of Emission Models for Interpolation and Extrapolation*—A model with its coefficients determined from the measured concentration data can be used for interpolation if it fits the measured data satisfactorily (for example, Coefficient of Determination > 0.9). However, its validity for extrapolating the test results to a time beyond the test period depends on how well the emission process is physically described by the model. In a product-specific test protocol, the emission characteristics of the specific product type should be used to specify the time period within which the model is valid.

12. Report of the Test Results

12.1 The report should generally include the following information:

12.1.1 *Testing Objectives*—The purpose of the testing project and intended use of the results.

12.1.2 *Testing Laboratory Identification*—The name, address, phone/fax numbers, and contact person.

12.1.3 *Product Identification*—The name, specific identifiers from the manufacturer, and a brief description of the product, its application, and history.

12.1.4 The procedure of collecting, packaging, handling, shipping, and storage of material samples.

12.1.5 *Facility and Equipment Identification*—A general description of the facilities and equipment, including chemical sampling and analysis.

12.1.6 *Test Conditions*—Including temperature, humidity, air change rate, and dimensions of the test specimen.

12.1.7 *Results*—(1) names of VOCs identified in the pre-screening analysis; (2) basis of selecting the individual VOCs for environmental chamber testing; (3) concentration versus time data; and (4) emission factors calculated and/or the selected model and its coefficients for TVOCs and selected individual VOCs. The report should clearly state all of the sampling, recovery, and analytical conditions relating to the determination of all analytes, as well as the method of calculating TVOC values.

NOTE 9—The TVOC value is a method-dependent measurement. When reporting TVOC values, the user of this practice should indicate the measurement method used, including a detailed description of the adsorbents employed, the sampling volume, instruments, and analytical conditions. It is recommended that the VOC range, expressed as vapor pressure (v.p.) at 25 °C, of a given method be reported in parentheses with TVOC results; for example, TVOC-by-GC/MS (v.p. 150 to 0.3 kPa) = 10 mg/m^3 .

NOTE 10—The European Union and WHO define VOCs by different criteria. The WHO definition is based upon boiling point; whereas, the EU definition contains a specific list of 64 compounds. The definition in Terminology D 1356 may exclude some of the VOCs listed by the European Union (for example, 4-phenylcyclohexene, 2-butoxyethoxyethanol, and some of the higher boiling n-alkanes).

12.1.8 *Reference*—Refer to this practice and others as appropriate.

12.2 Report all values in SI units unless specified otherwise.

13. Quality Control and Quality Assurance

13.1 *Quality Assurance/Control (QA/QC) Plan*—A QA/QC plan should be designed and implemented to ensure the

integrity of the measured and reported data obtained during product evaluation studies. This plan should encompass all facets of the measurement program from sample receipt to final review and issuance of reports.

13.2 Data Quality Objectives/Acceptance Criteria—The QA/QC plan should be based on established data quality objectives and acceptance criteria that will depend on the purpose of the testing and the capability of the laboratory (equipment and personnel) to conduct the test procedures. Data quality objectives should be established for the following parameters prior to initiating the testing program:

13.2.1 Test Material/Product Transfer Time and Environmental Conditions—Tolerance limits should be established for the elapsed time from production to testing under an acceptable range of specified environmental conditions.

13.2.2 Test Chamber Conditions and Test Results—Precision and accuracy limits should be established for each parameter in Table 2.

Accuracy certifications are supplied by the manufacturers of the sensors who calibrate them against National Institute of Standards and Technology (NIST)-traceable primary sources.

Accuracy checks are performed with independent sensors calibrated against NIST-traceable primary standards. Precision measurements are obtained in the laboratory by continuous recording of the parameters. Non-compliance requires immediate correction and/or replacement of sensors. Calibrated replacements should be retained in the laboratory. Experience shows that routine calibration and tracking of precision can prevent non-compliance.

TABLE 2 Recommended Accuracy and Precision Limits Parameters

Parameter	Accuracy (as bias)	Precision
Temperature, °C	±0.5	±0.5
Relative humidity, %	±5.0	±5.0
Air flow rate, %	±5.0	±5.0
Area of the testing surface of the specimen, %	±1.0	±1.0
Time, %	±1.0	±1.0
Organic concentration, %RSD ^A	...	±15.0
Emission factor, % RSD ^A	...	±20.0

^A RSD= Relative standard deviation = $(s/m) \times 100$ %, where, s = estimate of the standard deviation; and m = mean. For the concentration, RSD is calculated from replicate air samples taken at the median of the chamber concentration observed during the test period. For the emission factor, the RSD is calculated from replicate standard source tests described in section 8.6.3 using the constant source procedure.

13.2.3 Record Keeping and Logs—Various documentation requirements shall be implemented for all test parameters including environmental chamber and analytical performance. Many of these are identified in Guide D 5116. Additionally, the identity of persons conducting each procedure shall be recorded. All devices used, date and time of tests, and the test data should be part of QA/QC recording process. Completeness of records demonstrates the care and attention given to the QC process.

13.3 Calibration—Calibration must be frequent enough to ensure performance of the system within specified parameters. Frequency of calibration should be determined prior to the test, and periodic equipment checks should verify the acceptable performance. All calibration and verification measurements should be recorded including the time, equipment description, and measurement data.

13.4 Accuracy Determinations—Accuracy determinations require measurements of a known emission source (for example, permeation tubes, spiked samples) or test gas. These measurements should be made prior to establishing the project data quality objectives, and shall be consistent with the overall testing objectives. The procedures and materials used for establishing the accuracy of the measurement system should be recorded.

13.5 Precision—Precision determinations require replications sufficient to establish the systematic variation associated with all measurements. When multiple chambers are used as part of an experiment, duplicate samples shall be used. Variation in test data from a single chamber and among chambers can be established by use of standardized sources such as permeation tubes for determining organic concentrations and calculated emission rates.

13.6 Duplicate Analysis—No fewer than 15 % of the air samples collected should be subject to duplicate analysis. The results of such analyses shall be recorded and assessed to determine the adequacy of the total system performance relative to the testing objectives.

13.7 Charting—Charting QC data will allow analysis of system performance and observation of anomalous or unacceptable deviations.

14. Keywords

14.1 building materials; environmental test chambers; full-scale chamber testing; indoor air quality; indoor materials; indoor products; material emissions; organic emissions

REFERENCES

- (1) ASHRAE 1997c. Space air diffusion. ASHRAE Handbook: Fundamentals. Chapter 31. ASHRAE, 1791 Tullie Circle, N.E., Atlanta, GA 30329.
- (2) Wolkoff, P. 1998. "Impact of air velocity, temperature, and humidity on long-term VOC emissions from building products," *Atmospheric Environment*. Vol. 32, No. 14/15, pp. 2659-2668.
- (3) Van der Wal, Jan F., Ank W. Hoogeveen and Paul Wouda. 1997. "The influence of temperature on the emission of volatile organic compounds from PVC flooring, carpet, and paint.," *Indoor Air*. 7: 215-221.
- (4) Brown, S.K. 1999. *Indoor Air* 9: 259-267.
- (5) Roache N., E. Howard, Z. Guo, and R. Fortmann. 1996. "Observations on application of the field and laboratory emission cell (FLEC) for latex paint emissions—effect of relative humidity," *Indoor Air '96*. Vol. 2. pp. 657-662. The 7th International Conference on Indoor Air Quality and Climate, July 21-26, 1996. Nagoya, Japan.
- (6) Zhang, J.S., J.M. Kanabus-Kaminska, and C.Y. Shaw. 1996a. "A full-scale test chamber for material emission studies and indoor air quality modelling," In *Characterizing Sources of Indoor Air Pollution and Related Sink Effects*, ASTM STP 1287, Bruce A. Tichenor, Ed., American Society for Testing and Materials, Philadelphia, PA 19019 pp. 58-66.
- (7) Awad, S. B. 1999. *Fundamental Mass Transfer Modeling of Emissions of Volatile Organic Compounds from Building Materials*. Ph. D. Thesis. Department of Mechanical and Aerospace Engineering, Carleton University, Ottawa, Canada.
- (8) Yang, X. 1999. *Study of Building Material Emissions and Indoor Air Quality*. Ph.D. Thesis. Department of Architecture, MIT, Cambridge, MA 02139-4307.
- (9) Wolkoff P., U.D. Kjar, H.N. Knudsen, and P.A. Nielsen. 1996. "Characterization of emissions from building products: long-term chemical evaluation, impact of air velocity and concentration," *Indoor Air '96*, 4:337. The 7th International Conference on Indoor Air Quality and Climate, July 21-26, 1996. Nagoya, Japan.
- (10) Little, J.C., A.T. Hodgson, and A.J. Gadgil. 1994. "Modeling emissions of volatile organic compounds from new carpets," *Atmospheric Environment*, Vol. 28, pp. 227-234.
- (11) Mathews, T.J., C.V. Thompson, D.L. Wilson, A.R. Hawthorne, and D.T. Mage. 1987. "Air velocities inside domestic environments: an important parameter for passive monitoring," *Indoor Air '87*, Proceedings of the 4th International Conference on Indoor Air Quality and Climate, Institute for Water, Soil and Air Hygiene, West Berlin, Germany. Vol. 1, August 1987. pp. 154-158.
- (12) Zhang, J.S., C.Y. Shaw, L.C. Nguyen-Thi, R.A. MacDonald, and G. Kerr. 1995. "Field measurements of boundary layer flows in ventilated rooms," *Transactions of ASHRAE*. 101(2):1-9.
- (13) ASHRAE 1997a. Residential cooling and heating load calculations. ASHRAE Handbook: Fundamentals. Chapter 27. ASHRAE, 1791 Tullie Circle, N.E., Atlanta, GA 30329.
- (14) ASHRAE 1997b. Ventilation and infiltration. ASHRAE Handbook: Fundamentals. Chapter 25. ASHRAE, 1791 Tullie Circle, N.E., Atlanta, GA 30329.
- (15) Reardon, J.T., and J.S. Zhang. 1995. "A comparison of three models of air infiltration in houses against field measurement," *Second International Conference on Indoor Air Quality, Ventilation and Energy Conservation in Buildings* (Montréal, Québec, Canada, 1995) pp. 377-384, vol. 1.
- (16) ASHRAE 1995. Clean spaces. ASHRAE Handbook: HVAC Applications. Chapter 15. ASHRAE, 1791 Tullie Circle, N.E., Atlanta, GA 30329.
- (17) Guo, Z. 1996. *Z-30 Indoor Air Quality Simulator: User's Guide*. Acurex Environmental Corporation, P.O. Box 13109, Research Triangle Park, NC 27709.
- (18) Zhang, J.S. and C.Y. Shaw. 1997. Modeling of Volatile Organic Compound (VOC) Emissions from Building Materials/Furnishings—A Literature Review, IRC/NRC Internal Report No. IRC-IR-755. pp. 1-24.
- (19) Kirkpatrick, A. T. and J.S. Elleson. 1996. *Cold Air Distribution System Design Guide*. ASHRAE, 1791 Tullie Circle, N.E., Atlanta, GA 30329.
- (20) Fortmann, R., K. Krebs, S. Marfiak, and M. Mason, 1995. "Sampling and Analysis of VOCs for Indoor Air Source Characterization," in *Proceedings of Engineering Solutions to Indoor Air Quality Problems*, VIP-51: Air & Waste Management Association: Pittsburgh, PA 15122, 1995.
- (21) Keith, L.H., W. Crummett, J. Deegan, R.A. Libby, J.K. Taylor, and G. Wentler, *Principles of Environmental Analysis*. *Anal.Chem.* 55:2210 (1983).
- (22) Taylor, J.K. *Quality Assurance of Chemical Measurements*; Lewis: Chelsea, MI 48118, 1987; pp 79-82.
- (23) EPA QA/R-5: (November 1999, Iterim Final), EPA Requirements for Quality Assurance Project Plans for Environmental Data Operations. U. S. Environmental Protection Agency, Quality Assurance Division, Washington, DC 20460.
- (24) Zhang, J.S., J.M. Kanabus-Kaminska, C.Y. Shaw, J.H. Weichert, E. Luszytk, R.J.Magee, and M.A. Brouzes, 1996b. Performance evaluation of a full-scale chamber for material emission tests and studies. *Indoor Air '96*, The 7th International Conference on Indoor Air Quality and Climate (Nagoya, Japan, 1996) pp. 373-378, vol. 3 (NRCC-38437).
- (25) Mason, M. A., E. M. Howard, Z. Guo, and M. Bero. 1997. *Characterizing Sink Effects in Large Environmental Chambers*. In *Engineering Solutions to Indoor Air Quality Problems*, VIP-75, Air & Waste Management Association, P.O. Box 1020, Sewickley, PA 15143-1020.
- (26) Mason, M.A., Z. Guo, E. Howard, J.S. Zhang, G. Nong, and S. Brown, 1999. "Comparison of the sink characteristics of three full-scale environmental chambers," *Indoor Air 99*, 8th International Conference on Indoor Air Quality and Climate (Edinburgh, Scotland, 1999) Vol. 5, pp. 149-154.
- (27) Tichenor, B. A., Z. Guo, L. E. Sparks, and M. A. Mason. 1991. The interaction of vapour phase organic compounds with indoor sinks. *Indoor Air*, 1:23.
- (28) Zhang, J.S. G. Nong, C.Y. Shaw, 1999a. "Sink characteristics of a full-scale environmental chamber and their impact on material emission testing," Accepted for publication by ASHRAE Transactions, pp. 1-32 (NRCC-42799).
- (29) Jayjock, M.A., R. Deepak, E.H. Nungesser, and W.D. Shade. 1995. Development and evaluation of a source/sink model of indoor air concentrations from isothiazolone treated wood used indoors. *Am. Ind. Hyg. Assoc. J.* 56(6): 546-557.
- (30) Zhang, J.S., G. Nong, M. Mason, E. Howard, and S.K. Brown, 1999b. "Assessing the performance of full-scale environmental chambers using an independently measured emission source," *Indoor Air 99*, 8th International Conference on Indoor Air Quality and Climate (Edinburgh, Scotland, 1999) Vol. 5, pp 81-86.
- (31) Guo, Z., L.E. Sparks, B.A. Tichenor, and J.C.S. Chang. 1998. Predicting the emissions of individual VOCs from petroleum-based indoor coatings. *Atmospheric Environment*, Vol. 32, No. 2, pp. 231-237.

ASTM International takes no position respecting the validity of any patent rights asserted in connection with any item mentioned in this standard. Users of this standard are expressly advised that determination of the validity of any such patent rights, and the risk of infringement of such rights, are entirely their own responsibility.

This standard is subject to revision at any time by the responsible technical committee and must be reviewed every five years and if not revised, either reapproved or withdrawn. Your comments are invited either for revision of this standard or for additional standards and should be addressed to ASTM International Headquarters. Your comments will receive careful consideration at a meeting of the responsible technical committee, which you may attend. If you feel that your comments have not received a fair hearing you should make your views known to the ASTM Committee on Standards, at the address shown below.

This standard is copyrighted by ASTM International, 100 Barr Harbor Drive, PO Box C700, West Conshohocken, PA 19428-2959, United States. Individual reprints (single or multiple copies) of this standard may be obtained by contacting ASTM at the above address or at 610-832-9585 (phone), 610-832-9555 (fax), or service@astm.org (e-mail); or through the ASTM website (www.astm.org).