



Standard Test Method for Thermal Protective Performance of Materials for Protective Clothing for Hot Surface Contact¹

This standard is issued under the fixed designation F 1060; the number immediately following the designation indicates the year of original adoption or, in the case of revision, the year of last revision. A number in parentheses indicates the year of last reapproval. A superscript epsilon (ϵ) indicates an editorial change since the last revision or reapproval.

1. Scope

1.1 This test method is used to rate textile materials for thermal resistance and insulation when exposed for a short period of time to a hot surface with a temperature up to 600°F (316°C). This test method is applicable to woven fabrics, knit fabrics, battings, and sheet structures intended for use as clothing for protection against short exposure to hot surfaces. It is not intended for use in evaluating materials exposed to any other thermal exposure such as radiant energy or open flames. This test method is currently useful as a research and development tool.

1.2 This test method should be used to measure and describe the properties of materials, products, or assemblies in response to heat under controlled laboratory conditions and should not be used to describe or appraise the thermal hazard or fire risk of materials, products, or assemblies under actual exposure conditions.

1.3 The values as stated in SI units are to be regarded as the standard. The values in parentheses are given for information only.

1.4 *This standard does not purport to address all of the safety concerns, if any, associated with its use. It is the responsibility of the user of this standard to establish appropriate safety and health practices and determine the applicability of regulatory limitations prior to use.*

2. Referenced Documents

2.1 ASTM Standards:

D 123 Terminology Relating to Textiles²

D 1776 Practice for Conditioning Textiles for Testing²

D 4391 Terminology Relating to The Burning Behavior Of Textiles³

F 1494 Terminology Relating to Protective Clothing⁴

¹ This test method is under the jurisdiction of ASTM Committee F23 on Protective Clothing and is the direct responsibility of Subcommittee F23.80 on Flame and Thermal.

Current edition approved April 10, 2001. Published June 2001. Originally published as F 1060 - 87. Last previous edition F 1060 - 87(1993) ^{ϵ 1}.

² *Annual Book of ASTM Standards*, Vol 07.01.

³ *Annual Book of ASTM Standards*, Vol 07.02.

⁴ *Annual Book of ASTM Standards*, Vol 11.03.

3. Terminology

3.1 *Definitions*—In testing thermal protection clothing material, the response to hot surface contact is indicated by the following descriptive terms:

3.1.1 *charring*—the formation of a carbonaceous residue as the result of pyrolysis or incomplete combustion.

3.1.2 *embrittlement*—the formation of a brittle residue as a result of pyrolysis or incomplete combustion.

3.1.3 *heat flux*—the thermal intensity indicated by the amount of energy transmitted per unit area and per unit time ($\text{cal/cm}^2\cdot\text{s}$) (watts/cm^2).

3.1.4 *human tissue heat tolerance*—in the testing of thermal protective materials, the amount of thermal energy predicted to cause a pain sensation or a second degree burn in human tissue.

3.1.5 *ignition*—the initiation and continuation of combustion.

3.1.6 *melting*—a response evidenced by softening of the material, resulting in a nonreversible change.

3.1.7 *shrinkage*—a response evidenced by reduction in specimen size.

3.1.8 *sticking*—a response evidenced by softening and adherence of the material to the hot surface or other material.

3.1.9 *thermal end point*—in the testing of thermal protective materials, the point at which the sensor response on the recorder chart intersects the human tissue burn tolerance criteria overlay.

3.2 For all terminology related to protective clothing, see Terminology F 1494.

3.3 For definitions of other textile terms used in this test method, refer to Terminology D 123.

4. Summary of Test Method

4.1 This test method measures the performance of insulative materials. A material is placed in contact with a standard hot surface. The amount of heat transmitted by the material is compared with the human tissue tolerance and the obvious effects of the heat on the material are noted.

4.2 The temperature of the hot surface is measured/controlled with a thermocouple and the heat transmitted by the test specimen is measured with a copper calorimeter. The calorimeter temperature increase is a direct measure of the heat energy received.

4.3 A contact pressure of 3kPa (0.5 psi) is used to compare material performance under controlled conditions. If a different pressure is chosen to represent a specific use condition, where it is used should be noted under test conditions (13.1.2.3).

4.4 The material performance is determined from the amount of heat transferred by the specimen and the observed effect of the heat exposure on the specimen. The thermal protection is the exposure time required to cause the accumulated heat received by the sensor to equal the heat that will result in a pain sensation (see Table 1) or cause a second degree burn in human tissue (see Table 2), as predicted from comparison of heat transfer data with human tissue heat tolerance curves (see Table 1 and Table 2).

5. Significance and Use

5.1 This test method rates textile materials intended for use as protective clothing against exposure to hot surfaces, for their thermal insulating properties and their reaction to the test conditions.

5.2 The thermal protection time as determined by this test method will relate to the actual end-use performance only to the degree that the end-use exposure is identical to the exposure used in this test method, that is, conductive energy from hot surfaces up to 600°F (300°C) and under a pressure of 3kPa (0.5 psi).

5.3 The procedure maintains the specimen in a static, horizontal position under a standard pressure and does not involve movement.

5.4 This test method for materials for thermal protective performance is intended for use in comparing the relative performance of various materials.

6. Apparatus

6.1 *General Arrangement*—The arrangement of the individual components of the test apparatus is shown in Fig. 1.

6.1.1 Alternatively, transmit temperature output readings to a data acquisition unit, then computer process to obtain the test result.

6.2 *Hot Plate*—Shall have a flat heated surface with the smallest dimension, a minimum of at least 200 mm (8 in.) and

have the ability to achieve a temperature of at least 371°C (700°F) and to permit temperature control within 2.8°C (± 5°F).

6.3 *Surface plate*—The flat plate shall be 6.4 mm (¼ in.) thick, 140 by 140 mm (5.5 by 5.5 in.) wide, with a 2.4 mm (3/32 in.) hole drilled from the edge to the center of the plate (Fig. 2). Use either electrolytic copper or T-1100 aluminum surface plates. The surface plate must be flat, smooth, and free from pits and cavities. (Flatness is indicated by negligible light passing between a straight edge and the plate surface.) Loss of the original mill finish (as judged with the naked eye) or warping, or both, may result in failure to achieve calibration with the reference standard.

6.4 *Sensor*—A copper calorimeter mounted in an insulating block with added weight and constructed as shown in Figs. 3 and 4 with the standard characteristics listed below. The following equations permit the determination of the total incident heat energy from the copper calorimeter:

$$q = \frac{mass \times C_p \times (Temp_{final} - Temp_{initial})}{area \times (time_{final} - time_{initial})} \tag{1}$$

where:

- q = heat flux (cal/cm²s),
- $mass$ = mass of the copper disk/slug (g),
- C_p = heat capacity of copper (0.09426 cal/g°C at 100°C),
- $temp_{final}$ = final temperature of copper disk/slug at time_{final} (°C),
- $temp_{initial}$ = initial temperature of copper disk/slug at time_{initial} (°C),
- $area$ = area of the exposed copper disk/slug (cm²),
- $time_{final}$ = ending time (s), and
- $time_{initial}$ = starting time (s).

For a copper disk/slug that has a mass of 18.0 g and exposed area of 12.57 cm², the determination of heat flux reduces to:

$$q = \frac{0.135 \times (Temp_{final} - Temp_{initial})}{(time_{final} - time_{initial})} \tag{2}$$

If you use a copper disk/slug with a different mass and/or exposed area, the constant factor should be adjusted correspondingly. Also note that a different mass/surface area sensor will give different rates of temperature change to incident heat energy so the calculations made later will need to note this and make appropriate changes to correct (for example, see 10.3, 12.1.2, 13.1.3.1). The calorimeter must fit securely in the insulating block and its surface must be flush with the face of

TABLE 1 Human Tissue Tolerance to Pain Sensation

| Exposure Time | Heat Flux | | Total Heat | | Calorimeter Equivalent | | |
|---------------|--------------------------|-------------------|------------------------|-----------------------|------------------------|--------|-------|
| | cal/cm ² -sec | W/cm ² | cal/cm ² -s | W sec/cm ² | ΔT°, F | ΔT°, C | ΔmV |
| 1.0 | 0.640 | 2.70 | 0.640 | 2.70 | 8.53 | 4.74 | 0.250 |
| 1.5 | 0.475 | 2.00 | 0.713 | 3.00 | 9.51 | 5.28 | 0.275 |
| 2.0 | 0.385 | 1.61 | 0.770 | 3.22 | 10.27 | 5.71 | 0.293 |
| 3.0 | 0.280 | 1.17 | 0.840 | 3.51 | 11.20 | 6.22 | 0.322 |
| 5.0 | 0.195 | 0.82 | 0.975 | 4.08 | 13.00 | 7.22 | 0.375 |
| 7.0 | 0.155 | 0.65 | 1.085 | 4.54 | 14.47 | 8.04 | 0.420 |
| 10.0 | 0.118 | 0.49 | 1.180 | 4.94 | 15.73 | 8.74 | 0.458 |
| 20.0 | 0.076 | 0.32 | 1.520 | 6.36 | 20.27 | 11.26 | 0.582 |
| 30.0 | 0.060 | 0.25 | 1.800 | 7.53 | 24.00 | 13.33 | 0.690 |
| 50.0 | 0.060 | 0.25 | 3.000 | 12.55 | 40.00 | 22.22 | 1.150 |

TABLE 2 Human Tissue^A Tolerance to Second Degree Burn

| Exposure Time, s | Heat Flux | | Total Heat | | Calorimeter ^B | | Equivalent, ΔmV |
|------------------|------------------------|-------------------|------------------------|-------------------|--------------------------|--------|-----------------|
| | cal/cm ² ·s | W/cm ² | cal/cm ² ·s | W/cm ² | ΔT, °F | ΔT, °C | |
| (1) | (2) | (3) | (4) | (5) | (6) | (7) | (8) |
| 1 | 1.2 | 5.0 | 1.20 | 5.0 | 16.0 | 8.9 | 0.46 |
| 2 | 0.73 | 3.1 | 1.46 | 6.1 | 19.5 | 10.8 | 0.57 |
| 3 | 0.55 | 2.3 | 1.65 | 6.9 | 22.0 | 12.2 | 0.63 |
| 4 | 0.45 | 1.9 | 1.80 | 7.5 | 24.0 | 13.3 | 0.69 |
| 5 | 0.38 | 1.6 | 1.90 | 8.0 | 25.3 | 14.1 | 0.72 |
| 6 | 0.34 | 1.4 | 2.04 | 8.5 | 27.2 | 15.1 | 0.78 |
| 7 | 0.30 | 1.3 | 2.10 | 8.8 | 28.0 | 15.5 | 0.80 |
| 8 | 0.274 | 1.15 | 2.19 | 9.2 | 29.2 | 16.2 | 0.83 |
| 9 | 0.252 | 1.06 | 2.27 | 9.5 | 30.2 | 16.8 | 0.86 |
| 10 | 0.233 | 0.98 | 2.33 | 9.8 | 31.1 | 17.3 | 0.89 |
| 11 | 0.219 | 0.92 | 2.41 | 10.1 | 32.1 | 17.8 | 0.92 |
| 12 | 0.205 | 0.86 | 2.46 | 10.3 | 32.8 | 18.2 | 0.94 |
| 13 | 0.194 | 0.81 | 2.52 | 10.6 | 33.6 | 18.7 | 0.97 |
| 14 | 0.184 | 0.77 | 2.58 | 10.8 | 34.3 | 19.1 | 0.99 |
| 15 | 0.177 | 0.74 | 2.66 | 11.1 | 35.4 | 19.7 | 1.02 |
| 16 | 0.168 | 0.70 | 2.69 | 11.3 | 35.8 | 19.8 | 1.03 |
| 17 | 0.160 | 0.67 | 2.72 | 11.4 | 36.3 | 20.2 | 1.04 |
| 18 | 0.154 | 0.64 | 2.77 | 11.6 | 37.0 | 20.6 | 1.06 |
| 19 | 0.148 | 0.62 | 2.81 | 11.8 | 37.5 | 20.8 | 1.08 |
| 20 | 0.143 | 0.60 | 2.86 | 12.0 | 38.1 | 21.1 | 1.10 |
| 25 | 0.122 | 0.51 | 3.05 | 12.8 | 40.7 | 22.6 | 1.17 |
| 30 | 0.107 | 0.45 | 3.21 | 13.4 | 42.8 | 23.8 | 1.23 |

^A Stoll, A. M. and Chianta, M. A., "Method and Rating System for Evaluations of Thermal Protection," *Aerospace Medicine*, Vol 40, 1969, pp. 1232-1238 and Stoll, A. M. and Chianta, M. A., Heat Transfer through Fabrics as Related to Thermal Injury, "Transaction-New York Academy of Sciences," Vol 33 (7), Nov. 1971, pp 649-670.

^B A calorimeter with an iron/constantan thermocouple.

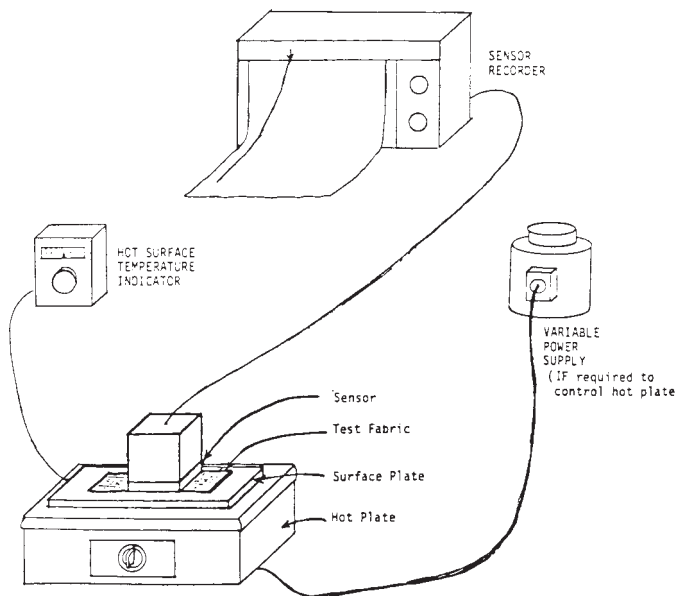
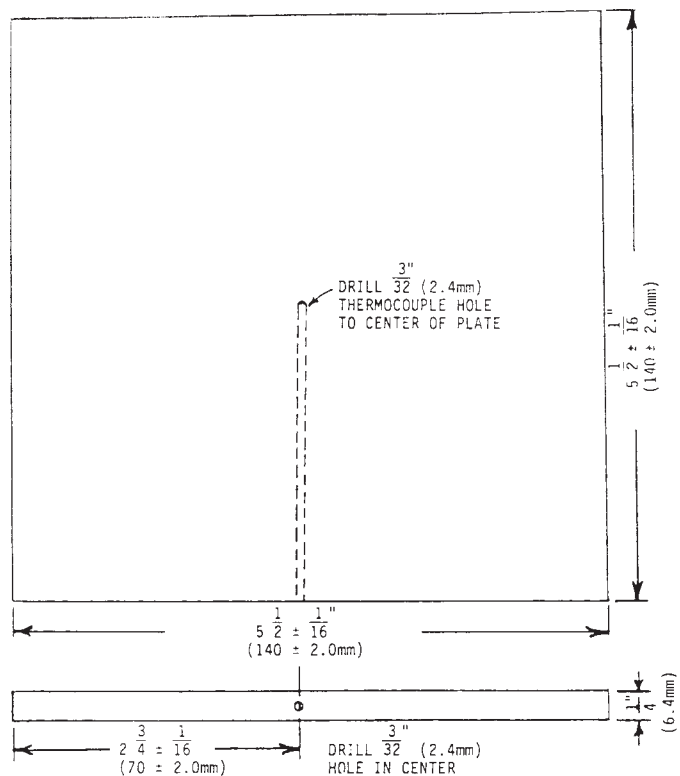

FIG. 1 Thermal Protective Performance Apparatus, Hot Surface Contact



Material: Electrolytic Copper or T-1100 aluminum
FIG. 2 Surface Plate

the insulating block. (**Warning**—Surface variations may result in failure to achieve calibration with the reference standard.)

6.5 *Calibration Specimen*—Six new, not previously tested sheets of ordinary newspaper with total thickness of 0.53 ± 0.05 mm (0.021 ± 0.002 in.).

6.6 *Recorder*—Any strip chart recorder with full-scale deflection of at least 150°C (300°F) or 10 mV and sufficient sensitivity and scale divisions to read sensor response to 1°C (±2°F) or ±0.05 mV. A chart speed to read exposure time to ±0.1 s is required, 13 mm/s (0.5 in./s) is satisfactory.

7. Hazards

7.1 Perform the test in a hood or a ventilated area to carry away degradation products, smoke, and fumes. Exercise care to prevent contact with hot surfaces. Use protective gloves when handling hot objects. Have an appropriate portable fire extinguisher nearby.

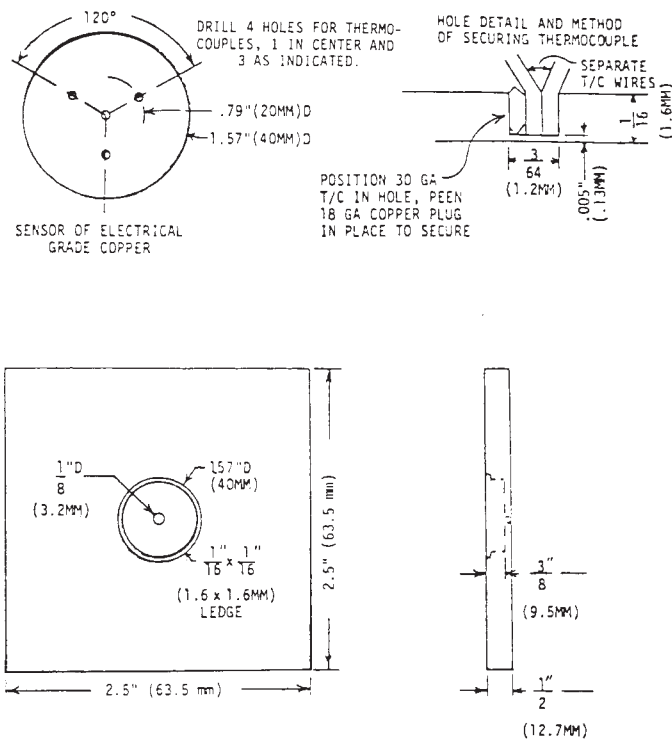

SENSOR SUPPORT OF SOFT INSULATION BOARD
 CONNECT 4 T/C IN PARALLEL, SILVER SOLDER CONNECTIONS.
 BRING COMMON LEAD OUT OF CENTER HOLE OF SUPPORT.
 SENSOR TO BE SNUG FIT AND FLUSH TO SURFACE IN INSULATION BOARD. SPRAY PAINT SENSOR FLAT BLACK.

FIG. 3 Details of Calorimeter Construction

8. Sampling

8.1 *Lot Size*—For acceptance sampling purposes, a lot is defined as a single shipment of a single style of fabric. A lot constitutes all or part of a single customer order.

8.2 *Lot Sample*—As a lot sample for acceptance testing, take at random the number of rolls of fabric directed in an applicable material specification or other agreement between the purchaser and the supplier.

8.3 *Laboratory Sample*—As a laboratory sample, take from the outside of each roll in the lot sample a full width swatch of fabric 1 m (1 yd) long after discarding a full width length of at least 1 m (1 yd) from the very outside of each roll.

9. Specimen Preparation

9.1 Cut and identify five test specimens from each swatch in the laboratory sample. Make each test specimen 100 by 150 ± 2 mm (4 by 6 ± 1/16 in.) with two of the sides of the specimen parallel with the warp yarns in woven fabric samples, with the wales in knit fabric samples, or with the length of the fabric in batts or sheet structure. Do not cut samples closer than 2 % of the fabric width from the selvage. Cut specimens from a diagonal zone across the sample swatch so as to get as representative a sample of all yarns present as practical.

9.2 Alternatively cut test specimens from a finished garment. Cut specimens using the orientation indicated in 9.1. Test specimen shall not include any seam.

9.3 Bring the specimens to a controlled moisture content by preconditioning in a 48.9°C (120°F) oven for 4 h and then

exposing to a standard atmosphere for testing textiles, that is, in air maintained at a relative humidity of 65 ± 2 % and at a temperature of 21 ± 1°C (70 ± 2°F) for at least 4 h. See the portion of the Definitions Section of Practice D 1776 containing the definitions for “standard atmosphere for preconditioning textiles” and for “standard atmosphere for testing textiles.”

10. Calibration and Standardization

10.1 *Apparatus*—Center the surface plate on the hot plate and place a thermocouple in the thermocouple (T/C) well of the surface plate to measure exposure temperature.

10.2 *Test Exposure*—Adjust control to the hot plate to obtain desired temperature. Allow temperature to stabilize to within 2.8°C (±5°F) of the desired test temperature as indicated by three successive readings taken at least 5 min apart.

10.3 *Reference Standard*—Six new sheets of ordinary newspaper⁵ conditioned as specified in 9.3 are the calibration specimen used as a reference standard. When the reference standard is used with a plate temperature of 200 ± 3°C (392 ± 5°F), correct operation of the apparatus and data analysis are indicated with the results of Time to Pain = 1.0 ± 0.2 s and Time to Burn = 3.0 ± 0.3 s.

10.4 Sensor Care:

10.4.1 *Initial Temperature*—Cool the sensor after exposure with a jet of air or by contact with a cold surface. Reheat the sensor to approximate body temperature by contact with the palm of hand just prior to positioning over the test specimens. Do not adjust the zero setting of the recorder.

10.4.2 *Surface Reconditioning*—Inspect the sensor face immediately after each run. If it has collected any degradation products, or polymer has stuck to it, the surface requires reconditioning. Carefully clean the cooled sensor with acetone or petroleum solvent, making certain there is no ignition source nearby. If bare copper is showing, repaint the surface with a thin layer of flat black spray paint (emissivity > 0.95). After repainted surface has air dried, heat sensor on hot surface plate to at least 65°C (150°F) to “cure” paint prior to using the reconditioned sensor in a test run.

10.5 *Preparation of Human Tissue Heat Tolerance Overlays*—The thermal end point is determined with a plot of energy versus time to cause a pain sensation or second degree burn in human tissue. Plot, on the recorder chart paper, the calorimeter equivalent for second degree burn from Table 2, which corresponds to the recorder scale ΔT°F, ΔT°C, or ΔmV (column 6, 7, or 8) on the vertical axis and the corresponding time (column 1) on the horizontal axis. Use chart units based on the recorder full scale deflection and the chart speed to give a graph which compares directly with the recorder sensor trace. If pen deflection is from left to right, and paper movement down, plot from right to left—origin at lower right. If recorder trace differs, adjust the graph accordingly. Make an exact transparent duplicate for the overlay. Compare the overlay with the original to ensure that duplication did not change the overlay size. In like manner, plot the pain tolerance curve using data from Table 1.

⁵ The type of newsprint used by the *Wall Street Journal* has been found satisfactory for this purpose.

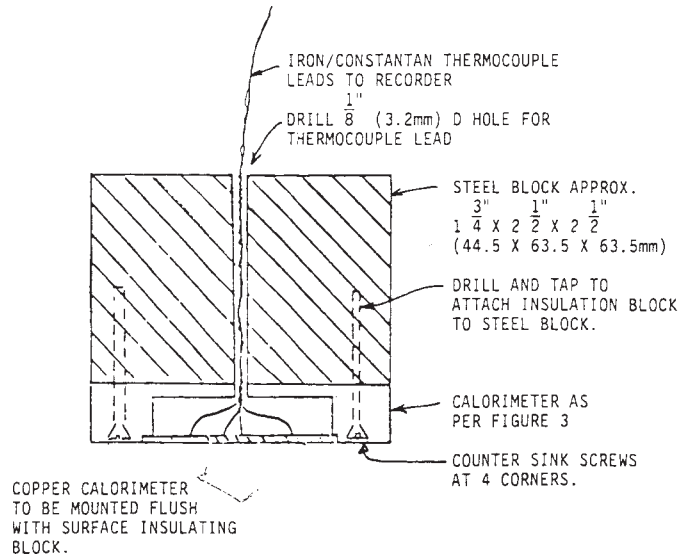

NOTE 1—Grind steel block to give total assembly weight of $3.125 \pm .025$ lb. (1417.5 ± 11 gr).

FIG. 4 Details of Calorimeter and Weight Assembly

11. Procedure

11.1 *Specimen Mounting*—Place the cut specimens on the table, and if multiple layers, in the order they are worn, with the surface worn next to the skin facing up. Center the sensor on the specimens and draw the long ends up either side of the sensor and hold in place by grasping the blocks weighting the sensor.

11.2 *Specimen Exposure*—Start the recorder chart movement and position the sensor on the hot surface plate. Continue the exposure until the sensor response exceeds the values of the calorimeter equivalent temperature rise for second degree burn (temperature rise of 35 to 40°F, 20 to 25°C, or 1.0 to 1.2 mV for long exposures). Assemblies that have superior insulation may not permit heat transfer that will exceed the heat criteria. In this case, stop the test after 1 min, or a period of time representing the desired use condition. Remove the sensor and specimen from the hot surface, separate specimen layers and start cooling the sensor. Expose three specimens or combinations of layers of materials.

12. Interpretation of Results

12.1 The information obtained from this test is an observation of the physical damage produced by the exposure, and the time predicted to cause a pain sensation or a second degree burn from the heat transferred through the test specimen. Refer to Terminology D 4391.

12.1.1 *Response to Hot Surface Contact*—After the exposed specimen has cooled, observe the effect of the exposure. The observed conditions may be described by one or more of the terms defined in Section 3.

12.1.2 *Exposure Time*—The time to the thermal end point is determined graphically from the recorder chart of the sensor response and the criterion overlay prepared in 10.5. Position the overlay on the recorder chart, matching the zero of the overlay with the point on the recorder chart corresponding to the time at which the sensor and the specimen were placed in

direct contact with the hot plate. Place the horizontal (time) axis in line with the initial trace of the pen. Keep the overlay square with the recorder chart. Exposure time is read to the nearest 0.1 s from the overlay chart at the point where the sensor response curve and the tissue tolerance curve cross. If the sensor response curve and the tissue tolerance curves do not cross, record “no pain” or “no burn” as the test result.

NOTE 1—The first indication of pen deviation may be determined as the intersection of the continuation of the time baseline of the tracer in the x direction, and the extension of the first straight line portion of the sensor response back toward the base line.

13. Report

13.1 State that the test has been performed in accordance with this ASTM designation F1060, and report the following information:

13.1.1 Material:

13.1.1.1 A detailed sample description including fabric weight and thickness, type treatments if any, source, and any other relevant information. Include data for all materials involved in this test;

13.1.1.2 Number of rolls in lot sample, and

13.1.1.3 Number of specimens tested.

13.1.2 *Conditions of Test if Other Than Standard*, such as:

13.1.2.1 Hot surface temperature;

13.1.2.2 Number of layers tested—single, multiple and order of layers, and

13.1.2.3 Contact pressure.

13.1.3 *Test Results*:

13.1.3.1 Human tissue criteria—pain, second degree burn, or both;

13.1.3.2 Exposure time for each specimen for each criterion used;

13.1.3.3 Average exposure time for all specimens tested for each criterion used, and

13.1.3.4 Description of the effect of the exposure energy as listed in 12.1.1.

14. Precision and Bias

14.1 *Precision*—A temporary precision statement is included, pending completion of an interlaboratory study that will allow stating both within-laboratory and between-laboratory precision.

14.1.1 *Single Laboratory Study*—Five multilayer material composites were tested in one laboratory, using one operator to measure time-to-pain and time-to-burn parameters, as required by the procedure. Five specimens were measured for each material. The data set was analyzed and precision reported for each material separately in the form of standard errors and critical differences.

14.1.2 *Within-Laboratory Precision*, based upon determination in one laboratory, is given in Table 3 for time-to-pain and time-to-burn (second degree), with each material shown separately.

14.1.3 Until the interlaboratory study is completed, users of the test method are advised to exercise conventional statistical caution in making any comparisons of test results.

14.2 *Bias*

14.2.1 The values of time-to-pain and time-to-burn can be defined only in terms of a test method.

14.2.2 This test method has no known bias.

14.2.3 There is no independent referee test method for determining whether or not this test method has any bias.

15. Keywords

15.1 hot surface contact; protective clothing; textiles; thermal; thermal resistance

TABLE 3 Within-Laboratory Precision Table – 95 % Probability Level Showing Values for Standard Error (SE) and Critical Difference (CD) (Single Laboratory/Single Operator Determination)

| Material | Time To Pain | | | Time to Burn | | |
|----------|--------------|-------|------|--------------|-------|------|
| | Sp in Av | SE | CD | Sp in Av | SE | CD |
| A | 1 | 1.071 | 3.00 | 1 | 1.307 | 3.66 |
| | 3 | 0.618 | 1.73 | 3 | 0.755 | 2.11 |
| test std | 5 | 0.479 | 1.34 | 5 | 0.584 | 1.64 |
| | 7 | 0.405 | 1.13 | 7 | 0.494 | 1.38 |
| B | 1 | 0.152 | 0.42 | 1 | 0.583 | 1.63 |
| | 3 | 0.088 | 0.25 | 3 | 0.337 | 0.94 |
| test std | 5 | 0.068 | 0.19 | 5 | 0.261 | 0.73 |
| | 7 | 0.057 | 0.16 | 7 | 0.220 | 0.62 |
| C | 1 | 0.415 | 1.16 | 1 | 0.428 | 1.20 |
| | 3 | 0.239 | 0.67 | 3 | 0.247 | 0.69 |
| test std | 5 | 0.185 | 0.52 | 5 | 0.191 | 0.54 |
| | 7 | 0.157 | 0.44 | 7 | 0.162 | 0.45 |
| D | 1 | 0.228 | 0.64 | 1 | 0.336 | 0.94 |
| | 3 | 0.132 | 0.37 | 3 | 0.194 | 0.54 |
| test std | 5 | 0.102 | 0.29 | 5 | 0.150 | 0.42 |
| | 7 | 0.086 | 0.24 | 7 | 0.127 | 0.36 |
| E | 1 | 0.705 | 1.97 | 1 | 1.377 | 3.85 |
| | 3 | 0.407 | 1.14 | 3 | 0.795 | 2.23 |
| test std | 5 | 0.315 | 0.88 | 5 | 0.616 | 1.72 |
| | 7 | 0.266 | 0.75 | 7 | 0.520 | 1.46 |

ASTM International takes no position respecting the validity of any patent rights asserted in connection with any item mentioned in this standard. Users of this standard are expressly advised that determination of the validity of any such patent rights, and the risk of infringement of such rights, are entirely their own responsibility.

This standard is subject to revision at any time by the responsible technical committee and must be reviewed every five years and if not revised, either reapproved or withdrawn. Your comments are invited either for revision of this standard or for additional standards and should be addressed to ASTM International Headquarters. Your comments will receive careful consideration at a meeting of the responsible technical committee, which you may attend. If you feel that your comments have not received a fair hearing you should make your views known to the ASTM Committee on Standards, at the address shown below.

This standard is copyrighted by ASTM International, 100 Barr Harbor Drive, PO Box C700, West Conshohocken, PA 19428-2959, United States. Individual reprints (single or multiple copies) of this standard may be obtained by contacting ASTM at the above address or at 610-832-9585 (phone), 610-832-9555 (fax), or service@astm.org (e-mail); or through the ASTM website (www.astm.org).