



Standard Test Method for Resistance of Materials Used in Protective Clothing to Penetration by Synthetic Blood¹

This standard is issued under the fixed designation F 1670; the number immediately following the designation indicates the year of original adoption or, in the case of revision, the year of last revision. A number in parentheses indicates the year of last reapproval. A superscript epsilon (ϵ) indicates an editorial change since the last revision or reapproval.

INTRODUCTION

Workers, primarily those in the health care profession, involved in treating and caring for individuals injured or sick, can be exposed to biological liquids capable of transmitting disease. These diseases, which may be caused by a variety of microorganisms, can pose significant risks to life and health. This is especially true of blood-borne, Hepatitis [Hepatitis B Virus (HBV) and Hepatitis C Virus (HCV)] and Acquired Immune Deficiency Syndrome (AIDS) [Human Immunodeficiency Viruses (HIV)]. Since engineering controls can not eliminate all possible exposures, attention is placed on reducing the potential of direct skin contact through the use of protective clothing that resists penetration (29 CFR Part 1910.1030). This test method was developed to help assess the effectiveness of materials used in protective clothing for protecting the wearer against contact with body fluids that potentially contain blood-borne pathogens. Using synthetic blood, this test method is intended to identify protective clothing material candidates for further testing according to a more rigorous procedure involving a surrogate for blood-borne pathogens.

1. Scope

1.1 This test method is used to evaluate the resistance of materials used in protective clothing to penetration by synthetic blood under conditions of continuous liquid contact. Protective clothing *pass/fail* determinations are based on visual detection of synthetic blood penetration.

1.1.1 This test method is not always effective in testing protective clothing materials having thick, inner liners which readily absorb the synthetic blood.

1.2 This test method is a means for selecting protective clothing materials for subsequent testing with a more sophisticated barrier test as described in Test Method F 1671.

1.3 This test method does not apply to all forms or conditions of blood-borne pathogen exposure. Users of the test method must review modes for work/clothing exposure and assess the appropriateness of this test method for their specific application.

1.4 This test method addresses only the performance of materials or certain material constructions (for example, seams) used in protective clothing. This test method does not address the design, overall construction and components, or

interfaces of garments, or other factors which may affect the overall protection offered by the protective clothing.

1.5 The values in SI units or other units shall be regarded separately as standard. The values stated in each system must be used independently of the other, without combining values in any way.

1.6 *This standard does not purport to address all of the safety concerns, if any, associated with its use. It is the responsibility of the user of this standard to establish appropriate safety and health practices and determine the applicability of regulatory limitations prior to use.*

2. Referenced Documents

2.1 ASTM Standards:

D 1331 Test Methods for Surface and Interfacial Tension of Solutions of Surface-Active Agents²

D 1777 Test Method for Thickness of Textile Materials³

D 3776 Test Method for Mass Per Unit Area (Weight) of Woven Fabrics⁴

E 105 Practice for Probability Sampling of Materials⁵

¹ This test method is under the jurisdiction of ASTM Committee F23 on Protective Clothing and is the direct responsibility of Subcommittee F23.40 on Biological.

Current edition approved August 10, 2003. Published October 2003. Originally approved in 1995. Last previous edition approved in 1998 as F 1670 – 98.

² *Annual Book of ASTM Standards*, Vol 15.04.

³ *Annual Book of ASTM Standards*, Vol 07.01.

⁴ *Annual Book of ASTM Standards*, Vol 07.02.

⁵ *Annual Book of ASTM Standards*, Vol 14.02.

- E 171 Specification for Standard Atmospheres for Conditioning and Testing Flexible Barrier Materials⁶
- F 903 Test Method for Resistance of Materials Used in Protective Clothing to Penetration by Liquids⁷
- F 1671 Test Method for Resistance of Materials Used in Protective Clothing to Penetration by Blood-Borne Pathogens Using PHI-X174 Bacteriophage Penetration as a Test System⁷
- 2.2 *Military Standard*:⁸
- MIL-STD-105 Sampling Procedures and Tables for Inspection by Attributes
- 2.3 *ANSI/ASQC Standards*:⁹
- ANSI/ASQC Z1.4 Sampling Procedures and Tables for Inspection by Attributes
- 2.4 *ISO Standard*:¹⁰
- ISO 2859-1 Sampling Plans for Inspection by Attributes
- 2.5 *OSHA Standard*:¹¹
- 29 CFR Part 1910.1030 Occupational Exposure to Blood-borne Pathogens: Final Rule, *Federal Register*, Vol 56, No 235, Dec. 6, 1991, pp. 6175–64182.

3. Terminology

3.1 *blood-borne pathogen, n*—an infectious secreted or excreted bacterium, virus, or other disease inducing microbe carried in blood or other body fluids.

3.2 *body fluid, n*—any liquid produced (secreted or excreted) by the human body.

3.2.1 *Discussion*—In this test method, body fluids include those liquids potentially infected with blood-borne pathogens, including, but not limited to, blood, semen, vaginal secretions, cerebrospinal fluid, synovial fluid and peritoneal fluid, amniotic fluid, saliva in dental procedures, and any body fluid that is visibly contaminated with blood, and all body fluids in situations where it is difficult or impossible to differentiate between body fluids.¹¹

3.3 *body fluid simulant, n*—a liquid which is used to act as a model for human body fluids.

3.3.1 *Discussion*—In this test method, synthetic blood is used as a body fluid simulant.

3.4 *penetration, n*—the movement of matter through closures, porous materials, seams, and pinholes or other imperfections in protective clothing on a nonmolecular level.

3.4.1 *Discussion*—For this test method, the specific matter is synthetic blood.

3.4.2 *Discussion*—In this test method, the penetration liquid is synthetic blood.

3.5 *protective clothing, n*—any material or combination of materials used in an item of clothing for the purpose of isolating parts of the body from a potential hazard.

3.5.1 *Discussion*—The potential hazard is contact with blood.

3.6 *synthetic blood, n*—a mixture of a red dye/surfactant, thickening agent, and distilled water having a surface tension and viscosity representative of blood and some other body fluids, and the color of blood.

3.6.1 *Discussion*—The synthetic blood in this test method does not simulate all of the characteristics of real blood or body fluids, for example, polarity (a wetting characteristic), coagulation, content of cell matter.

4. Summary of Test Method

4.1 A specimen is subjected to a body fluid simulant (synthetic blood) for a specified time and pressure.

4.2 Visual observation is made to determine when, or if, penetration occurs.

4.3 Any evidence of synthetic blood penetration constitutes failure. Results are reported as *pass/fail*.

TABLE 1 Specimen Exposure Procedures

Procedure	Pressure/Time Sequence and Retaining Screen Options
A	0 kPa [0 psig] for 5 min, followed by 13.8 kPa [2 psig] for 1 min, followed by 0 kPa [0 psig] for 54 min. A retaining screen is not used to support the sample.
B	0 kPa [0 psig] for 5 min, followed by 13.8 kPa [2 psig] for 1 min, followed by 0 kPa [0 psig] for 54 min. A retaining screen is used to support the sample. The type must be specified in the report.

5. Significance and Use

5.1 This test method is based on Test Method F 903 for measuring resistance of chemical protective clothing materials to penetration by liquids. This test method is normally used to evaluate specimens from individual finished items of protective clothing and individual samples of materials that are candidates for items of protective clothing.

5.1.1 Finished items of protective clothing include gloves, arm shields, aprons, gowns, coveralls, hoods, and boots.

5.1.2 The phrase “specimens from finished items” encompasses seamed and other discontinuous regions as well as the usual continuous regions of protective clothing items.

5.2 Medical protective clothing materials are intended to be a barrier to blood, body fluids, and other potentially infectious materials. Many factors can affect the wetting and penetration characteristics of body fluids, such as surface tension, viscosity, and polarity of the fluid, as well as the structure and relative hydrophilicity or hydrophobicity of the materials. The surface tension range for blood and body fluids (excluding saliva) is approximately 0.042 to 0.060 N/m (1).¹² To help simulate the wetting characteristics of blood and body fluids, the surface tension of the synthetic blood is adjusted to approximate the lower end of this surface tension range. The resulting surface tension of the synthetic blood is approximately 0.042 ± 0.002 N/m.

¹² The boldface numbers in parentheses refer to the list of references at the end of this standard.

⁶ *Annual Book of ASTM Standards*, Vol 15.09.
⁷ *Annual Book of ASTM Standards*, Vol 11.03.
⁸ Available from Standardization Documents Order Desk, Bldg. 4 Section D, 700 Robbins Ave., Philadelphia, PA 19111-5094, Attn: NPODS.
⁹ Available from American Society for Quality Control, 611 E. Wisconsin Ave., Milwaukee, WI 53202.
¹⁰ Available from American National Standards Institute, 11 W. 42nd St., 13th Floor, New York, NY 10036.
¹¹ Available from Supt. of Documents, U.S. Government Printing Office, Washington, DC 20402.

5.3 The synthetic blood mixture is prepared with a red dye to aid in visual detection and a thickening agent to simulate the flow characteristics of blood.

5.4 Part of the protocol in Procedure A and B in Table 1 for exposing the protective clothing material specimens with synthetic blood involves pressurization of the test cell to 13.8 kPa [2 psig]. This hydrostatic pressure has been documented to discriminate between protective clothing material performance and correlate with visual penetration results that are obtained with a human factors validation (2). Some studies, however, suggest that mechanical pressures exceeding 345 kPa [50 psig] can occur during clinical use (3,4). Therefore, it is important to understand that this test method does not simulate all the physical stresses and pressures that are exerted on protective clothing garments during actual use. This test method is offered to identify those protective clothing materials that warrant further evaluation with a microbiological challenge.

5.5 Since this test method uses visual observation rather than analytical measurements for determination of penetration, use this test method as a preliminary evaluation for possible penetration of blood and other body fluids. Perform subsequent testing with a microbiological challenge and analytical technique using Test Method F 1671.

NOTE 1—No viral resistance claims can be made based on this test method as materials can pass the test method and fail Test Method F 1671.

5.6 Testing without considering degradation by physical, chemical, and thermal stresses which could negatively impact the performance of the protective barrier, could lead to a false sense of security. Consider tests which assess the impact of storage conditions and shelf life for disposable products, and the effects of laundering and sterilization for reusable products. The integrity of the protective barrier can also be compromised during use by such effects as flexing and abrasion (5). It is also possible that prewetting by contaminating materials such as alcohol and perspiration can also compromise the integrity of the protective barrier. If these conditions are of concern, evaluate the performance of protective clothing materials for synthetic blood penetration following an appropriate preconditioning technique representative of the expected conditions of use.

5.7 While this test method involves a qualitative determination of the protective clothing material resistance to penetration by synthetic blood under specific test conditions, it is possible to use this test method as a material quality control or assurance procedure.

5.7.1 If this procedure is used for quality control, perform proper statistical design and analysis of the data, when more than three specimens are tested. This type of analysis includes, but is not limited to, the number of individual specimens tested, the average percent passing and/or failing with a standard deviation. Data reported in this way helps to establish confidence limits concerning product performance. Examples of acceptable sampling plans are found in references such as MIL-STD-105, ANSI/ASQC Z1.4, and ISO 2859-1.

6. Apparatus

6.1 *Thickness Gage*, suitable for measuring thickness to the nearest 0.02 mm [or nearest 0.001 in.], in accordance with Test

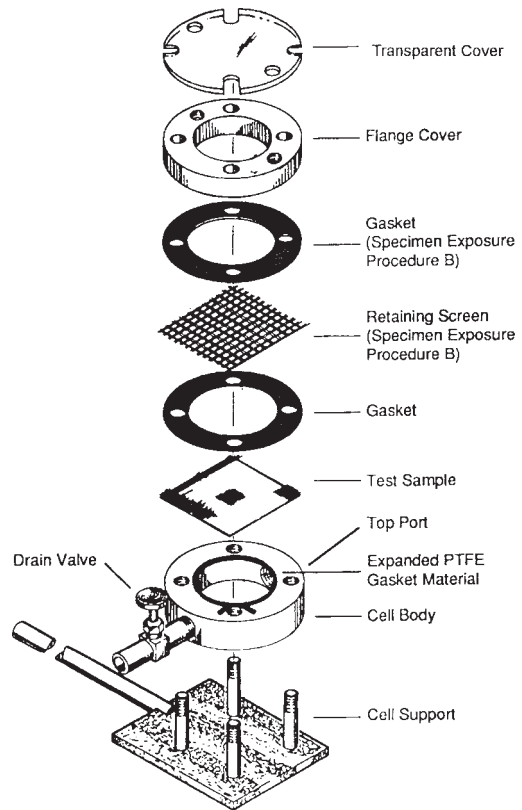

FIG. 1 Exploded View of the Penetration Test Cell with Retaining Screen

Method D 1777, used to determine the thickness of each protective clothing material specimen tested.

6.2 *Penetration Test Cell*,¹³ to restrain the specimen during contact with the pressurized test synthetic blood. In the test cell, the specimen acts as a partition separating synthetic blood from the view side of the test cell. It consists of a cell body that is fastened to a cell support. The cell body has a capacity of approximately 60 mL [2.0 oz] for synthetic blood. A flange cover, with an open area to allow visual observation and a transparent cover are included. The cell body has a top port for filling and a drain valve for draining the penetration test cell. Other items, such as a fitting to allow attachment of the air line to the top port in the cell body, gaskets, and the retaining screen are also required. Specifications for the penetration test cell are provided in Test Method F 903. A diagram of the test cell and apparatus are provided in Figs. 1 and 2, respectively.

6.3 *Retaining Screen*,¹⁴ a smooth finish plastic or metal square mesh screen meeting the following specifications used for Procedure B from Table 1:

% open area	>50
Should limit deflection of sample to	<= 5.0 mm [0.2 in.]

¹³ The penetration test apparatus is available from Wilson Road Machine Shop, 1170 Wilson Road, Rising Sun, MD 21911.

¹⁴ Acceptable retaining screen materials are 11 by 11 nylon screen (No. 9818T12), 14 by 14 polypropylene screen (No. 9275T11), and 13 by 13 polyester screen (No. 9218T12) from McMaster-Carr Supply Co., P.O. Box 4355, Chicago, IL 60680.

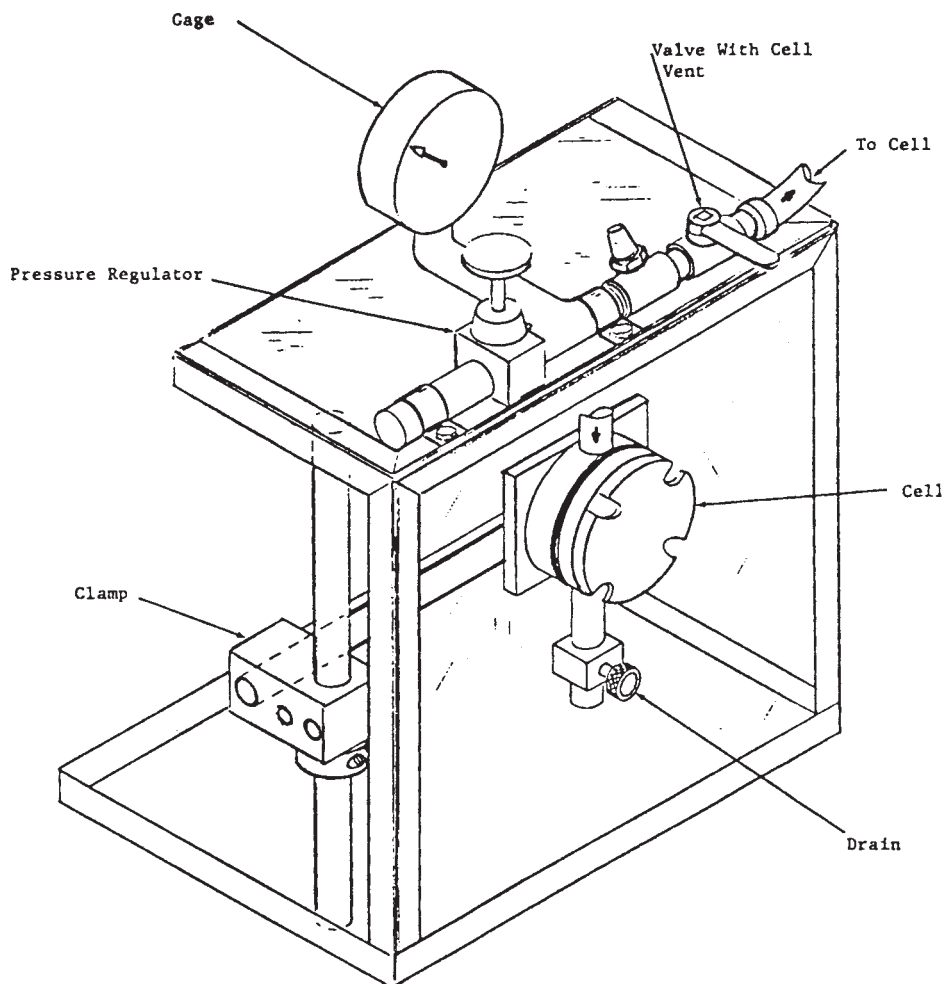

FIG. 2 Three Dimensional Side View of Apparatus

6.4 *Air Pressure Source*, capable of providing air at 13.8 ± 1.38 kPa [2.0 ± 0.2 psig].

6.5 *Stopwatch*, or electronic timer.

6.6 *Balance*, analytical, with precision of 0.001 g.

6.7 *Vessel*, graduated to measure water with a precision of 1 mL.

7. Reagents

7.1 *Synthetic Blood*.¹⁵ Prepare using following ingredients:

7.1.1 *High Performance Liquid Chromatography (HPLC)*, quality distilled water (1.0 L, pH 7.0 ± 0.5).

7.1.2 *Thickening Agent*,¹⁵ 25.0 g.

7.1.3 *Red Dye* containing colorant and surfactant, 10.0 g Ref (4).

7.1.4 To reduce biological contamination, boil the distilled water for 5 min and allow to cool to room temperature before mixing. Measure amount of water at 20°C ($\pm 1^\circ\text{C}$) after boiling.

7.1.5 Add the thickening agent to the distilled water and mix 45 min at room temperature on a magnetic stirring plate.

7.1.6 Add the red dye and mix 15 min more. **Warning**—The red dye will stain skin, clothes, and work surfaces.

7.1.7 Measure the corrected surface tension of the solution using Test Method D 1331. The expected value of the corrected surface tension is 0.042 ± 0.002 N/m. Do not use synthetic blood solutions unless within the specified range of surface tension.

7.1.7.1 Excessive oil in the red dye generally causes the unacceptable variations in synthetic blood surface tension. Remove excess oil from the red dye by mixing 25 g of red dye with 1 L of 90 % isopropanol, decant 80 % of the tainted alcohol, and discard or save for distillation. Pour dye-alcohol solution onto evaporation dish, spread thin, and cover with filter paper to allow residual alcohol to completely evaporate. The red dye is ready for use when dry.

7.1.7.2 Remove excess oil in the synthetic blood by allowing the mixture to settle for 24 h and then by carefully decanting the top 10 % of the mixture.

7.1.8 Store synthetic blood in a clear glass container at room temperature.

¹⁵ Prepared synthetic blood, meeting this specification, and small quantities of Direct Red 081, CI No. 28160 (Morfast Red 8BL) and small quantities of Acrysol G110, are available from Johnson, Moen and Co., 2505 Northridge Lane NE, Rochester, MN 55906.

7.1.9 Shake synthetic blood well before using to prevent its later separation.

7.1.10 Discard the solution if a gel-like precipitate forms.

8. Hazards

8.1 Before carrying out this test method, review safety precautions to provide full protection to all personnel. Either keep a transparent safety shield between the penetration cell and the observer, or alternatively, perform tests behind the window in a safety hood.

9. Test Specimens

9.1 Specimens selected from single material samples or individual protective clothing items consist of either a single layer or a composite of multiple layers that is representative of an actual protective clothing construction with all layers arranged in proper order.

9.1.1 If, in the design of an item of protective clothing, different materials or thicknesses of material are specified at different locations, select specimens from each location.

9.1.2 If, in the design of an item of protective clothing, seams are claimed to offer the same protection as the base materials, test additional specimens containing such seams.

9.2 Each material specimen to be tested shall have a minimum dimension of 70 mm [2.75 in.]. A 75 mm [3.0 in.] square is preferred.

9.3 Test three specimens taken at random from each material, composite, area (in the case of heterogeneous design), or other condition. If needed, generate random specimens as described in Practice E 105.

9.4 It is possible that protective clothing materials incorporating an impervious layer between two fabric layers are sensitive to false positive failures by wicking at the edges. Seal the edges of the test specimens to prevent *wicking* modes of failure. Seal test specimens with an adhesive, parafilm, paraffin wax, or adhesive backed foam prior to testing.

9.4.1 Seal only the edges of the test specimens, leaving the center 57 mm [2.26 in.] area open for testing. Do not allow sealants to intrude, block, or occlude the structure of the test specimen in the test area, as this may compromise the test procedure. Choose sealants and sealing methods that are compatible with the protective clothing materials.

10. Conditioning

10.1 Condition each protective clothing specimen for a minimum of 24 h by exposure to a temperature of $21 \pm 5^\circ\text{C}$ [$70 \pm 10^\circ\text{F}$] and a relative humidity of 30 to 80 % in accordance with Specification E 171.

10.2 If warranted, use other preconditioning options to assess possible degradation mechanisms of protective clothing (5.6).

11. Procedure

11.1 Measure the thickness of each specimen to the nearest 0.02 mm [or nearest 0.001 in.] in accordance with Test Method D 1777.

11.2 Measure the weight of each specimen to the nearest 10 g/m² [0.1 oz/yd²] in accordance with Test Method D 3776.

11.3 Place a small droplet of the synthetic blood on the normal inside surface of an extra piece of the material to be tested. The droplet must remain easily visible to ensure that a droplet that penetrates the material will be seen. If not, use talcum powder on the normal inside surface of the fabric to enhance droplet visibility.

11.4 When distortion of the test material is suspected of causing failure with Specimen Exposure Procedure A of this test method, use Specimen Procedure B. Specimen Exposure B involves the use of a retaining screen which is used when support of extensible or elastomeric materials is required.

11.4.1 Select Specimen Exposure Procedure A or B from Table 1.

11.5 With the cell placed horizontally on the lab bench, insert the specimen in the penetration cell with the normal outside surface of the fabric toward the cell reservoir which will be filled with synthetic blood.

11.5.1 Assemble the components of the cell as follows: place gaskets between the penetration cell and test specimen, the specimen and the retaining screen (if used), and the retaining screen and the flange cover as shown in Fig. 1. Close the penetration cell by putting on the flange cover and transparent cover. Polytetrafluoroethylene (PTFE) gasket material is recommended for use between the cell body and the test specimen to help prevent leakage.¹⁶

NOTE 2—Clear plastic film is an acceptable substitute for the transparent cover.

11.6 Torque the bolts in the test cell to 13.6 N·m [120 in.-lb] each.

11.7 Mount the penetration cell in the test apparatus in a vertical position as shown in Fig. 2 (drain valve down) but do not connect the air line to the cell.

11.8 Close the drain valve.

11.9 Carefully fill the chamber of the penetration cell through the top port with approximately 60 mL of synthetic blood (a syringe or funnel is useful). If liquid penetrates through the test specimen at anytime during the test, terminate the test.

11.10 Observe for 5 min.

11.11 Connect the air line to the penetration cell.

11.12 Supply pressurized air through the top port of the penetration cell. Slowly raise the pressure to 13.8 kPa [2.0 psig] at the rate of no more than 3.5 kPa/s [0.5 psig/s].

11.13 Hold the pressure constant at 13.8 ± 1.38 kPa [2.0 ± 0.2 psig], for 1 min and monitor the viewing surface of the specimen for the appearance of liquid.

11.14 Turn off the pressure and open the cell valve to the vent position.

11.15 If liquid penetration is not visible at this point, observe the specimen again after an additional 54 min.

11.16 At the end of the time period, open the drain valve and drain the penetration test cell of the synthetic blood. Flush the test cell with an appropriate wash liquid to remove any traces of the synthetic blood. Remove the specimen and gasket

¹⁶ PTFE gasket material is available from W. L. Gore and Associates, Inc., Industrial Sealant Group, Elkton, MD 21921.

from the cell. Clean any external parts of the test cell which may have been touched by synthetic blood.

11.17 Note whether a droplet of the synthetic blood appears or other evidence of wetness on the viewing side of the specimen is observed or both. If elected, record the time of failure.

NOTE 3—Some materials may appear to be wet due to the optical properties of an outer film layer. Wetness can be confirmed by blotting the specimen with an absorbent material during the test.

11.18 Test the remaining specimens.

12. Report

12.1 State that the test was conducted as directed in Test Method F 1670, Specimen Exposure Procedure A or B.

12.2 Describe the material tested and the method sampling used.

12.2.1 Report if the material was taken from roll goods or garments. Report the type (fiber and coating compositions), supplier, lot number, and date of receipt of the material tested. If the material was taken from garments, report under subheadings for each material, composite, type of seam, or other conditions tested, and its position on the garment.

12.3 Report the following information:

12.3.1 Thickness of each material specimen and the average thickness of the materials tested,

12.3.2 Weight of each material specimen and the average weight of the materials tested,

12.3.3 A description of any technique used to enhance visual detection of synthetic blood penetration,

12.3.4 The type and specification for the support screen, if used, and

12.3.5 The *pass* or *fail* for each specimen.

13. Precision and Bias

13.1 *Precision*—The precision of Procedures A and B from Table 1 of this test method was determined by interlaboratory testing involving six laboratories using three materials, one negative control, and one positive control. The results of these interlaboratory tests showed total agreement for all materials and material replicates among all participating laboratories. The results of these interlaboratory tests are provided in Research Report.¹⁷

13.2 *Bias*—The procedures in this test method for measuring synthetic blood penetration have no bias because results are determined as either *pass* or *fail*.

14. Keywords

14.1 blood; blood-borne pathogens; body fluids; penetration; protective clothing; synthetic blood

¹⁷ Available from ASTM Headquarters. Request RR:F23-1002.

REFERENCES

- (1) Lentner, C., Ed., *Geigy Scientific Tables*, Volume 1—Units of Measurement, Body Fluids, Composition of Blood, Hematology, Somatometric Data, 1984, Medical Education Division, Ciba-Geigy Corporation, West Caldwell, NJ.
- (2) McCullough, E. A. and Schoenberger, L. K., “Liquid Barrier Properties of Nine Surgical Gown Fabrics,” *INDA Journal of Nonwovens Research*, Vol 3, No. 3, Summer 1991, pp. 14–20.
- (3) Smith, J. W. and Nichols, R. L., “Barrier Efficiency of Surgical Gowns,” *Archives of Surgery*, Vol 126, June 1991, pp. 756–762.
- (4) Altman, K. W., et al, “Transmural Surgical Gown Pressure Measurements in the Operating Theater,” *American Journal of Infection Control*, Vol 19, 1991, pp. 147–155.
- (5) Telford, G. L. and Quebbeman, E. J., “Assessing the Risk of Blood Exposure in the Operating Room,” *American Journal of Infection Control*, Vol 21, No. 6, December 1993, pp. 351–356.

ASTM International takes no position respecting the validity of any patent rights asserted in connection with any item mentioned in this standard. Users of this standard are expressly advised that determination of the validity of any such patent rights, and the risk of infringement of such rights, are entirely their own responsibility.

This standard is subject to revision at any time by the responsible technical committee and must be reviewed every five years and if not revised, either reapproved or withdrawn. Your comments are invited either for revision of this standard or for additional standards and should be addressed to ASTM International Headquarters. Your comments will receive careful consideration at a meeting of the responsible technical committee, which you may attend. If you feel that your comments have not received a fair hearing you should make your views known to the ASTM Committee on Standards, at the address shown below.

This standard is copyrighted by ASTM International, 100 Barr Harbor Drive, PO Box C700, West Conshohocken, PA 19428-2959, United States. Individual reprints (single or multiple copies) of this standard may be obtained by contacting ASTM at the above address or at 610-832-9585 (phone), 610-832-9555 (fax), or service@astm.org (e-mail); or through the ASTM website (www.astm.org).