



Designation: F 1819 – 03<sup>4</sup>

## Standard Test Method for Resistance of Materials Used in Protective Clothing to Penetration by Synthetic Blood Using a Mechanical Pressure Technique<sup>1</sup>

This standard is issued under the fixed designation F 1819; the number immediately following the designation indicates the year of original adoption or, in the case of revision, the year of last revision. A number in parentheses indicates the year of last reapproval. A superscript epsilon ( $\epsilon$ ) indicates an editorial change since the last revision or reapproval.

### INTRODUCTION

Workers, primarily those in the health care profession, involved in treating and caring for individuals injured or sick, can be exposed to biological liquids capable of transmitting disease. These diseases, which may be caused by a variety of microorganisms, can pose significant risks to life and health. This is especially true of blood-borne viruses which cause Hepatitis (Hepatitis B Virus (HBV) and Hepatitis C Virus (HCV)) and Acquired Immune Deficiency Syndrome (AIDS) (Human Immunodeficiency Viruses (HIV)). Since engineering controls cannot eliminate all possible exposures, attention is placed on reducing the potential for direct skin contact through the use of protective clothing that resists penetration (29 CFR Part 1910.1030). This test method was developed to help assess the effectiveness of materials used in protective clothing for protecting the wearer against contact with body fluids that potentially contain blood-borne pathogens. Using synthetic blood, this test method is intended to determine the amount of mechanical pressure that will cause penetration of a liquid through a material used in protective clothing.

### 1. Scope

1.1 This test method is used to evaluate the resistance of materials used in protective clothing to synthetic blood under the conditions of liquid contact and increasing direct mechanical pressure. The penetration resistance of protective clothing is based on visual detection of synthetic blood penetration at a specific applied mechanical pressure.

1.2 This test method does not apply to all forms or conditions of blood-borne pathogen exposure. Users of the test method must review modes for work/clothing exposure and assess the appropriateness of this test method for their specific application.

1.3 This test method addresses only the performance of materials or certain material constructions (for example, seams) used in protective clothing. This test method does not address the design, overall construction, components, or interfaces of garments, or other factors which may affect the overall protection offered by the protective clothing.

1.4 The values in SI units or in other units shall be regarded separately as standard. The values stated in each system must be used independently of the other, without combining values in any way.

1.5 *This standard does not purport to address all of the safety concerns, if any, associated with its use. It is the responsibility of the user of this standard to establish appropriate safety and health practices and determine the applicability of regulatory limitations prior to use.*

---

<sup>1</sup> This test method is under the jurisdiction of ASTM Committee F23 on Protective Clothing and is the direct responsibility of Subcommittee F23.40 on Biological . Current edition approved August 10, 2003; March 1, 2004. Published October 2003; April 2004. Originally approved in 1997. Last previous edition approved in 1998, 2003 as F 1819-98/03.

## 2. Referenced Documents

### 2.1 *ASTM Standards:*<sup>2</sup>

- D 1331 Test Methods for Surface and Interfacial Tension in Solutions of Surface-Active Agents
- D 1777 Test Method for Measuring Thickness of Textile Materials
- D 3776 Test Method for Mass Per Unit Area (Weight) of Fabric
- E 105 Practice for Probability Sampling of Materials
- E 171 Specifications for Standard Atmospheres for Conditioning and Testing Materials
- E 691 Practice for Conducting an Interlaboratory Study to Determine the Precision of a Test Method
- F 1494 Terminology Relating to Protective Clothing
- F 1670 Test Method for Resistance of Materials Used in Protective Clothing to Penetration by Synthetic Blood
- F 1671 Test Method for Resistance of Materials Used in Protective Clothing to Penetration by Blood-Borne Pathogens Using Phi-X174 Bacteriophage Penetration as a Test System

### 2.2 *ANSI/ASQC Standards*<sup>3</sup>

- ANSI/ASQC Z1.4 Sampling Procedures and Tables for Inspection by Attributes

### 2.3 *ISO Standard*<sup>4</sup>

- ISO 2859-1 Sampling Plans for Inspection by Attributes

### 2.4 *Military Standard*<sup>5</sup>

- MIL-STD-105 Sampling Procedures and Tables for Inspection by Attributes

### 2.5 *OSHA Standard*<sup>6</sup>

- CFR Part 1910.1030 Occupational Exposure to Blood-borne Pathogens: Final Rule, *Federal Register*, Vol 56, No 235, Dec. 6, 1991, pp. 64175–64182.

## 3. Terminology

### 3.1 *Definitions:*

3.1.1 *blood-borne pathogen, n*—an infectious bacterium, virus, or other disease inducing microbe carried in blood or other potentially infectious body fluids.

3.1.2 *body fluid, n*—any liquid produced, secreted, or excreted by the human body.

3.1.2.1 *Discussion*—In this test method, body fluids include those liquids potentially infected with blood-borne pathogens, including, but not limited to, blood, semen, vaginal secretions, cerebrospinal fluid, synovial fluid and peritoneal fluid, amniotic fluid, saliva in dental procedures, and any body fluid that is visibly contaminated with blood, and all body fluids in situations where it is difficult or impossible to differentiate between body fluids (see 29 CFR Part 1910.1030).

3.1.3 *body fluid simulant, n*—a liquid which is used to act as a model for human body fluids.

3.1.4 *hydrostatic pressure, n*—the force exerted by a static liquid **(1)**<sup>7</sup>

3.1.5 *mechanical pressure, n*—the force exerted by one solid object upon another that it is touching. **(1)**

3.1.6 *penetration, n*—the movement of matter through closures, porous materials, seams, and pinholes or other imperfections in protective clothing on a nonmolecular level.

3.1.6.1 *Discussion*—For this test method, the specific matter is synthetic blood.

3.1.7 *protective clothing, n*—any material or combination of materials used in an item of clothing for the purpose of isolating parts of the body from a potential hazard.

3.1.7.1 *Discussion*—In this test method, the potential hazard of contact with blood or other body fluids is simulated.

3.1.8 *synthetic blood, n*—a mixture of a red dye/surfactant, thickening agent, and distilled water having a surface tension and viscosity representative of blood and some other body fluids, and the color of blood.

3.1.8.1 *Discussion*—The synthetic blood in this test method does not simulate all of the characteristics of real blood or body fluids, for example, polarity (a wetting characteristic), coagulation, content of cell matter.

3.1.9 For definitions of other protective clothing-related terms used in this test method, refer to Terminology F 1494.

## 4. Summary of Test Method

4.1 Using a special test apparatus, a specimen is contacted with synthetic blood under a continuously increasing mechanical

<sup>2</sup> For referenced ASTM standards, visit the ASTM website, [www.astm.org](http://www.astm.org), or contact ASTM Customer Service at [service@astm.org](mailto:service@astm.org). For *Annual Book of ASTM Standards*, Vol. 15-04 volume information, refer to the standard's Document Summary page on the ASTM website.

*Annual Book of ASTM Standards*, Vol. 07-01

<sup>3</sup> Available from American Society for Quality (ASQ), 600 N. Plankinton Ave., Milwaukee, WI 53203.

*Annual Book of ASTM*

<sup>4</sup> Available from American National Standards Institute (ANSI), 25 W. 43rd St., 4th Floor, New York, NY 10036.

*Annual Book of ASTM Standards*, Vol. 14-02

<sup>5</sup> Available from Standardization Documents Order Desk, Bldg. 4, Section D, 700 Robbins Ave., Philadelphia, PA 19111-5094, Attn: NPODS.

*Annual Book*

<sup>6</sup> Available from Supt. of ASTM Standards, Vol. 15-09 Documents, U.S. Government Printing Office, Washington, DC 20402.

*Annual Book*

<sup>7</sup> The boldface numbers in parentheses refer to the list of ASTM Standards, Vol. 11-03 references at the end of this standard.

pressure until the synthetic blood penetrates the specimen or a load of 90.7 kg [200 lbs] is applied to a 57.2 mm [2.25 in.] diameter portion of the specimen achieving a pressure on the tested specimen of 345 kPa [50 psig].

4.2 The specimen's non-contact side is observed to determine if visual penetration occurs, and if so, at what mechanical pressure the penetration occurs.

4.3 In conducting a test, the cover plate containing a test head is locked on the two side supports of the base plate of the test apparatus, the multi-position switch is turned to the *manual up* position, and the test button on top of the control box is held down until visible penetration of the test specimen by synthetic blood is observed through the circular test head. Releasing the button stops the drive motor, and the penetration pressure is shown digitally on the display unit and recorded by the technician.

## 5. Significance and Use

5.1 This test method was modeled after a procedure commonly known as the Elbow Lean Test.<sup>8</sup> The Elbow Lean Test involves the application of synthetic blood to an ink pad, placement of sample fabric over the blood soaked pad, placement of a blotter over the sample fabric, and applying elbow or fingertip pressure on top of the blotter. The blotter is then examined for staining as evidence of blood penetration. This test method provides similar procedures which standardize the test equipment and application of pressure through an adopted methodology.

5.2 This test method is intended to simulate actual use conditions wherein areas of the health care worker's protective clothing are soaked with blood and compressed between the patient's body and that of the health care worker, or similarly between the health care worker and instruments. In both cases, unconfined blood can move away from the pressure point taking the path of least resistance rather than being contained as in Test Methods F 1670 and F 1671.

5.3 This test method uses predominately mechanical pressure as opposed to contained, hydrostatic pressure to demonstrate liquid penetration resistance (1,2) . It simulates actual use conditions with a single insult where free flowing liquids on in which the outer surfaces of a protective clothing item are momentarily pressurized against the item compressed at a steady rate by the wearer's body against a wet surface. This steady rate of compression represents one potential use scenario. Other scenarios may result in a wide variety of pressure ramp rates and profiles that are not simulated by the test apparatus.

5.4 Because this test method provides quantitative results, it is useful for discriminating differences in the liquid barrier performance of protective clothing materials. This test method can be used for measuring differences in the penetration pressure for protective clothing materials which do not pass Test Method F 1670.

5.5 This test method is normally used to evaluate specimens from individual finished items of protective clothing and individual samples of materials that are candidates for items of protective clothing.

5.5.1 Finished items of protective clothing include gloves, arm shields, aprons, gowns, hoods, and boots.

5.5.2 The phrase *specimens from finished items* encompasses seamed and other discontinuous regions as well as the usual continuous regions of protective clothing items.

5.6 Medical protective clothing materials are intended to be a barrier to blood, body fluids, and other potentially infectious materials. Many factors can affect the wetting and penetration characteristics of body fluids, such as surface tension, viscosity, and polarity of the fluid, as well as the structure and relative hydrophilicity or hydrophobicity of the materials. The synthetic blood solution may exhibit different wetting behavior on fabrics or films with identical structures but different chemical compositions. The surface tension range for blood and body fluids (excluding saliva) is approximately 0.042 to 0.060 N/m (3) . To help simulate the wetting characteristics of blood and body fluids, the surface tension of the synthetic blood is adjusted to approximate the lower end of this surface tension range. The resulting surface tension of the synthetic blood is 0.042 ± 0.002 N/m.

5.7 The synthetic blood mixture is prepared with a red dye to aid in visual detection and a thickening agent to simulate the flow characteristics of blood. The synthetic blood may not duplicate the polarity, and thus wetting behavior and subsequent penetration, of real blood and other body fluids through protective clothing materials.

5.8 It is known that body fluids penetrating protective clothing materials are likely to carry microbiological contaminants; however, visual detection methods are not sensitive enough to detect minute amounts of liquid containing microorganisms (4,5,6). No viral resistance claims can be made based on this test method as materials can pass this test method and fail Test Method F 1671.

5.9 Part of the protocol for exposing the protective clothing material specimens to synthetic blood involves applying mechanical pressure up to 345 kPa [50 psig]. This mechanical pressure has been documented to discriminate ~~between~~ protective clothing material performance and correlate with visual penetration results that are obtained with one type of human factors validation, the Elbow Lean Test.<sup>1</sup> The Elbow Lean Test does not simulate all of the possible types of clinical exposure as there is one contact with liquid under high mechanical pressure for a short duration. Some studies suggest that mechanical pressures exceeding 345 kPa [50 psig] can occur during clinical use (8,9) .

NOTE 1—The mechanical pressure tester can be adjusted to evaluate materials at higher pressures.

5.10 Testing prior to degradation by physical, chemical, and thermal stresses which could negatively impact the performance of the protective barrier, could lead to a false sense of security. Consider tests which assess the impact of storage conditions and

<sup>8</sup> Available from American Society for Quality (ASQ), 600 N. Plankinton Ave., Milwaukee, WI 53203.

<sup>9</sup> Originally developed by W.L.Gore and Assoc., Inc., Elkton, MD 21921.

shelf life for disposable products, and the effects of laundering and sterilization for reusable products. The integrity of the protective clothing can also be compromised during use by such effects as flexing and abrasion (10). It is also possible that prewetting by contaminants such as alcohol and perspiration can compromise the integrity of the protective clothing. Furthermore, high relative humidity may also affect the resistance of materials used in protective clothing to penetration by blood and other body fluids. If these conditions are of concern, evaluate the performance of protective clothing for synthetic blood penetration following an appropriate pretreatment technique representative of the expected conditions of use.

5.11 This test method involves a quantitative determination of a protective clothing penetration resistance to synthetic blood under specific test conditions. It can also be used as a qualitative method for comparing the penetration resistance characteristics of similar materials and as a material quality control or assurance procedure.

5.12 If this test method is used for quality control, perform proper statistical design and analysis of larger data sets where more than three specimens are tested. This type of analysis includes, but is not limited to, reporting the number of individual specimens tested and the average penetration pressure of specimens with a standard deviation. Data reported in this way helps establish confidence limits concerning product performance. Examples of acceptable sampling plans are found in references such as MIL-STD-105, ANSI/ASQC Z1.4, and ISO 2859-1.

5.13 In the case of a dispute arising from differences in reported results when using this test method for acceptance testing of commercial shipments, the purchaser and the supplier should conduct comparative tests to determine if there is a statistical bias between their laboratories. Competent statistical assistance is recommended for investigation of bias. As a minimum, the two parties should take a group of test specimens which are as homogeneous as possible and which are from a lot of the product of the type in question. The test specimens should then be randomly assigned in equal numbers to each laboratory for testing. The average results from the two laboratories should be compared using a non-parametric test for unpaired data and an acceptable probability level chosen by the two parties before testing is begun. If a bias is found, either its cause must be found and corrected or the purchaser and the supplier must agree to interpret future test results with consideration to the known bias.

## 6. Apparatus

6.1 *Thickness Gage*, suitable for measuring thickness to the nearest 0.02 mm [0.001 in.], in accordance with Test Method D 1777, used to determine the thickness of each protective clothing material specimen tested.

6.2 *Mechanical Penetration Tester*,<sup>9,10</sup> shown in Fig. 1, consisting of a base plate, a variable speed drive motor, a belted gear driven screw, a lower platform, load cell, upper platform, cover plate, control box, and display unit. The driver motor is connected to the screw through a belted gear. The screw is then connected to the underside of the lower platform which moves up and down, in tubular sleeves when the screw turns at a rate of 827.5 RPM which corresponds to a platform vertical speed of  $\pm 0.20$  mm/min [ $0.479 \pm 0.008$  in./min]. The top of the lower platform is fastened to the bottom of the load cell, and the top of the load cell is fastened to the underside of the upper platform. The upper platform provides a location for resting the petri dish containing a foam pad and synthetic blood and the specimen. The control box has a test button and multi-position switch with settings for *down*, *off*, *auto up*, and *manual up*. A display unit indicates the load (weight) from the load cell in lbs.

NOTE 2—If desired the mechanical pressure tester can rate of compression may be adjusted to achieve lower or higher application speeds. A separate control is provided for this purpose, or lower. This may slightly alter the rate of pressure change in the low pressure region of the pressure profile (during sponge compression), but will not significantly alter the rate of pressure change in the high pressure region of the pressure profile (above sponge compression).

6.2.1 Since small differences in the screw and control box may exist between different mechanical pressure testers, ensure that the platform moves at a speed of  $12.17 \pm 0.20$  mm/min [ $0.479 \pm 0.008$  in/min].

6.3 *Circular Test Head*, transparent, with a diameter of 57.2 mm [2.25 in.] and a surface area of 2570 mm<sup>2</sup> [3.976 in.<sup>2</sup>].

6.4 *Petri Dish*, plastic, 93 by 93 by 15 mm.

6.5 *Foam Pad*, polyester, 0.64 mm [0.25 in.] thick, non-reticulated, with 90 pores/in., a compression ration of 3:1, and free of surfactants and other additives, cut to fit the petri dish dimensions.<sup>10,11</sup>

6.6 *Rod*, poly (methyl methacrylate) (PMMA), approximately 2.5 mm in diameter by 300 mm in length, for saturating the foam pads with synthetic blood and removing air bubbles.

6.7 *Bubble Level*, for leveling instrument.

6.8 *Ruler*, graduated in 1 mm [0.05 in.] increments, for measuring the height of the synthetic blood in the petri dish.

<sup>9</sup> Apparatus available from American National Standards Institute (ANSI), 25 W. 43rd St., 4th Floor, New York, NY 10036; Johnson, Moen & Co., 2505 Northridge Lane NE, Rochester, MN 55906.

<sup>10</sup> Available from Standardization Documents Order Desk, Bldg. 4, Section D, 700 Robbins Ave., Philadelphia, PA 19111-5094, Attn: NPODS.

<sup>10</sup> The supplier named is the sole source of supply known to the committee at this time. If you are aware of alternative suppliers, please provide this information to ASTM Headquarters. Your comments will receive careful consideration at a meeting of the responsible technical committee which you may attend.

<sup>11</sup> A suitable pad is a Foamex Product #3-900C custom felt, polyester, beige color foam for medical end use. Foam pads are available from Supt. of Documents, U.S. Government Printing Office, Washington, DC 20402; Johnson, Moen & Co., 2505 Northridge Lane NE, Rochester, MN 55906.

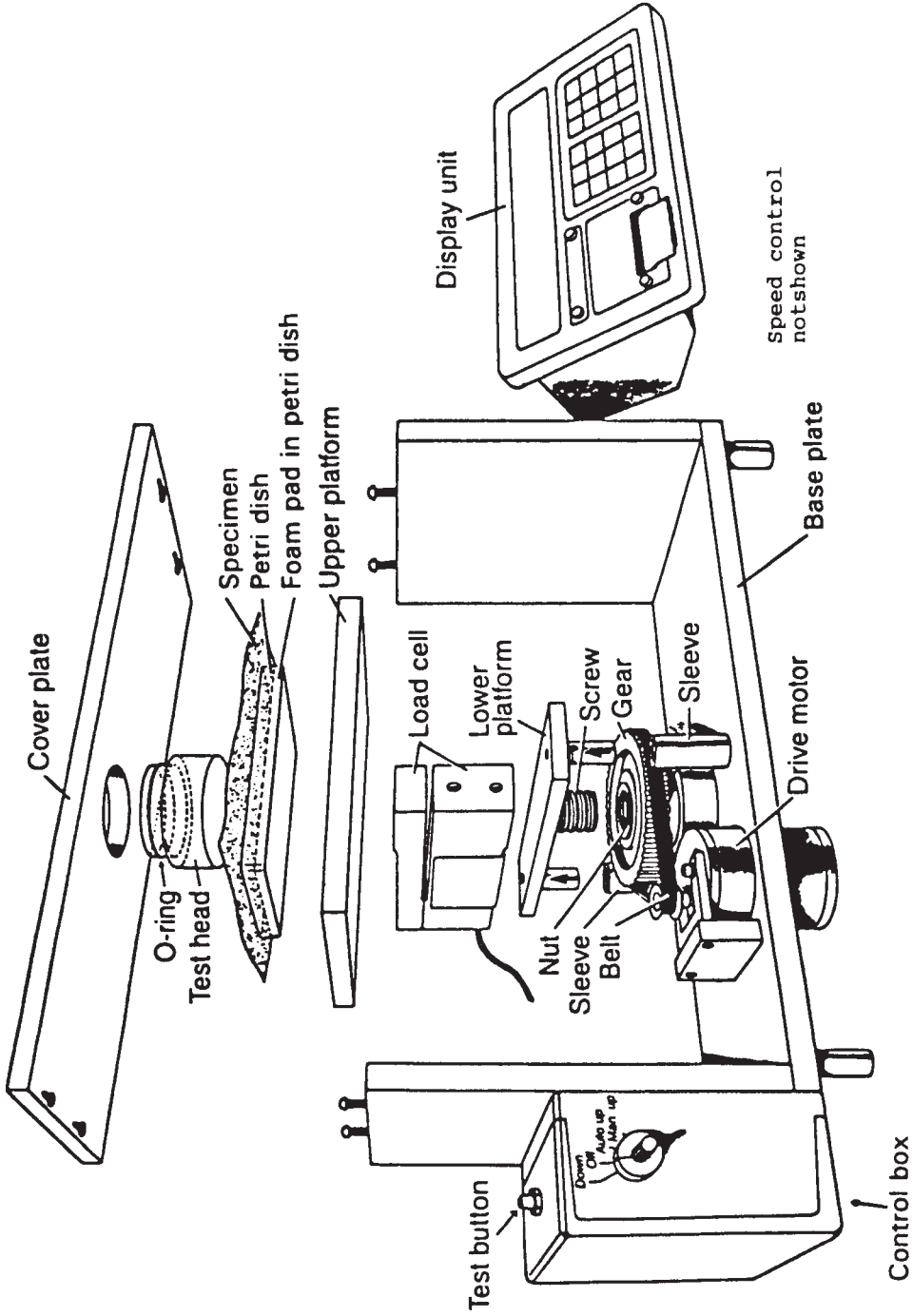

FIG. 1 Mechanical Penetration Tester



## 7. Reagents

7.1 *Synthetic Blood*<sup>10,12</sup>—If synthetic blood is not purchased, prepare using following ingredients:

7.1.1 *High Performance Liquid Chromatography (HPLC)*, quality distilled water (1.0 L, pH 7.0 ± 0.5)

7.1.2 *Thickening agent*,<sup>12,10</sup> 25.0 g.

7.1.3 *Red dye*<sup>10,12</sup> containing colorant and surfactant, 10.0 g.

7.1.4 To reduce biological contamination, boil the distilled water for 5 min and allow to cool to room temperature before mixing. Measure amount of distilled water at 20°C (±1°C) after boiling.

7.1.5 Add the thickening agent to the distilled water and mix 45 min at room temperature on a magnetic stirring plate.

7.1.6 Add the red dye and mix 1 h or more.

NOTE 3—The red dye will stain skin, clothes, and work surfaces.

7.1.7 Determine the corrected surface tension of the solution using Test Method D 1331. The expected value of the corrected surface tension is 0.042 ± 0.002 N/m. Do not use synthetic blood solutions unless within the specified range of surface tension.

7.1.7.1 The amount of surfactant in the red dye may vary significantly causing unacceptable surface tension variability from batch to batch. If the corrected surface tension is too high, discard the batch of prepared synthetic blood. If the corrected surface tension is too low, remove excess surfactant from the red dye by mixing 25 g of red dye with 1 L of 90 % isopropanol, decant 80 % of the tainted alcohol, and discard or save for distillation. Pour dye - alcohol solution into an evaporation dish, spread thin, and cover with filter paper to allow residual alcohol to completely evaporate. The red dye is ready for use when dry.

7.1.7.2 Remove excess surfactant from the synthetic blood by allowing the mixture to settle for 24 h and then by carefully decanting the top 10 % of the mixture.

7.1.8 Store synthetic blood in a clear glass container at room temperature.

7.1.9 Shake synthetic blood well before using to prevent its separation.

7.1.10 Discard the solution if a gel-like precipitate forms.

7.2 *Isopropanol*, laboratory grade, for cleaning of circular test head.

## 8. Hazards

8.1 Because the synthetic blood readily stains clothing, wear a laboratory coat or similar cover during testing.

8.2 Keep fingers and hands away from the gears, drive belt, and test head when the tester motor is running. Place a safety shield or panel between the apparatus and the operator to minimize this hazard. **Warning**— Ensure that the cover plate is properly secured before operating the apparatus.

## 9. Test Specimen

9.1 Specimens selected from single material samples or individual protective clothing items consist of either a single layer or a composite of multiple layers that is representative of an actual protective clothing construction with all layers arranged in proper order.

9.1.1 If, in the design of an item of protective clothing, different materials or thicknesses of material are specified at different locations, select specimens from each location.

9.1.2 If, in the design of an item of protective clothing, seams are claimed to offer the same protection as the base materials, test additional specimens containing such seams.

9.2 Use square material specimens having minimum dimensions of 140 by 140 mm [5.5 by 5.5 in.]. An entire finished garment can be used and various locations on the surface can be tested without damage to the garment except for the red dye stain.

9.3 Test five randomly selected specimens for each material, composite, area (in the case of heterogeneous design), or other condition. Random specimens may be generated as described in Practice E 105.

9.4 If warranted, use other pretreatment options (such as prewetting) to assess possible degradation mechanisms of protective clothing (5.10).

## 10. Conditioning

10.1 Condition each specimen for a minimum of 24 h by exposure to a temperature of 21 ± 5°C [70 ± 10°F] and a relative humidity of 30 to 80 % as described in Specification E 171.

## 11. Procedure

11.1 Measure the thickness of each specimen to nearest 0.02 mm [0.001 in.] in accordance with Test Method D 1777.

11.2 Measure the weight of each specimen to the nearest 10 g/m<sup>2</sup>[or nearest 0.1 oz/yd<sup>2</sup>] in accordance with Test Method D 3776.

11.3 Connect load cell plug to external I/O connector in the middle back of the display unit.

<sup>12</sup> The boldface numbers in parentheses refer to the list of references at the end of

<sup>12</sup> Prepared synthetic blood meeting this specification, small quantities of Direct Red 081, CI #28160 (Morfast Red 8BL), and Acrysol G110 are available from Johnson, Moen & Co., 2505 Northridge Lane NE, Rochester, MN 55906.

11.4 Connect the motor cable to the load cell on the left of the back of the display unit.

11.5 Connect the power cord on the right of the back of the display unit and the other end into line voltage (wall socket).

11.6 Place the display unit by primary apparatus on a box so that the digital display is behind and even with the top of the mechanical pressure tester and can be seen easily.

11.7 Make sure the upper platform is in its lowest position. Turn switch to *Down* to lower the upper platform.

11.8 Remove the cover plate containing the circular test head and place it upside down on the work surface (that is, with circular test head facing up).

11.9 Place bubble level in center of upper platform. Place layers of cardboard under the appropriate *legs* of the mechanical pressure tester to level it, if necessary. Center the bubble within the black circle of the bubble level.

11.10 Shake the synthetic blood well before each use. With the foam pad in place within the petri dishes, fill a petri dish with  $33 \pm 1$  mL synthetic blood. Use the flat end of a plexiglass rod to aid in the absorption by compressing the entire surface of the foam pad when adding the synthetic blood.

NOTE 4—The foam pad will absorb the liquid slowly and will also swell when wetted.

11.11 Cover the petri dish and allow it to set for 2 h. Apply a load of 15.876 kg [35 lb] for a pressure of 60.86 kPa [8.8 psi] to the center of the foam pad with the circular test head (see 11.14–11.17). Wait at least 5 min and repeat the pressure application. Using a ruler, ensure that a layer of blood approximately 1 mm [0.04 in.] thick covers the foam pad.

NOTE 5—This preparation procedure helps to promote absorption of the synthetic blood into the foam pad and to eliminate air bubbles.

11.12 Prepare 1 petri dish for each replication of the test (that is, five petri dishes for five specimens cut from a material. Number the petri dishes 1 to 5. Keep the petri dishes covered when they are not being in a test.

11.12.1 Use the petri dishes the same day they are saturated with the synthetic blood. If a large number of different materials are being tested in a set, it may not be possible to complete five replicates in one day. Therefore, prepare the petri dishes at different times, according to the testing schedule.

11.13 Place the first petri dish filled with synthetic blood in the center of the upper platform.

11.14 Place the specimen to be tested over the petri dish with outside surface facing down toward the foam pad. During this step, do not let the specimen touch the layer of synthetic blood on top of the foam pad.

11.15 Zero the pressure reading on the display unit by pressing the *zero* button on the display unit.

11.16 Place the top cover on the apparatus and secure by locking the screws. Point the circular test head down above the specimen, synthetic blood, and petri dish assembly.

11.17 Turn multi-position switch on the control box to *Manual Up*. Push the test button on the control box down and hold it down. When the circular test head comes in contact with the specimen, synthetic blood, and petri dish assembly, the applied pressure is shown digitally on the display unit.

11.18 Look through the circular test head while pressure is being applied on the specimen, synthetic blood, and petri dish assembly. When penetration of synthetic blood is visible, stop the instrument immediately by releasing the test button on the control box and record the pressure reading on the digital display.

NOTE 6—When placed over the top of the circular test head, a lamp with a circular fluorescent bulb and center magnifying glass, will improve the observation of penetrating synthetic blood.

11.18.1 When testing protective clothing materials consisting of two or more layers, ensure that the synthetic blood has penetrated all layers. Do not stop the test prematurely.

NOTE 7—Synthetic blood penetration through outer layers appear as a shadow or pink color, whereas, penetration through all layers will appear as a red color.

11.18.2 If no penetration occurs by 90.7 kg [200 lbs], that is, equivalent to a pressure of 345 kPa [50 psi], stop the test and record *no penetration at 345 kPa [50 psi]*. **Warning**—Do not exceed the load capacity of the mechanical pressure tester as recommended by the manufacturer of the mechanical penetration tester.

11.19 Turn the multi-position switch on the control box to the *Down* position for lowering the upper platform. Remove the cover plate and circular test head from the apparatus.

11.20 If penetration occurs, check to see if synthetic blood is on the bottom of the circular test head. Clean the circular test head off with isopropanol. Discard the specimen.

11.21 Cover petri dishes containing synthetic blood when not in use to prevent evaporation of the synthetic blood. Wait at least 5 min for the foam to recover. Add 1 mL of synthetic blood to the petri dish, if needed, so that a layer of synthetic blood 1 mm [0.04 in.] covers the foam pad. Cover the petri dishes until their next use.

NOTE 8—Alternatively, the amount of synthetic blood in the foam pad can be kept constant by minimizing the weight of the foam pad and petri dish.

11.22 Test each specimen replicate with a different foam pad. Use a foam pad only ten times and then discard it. If more than ten different materials are being tested in a set, use two or more petri dishes alternatively in a replicate. Randomize the order of testing specimens within each replicate.

11.23 Turn the multi-position switch on the control box to the *Off* position when the testing sequence is over. Ensure that the upper platform is in the down position.

11.24 Calculate the average of the measured penetration pressure for all tested specimens of a particular material.

**12. Report**

12.1 State that the test was conducted as directed in Test Method F 1819.

12.2 Describe the material tested and the method of sampling used.

12.2.1 Report if the material was taken from roll goods or garments. Report the type (fiber and coating compositions), supplier, lot number, and date of receipt of the material tested. If the material was taken from garments, report under subheadings for each material, composite, type of seam, or other conditions tested, and its position on the garment.

12.3 Report the following information:

12.3.1 Thickness of each specimen and the average thickness of the specimens tested.

12.3.2 Weight of each specimen and the average weight of the specimens tested.

12.3.3 A description of any pretreatment technique used.

12.3.4 Penetration pressure level in kPa [psi] for each specimen, and the average and standard deviation of penetration pressure for all specimens tested. Determine the applied pressure in kPa [psi] by dividing the pressure recorded from the display unit by the area of the circular test head, 2570 mm<sup>2</sup> [3.98 in.<sup>2</sup>]. Table 1 provides applied pressures for selected values of display unit loads.

**13. Precision and Bias**

13.1 *Interlaboratory Test Program*—An interlaboratory study on the resistance of materials used in protective clothing to penetration by synthetic blood using a mechanical pressure technique was run in 1997. Randomly drawn samples of five materials were tested in each of six laboratories. One operator in each laboratory tested six specimens of each material. The design of the experiment followed the procedures given in Practice E 691.<sup>13</sup>

13.2 *Test Results*— The precision information given below for the average penetration pressure level (lbs and psi) is for the comparison of six test results, each of which is the average of six test determinations per material.

NOTE 9—Materials 62 and 65 were not penetrated at 200 lbf [50 psi]. All laboratories generated the same test results for the two impervious fabrics, so there was no variance and statistics could not be calculated.

13.3 *Precision*—Repeatability concerns the variability between independent test results obtained within a single laboratory in the shortest practical period of time by a single operator with a specific test apparatus and set of specimens randomly drawn from homogeneous materials. Two test results obtained within one laboratory shall be judged not equivalent if they differ by more than the *r* value for that material. Reproducibility deals with the variability between test results obtained from different laboratories. Two test results obtained by different laboratories shall be judged not equivalent if they differ by more than the *R* value for that material. See Table 2.

13.4 *Bias*—This test method has no bias because the penetration pressure level for materials is defined in terms of this test method.

**14. Keywords**

14.1 blood; blood-borne pathogens; body fluids; mechanical pressure; penetration; protective clothing; synthetic blood

<sup>12</sup> Originally developed by W.L.Gore and Assoc., Inc., Elkton, MD 21921.

<sup>13</sup> Available from ASTM Headquarters. Request RR: F23-1003.

**TABLE 1 Weight/Pressure Conversion Chart**

Applied Weight (lbs)	Pressure	
	(psig)	(kPa)
4	1	6.9
8	2	13.8
12	3	20.7
16	4	27.6
20	5	34.5
24	6	41.4
28	7	48.3
32	8	55.2
36	9	62.0
40	10	68.9
80	20	137.9
119	30	206.8
159	40	275.8
200	50	344.7



**TABLE 2 Repeatability and Reproducibility**

Material	Mean Penetration Pressure Level lbs, (psi)	Repeatability Standard Deviation ( $S_r$ ), lbs (psi)	Reproducibility Standard Deviation ( $S_R$ ), lbs, (psi)	95 % Repeatability Limit ( $r = 2.8 \times S_r$ ), lbs (psi)	95 % Reproducibility Limit ( $R = 2.8 \times S_R$ ), lbs (psi)
A (No. 44)	10.7 (2.7)	1.95 (0.49)	2.07 (0.52)	5.5 (1.4)	5.8 (1.5)
B (No. 46)	19.9 (5.0)	3.17 (0.80)	3.58 (0.90)	8.8 (2.2)	10.0 (2.5)
C (No. 51)	11.3 (2.8)	1.70 (0.43)	2.09 (0.53)	4.7 (1.2)	5.8 (1.5)

## REFERENCES

- (1) McCullough, E.A., Fosha, A. and Hosni, M., "Hydrostatic and Mechanical Pressure Applied in Barrier Test Methods," *International Nonwovens Journal*, Vol 7, No. 2, 1995, pp. 57-63.
- (2) McCullough, E.A. and Johnson, P., "Evaluation of a New Mechanical Pressure Tester for Barrier Fabrics," *Performance of Protective Clothing: 6th Volume, ASTM STP 1273*, Jeffrey O. Stull and Arthur D. Schwope, eds., ASTM, 1997.
- (3) Lentner, C., Ed., *Geigy Scientific Tables*, Volume I—Units of Measurement, Body Fluids, Composition of Blood, Hematology, Somatometric Data, Medical Education Division, Ciba-Geigy Corp., West Caldwell, NJ, 1984.
- (4) Shadduck, P. P., Tyler, D. S., Lysterly, H. K., et al, "Commercially Available Gowns Do Not Prevent Penetration by HIV-1," *Surgical Forum*, American College of Surgeons, Vol XLI, 1990, pp. 77-80.
- (5) Kotilainen, H. R., Cyr, W. H., Truscott, W., et al, "Ability of 1000 mL Water Leak Test for Medical Gloves to Detect Gloves with Potential for Virus Penetration," *Performance of Protective Clothing: Fourth Volume, ASTM STP 1133*, McBriarity, J. P. and Henry, N. W., eds., ASTM, 1992, pp. 38-48.
- (6) Brown, P. L., "Protective Clothing for Health Care Workers: Liquidproofness versus Microbiological Resistance," *Performance of Protective Clothing: Fourth Volume, ASTM STP 1133*, McBriarity, J. P. and Henry, N. W., eds., ASTM, 1992, pp. 65-82.
- (7) McCullough, E.A. and Schoenberger, L.K., "Liquid Barrier Properties of Nine Surgical Gown Fabrics," *INDA Journal of Nonwoven Research*, Vol 3, No. 3, Summer 1991, pp. 14-20.
- (8) Smith, J.W. and Nichols, R.L., "Barrier Efficiency of Surgical Gowns," *Archives of Surgery*, Vol 126, June 1991, pp. 756-762.
- (9) Altman, K.W., et al, "Transmural Surgical Gown Pressure Measurements in the Operating Theater," *American Journal of Infection Control*, Vol 19, 1991, pp. 147-155.
- (10) Telford, G.L. and Quebbeman, E.J., "Assessing the Risk of Blood Exposure in the Operating Room," *American Journal of Infection Control*, Vol 21, No. 6, December 1993, pp. 351-356.

ASTM International takes no position respecting the validity of any patent rights asserted in connection with any item mentioned in this standard. Users of this standard are expressly advised that determination of the validity of any such patent rights, and the risk of infringement of such rights, are entirely their own responsibility.

This standard is subject to revision at any time by the responsible technical committee and must be reviewed every five years and if not revised, either reapproved or withdrawn. Your comments are invited either for revision of this standard or for additional standards and should be addressed to ASTM International Headquarters. Your comments will receive careful consideration at a meeting of the responsible technical committee, which you may attend. If you feel that your comments have not received a fair hearing you should make your views known to the ASTM Committee on Standards, at the address shown below.

This standard is copyrighted by ASTM International, 100 Barr Harbor Drive, PO Box C700, West Conshohocken, PA 19428-2959, United States. Individual reprints (single or multiple copies) of this standard may be obtained by contacting ASTM at the above address or at 610-832-9585 (phone), 610-832-9555 (fax), or service@astm.org (e-mail); or through the ASTM website (www.astm.org).