



## Standard Methods for Gas Flow Resistance Testing of Filtration Media<sup>1</sup>

This standard is issued under the fixed designation F 778; the number immediately following the designation indicates the year of original adoption or, in the case of revision, the year of last revision. A number in parentheses indicates the year of last approval. A superscript epsilon ( $\epsilon$ ) indicates an editorial change since the last revision or reapproval.

### 1. Scope

1.1 The flow resistance of any fabricated filter device will depend on the flow resistance of the media used.

1.2 This standard offers procedures sufficient to determine the gas flow characteristics of flat specimens of media used in the filtration process. The methods are extended to include pleated specimens and bulk media as well.

1.3 In all cases, flow rates through the specimen are determined in accordance with procedures outlined in ASME “Fluid Meters.” The test fluid is air.

1.4 *This standard may involve hazardous materials, operations, and equipment. This standard does not purport to address all of the safety problems associated with its use. It is the responsibility of the user of this standard to establish appropriate safety and health practices and determine the applicability of regulatory limitations prior to use.*

### 2. Referenced Documents

#### 2.1 ASTM Standards:

- D 461 Test Methods for Testing Felt<sup>2</sup>
- D 585 Practice for Sampling and Accepting a Single Lot of Paper, Paperboard, Fiberboard, and Related Product<sup>3</sup>
- D 645 Test for Thickness of Paper and Paperboard<sup>4</sup>
- D 685 Method for Conditioning Paper and Paper Products for Testing<sup>3</sup>
- D 737 Test Method for Air Permeability of Textile Fabrics<sup>2</sup>
- D 1776 Practice for Conditioning Textiles For Testing<sup>2</sup>
- D 1777 Method for Measuring Thickness of Textile Materials<sup>2</sup>
- D 2905 Practice for Statements on Number of Specimens for Textiles<sup>2</sup>
- D 3574 Test Methods for Flexible Cellular Materials—Slab, Bonded, and Molded Urethane Foams<sup>5</sup>

<sup>1</sup> These methods are under the jurisdiction of ASTM Committee D22 on Sampling and Analysis of Atmospheres and are the direct responsibility of Subcommittee D22.90 on Executive.

Current edition approved January 29, 1988. Published March 1988. Originally published as F 788 – 82. Last previous edition F 788 – 82.

<sup>2</sup> *Annual Book of ASTM Standards*, Vol 07.01.

<sup>3</sup> *Annual Book of ASTM Standards*, Vol 15.09.

<sup>4</sup> Discontinued, see *1981 Annual Book of ASTM Standards*, Part 20.

<sup>5</sup> *Annual Book of ASTM Standards*, Vol 09.02.

E 105 Practice for Probability Sampling of Materials<sup>6</sup>

E 122 Practice for Calculating Sample Size to Estimate, with a Specified Tolerable Error, the Average for a Characteristic of a Lot or Process<sup>6</sup>

#### 2.2 ASME Document:

“Fluid Meters,” Sixth Edition, 1971<sup>7</sup>

### 3. Terminology

#### 3.1 Definitions of Terms Specific to This Standard:

3.1.1 *air density*,  $\rho$ —mass per unit volume.

3.1.2 *air flow resistance*,  $\Delta P$ —pressure drop or pressure differential across a test specimen of filter medium at a specified air face velocity or mass flow rate.

3.1.3 *constituted bulk media*—those types of filter media formed from bonded aggregates or discrete solid materials.

3.1.4 *edge leakage*—air flow that passes into or bypasses the test specimen in geometric planes other than those intended for resistance measurement.

3.1.5 *face area*,  $A$ —cross-sectional area perpendicular to air flow at the specimen test boundary.

NOTE 1—If specimen inlet and exit face areas are different, “Inlet” or “Exit” shall be used to describe the face area in question.

3.1.6 *face velocity*,  $V$ —volumetric flow rate per unit face area.

NOTE 2—If specimen inlet and exit face areas are different, “Inlet” or “Exit” shall be used to describe the face velocity in question.

3.1.7 *mass rate of flow*,  $\dot{m}$ —mass transport of air per unit time through the test specimen.

3.1.8 *medium area*,  $A_m$ —total area of filtration media exposed to air flow.

NOTE 3—Medium area may be greater than face area due to pleating, folding, etc.

3.1.9 *medium velocity*,  $V_m$ —volumetric flow rate per unit medium area.

3.1.10 *normalized resistance*,  $\sigma \Delta P$ —product of sigma and measured air flow resistance.

<sup>6</sup> *Annual Book of ASTM Standards*, Vol 14.02.

<sup>7</sup> Available from American Society of Mechanical Engineers, 345 E. 47th St., New York, NY 10017.

3.1.11 *sigma*,  $\sigma$ —ratio of air density existing at test conditions to standard air density. Density at standard conditions is taken to be 0.075 lb/ft<sup>3</sup> (1.201 kg/m<sup>3</sup>).

3.1.12 *unconstituted bulk media*—those types of filter media formed from unbonded aggregates or discrete solid materials.

3.1.13 *volumetric rate of flow*,  $Q$ —air volume transport per unit time through the test specimen.

#### 4. Summary of Methods

4.1 The testing outlined in this standard consists of measuring air-flow resistance (pressure drop) across a specimen of known geometry at one or more air-flow rates. Alternatively, the flow rate may be measured at one or more values of air-flow resistance across the specimen. In either case, test results are reported as single or multiple data point ordered pairs of (resistance, face velocity).

4.2 For many specimens, the air-flow resistance at flow rates of interest is of sufficient magnitude that changes in air density across the specimen may not be ignored, or the airflow resistance is not linear with face velocity. In these cases, ordered pairs of (normalized resistance, mass flow) are reported rather than ordered pairs of (resistance, face velocity).

4.3 To provide for quality control application, statistical procedures are outlined to guide in the selection of a multiple number of specimens.

4.4 Two test methods involving substantially different test techniques are presented.

4.4.1 *Method A*—A general method applicable to all filtration media and forms of media: flat, pleated, constituted, and unconstituted bulk media; small cartridge-type specimens. The test technique consists simply of mounting a specimen in a holder and applying air flow.

4.4.2 *Method B*—A limited method applying particularly to nondestructive testing of sheets of material that either edge leak or substantially deform when using the simple clamping approaches of Method A. The technique for Method B is based on the “guarded cylinder” principle and requires a concentric cylinder specimen holder, plus provision for two individually adjustable air flows (See Section 15 and Fig. 1.) In the implementation of Method B, a parallel, evenly distributed air flow is perpendicularly directed through a specimen subdivided into concentric guard and measuring area sections. The two areas have separate downstream air chambers. To obtain a (resistance, face velocity) data point, the appropriate volumetric flow rate is established through the measuring area. The guard area volumetric flow rate is then established so that the differential pressure between guard and measuring area chambers is zero on the downstream side of the specimen. Pressure drop is then read for flow through the specimen measuring area. Guard area flow rate need not be determined.

#### 5. Significance and Use

5.1 The air-flow resistance (pressure drop) of a filter is an important parameter that can assist in characterizing the physical make-up as well as the utility of a filter.

5.2 Therefore, flow characteristics of clean filter media can be used for quality control, product development, and basic research. It may be used by the producer of filter media to

illustrate media type or to meet product specification and can be used by the consumer as a criterion for media selection.

5.3 These methods may also be used for acceptance testing.

5.4 For purposes of quality control, meeting product specification, or acceptance testing, a single-point flow regime on multiple samples is adequate. However, for design, development, and research, a multiple-point flow regime may be necessary.

#### 6. General Requirements

6.1 *Instrument Accuracy*:

6.1.1 The procedures of these methods require measurement of pressure drop and either volumetric or mass flow rate.

6.1.2 Pressure drop is a direct measurement. Unless stated otherwise in the data report, instrumentation such as manometers shall be selected so as to measure pressure within  $\pm 3\%$  of the indicated value. Instruments shall be checked against a traceable standard.

6.1.3 Flow rate is generally a derived quantity obtained from computations involving a differential pressure type element and flowmeter air density. In other cases, flow rate may be obtained from some kind of direct-reading instrument such as a turbine-type flow meter. Whether read directly or computed, flow rate shall be determined to within  $\pm 3\%$ , unless stated otherwise in the data report. This value shall be checked using a flow prover with traceable accuracy.

6.2 *Test Apparatus Environment*—Effects of environmental conditions on the test air viscosity need to be examined to ensure duplication of test results.

6.2.1 *Temperature*—Air viscosity increases as temperature increases at a rate which, at 20°C, is approximately 0.15 %/°C. Seasonal changes could reflect a temperature differential of 30°C and result in the apparent flow resistance error of 4.5 %. Temperature control must be provided.

6.2.2 *Pressure*—The American Institute of Physics Handbook, 2nd Edition, gives the pressure increment of air viscosity at 20°C and 1 atm as 0.1224  $\mu\text{p}$  or a possible 0.67 % error per atmosphere. No precaution is necessary.

6.2.3 *Humidity*—The ASHRAE Handbook of Fundamentals in the chapter on Psychrometrics reveals that even for the extreme case of saturated air at 100°F there is not a significant viscosity difference from that of dry air. No precaution is necessary. However, humidity control is required in specimen preparation. See Section 10.

#### 7. Sampling

7.1 The sample to be tested as a flat media, pleated media, or bulk media should be obtained under the guidance of the particular standard or specification covering the generic material or as agreed upon between the purchaser and seller.

#### 8. Number of Specimens

8.1 Practice D 2905 covers six recommendations for determining the number of specimens necessary to elucidate the average quality of a material under various conditions. The choice of the six recommendations to be used in a specific method will depend on the purpose of the test and the available information.

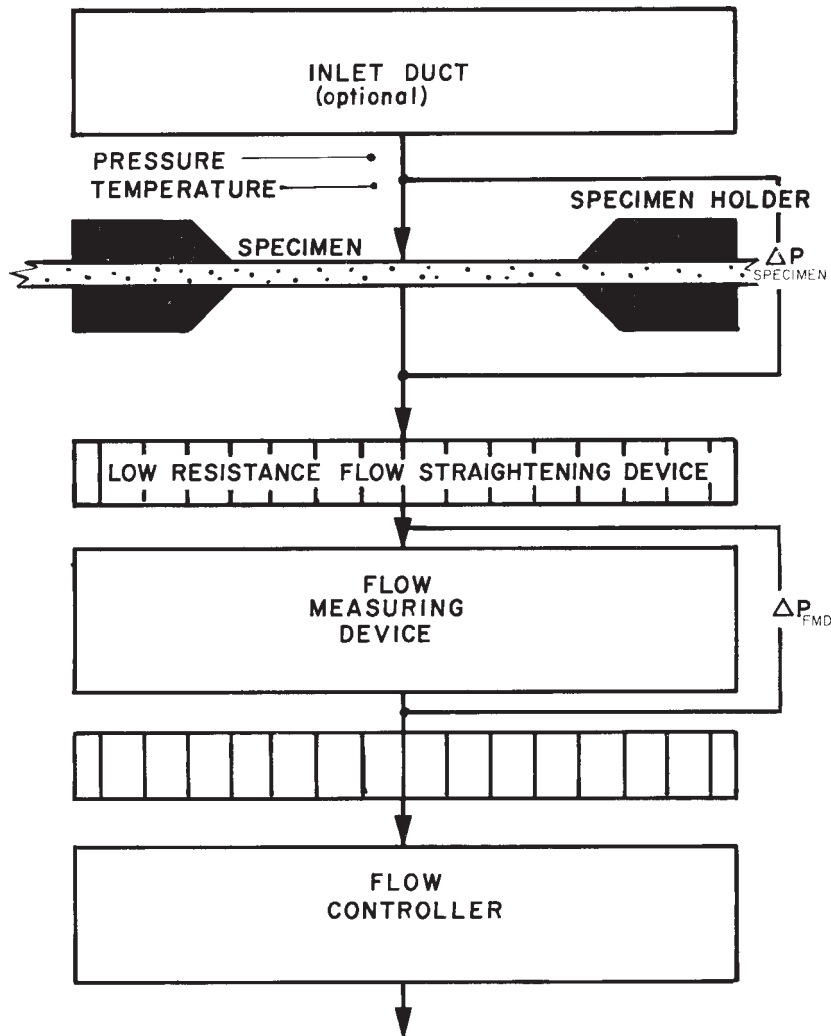

FIG. 1 System for Measuring Air-flow Resistance of Specimens with Moderate Pressure Drops

8.2 The recommendations in Practice D 2905 describe two conditions:

8.2.1 The procedure to follow when the user has a reliable estimate of the variability of the method in his own laboratory; and,

8.2.2 When the user does not have a reliable estimate of the variability of the method in his own laboratory.

8.3 If the laboratory has a reliable estimate of variation expressed either as a standard deviation or as a coefficient of variation, then the number of specimens could be determined by the following equations:

$$n = (t^2 \times s^2)/E^2$$

$$n = (t^2 \times v^2)/A^2$$

where:

$n$  = number of test specimens required, rounded to the next higher whole number,

$s$  = standard deviation of individual observations expressed in the appropriate units,

$v$  = coefficient of variation of individual observations expressed as percent of the average,

$v = 100 s / \bar{x}$ , and

$\bar{x}$  = average of all the observations for a specific material  
 $t$  = a constant depending upon the desired probability level and equal to Student's  $t$  for infinite degrees of freedom, for example:

Probability Level, %	One-sided Limits		Two-Sided Limits	
	$t$	$t^2$	$t$	$t^2$
90	1.282	1.644	1.645	2.706
95	1.645	2.706	1.960	3.842
99	2.326	5.410	2.576	6.636

$E$  = the allowable variation of the test results expressed in the same units as  $s$ , and

$A$  = the allowable variation of the test results expressed as a percent of the average.

8.4 Criterion for the selection of the appropriate procedure hinges on: (1) choosing between  $s$  or  $v$  as the measure of variability; (2) choosing a one-sided or two-sided limit for the property being measured; and, (3) if no variation data are

available, arbitrarily decide on the number of specimens dictated by the type and character of the material. For more details, refer to Section 5 of Practice D 2905.

## 9. Conditioning of Test Specimens

9.1 Because many of the materials used in filter media undergo physical changes with changes in temperature and moisture, it is usually desirable to expose the test specimen to a standard conditioned atmosphere for a period of time before testing is initiated.

9.2 Those materials which are considered to be textiles or textile-like (woven, knitted, or nonwoven fabrics; fiber batts or mats; or coated fabrics) should be conditioned as specified by Practice D 1776. The standard atmosphere for this Practice is a relative humidity of  $65 \pm 2\%$  and a temperature of  $21 \pm 1^\circ\text{C}$  ( $70 \pm 2^\circ\text{F}$ ). When international testing is involved, a relative humidity of  $65 \pm 2\%$  and a temperature of  $20 \pm 2^\circ\text{C}$  may be used.

9.3 Those materials which are considered to be paper or paper-like should be conditioned as specified by Method D 685. The standard atmosphere for this Practice is a relative humidity of  $50 \pm 2\%$  and a temperature of  $23 \pm 1^\circ\text{C}$  ( $73.4 \pm 1.8^\circ\text{F}$ ).

9.4 The time duration required for conditioning should be that necessary for the test specimen to attain equilibrium with the conditioning atmosphere. This is considered to have occurred when the change in the mass of the specimen in successive weighings made at intervals of not less than 2 h, does not exceed 0.2 % of the mass of the specimen.

9.5 At times, it may be judged inappropriate to condition the specimen prior to testing. When conditioning is not used it should be so reported in the results. See Section 18.

## 10. Dimensional Measurement of Test Specimens

10.1 Determine media thickness *prior* to mounting for test and in accordance with standards such as Methods D 461 (Section 10), D 645, D 1777, and D 3574 (Section 7).

10.2 Cut media specimens to be used in other than simple mounting techniques and install in holders without altering the physical character of the matrix (for example, fused edges, torn edges, etc.).

10.3 Determine specimen face area (and medium area if different) subsequent to specimen mounting according to Section 6.

NOTE 4—For flat media to be tested using the simple clamping procedures of Method A, or to be tested using Method B, the test specimen holder will dictate specimen face area.

NOTE 5—Dimensions of specimen holders and packing procedures for bulk media are required prior to test. Note any settling of these media as a result of air-flow testing (see Section 18).

## METHOD A

### 11. Requirements for Method A

#### 11.1 Specimen Mounting:

11.1.1 *General*—Specimen mounting is a critical consideration in the application of this test method. It is a requirement that mounting techniques be selected which eliminate edge leakage, yet do not deform the medium to the extent that air-flow resistance is affected.

11.1.2 *Flat Media*—For flat filtration media in particular, it is desirable to use simple clamping techniques such as suggested in Annex A1 instead of more elaborate specimen preparation. Absence of edge leakage or clamping deformation effects for simple clamping or both, shall be demonstrated for each *new* combination of material and clamping method used. To do this, the new combination of material and simple clamping method shall be tested; then the same specimen shall be retested with edge sealing and spacer bar of equivalent thickness to the test specimen. No change in resistance shall be noted.

11.1.3 *Pleated Specimens*—Positive end sealing of pleats is required. Three suggested mounting schemes are delineated in Annex A2.

11.1.4 *Bulk Media*—Air-flow resistance of bulk media is materially affected by the packing method used. It is a requirement that the packing procedure be fully documented in any test of these materials (see Section 18).

11.2 *Specimen Area*—Specimen size shall be dictated by the prevailing practice for the class of materials under test. Examples are 5.94 in.<sup>2</sup> (38.32 cm<sup>2</sup>) for papers and paperlike materials and 15.5 in.<sup>2</sup> (100 cm<sup>2</sup>) for blanket-like materials. In no case shall test specimen size for flat media be less than 5.94 in.<sup>2</sup> (38.32 cm<sup>2</sup>). Specimens may be rectangular or round; however, rectangular specimens with length to width ratios different by more than 2:1 are to be avoided.

#### 11.3 Measurement of Pressure and Pressure Drop:

11.3.1 Pressure tap location can materially affect test values for some kinds of specimens. Pressure taps are required to be flush with duct walls at a distance up and downstream sufficient to ensure localized flow irregularities caused by specimens and specimen holders that have disappeared. Multiple taps in a single flow plane, located 90° apart and manifolded together, are to be preferred over a single tap.

11.3.2 If a media support grid or bulk media holder is used, a test shall be performed with no media present to demonstrate that the effects of such media supporting devices can be ignored. This same test shall be performed if an upstream, or downstream, duct with pressure taps is *not* employed.

11.4 *Test Air Density*—This method requires that the test air density be known at the specimen and at the flow measuring device locations. Determinations of air density from experimentally measured absolute temperature and pressure can be kept at a minimum if the air density of the test apparatus environment equals that at the specimen inlet

$$\rho_{\text{env.}} = \rho_{\text{sp. inlet}}$$

and the air density at the flow measuring device (FMD) equals that at the specimen outlet

$$\rho_{\text{FMD}} = \rho_{\text{sp. outlet}}$$

The condition

$$\rho_{\text{env.}} = \rho_{\text{sp. inlet}}$$

will generally prevail. When no inlet duct is present (See 17.5.3) the air density at the specimen inlet may be calculated



from local barometric pressure and ambient environmental temperature in the test area. The condition of

$$\rho_{\text{FMD}} = \rho_{\text{sp. outlet}}$$

is expected to prevail and the air density at the flow measuring device is calculated from the absolute temperature and pressure determined experimentally. This latter air-flow density ( $\rho_{\text{FMD}}$ ) is used in calculating mass flow rate. The effect of relative humidity on air density is considered negligible for the ranges of temperature and humidity used in this standard. See Section 9, 13.2, and 16.2.

## 12. Test Apparatus

12.1 Fig. 1 is a schematic diagram of the basic system for measuring air-flow resistance of specimens with moderate pressure drops, 10 in. Hg (254 mm Hg) or less, at the air flows of interest. For specimens with higher pressure drops, a blow-through system is recommended rather than the suction system for Fig. 1. In selecting the correct design, many materials are evaluated by determining the cubic feet per minute of air flow per square foot specimen face area ( $\text{cm}^3/(\text{s}\cdot\text{cm}^2)$ ) at a differential pressure ( $\Delta P_{\text{specimen}}$ ) of 0.5 in. (12.7 mm) of water (Method D 737), or when the face velocity is 35 ft/min (17.8 cm/s) the pressure drop is determined.

12.2 The flow-measuring device should be selected in accordance with the standards and practices of ASME, "Fluid Meters." Most common test apparatus designs employ differential pressure meters (such as nozzles or orifices) for which the volume rate of flow  $Q$  is given by a relationship of the type

$$Q \propto d^2 \sqrt{\Delta P_{\text{FMD}} / \rho_{\text{FMD}}}$$

where:

- $\Delta P_{\text{FMD}}$  = nozzle or orifice pressure drop,
- $\rho_{\text{FMD}}$  = density of the test air, and
- $d$  = orifice diameter.

A similar relationship for the flow rate through a rotameter with its float at a specific position is:

$$Q \propto 1/\sqrt{\rho_{\text{FMD}}}$$

Therefore, flows measured by orifices, nozzles, or variable area types (rotameters) must be corrected when testing under conditions other than those at which these flow measuring devices were calibrated.

12.3 There is technology available for a linear flow-measuring device for use when the test specimen flow characteristics follow:

$$\frac{\Delta P}{t} = K\mu V$$

where:

- $V$  = volumetric rate of flow per unit face area (face velocity),
- $\mu$  = gas viscosity,
- $t$  = specimen thickness, and
- $K$  = a constant for a given material.

Other air-flow equations that relate the pressure drop to the first power of the face velocity are the Poiseuille, Chen, and the Blake-Cozeny equations. Under these circumstances Marion A. Hollingsworth<sup>8</sup> has shown that a media resistance test stand incorporating a Laminar Flow Element (Meriam Instrument) is entirely self-compensating, and no differences from standard conditions in either air-flow density or viscosity need be examined for possible corrections, provided there is no significant pressure loss between sample and laminar flow element.

## 13. Procedure

### 13.1 Functional Check of Instrument:

13.1.1 Insert a test plate or some other accepted standard in the test specimen location, and measure its rated air-flow resistance using the test apparatus and instrument procedure established. The functional test point must be within 25 % (plus or minus) of midscale.

13.1.2 For consistent results, it is necessary that the fluid meniscus always be observed in the same way. In vertical tube instruments, the fluid level in the center of the tube should be noted in each case, whether the top surface is concave or convex in form. To duplicate factory calibration procedure with the inclined tube meter, with mercury, read to the highest indicated liquid level as measured by a line parallel to the graduations of the scale. With any other liquid, the lowest visible level should be used, as measured by the same procedure. It is important to remember that the levels in both legs of U-tube manometers must be read and these readings added together to obtain the actual indication. A plane tangent to the fluid meniscus and at right angle to the tube bore intercepts the scale where it should be read. See Fig. 2.

13.2 Test the appropriately conditioned specimen in the environment to which the specimen was exposed.

13.3 Select the specimen, and place it into the clamping device making sure the specimen surface is facing the flow in its normal in-service orientation. A specimen's air flow resistance may differ according to which surface faces the flow. Such terms as "felt side" and "wire or chain side" have often been used to describe observable differences between sides. Pronounced directional differences in air-flow resistance are most frequently encountered with those media consisting of layers of different density or media which undergo changes in resistance with flow rate. If in doubt, measure flow resistance with each side of the specimen facing the air flow. See 17.3.

13.4 Clamp or hold in place with sufficient force to ensure no edge leakage. For flat specimens with simple clamping, this should be determined by increasing the sample holding force until the differential pressure across the specimen reaches equilibrium at the prescribed air flow. Once this is determined, hold constant for subsequent testing.

13.4.1 Where planar orientation is important, the orientation must be appropriately documented.

<sup>8</sup> Hollingsworth, Marion A., "A New Filter Media Flow Resistance Tester," *ASHRAE Transactions*, Am. Soc. Heating, Refrigerating, and Air Conditioning Engineers Vol 84, 1978, Part 1.

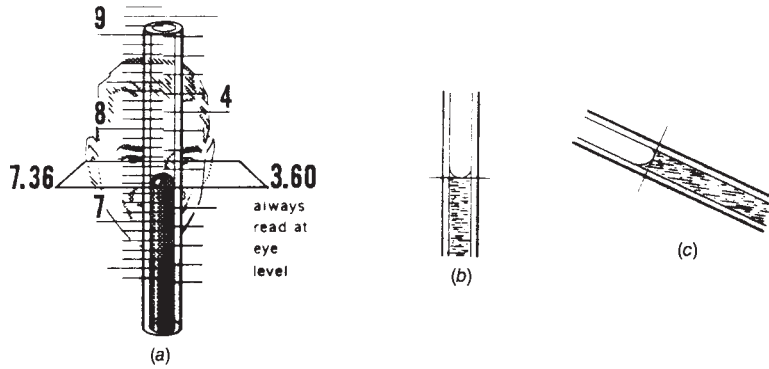

FIG. 2 Observation of Fluid Meniscus

13.4.2 Samples that are obviously distorted by clamping (for example, thin but deeply corrugated mediums, semi-rigid foams, etc.) may be more readily tested by Method B.

13.5 Using good instrument practices (reading the vertical manometer at mid-scale), determine the flow rate at the flow-measuring device at a specified medium  $\Delta P$  or determine the specimen flows for several  $\Delta P$ 's, or both. (See 17.1-17.4.)

13.6 If the test air density at specimen and flowmeasuring device locations is constant and equal, then only one reading for temperature, pressure, and humidity is required.

## METHOD B

### 14. Requirements for Method B

#### 14.1 Specimen Mounting:

14.1.1 Because of the "guarded cylinder" principle, specimen mounting in the sense of the simple clamping of Method A is usually not applicable. Certain kinds of materials may, however, exhibit a tendency to deviate from a perfectly flat condition when placed on the guard cylinder surface. Since accuracy of the procedure depends on *no* cross flow between guard and measuring areas, for these materials it may be necessary to provide an auxiliary clamping device to ensure flatness against the guard cylinder surface.

14.1.2 For flexible materials, the simple clamping procedures of Method A applied outside of the guard area will be satisfactory. For other materials which are locally rigid (for example, wire screens), an inlet duct whose inner and outer diameters match the lower chamber diameters may be used as a clamp.

14.2 *Specimen Area*—A circular test area shall be used. The minimum face area of the center test section shall be 38.75 in.<sup>2</sup> (250 cm<sup>2</sup>). It is suggested that the ratio between guard area and measuring area be 3:1; however, in no case shall the ratio of guard to measuring area be less than unity.

14.3 *Measurement of Pressure and Pressure Drop*—The same requirements as described for Method A also apply to Method B (See 11.3).

14.4 *Test Air Density*—The same requirements as for Method A also apply to Method B (See 11.4).

### 15. Test Apparatus

15.1 Fig. 3 is a schematic diagram of a system for testing with the "guarded cylinder" principle. As with Method A, the system as configured is recommended for specimens with

moderate pressure drops (10 in. Hg (254 mm Hg) or less). For specimens with higher pressure drops, a blow-through system is recommended rather than the suction system of Fig. 3.

15.2 As in Method A, the flow-measuring device should be selected in accordance with practices outlines in ASME "Fluid Meters."

15.3 If the laminar flow-element measuring device is selected, it is recommended that a filter (see Fig. 3) be inserted just upstream from the flow-measuring device.

15.4 For simple suction systems, a manual damper should be provided to release the suction pressure on the specimen. This will allow for easier repositioning of the media under test.

### 16. Procedure

#### 16.1 Functional Check of Instrument:

16.1.1 Insert a test plate or some other accepted standard in the apparatus. The test plate must cover both guard and measuring areas. Measure air-flow resistance using the test apparatus and instrument procedure established. The functional test point must be within 25 % (plus or minus of midscale). Observe manometer reading practices outlined in 13.1.2.

16.2 Test the appropriately conditioned specimen in the environment to which the specimen was exposed.

16.3 Select the specimen and place over guard and measuring areas, making sure the specimen surface is facing the flow in its normal in-service orientation (see Note 4/Note 4). Take care to ensure that the specimen is flat across the guard boundary (see 14.1).

16.4 Using good instrument practices, establish the desired flow rate at a specified specimen  $\Delta P$  for the (measuring) test section. Next, establish guard area flow until pressure difference between guard and measuring chambers downstream of the specimen is zero. Reread specimen  $\Delta P$  and flow for the measuring test section.

16.4.1 If specific flow points are desired, some trial and error may be required before the downstream guard and measuring chambers are pressure balanced at the exact test flow.

16.4.2 If multiple data point ordered pairs are required, repeat the above procedure.

16.5 If the test air density at specimen and flow-measuring device locations is constant and equal, then only one reading of pressure, temperature, and humidity is required.

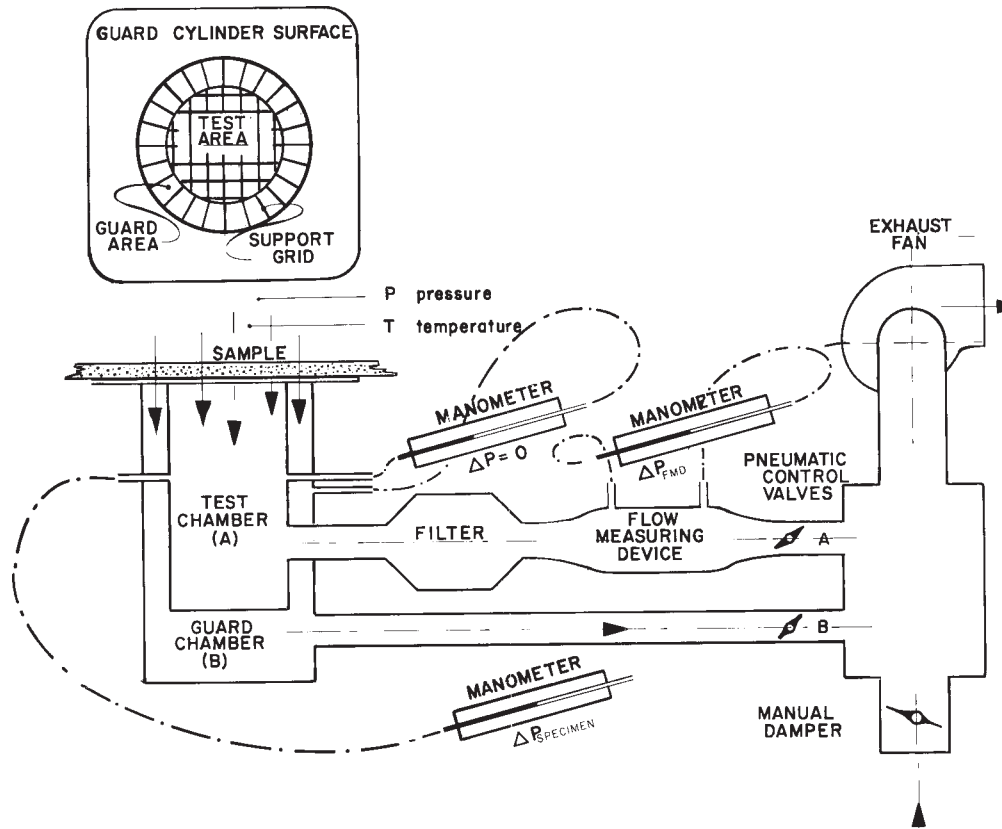

FIG. 3 Method B—Guarded Cylinder Principle

## CALCULATION AND REPORT

### 17. Calculation

17.1 The purpose of this standard is to determine experimental values for resistance, face velocity or normalized resistance, mass flow ordered pairs so that the user may apply the functional equation of his choice.

17.2 Limitation of test temperature conditions have eliminated the need for viscosity corrections to the test data.

17.3 Whether data point pairs of resistance, face velocity ( $\Delta P, V$ ) or normalized resistance, mass flow ( $\sigma \Delta P, \dot{m}$ ) are reported, however, depends on a knowledge of the influence of Reynolds Number on specimen air-flow resistance and whether or not the pressure drop is of sufficient magnitude that the effects of variable test air density through the specimen must be considered.

17.3.1 When the influence of Reynolds Number is small, the specimen resistance is linear with face velocity, and it is not necessary to apply any calculations to the observed pressure drop. When the influence of Reynolds Number is not small, there are both viscous and inertial contributions to the pressure drop of the specimen, and resistance is no longer linear with face velocity. When this occurs, it is necessary to report observed pressure drop of the specimen normalized to a standard density condition at the test value(s) of air-mass flow rate.

17.3.2 Some cases of nonlinearity in the specimen resistance are attributable not to an inertial component in the

pressure drop, but to physical changes in the specimen. If it is determined that physical changes occurring during flowing conditions are the sole cause of specimen resistance, nonlinearity with face velocity, then no calculations need be applied to the observed pressure drop of the specimen.

17.3.3 When pressure drop through the specimen is large, the air density at inlet and exit faces of the specimen can be considerably different, and it is necessary to account for this difference.

17.3.4 One method is to calculate an average volumetric flow rate through the specimen by means of the average air density at specimen inlet and exit faces. Another method, and that which will be used here, is to report pressure drop normalized to a standard density condition at the test value of air mass flow rate.

17.3.5 It should be noted that normalized resistance, mass flow pairs ( $\sigma \Delta P, \dot{m}$ ) are reported when density corrections must be made irrespective of whether or not the specimen resistance is linear with face velocity.

17.4 The calculations necessary to prepare the data for reporting are outlined in the following paragraphs.

17.5 *Case 1*—Specimen resistance is assumed to be linear, or (1) sufficiently close to linear with face velocity, that Darcy's law may be said to apply; or, (2) if the specimen resistance is nonlinear, the nonlinearity is attributable to media compression under flowing conditions.

17.5.1 In this case, no calculations are applied to pressure drop data. Volumetric flow through the specimen is calculated

from flow-measuring device data; then face velocity calculated by dividing the volumetric flow by the specimen face area. The specimen data to be reported are either single or multiple data point ordered pairs of ( $\Delta P$ ,  $V$ ).

17.5.2 If inlet and exit face areas are not equal, either inlet or exit face velocity may be used in reporting, but “Inlet” or “Exit” shall be used to describe the face velocity in question (see 3.1.5 and 3.1.6).

17.5.3 It is imperative that the flow-measuring device data be employed in such fashion that actual volumetric flow be determined, *not* corrected to standard conditions. It is also necessary to ensure that the air density at specimen exit and at flow-measuring device inlet are within ½ %. For most tests at normal laboratory conditions, a pressure drop of 2 in. water (51 mm water) or less between these two stations will ensure that this condition is met.

17.5.4 Some specimen configurations may exhibit pressure drops in a range of interest where density differences of the test air across the specimen must be considered. In these methods, when

$$\Delta P/P_{\text{inlet absolute}} \geq 0.05$$

air density differences must be considered and data is to be reported as ( $\sigma \Delta P$ ,  $\dot{m}$ ) pairs. (See Case II).

17.5.5 The ratio  $\Delta P/P$  is dimensionless, so the pressure drop of the specimen and the absolute pressure of the air at the specimen inlet must be expressed in the same units. For suction systems, the absolute pressure will be the local barometer in the test area, less any inlet duct losses. It is typically on the order of 407 in. H<sub>2</sub>O (10 300 mm H<sub>2</sub>O) for the standard atmosphere. (More conventional units are 29.92 in. Hg absolute or 760 mm Hg.; however, pressure drop across the specimen must then be converted to inches (or millimetres) of Hg to calculate  $\Delta P/P$ .)

17.6 *Case II*—Specimen resistance is nonlinear with face velocity, (1) attributable solely to an inertial component in the pressure drop; or, (2) air density differences across the specimen must be considered.

17.6.1 In this case, the observed pressure drop of the specimen ( $\Delta P$ ) must be normalized to standard conditions by multiplying each value of  $\Delta P$  by the density ratio  $\sigma$  (see Section 5). The data to be reported are either single or multiple data point ordered pairs of normalized pressure drop, mass flow rate ( $\sigma \Delta P$ ,  $\dot{m}$ ).

17.6.2 Determine data point pairs as follows:

17.6.2.1 Calculate mass flow rate ( $\dot{m}$ ) through the specimen from flow-measuring device data.

17.6.2.2 Calculate density ratio ( $\sigma$ ) at the specimen location using average values of absolute temperature and pressure as follows:

$$\begin{aligned} \bar{P}_{\text{absolute at specimen}} &= P_{\text{inlet absolute}} - \Delta P/2 \\ & \text{(in. Hg abs)} \quad \text{(in. Hg abs)} \quad \text{(in. Hg abs)} \\ \bar{T}_{\text{absolute}} &= [(T_{\text{inlet}}(^{\circ}R) + T_{\text{exit}}(^{\circ}R))/2] \\ \sigma &= (\bar{\rho}/\rho_{\text{STD}}) \\ &= (\bar{\rho}/0.075 \text{ lb/ft}^3) \end{aligned}$$

$$\begin{aligned} &= (527.7^{\circ}R/\bar{T}_{\text{specimen}}(^{\circ}R)) \\ &\times (P_{\text{absolute}}/29.92 \text{ in. Hg abs}) \end{aligned}$$

$$\text{or } \sigma = (\bar{\rho}/1.201 \text{ kg/m}^3)$$

$$= [293.2 \text{ K}/\bar{T}(\text{K})] \times [\bar{P}_{\text{absolute}}(\text{mm Hg})/760 \text{ mm Hg}]$$

17.6.2.3 Calculate  $\sigma \Delta P$  by multiplying the observed pressure drop by its appropriate  $\sigma$ .

17.6.3 Historically, mass flow rates have often been reported as standard volumes per unit time. For purposes herein, standard volumes per unit time may be regarded as mass flow rates, provided they are determined from mass flow data by:

$$Q_{\text{STD}} = \dot{m}/\rho_{\text{STD}} \quad (1)$$

The use of standard volumes per unit time instead of mass rates of flow is discouraged.

17.7 *Case III*—Behavior of specimen resistance with face velocity is unknown for region of test.

17.7.1 In this case, a multiple data point procedure is required covering flows such that six data points of 25 %, 50 %, 75 %, 100 %, 150 %, and 200 % of the rated condition are obtained. Observation under flowing conditions is required to ensure that the test medium is not deflecting from air-flow forces.

17.7.2 Data point pairs to be determined are ( $\sigma \Delta P/\dot{m}$ ,  $\dot{m}$ ) for each of the test points. These are determined as follows:

17.7.2.1 Calculate mass flow rate ( $\dot{m}$ ) from flow measuring device data.

17.7.2.2 Calculate  $\sigma$  (See 17.6.2.2). Pressure drop of the specimen may be omitted if

$$\frac{\Delta P}{P_{\text{inlet absolute}}} \leq 0.05$$

17.7.2.3 Calculate  $\sigma \Delta P$ .

17.7.2.4 Plot  $\sigma \Delta P/\dot{m}$  versus  $\dot{m}$  on linear scale graph paper.

17.7.3 If  $\sigma \Delta P/\dot{m}$  is constant, or nearly constant, then the influence of Reynolds Number (which is proportional to  $\dot{m}$ ) is minimal, and the influence of any observed media deformation is also negligible. The specimens may thus be treated in accordance with Case I (see 17.5). If  $\sigma \Delta P/\dot{m}$  is not constant, there is either an influence of Reynolds Number or a changing flow resistance caused by specimen deformation. If the influence of specimen deformation is not significant and the inertial component to the pressure drop is fully established, the plot of  $\sigma \Delta P/\dot{m}$  versus  $\dot{m}$  will appear as a straight line with positive slope. The specimens may be treated in accordance with Case II. If the graph of  $\sigma \Delta P/\dot{m}$  versus  $\dot{m}$  is neither constant nor linear with positive slope, the specimen is deforming with air flow, or there is an extended flow transition regime. In either eventuality, data are to be reported as for Case II and a note added that extrapolations outside the test regime are to be avoided. See Fig. 4.

## 18. Report

18.1 The report shall include the following:

18.1.1 The ASTM number and whichever Method, A or B, is used.

18.1.2 Test environmental conditions such as relative humidity, temperature, and pressure.



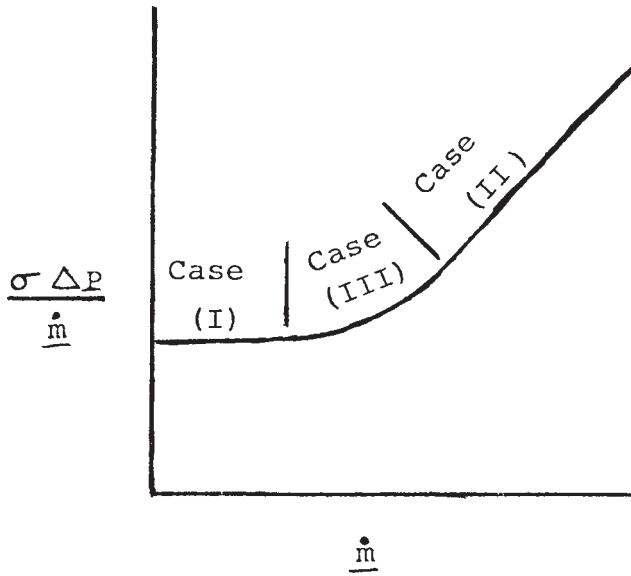

FIG. 4 Graph of  $\sigma \Delta P / \dot{m}$  versus  $\dot{m}$

18.1.3 A schematic of the test specimen assembly, which includes a thorough description of any critical orientations. In the case of bulk media specimens, a detailed packing procedure must be outlined. All specimen dimensions must be documented. For those test specimens where inlet and outlet areas at pressure tap locations are different, flow cross-sectional areas at pressure measuring stations must be included.

18.2 For Case I (refer to 17.5), the report shall include:

18.2.1 Single-point ( $\Delta P, V$ ) pair or

18.2.2 Multiple-point ( $\Delta P, V$ ) pairs.

18.2.2.1  $\Delta P$  should have units of force per unit area. (Height of a liquid column may also be employed.)

$$(mL/t^2) \quad (1/L^2)$$

18.2.2.2  $V$  should have units of volume flux per unit area.

$$L/t \quad (2)$$

18.3 For Case II (refer to Section 17.6), the report shall include:

18.3.1 Single-point ( $\sigma \Delta P, \dot{m}$ ) pair or

18.3.2 Multiple-point ( $\sigma \Delta P, \dot{m}$ ) pairs

18.3.2.1 The same dimensional units for  $\Delta P$  will be used as outlined in 18.2.

18.3.2.2  $\dot{m}$  should have units of  $m/t$

18.4 For Case III (refer to 17.7), the report shall include:

18.4.1 A graph of  $\sigma \Delta P / \dot{m}$  versus  $\dot{m}$  on linear scale graph paper

18.4.1.1  $\sigma \Delta P$  and  $\dot{m}$  units are the same as outlined in 18.3.

18.4.2 The determination of specimen behavior according to the guidelines of 17.7.2 and 17.7.3 plus

18.4.2.1 A report in accordance with Case I if  $\sigma \Delta P / \dot{m}$  is constant or nearly constant versus  $\dot{m}$

18.4.2.2 A report in accordance with Case II if  $\sigma \Delta P / \dot{m}$  is a straight line with positive slope versus  $\dot{m}$

18.4.2.3 A report in accordance with Case II if  $\sigma \Delta P / \dot{m}$  is neither constant nor linear with positive slope versus  $\dot{m}$ , plus a note that extrapolations outside the test regime are to be avoided.

19. Precision and Bias

19.1 Precision:

19.1.1 Single laboratory-single operator precision. Two regimes of face velocity are presented:

19.1.1.1 Face Velocity of 5 cm/s—The average single laboratory-single operator experimental percent variation of this test at a challenge of 5 cm/s face velocity on 25 samples of low variability is 2.03 % at the 95 % confidence level, as shown in STP 975.<sup>9</sup>

19.1.1.2 Face Velocity of 25 cm/s—The average single laboratory-single operator experimental percent variation of this test at a challenge of 25 cm/s face velocity on 50 samples of low variability is 3.46 % at the 95 % confidence level.

	Mean (in. H <sub>2</sub> O)	Standard Development	% Variation 95 % Confidence Level
Lab 1	0.9549	2.62	5.26
Lab 2	0.9550	1.39	2.79
Lab 3	0.9496	1.14	2.29
			average 3.46

19.1.2 Multi-Laboratory-Single Operator Precision—One regime of face velocity is presented. Testing was done in the form of a 3-level completely nested designed experiment. The output of such a design allows the separation of the different components of variance: laboratory, sample and run duplication.

19.1.2.1 Face Velocity of 25 cm/s—The multi-laboratory-single operator percent variation of this test between three laboratories was 8.38 % at the 95 % confidence level. The majority of the variability is attributed to reproducibility between runs.

Source	Components of Variance		Estimated Standard Deviation Based on N
	Com-ponent of Variance	%of Total Variance	
Laboratory	0.000016	4.91	0.003959
Sample	0.000118	37.11	0.010885
Run	0.000185	57.99	0.013608
Total	0.000319		0.017870

19.2 Bias—No justifiable statement can be made on the accuracy of measuring air-flow resistance, since the true value of the property cannot be established for most filter materials or specimens.

<sup>9</sup> ASTM STP 975, Fluid Filtration Gas, available from ASTM Headquarters.

A1. SIMPLE SPECIMEN CLAMPING SUGGESTIONS FOR VARIOUS TYPES OF FLAT MEDIA—METHOD A

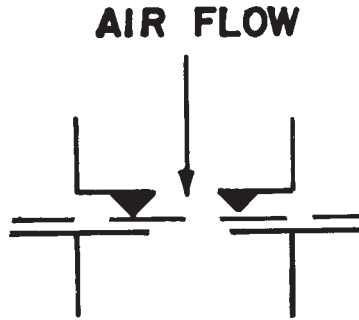

FIG. A1.1 Sharp Edge—Top Clamp

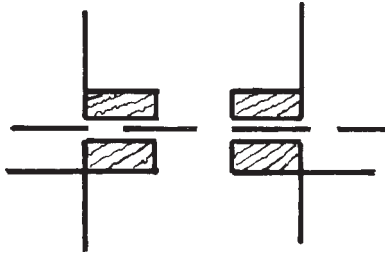

FIG. A1.2 Soft Gaskets—top and bottom clamp or chamber

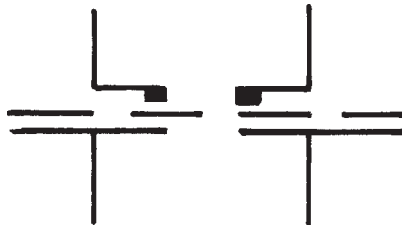

FIG. A1.3 Pneumatic actuated top clamp with low surface area sealing

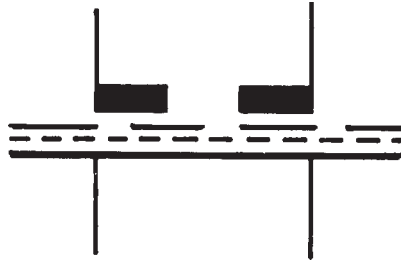

FIG. A1.4 Support grid of known air flow resistance and construction

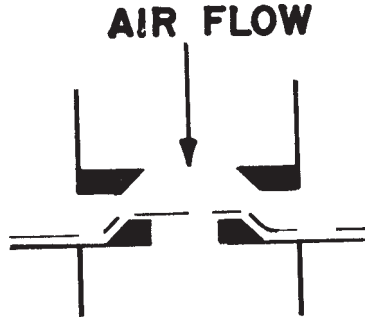

FIG. A1.5 Weight ring to produce known tension

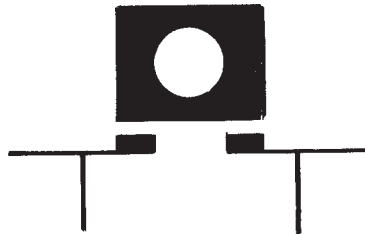

FIG. A1.6 Thick Rigid Specimen—Impregnate with barrier-type material except for test area



FIG. A1.7 Special holder to fit exact thickness of specimen

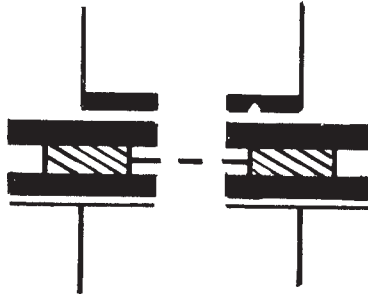
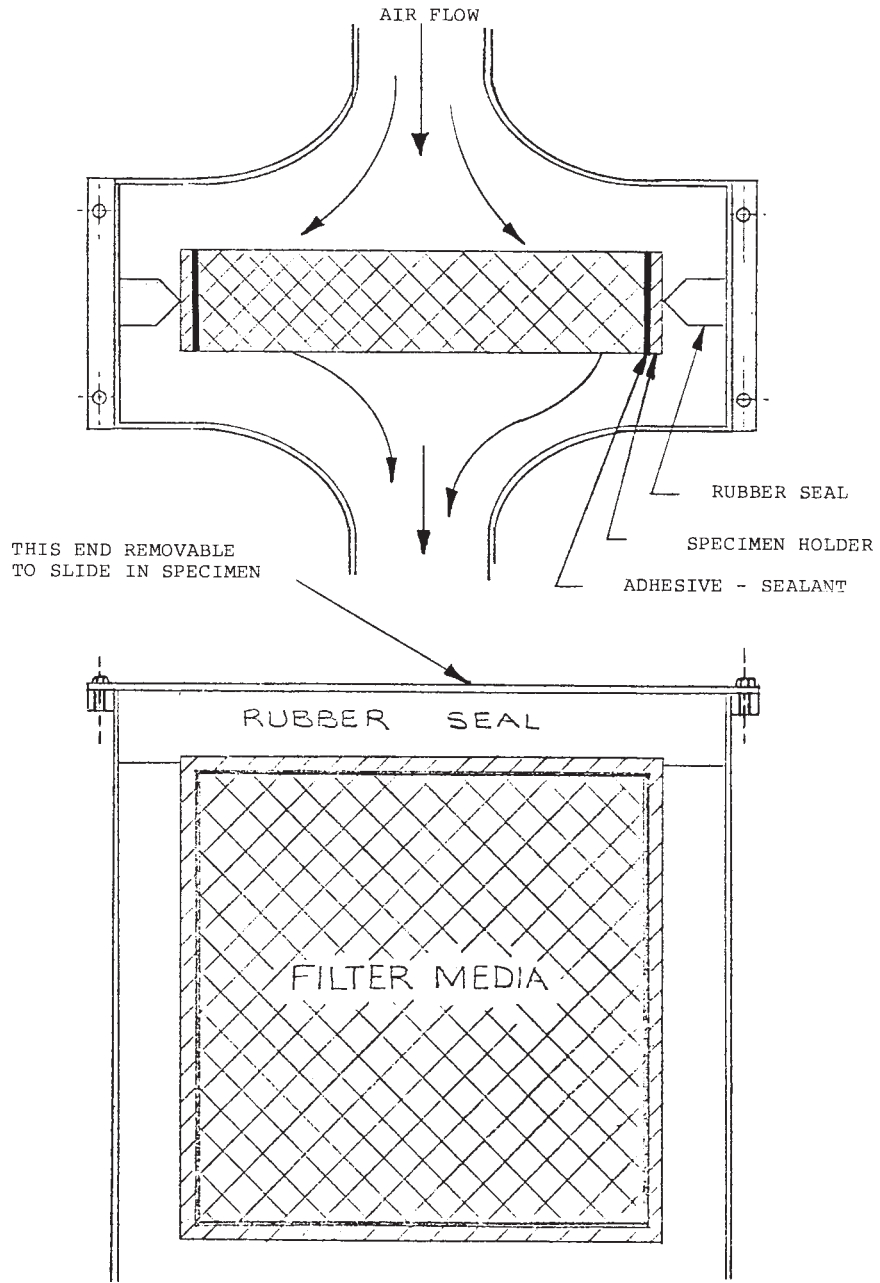
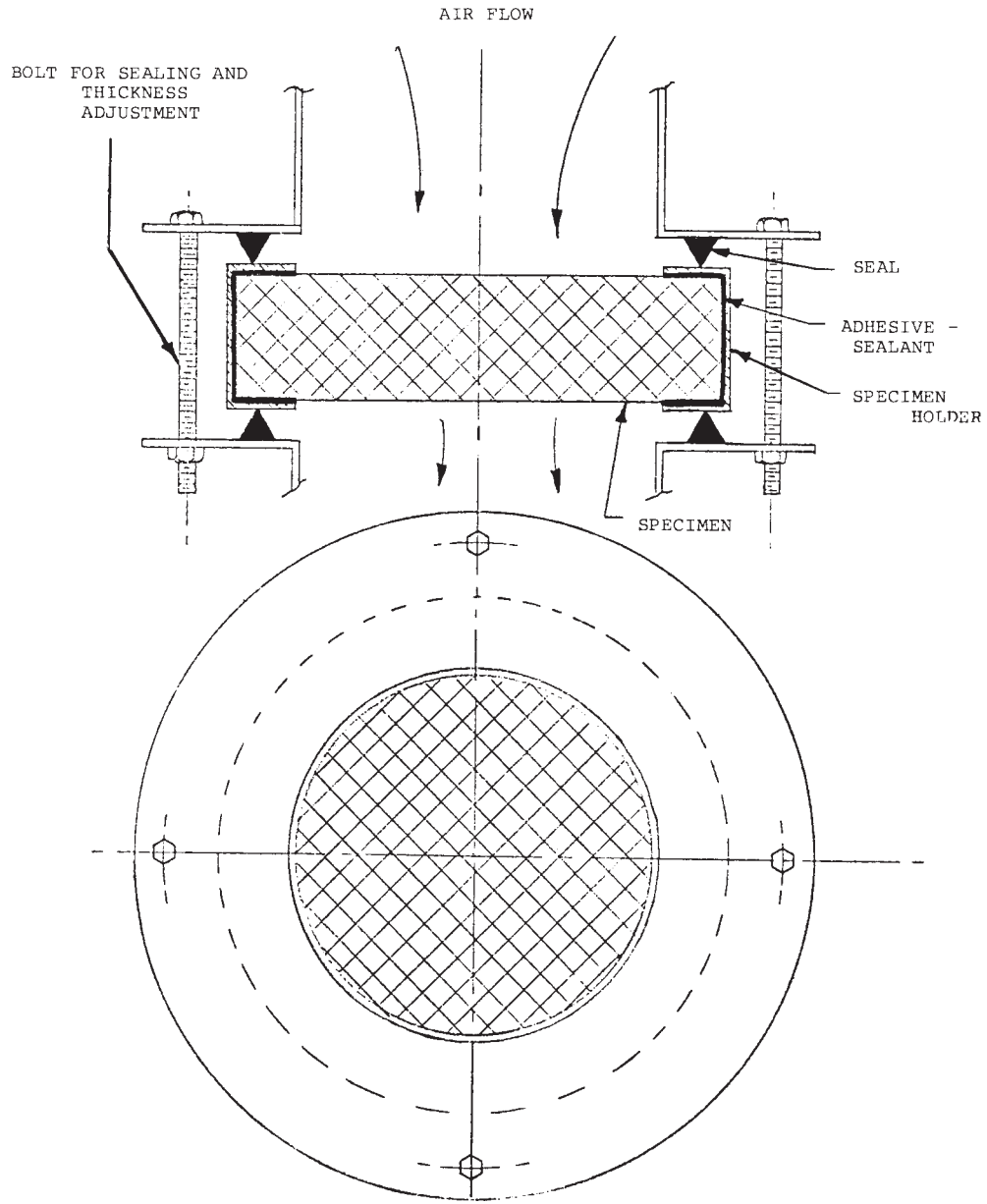



FIG. A1.8 Special holder with crushable gasket to conform to specimen surface irregularities

## A2. PLEATED SPECIMEN MOUNTING—METHOD A







 **F 778 – 88 (2001)**

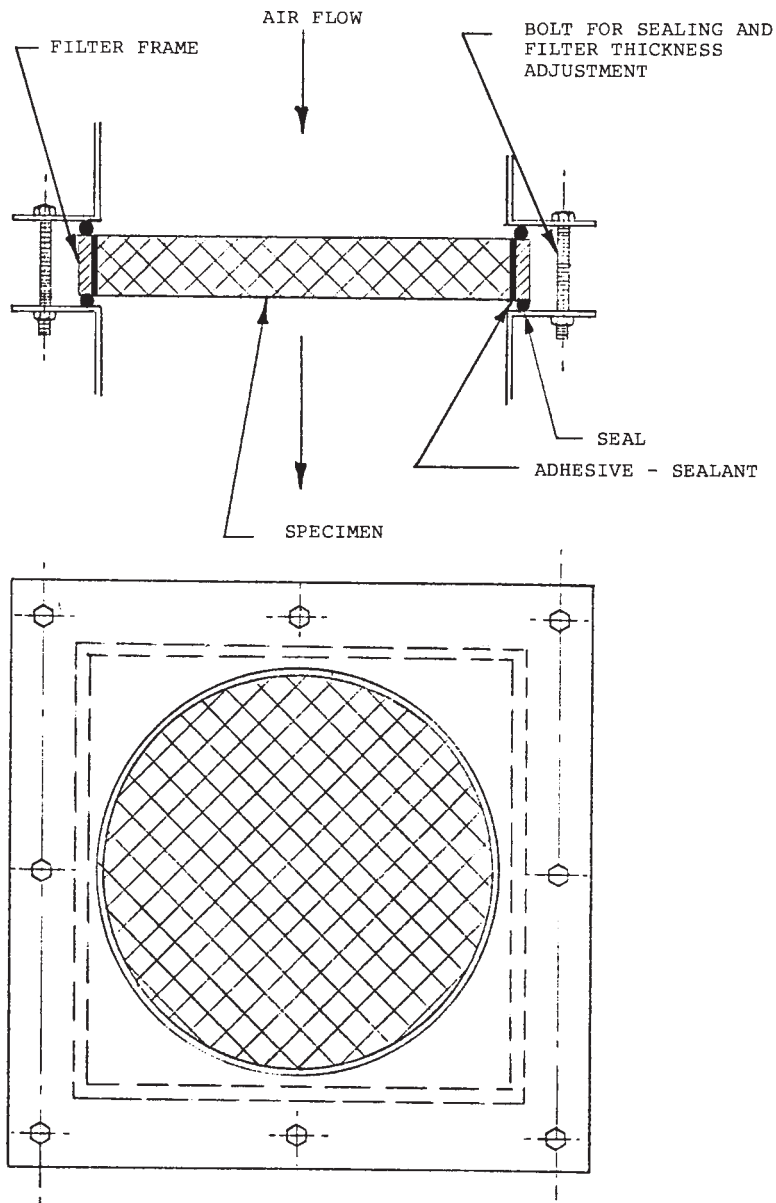

*ASTM International takes no position respecting the validity of any patent rights asserted in connection with any item mentioned in this standard. Users of this standard are expressly advised that determination of the validity of any such patent rights, and the risk of infringement of such rights, are entirely their own responsibility.*

*This standard is subject to revision at any time by the responsible technical committee and must be reviewed every five years and if not revised, either reapproved or withdrawn. Your comments are invited either for revision of this standard or for additional standards and should be addressed to ASTM International Headquarters. Your comments will receive careful consideration at a meeting of the responsible technical committee, which you may attend. If you feel that your comments have not received a fair hearing you should make your views known to the ASTM Committee on Standards, at the address shown below.*

*This standard is copyrighted by ASTM International, 100 Barr Harbor Drive, PO Box C700, West Conshohocken, PA 19428-2959, United States. Individual reprints (single or multiple copies) of this standard may be obtained by contacting ASTM at the above address or at 610-832-9585 (phone), 610-832-9555 (fax), or service@astm.org (e-mail); or through the ASTM website (www.astm.org).*