



Designation: D 5495 – 94 (Reapproved 2001)

## Standard Practice for Sampling With a Composite Liquid Waste Sampler (COLIWASA)<sup>1</sup>

This standard is issued under the fixed designation D 5495; the number immediately following the designation indicates the year of original adoption or, in the case of revision, the year of last revision. A number in parentheses indicates the year of last reapproval. A superscript epsilon ( $\epsilon$ ) indicates an editorial change since the last revision or reapproval.

### 1. Scope

1.1 This practice describes the procedure for sampling liquids with the composite liquid waste sampler, or “COLIWASA.” The COLIWASA is an appropriate device for obtaining a representative sample from stratified or unstratified liquids. Its most common use is for sampling containerized liquids, such as tanks, barrels, and drums. It may also be used for pools and other open bodies of stagnant liquid.

NOTE 1—A limitation of the COLIWASA is that the stopper mechanism may not allow collection of approximately the bottom inch of material, depending on construction of the stopper.

1.2 The COLIWASA should not be used to sample flowing or moving liquids.

1.3 *This standard does not purport to address all of the safety problems, if any, associated with its use. It is the responsibility of the user of this standard to establish appropriate safety and health practices and determine the applicability of regulatory limitations prior to use.*

### 2. Referenced Documents

#### 2.1 ASTM Standards:

- D 4687 Guide for General Planning of Waste Sampling<sup>2</sup>
- D 5088 Practice for Decontamination of Field Equipment Used at Nonradioactive Waste Sites<sup>3</sup>
- D 5283 Practice for Generation of Environmental Data Related to Waste Management Activities: Quality Assurance and Quality Control Planning and Implementation<sup>2</sup>

### 3. Summary of Practice

3.1 A clean device is slowly lowered into the liquid to be sampled. After it has filled, the bottom of the sampling tube is closed and the device is retrieved. The contents are subsequently discharged into a sample container.

### 4. Significance and Use

4.1 This practice is applicable to sampling liquid wastes and

other stratified liquids. The COLIWASA is used to obtain a vertical column of liquid representing an accurate cross-section of the sampled material. To obtain a representative sample of stratified liquids, the COLIWASA should be open at both ends so that material flows through it as it is slowly lowered to the desired sampling depth. The COLIWASA must not be lowered with the stopper in place. Opening the stopper after the tube is submerged will cause material to flow in from the bottom layer only, resulting in gross over-representation of that layer.

4.2 This practice is to be used by personnel acquiring samples.

4.3 This practice should be used in conjunction with Guide D 4687 which covers sampling plans, safety, QA, preservation, decontamination, labeling and chain-of-custody procedures; Practice D 5088 which covers decontamination of field equipment used at waste sites; and Practice E 5283 which covers project specifications and practices for environmental field operations.

### 5. Sampling Equipment

5.1 COLIWASAs are available commercially with different types of stoppers and locking mechanisms, but they all operate using the same principle. They can also be constructed from materials such as polyvinylchloride (PVC), glass, metal, or polytetrafluoroethylene (PTFE). A traditional model of the COLIWASA is shown in Fig. 1 [de Vera et al.]<sup>4-5</sup>; however, the design can be modified or adapted, or both, to meet the needs of the sampler. COLIWASAs must be selected that are constructed of materials compatible with the waste being sampled and with the analyses or tests to be performed. Due to the unknown nature of most containerized liquid wastes, COLIWASAs made of glass or polytetrafluoroethylene are best for general use.

### 6. Sample Containers

6.1 Plastic, glass or other nonreactive containers should be

<sup>1</sup> This practice is under the jurisdiction of ASTM Committee D34 on Waste Management and is the direct responsibility of Subcommittee D34.01.03 on Sample Preservation.

Current edition approved Jan. 15, 1994. Published March 1994.

<sup>2</sup> *Annual Book of ASTM Standards*, Vol 11.04.

<sup>3</sup> *Annual Book of ASTM Standards*, Vol 04.08.

<sup>4</sup> de Vera, E. R., Simmons, B. P., Stephens, R. C., and Storm, D. L., “Samplers and Sampling Procedures for Hazardous Waste Streams,” EPA-600/2-80-018, January 1980.

<sup>5</sup> Ford, P. J., Turina, P. J., and Seeley, D. E., “Characterization of Hazardous Waste Sites—A Methods Manual: Volume II,” Available Sampling Methods, Second Edition, EPA-600/4-84-076, December 1984.

**ASTM D 5495**

Pipe, PVC, translucent,  
4.13 cm (1 5/8") I.D.,  
4.76 cm (1 7/8") O.D.

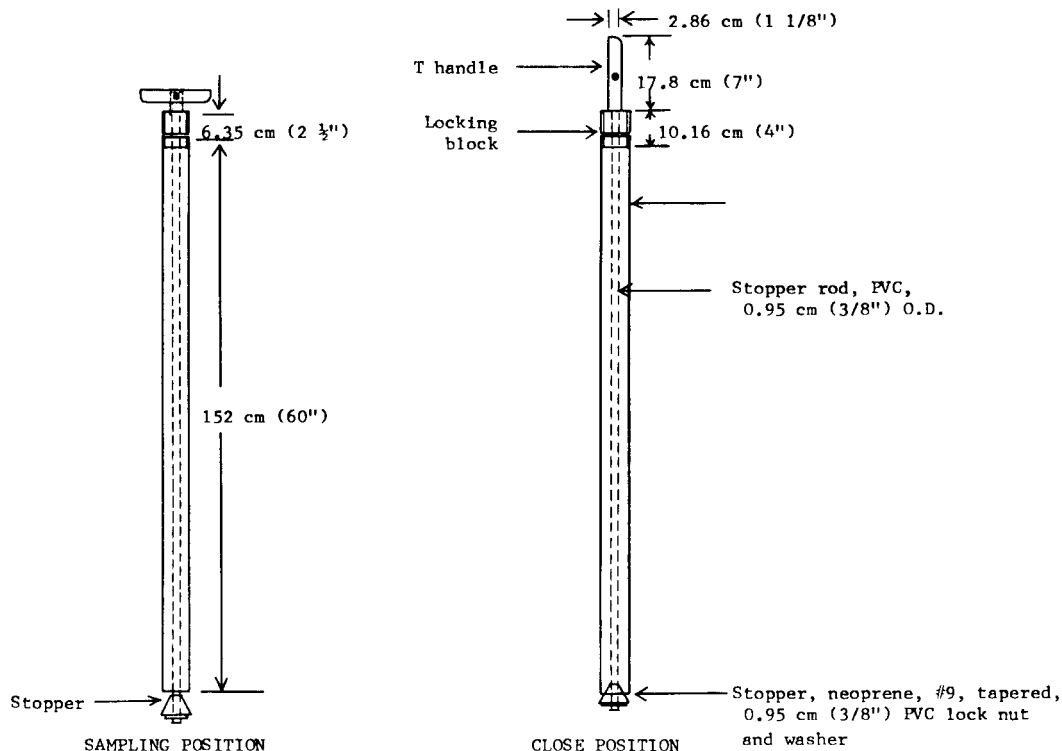

**FIG. 1 Composite Liquid Waste Sampler (COLIWASA) (Typical)**

used. Refer to Guide D 4687 for further information on containers.

**7. Procedure**

7.1 Make certain the COLIWASA is clean and functioning properly. It is essential that the stopper at the bottom of the sampling tube closes securely.

7.2 Open the COLIWASA by placing the stopper mechanism in the open position.

7.3 Lower the COLIWASA into the liquid slowly so that the levels of the liquid inside and outside the sampler tube remain about the same. If the level of the liquid in the sample tube is lower than that outside the sampler, the sampling rate is too fast and a nonrepresentative sample will result.

7.4 Use the stopper mechanism to close the COLIWASA when it reaches the desired depth in the liquid.

7.5 Withdraw the sampler from the liquid with one hand while wiping the sampler tube with a disposable cloth or rag with the other hand.

7.6 Carefully discharge the sample into a suitable container by slowly opening the stopper mechanism while the lower end of the COLIWASA is positioned in the sample container.

7.7 Seal the sample container; attach the label and seal; record in the field logbook; and complete the chain-of-custody record.

7.8 Decontaminate the used equipment in accordance with Practice D 5088.

**8. Keywords**

8.1 COLIWASA; drum sampling; liquid sampling; sampling; waste

*The American Society for Testing and Materials takes no position respecting the validity of any patent rights asserted in connection with any item mentioned in this standard. Users of this standard are expressly advised that determination of the validity of any such patent rights, and the risk of infringement of such rights, are entirely their own responsibility.*

*This standard is subject to revision at any time by the responsible technical committee and must be reviewed every five years and if not revised, either reapproved or withdrawn. Your comments are invited either for revision of this standard or for additional standards and should be addressed to ASTM Headquarters. Your comments will receive careful consideration at a meeting of the responsible technical committee, which you may attend. If you feel that your comments have not received a fair hearing you should make your views known to the ASTM Committee on Standards, at the address shown below.*

*This standard is copyrighted by ASTM, 100 Barr Harbor Drive, PO Box C700, West Conshohocken, PA 19428-2959, United States. Individual reprints (single or multiple copies) of this standard may be obtained by contacting ASTM at the above address or at 610-832-9585 (phone), 610-832-9555 (fax), or service@astm.org (e-mail); or through the ASTM website (www.astm.org).*