



Designation: D 5680 – 95a

Standard Practice for Sampling Unconsolidated Solids in Drums or Similar Containers¹

This standard is issued under the fixed designation D 5680; the number immediately following the designation indicates the year of original adoption or, in the case of revision, the year of last revision. A number in parentheses indicates the year of last reapproval. A superscript epsilon (ϵ) indicates an editorial change since the last revision or reapproval.

1. Scope

1.1 This practice covers typical equipment and methods for collecting samples of unconsolidated solids in drums or similar containers. These methods are adapted specifically for sampling drums having a volume of 110 U.S. gal (416 L) or less. These methods are applicable to hazardous material, product, or waste. Specific sample collection and handling requirements should be described in the site-specific work plan.

1.2 The values stated in inch-pound units are to be regarded as the standard. The values given in parentheses are for information only.

1.3 *This standard does not purport to address all of the safety concerns, if any, associated with its use. It is the responsibility of the user of this standard to establish appropriate safety and health practices and determine the applicability of regulatory limitations prior to use.*

2. Referenced Documents

2.1 ASTM Standards:

C 702 Practice for Reducing Samples of Aggregate to Testing Size²

D 4547 Practice for Sampling Waste and Soils for Volatile Organics³

D 4687 Guide for General Planning of Waste Sampling³

D 4700 Guide for Soil Sampling from the Vadose Zone⁴

D 5088 Practice for the Decontamination of Field Equipment Used at Non-Radioactive Waste Sites⁴

D 5283 Practice for Generation of Environmental Data Related to Waste Management Activities: Quality Assurance and Quality Control Planning³

D 5451 Practice for Sampling with a Trier Sampler³

E 300 Practice for Sampling Industrial Chemicals⁵

D 5633 Practice for Sampling With a Scoop³

2.2 NSC Document:

Accident Prevention Manual for Industrial Operations, 1992⁶

2.3 Government Documents:⁷

Drum Handling Practices at Hazardous Waste Sites, EPA/600/2-86/013, January 1986

Soil Sampling and Analysis for Volatile Compounds, EPA/540/4-91/001, February 1991

Occupational Safety and Health Guidance Manual for Hazardous Waste Site Activities, National Institute for Occupational Safety and Health (NIOSH), Occupational Safety and Health Administration (OSHA), U.S. Coast Guard (USCG), and U.S. Environmental Protection Agency (EPA), October 1985

3. Terminology

3.1 Definitions:

3.1.1 *bonding*—touching the sample equipment to the drum to form an electrically conductive path to minimize potential electrical differences between the sampling equipment and the drum, reducing the buildup of static electricity.

3.1.2 *bung*—usually a 2-in. (5.1-cm) or 3/4-in. (1.3-cm) diameter threaded plug designed specifically to close a bung hole.

3.1.3 *bung hole*—an opening in a barrel or drum through which it can be filled, emptied, or vented.

3.1.4 *deheading*—removal of the lid of a closed-head drum; usually accomplished with a drum deheader.

3.1.5 *drum*—implies any drum, barrel, or non-bulk container of 5 to 110 U.S. gal (19 to 416 L) capacity.

3.1.6 *pail*—a small container, usually with a capacity of 5 U.S. gal. Pails typically have bungs or spouts, or the entire lid can be removed.

3.1.7 *paperwork*—all required site documentation, which may include the manifests, waste profiles, material safety data sheets (MSDS), site forms, sample labels, custody seals, and chain of custody forms.

3.1.8 *unconsolidated*—for solid material, the characteristic of being uncemented or uncompacted, or both, and separated easily into smaller particles.

3.1.9 *work plan*—a plan specific to a particular site; for conducting activities specified in the plan.

¹ This practice is under the jurisdiction of ASTM Committee D-34 on Waste Management and is the direct responsibility of Subcommittee D34.01 on Sampling and Monitoring.

Current edition approved June 15, 1995. Published August 1995. Originally published as D 5680 – 95. Last previous edition D 5680 – 95.

² *Annual Book of ASTM Standards*, Vol 04.02.

³ *Annual Book of ASTM Standards*, Vol 11.04.

⁴ *Annual Book of ASTM Standards*, Vol 04.08.

⁵ *Annual Book of ASTM Standards*, Vol 15.05.

⁶ Available from National Safety Council, P.O. Box 558, Itasca, IL 60143-0558.

⁷ Available from the Superintendent of Documents, U. S. Government Printing Office, Washington, DC 20402.

4. Summary of Practice

4.1 The drum and its contents are inspected, and appropriate sampling equipment is selected. A clean sampling device is then used to auger, scoop, or core into the unconsolidated solid material to be sampled. The sample is collected and placed in a sample container. The sampling device is then either disposed of or cleaned and decontaminated.

5. Significance and Use

5.1 This practice is intended for use in collecting samples of unconsolidated solid materials from drums or similar containers, including those that are unstable, ruptured, or compromised otherwise. Special handling procedures (for example, remote drum opening, overpressurized drum opening, drum deheading, etc.) are described in *Drum Handling Practices at Hazardous Waste Sites*.

6. Interferences

6.1 The condition of the materials to be sampled and the condition and accessibility of the drums will have a significant impact on the selection of sampling equipment.

7. Pre-Sampling

7.1 General Principles and Precautions:

7.1.1 Samples should be collected in accordance with an appropriate work plan (Practice D 5283 and Guide D 4687). This plan must include a worker health and safety section because there are potential hazards associated with opening drums as well as potentially hazardous contents. See *Occupational Safety and Health Guidance Manual for Hazardous Waste Site Activities* for information on health and safety at hazardous waste sites.

7.1.2 Correct sampling procedures must be applied to the conditions as they are encountered. It is impossible to specify rigid rules describing the exact manner of sample collection because of unknowns associated with each solid sampling situation. It is essential that the samples be collected by a trained and experienced sampler because of the various conditions under which drummed solids must be sampled.

7.1.3 To be able to make probability or confidence statements concerning the properties of a sampled lot, the sampling procedure must allow for some element of randomness in selection because of the possible variations in the material. The sampler should always be on the alert for possible biases arising from the use of a particular sampling device or from unexpected segregation within the material.

7.1.4 All auger, trier, thief, and scoop methods may fail a prime sampling requirement: that of random selection of sample fractions. Scoops are limited to use at or near the top surface. Augers, triers, and thieves are normally inserted in a present pattern. Particles on the bottom or along the sides of the drum may consequently never have an opportunity to be included in a sample. Sample particles should be selected by techniques that will minimize variation in measured characteristics between the available fractions and the resulting sample (Practice C 702).

7.1.5 The sampling equipment, sample preparation equipment, sample containers, etc. must be clean, dry, and inert to the material being sampled. All equipment, including sample

containers, shall be inspected before use to ensure that they are clear of obvious dirt and contamination and are in good working condition. Visible contamination shall be removed, and the equipment shall be decontaminated with the appropriate rinse materials. Decontaminated sampling equipment should be protected from contamination. This may include, but not be limited to, storage in aluminum foil, plastic bags, polytetrafluoroethylene (PTFE) film, or other means of protection that will not impact the sample quality of intended analysis.

7.2 Basic Pre-Sampling Practices:

7.2.1 Review all paperwork.

7.2.2 Select the sampling equipment and sample containers appropriate for the material in the drum, as detailed in the work plan.

7.2.3 Enter the work zone.

7.2.4 Inspect all drums to be sampled visually. Note any abnormal conditions, including rust marks, stains, bulges, or other signs of pressurization or leaks that may require special handling. The work plan should define clearly the limiting condition under which special handling procedures shall be initiated. See *Drum Handling Practices at Hazardous Waste Sites* for information on opening overpressurized drums and the use of remotely operated drum opening equipment.

7.2.5 Stage the drums to be sampled in a designated work area if they cannot be sampled in their current location. See *Drum Handling Practices at Hazardous Waste Sites* for further information on staging turns.

7.2.5.1 Move the drums to upright, stable positions if necessary. Sufficient space shall be left between drums to prevent movement hazards.

7.2.5.2 Number or identify uniquely all drums to be sampled.

7.2.6 Perform a detailed inspection of individual drums.

7.2.6.1 Record all relevant information from drum labels, markings, data sheets, etc. in the field log book or on forms specified in the work plan.

7.2.6.2 Make sure there are no discrepancies with existing paperwork.

7.2.7 Slowly loosen the ring that secures the lid, or loosen the bung allowing any pressure or vacuum to equalize.

7.2.7.1 Precautionary Notes:

(1) If the drum or pail appears to be under positive or negative pressure (that is, a slight bulge or dimple in the lid), control the release of pressure until it has equalized. For example, if the drum or pail is equipped with bungs, loosen the smaller bung first since doing so will make it easier to control the release of pressure.

(2) If the top of the drum is dished inward (dimpled), it may “pop” when equalizing pressure, spraying the sampler with any material that is sitting on top of the drum.

(3) If there is evidence of a chemical reaction or sudden pressure buildup, the sampler should leave the area immediately and evaluate whether remote drum opening equipment should be used.

(4) For flammable or explosive materials, the drum and sampling equipment should be grounded if the generation of static electricity while opening or sampling the drum is a

possibility. The drum and sampling equipment should be grounded to a ground stake or to an existing ground (building ground, grounded water pipes, etc.). New sampling equipment may have some residual static electrical charge due to the materials in which they are packed and shipped. The work plan should specify whether grounding is necessary. See *Accident Prevention Manual for Industrial Operations* for information on grounding and bonding.

7.2.7.2 Drums should be opened, sampled, and closed individually to minimize the risk of exposure.

7.2.7.3 *Drums (or Pails) with Bungs*—Loosen the large bung slowly. Use non-sparking tools.

7.2.7.4 *Drums with Removable Lids*—Loosen the ring slowly with a manual wrench or air impact wrench. Use non-sparking tools.

7.2.7.5 *Pails with Removable Lids (Side-Lever Lock Ring)*—Release the lever slowly.

7.2.7.6 *Pails with Removable Lids (Snap-On)*—Pry the lid loose slowly with a pail lid opener.

7.2.8 Manual or remote puncturing or deheading will be required if the drum (or pail) has a stuck bung or the lid cannot be removed. See *Drum Handling Practices at Hazardous Waste Sites* for further information on manual or remote drum opening.

7.2.9 Any discrepancy discovered (such as evidence of free liquid) upon opening the drum should be recorded in the field log book.

7.3 *Sampling Equipment—Selection:*

7.3.1 Table 1 summarizes selection criteria for equipment by the material to be sampled.

7.3.2 *Sampling Equipment, Materials of Construction*—Sampling devices will usually be made of stainless steel, brass, or aluminum. Devices using permanent coatings or liners (such as PTFE) may be subject to abrasion, leading to contamination of the sample.

7.3.3 *Generic Equipment List*—A general list of equipment used for sampling unconsolidated solids follows:

- 7.3.3.1 Scoop.
- 7.3.3.2 Trier.
- 7.3.3.3 Auger.
- 7.3.3.4 Concentric tube thief (single slot, multi-slot, grain probe, and missouri trier).
- 7.3.3.5 Thin-walled tube.
- 7.3.3.6 Scissors.
- 7.3.3.7 Tong.

- 7.3.3.8 Hammer and chisel.
 - 7.3.3.9 Cloths or wipes, or both.
 - 7.3.3.10 Spatula.
 - 7.3.3.11 Sample containers, lids, and liners.
 - 7.3.3.12 Chain of custody forms.
 - 7.3.3.13 Field log books.
 - 7.3.3.14 Sample labels.
 - 7.3.3.15 Sample cooler.
 - 7.3.3.16 Ice or gel ice.
 - 7.3.3.17 Grounding cables with alligator clips and emery cloth.
 - 7.3.3.18 Portable monitoring equipment (combustible gas indicator, organic vapor detectors, radiation survey meter, etc.).
- 7.3.4 Equipment needed to open drums should be non-sparking (brass or beryllium copper) and include, but not be limited to, the following:
- 7.3.4.1 Bung wrenches (one straight and one bent),
 - 7.3.4.2 Flatblade screwdriver,
 - 7.3.4.3 Breaker bar (½ in. (1.3 cm)),
 - 7.3.4.4 Ratchet (½ in. (1.3 cm)),
 - 7.3.4.5 Speed handle (½ in. (1.3 cm)),
 - 7.3.4.6 Adjustable wrenches (10 and 12 in. (25 and 30 cm)),
 - 7.3.4.7 Air impact wrench and sockets, and
 - 7.3.4.8 Pail lid opener.

8. **Sample Collection**

8.1 *Basic Sampling Practices:*

- 8.1.1 Bond the sampling equipment to the drum, if specified in the work plan.
- 8.1.2 Note the physical characteristics, including any discrepancies (such as free liquid).
- 8.1.3 Collect the required number of samples from the drum.
 - 8.1.3.1 See Practice D 4547 and *Soil Sampling and Analysis for Volatile Compounds* for the collection of samples for volatile analysis.
- 8.1.4 Place the collected material in a sample container.
- 8.1.5 Close the sample container.
- 8.1.6 Wipe the outside of the sample container. Dispose of the wipe cloth properly.
- 8.1.7 Record in the field log book all relevant conditions and physical characteristics associated with the collection of each sample.
- 8.1.8 Fill out all required paperwork for each sample, as required by the work plan.
- 8.1.9 Complete and attach the label to the side of the sample container before or after sampling, as directed by the work plan. The sample label should include the following:
 - (1) Sample ID number,
 - (2) Name of sampler,
 - (3) Sampler’s initials or signature,
 - (4) Date and time of sampling, and
 - (5) Sample location.
 - 8.1.9.1 The sample label can also include the following:
 - (1) Sampling information (for example, grab, composite, etc.),
 - (2) Preservative and preservation required,
 - (3) Special instructions, and
 - (4) Analysis request.

TABLE 1 Selection Criteria for Equipment

Equipment	ASTM Standard	Cohesive Solid	Sheet, Cloth, or Chunk Material	Dry Flowable Solids	Moist Flowable Solids
Scoop	D 5633	X ^A	X	X	X
Auger	D 4700	X	... ^B
Trier	D 5451	X	X
Thin-walled tube	D 4700	...	X ^C	X ^C	...
Hammer and chisel		N ^D	N
Scissors and tongs		...	X
Concentric tube thief	E 300	X	...

^A X = equipment may be used with this type of waste.
^B Equipment is probably unsuitable.
^C Sampling equipment with retaining device.
^D N = not equipment of choice, but may be used.

8.2 Sampling Using a Scoop:

8.2.1 *General Description*—A plastic or metal scoop is used for collecting approximately equal fractions at random intervals at or near the surface of the material (see Fig. 1). This sampling tool should be of a size and shape suitable for the quantity and size of the particles to be sampled. Scoop sampling provides best results if the material is uniform.

8.2.2 *Operation and Use*—A thin layer of material is removed with the scoop and discarded. A suitable volume of material is collected with the scoop and transferred to a sample container.

8.3 Sampling with a Thin-Walled Tube Sampler:

8.3.1 This sampler can be used to collect samples of unconsolidated material that is usually moist or cohesive and may be powdery or granular.

8.3.2 *General Description*—Tube samplers may vary in diameter, length, and material of construction (see Fig. 2). The material to be sampled must be of a physical consistency (cohesive solid material) to be cored and retrieved with the tube. Materials with particles larger than one-third of the inner diameter of the tube should not be sampled with this particular device. The length of the tube will depend on the desired sampling depth (Guide D 4700). The tube is attached to a length of a solid or tubular rod. The upper end of this rod is threaded to accept a handle or extension rods. This sampler can be used to collect samples of unconsolidated clay-like materials.

8.3.3 *Operation and Use*—The sampler is pushed into the material to be sampled by applying downward force on the unit's handle. Once the sampler has reached the bottom of the sampling interval, it is twisted to break the continuity at the tip. The sampler is pulled from the material, and the sample material is extruded into the sample container. Samples are extruded by forcing a rod through the tube.

8.4 Sampling with a Trier Sampler:

8.4.1 *General Description*—The trier is a metal or plastic tube from which one-third to one-half of the wall of the tube has been removed to form a slot along its entire length (see Fig. 3). This device can be up to 4 ft (1.2 m) long and should have a sharp, angled point at its lower end. The trier can be used as a coring device in drums of solids such as soils and similar fine-grained cohesive materials.

8.4.2 *Operation and Use*—The trier is pushed vertically into the material and rotated one or two times to cut a core. The core is pulled out of the hole and transferred to a sample

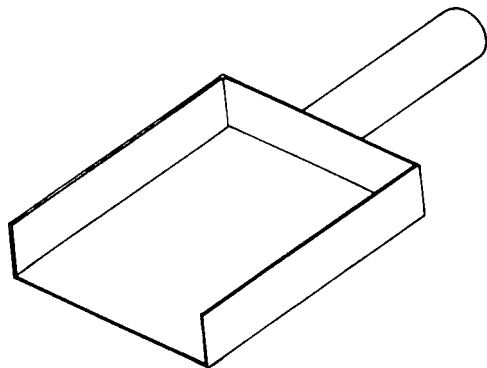

FIG. 1 Scoop

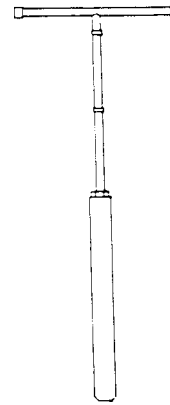

FIG. 2 Thin-Walled Tube Sampler

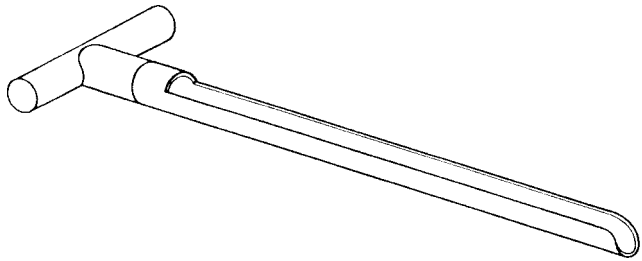

FIG. 3 Trier

container (Practice D 5451).

8.5 Sampling with an Auger:

8.5.1 *General Description*—The screw or ship auger is essentially a small-diameter (for example, 1.5-in. (3.8-cm)) wood auger from which the cutting side flanges and tip have been removed. The auger is welded onto a length of solid or tubular rod. The upper end of this rod is threaded to accept a handle or extension rods. An auger can be used for collecting a disturbed sample of unconsolidated material in drums (see Fig. 4 and Guide D 4700).

8.5.2 *Operation and Use*—The auger is rotated manually or with a power source into the material to be sampled. The operator may have to apply downward force to embed the auger; the auger screws itself into the material afterwards. The auger is advanced to its full length and then pulled and removed. Material from the deepest interval is retained on the auger flights. Sample material can be collected from the flights using a spatula.

8.6 Sampling with a Hammer and Chisel, Scissors, or Tongs:

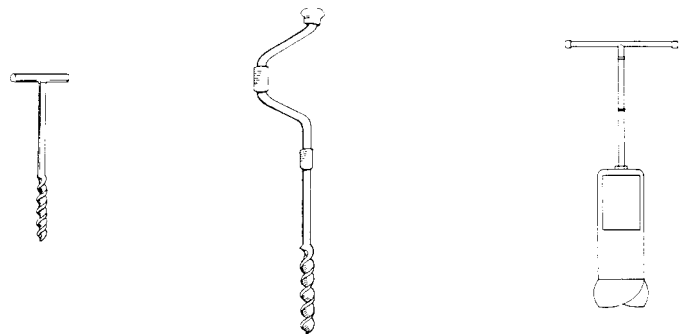

FIG. 4 Augers (Typical)

8.6.1 *General Description*—A hammer is used to impact a hardened steel chisel to break the unconsolidated material into chips, flakes, and chunks suitable for collection with a scoop. Scissors are used in combination with tongs to collect samples of material that are clothlike, elastic, paperlike, etc.

8.6.2 *Operation and Use*—These tools are used as necessary to collect sample material from the drum. A hammer and chisel have been found useful in sampling drums for which particle size reduction is necessary. This method is not recommended for samples requiring volatile organics analysis.

8.7 *Sampling with a Concentric Tube Thief:*

8.7.1 *General Description*—This device consists of two tubes, one fitting snugly inside the other (see Fig. 5). The bottom end of the outer tube is fitted with a point. Oblong holes are cut through both tubes. The holes are opened or closed by rotating the inner tube. They are constructed as either single compartment (single-slot and multi-slot tube thieves) or multiple compartment (Missouri trier or Grain Probe) sampling devices. Concentric tube thieves are commercially available up to 6 ft (1.8 m) long and several in. (cm) in diameter. Concentric tube thieves have a limited application for sampling drums. Material that is not free-flowing, such as those that are hard packed, moist, or finely powdered, will not enter this sampler under normal field conditions. Sampling of materials containing granules or particles exceeding one-third of the slot width should not be attempted because bridging may occur. These devices cannot sample the bottom of a drum because of their pointed ends.

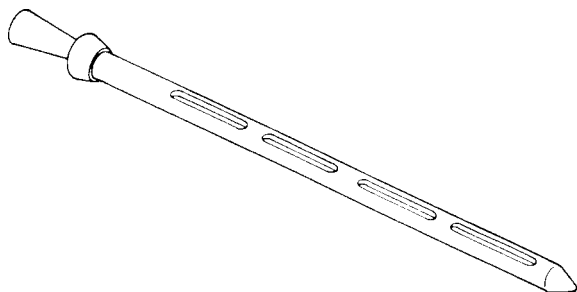

FIG. 5 Concentric Tube Thief

The American Society for Testing and Materials takes no position respecting the validity of any patent rights asserted in connection with any item mentioned in this standard. Users of this standard are expressly advised that determination of the validity of any such patent rights, and the risk of infringement of such rights, are entirely their own responsibility.

This standard is subject to revision at any time by the responsible technical committee and must be reviewed every five years and if not revised, either reapproved or withdrawn. Your comments are invited either for revision of this standard or for additional standards and should be addressed to ASTM Headquarters. Your comments will receive careful consideration at a meeting of the responsible technical committee, which you may attend. If you feel that your comments have not received a fair hearing you should make your views known to the ASTM Committee on Standards, 100 Barr Harbor Drive, West Conshohocken, PA 19428.

This standard is copyrighted by ASTM, 100 Barr Harbor Drive, West Conshohocken, PA 19428-2959, United States. Individual reprints (single or multiple copies) of this standard may be obtained by contacting ASTM at the above address or at 610-832-9585 (phone), 610-832-9555 (fax), or service@astm.org (e-mail); or through the ASTM website (<http://www.astm.org>).

8.7.2 *Operation and Use*—Insert the tube into the material, and push with uniform force to the bottom of the drum or until refusal. Rotate the concentric tubes to the open position, thereby allowing the sample to flow into the inner tube. Wiggle the sampler several times, and rotate the tubes to the closed position. Withdraw the sampler. Place the sampling device immediately over a sample collection sheet, and release the sample by rotating the concentric tubes to the open position. A sample can normally be removed from the thief with a spatula or similar instrument (reamer) and placed in the sample container.

9. Post-Sampling

9.1 Remove all sampling equipment from the work zone.

9.2 Transfer all reusable equipment that was in contact with the waste to a pre-designated decontamination area. Decontaminate the equipment according to the protocol established in the work plan (Practice D 5088). Decontaminated sampling equipment should be protected from contamination. This may include, but not be limited to, storage in aluminum foil, plastic bags, PTFE film, or other means of protection that will not impact the sample quality or intended analysis.

9.3 Dispose of all used (disposable) contacting equipment.

10. Data Quality Objectives

10.1 The objectives for sampling and testing of unconsolidated solid material should be specified in the work plan.

11. Quality Control

11.1 Quality control (QC) (for example, equipment blanks, trip blanks, and duplicates) must be collected as required by the work plan. These QC samples shall be evaluated to provide a determination of the sampling quality and reliability of the resulting analytical data.

12. Keywords

12.1 Auger; concentric tube thief; scoop; thin-wall tube; trier; unconsolidated solids; waste