



Standard Practice for Sampling Liquids Using Grab and Discrete Depth Samplers¹

This standard is issued under the fixed designation D 6759; the number immediately following the designation indicates the year of original adoption or, in the case of revision, the year of last revision. A number in parentheses indicates the year of last approval. A superscript epsilon (ϵ) indicates an editorial change since the last revision or reapproval.

1. Scope

1.1 This practice describes sampling devices and procedures for collecting samples of liquids or sludges, or both, whose upper surface can be accessed by the suitable device. These devices may be used to sample tanks that have an appropriately sized and located sampling port.

1.2 This practice describes and discusses the advantages and limitations of the following commonly used equipment, some of which can be used for both grab and discrete depth sampling: dipper, liquid grab sampler, swing jar sampler, Bacon Bomb, Kemmerer sampler, Discrete Level sampler, liquid profiler, lidded sludge/water sampler, peristaltic pump, and the Syringe sampler.

1.3 This practice provides instructions on the use of these samplers.

1.4 This practice does not address sampling devices for collecting ground water.

1.5 *This standard does not purport to address all of the safety concerns, if any, associated with its use. It is the responsibility of the user of this standard to establish appropriate safety and health practices and determine the applicability of regulatory limitations prior to use.*

2. Referenced Documents

2.1 ASTM Standards:²

- D 4687 Guide for General Planning of Waste Sampling
- D 4840 Guide for Sample Chain of Custody Procedures
- D 5088 Practice for Decontamination of Field Equipment Used at Non-Radioactive Waste Sites
- D 5283 Practice for Generation of Environmental Data Related to Waste Management Activities: Quality Assurance and Quality Control Planning and Implementation
- D 5358 Practice for Sampling with a Dipper or Pond Sampler
- D 5743 Practice for Sampling Single or Multilayered Liquids with or without Solids in Drums or Similar Containers

- D 5753 Guide for Planning and Conducting Borehole Geophysical Logging
- D 5792 Practice for Generation of Environmental Data Related to Waste Management Activities: Development of Data Quality Objectives
- D 5956 Guide for Sampling Strategies for Heterogeneous Wastes
- D 6044 Guide for Representative Sampling for Management of Waste and Contaminated Media
- D 6051 Guide for Composite Sampling and Field Subsampling for Environmental Waste Management Activities
- D 6232 Guide for Selection of Sampling Equipment for Waste and Contaminated Media Data Collection Activities
- D 6323 Guide for Laboratory Subsampling of Media Related to Waste Management Activities
- D 6538 Guide for Sampling Wastewater With Automatic Samplers
- D 6699 Practice for Sampling Liquids Using Bailers
- E 856 Definitions of Terms and Abbreviations Relating to Physical and Chemical Characteristics of Refuse Derived Fuel

3. Terminology

3.1 *discrete depth sample, n*—sample obtained from a defined level within the liquid being sampled.

3.2 *grab sample, n*—individual sample collected over a period of time usually not exceeding 15 min and in such a manner as to be representative of conditions at the time of sampling. Grab samples are sometimes called individual or discrete samples.

3.3 *representative sample, n*—sample collected such that it reflects one or more characteristics of interest (as defined by the project objectives) of a population from which it was collected. **D 5956**

3.4 *sample, n*—portion of material taken from a larger quantity for the purpose of estimating properties or composition of the larger quantity. **E 856**

3.5 *sludge, n*—any mixture of solids that settles out of solution. Sludges contain liquids that are not apparent as free liquids (see Practice D 5743). **D 6323**

¹ This practice is under the jurisdiction of ASTM Committee D34 on Waste Management and is the direct responsibility of Subcommittee D34.01.03 on Sampling Equipment.

Current edition approved Feb. 10, 2002. Published May 2002.

² For referenced ASTM standards, visit the ASTM website, www.astm.org, or contact ASTM Customer Service at service@astm.org. For *Annual Book of ASTM Standards* volume information, refer to the standard's Document Summary page on the ASTM website.

4. Significance and Use

4.1 Sampling at specified depth(s) within a liquid may be needed to confirm or rule out variations within a target population. This practice describes the design and operation of commercially available grab and discrete depth samplers for persons responsible for designing or implementing sampling programs, or both.

4.2 These sampling devices are used for sampling liquids in tanks, ponds, impoundments, and other open bodies of water. Some may be used from the edge or bank of the sampling site, whereas some can only be used from a platform, boat, or bridge over the sampling site. Some of the devices described are suitable for sampling slurries and sludges as well as aqueous and other liquids with few or no suspended solids.

4.3 Practice D 5743 provides guidance for sampling drums, tanks, or similar containers.

4.4 This practice does not address general guidelines for planning waste sampling activities (Guide D 4687), development of data quality objectives (Practice D 5792), the design of monitoring systems and determination of the number of samples to collect (Practice D 6311), in situ measurement of parameters of interest, data assessment and statistical interpretation of resultant data (Guide D 6233), sample preservation, sampling and field quality assurance (Guide D 5612), or the selection of sampling locations or obtaining a representative sample (Guide D 6044).

5. Pre-Sampling

5.1 Samples should be collected in accordance with an appropriate work plan (Practice D 5283 and Guide D 4687) and in accordance with the Data Quality Objectives (Practice D 5792). The plan should include a worker health and safety section because of the potential hazards associated with sampling wastes.³

5.2 All equipment shall be clean, dry, and compatible with the anticipated composition of the material being sampled (Practice D 5088). When sampling a hazardous material, if the exterior of the sample bottle or sampling apparatus contacts the hazardous material, it needs to be cleaned before subsequent steps, such as labelling or sample transfer, are taken.

5.3 For samplers with long handles, if high voltage electrical wires could come into contact with the handle, the handle should be made of nonconductive material, such as wood.

5.4 For guidance in obtaining a representative sample, see Guide D 6044.

5.5 For guidance in how to prepare composite samples and subsamples in the field, see Guide D 6051.

5.6 Some discrete samples can be taken using bailers (see Practice D 6699). Additional information on selecting sampling equipment, based on the sample matrix, and the constraints on the use of equipment, based on the physical and chemical properties of the equipment, can be found in Guide D 6232.

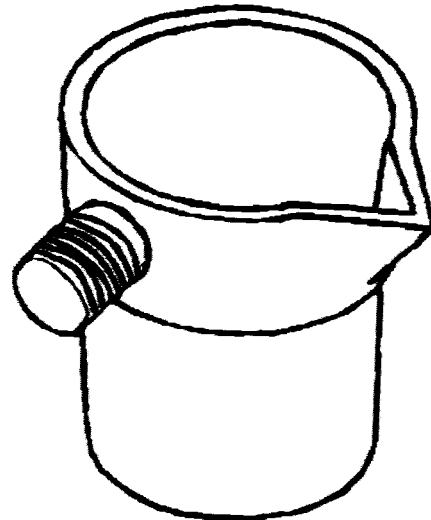

FIG. 1 Dipper

6. Sampling Equipment and Procedures

6.1 Dipper:

6.1.1 *Description*—A dipper can consist of a variety of pieces of equipment assembled in a manner to obtain a sample.

6.1.1.1 One type has an adjustable clamp attached to the end of a metal rod or tube, which may be extendable (see Fig. 1). The rod or tube forms the handle and the clamp is used to secure it to a beaker or other sample container.

6.1.1.2 Another type of device is made using a stainless steel tube clamped to a moveable bracket that is attached to a rigid handle. The angle of the cup to the handle is adjustable (Practice D 5358).

6.1.2 Procedure:

6.1.2.1 With the beaker facing downward, lower the dipper beaker into the liquid slowly until it is submerged. Try to cause a minimum of surface disturbance.

6.1.2.2 Rotate the beaker through 180°. If there is a current, the mouth of the beaker should face upstream during the rotation.

6.1.2.3 Allow the beaker to fill.

6.1.2.4 Slowly bring it to the surface.

6.1.2.5 Transfer the sample, usually by gently pouring the dipper's contents into a clean sample container.

6.1.3 Advantages and Limitations:

Advantages	Limitations
It is inexpensive.	It can be used to obtain only surface samples.
When attached to a rigid pole, it can reach to 4 m (10–13 ft) away from the person collecting samples.	Because the sample collection chamber is always open, it cannot obtain a sample containing the same strata proportions as the strata at the location being sampled.

6.2 Liquid Grab Sampler:

6.2.1 *Description*—A liquid grab sampler consists of a rigid handle with a bottle attached to one end. The bottle is sealed with a plunger that can be opened or closed by moving the cable that is attached to it (see Fig. 2).

6.2.2 *Procedure*—Assemble the liquid grab sampler per the manufacturer's instructions.

³ Occupational Safety and Health Guidance Manual for Hazardous Waste Site Activities, DHHS (NIOSH) Publication No. 85-115 (NTIS No. PB87-162855/LL), NIOSH, OSHA, USCG, EPA, October 1985.

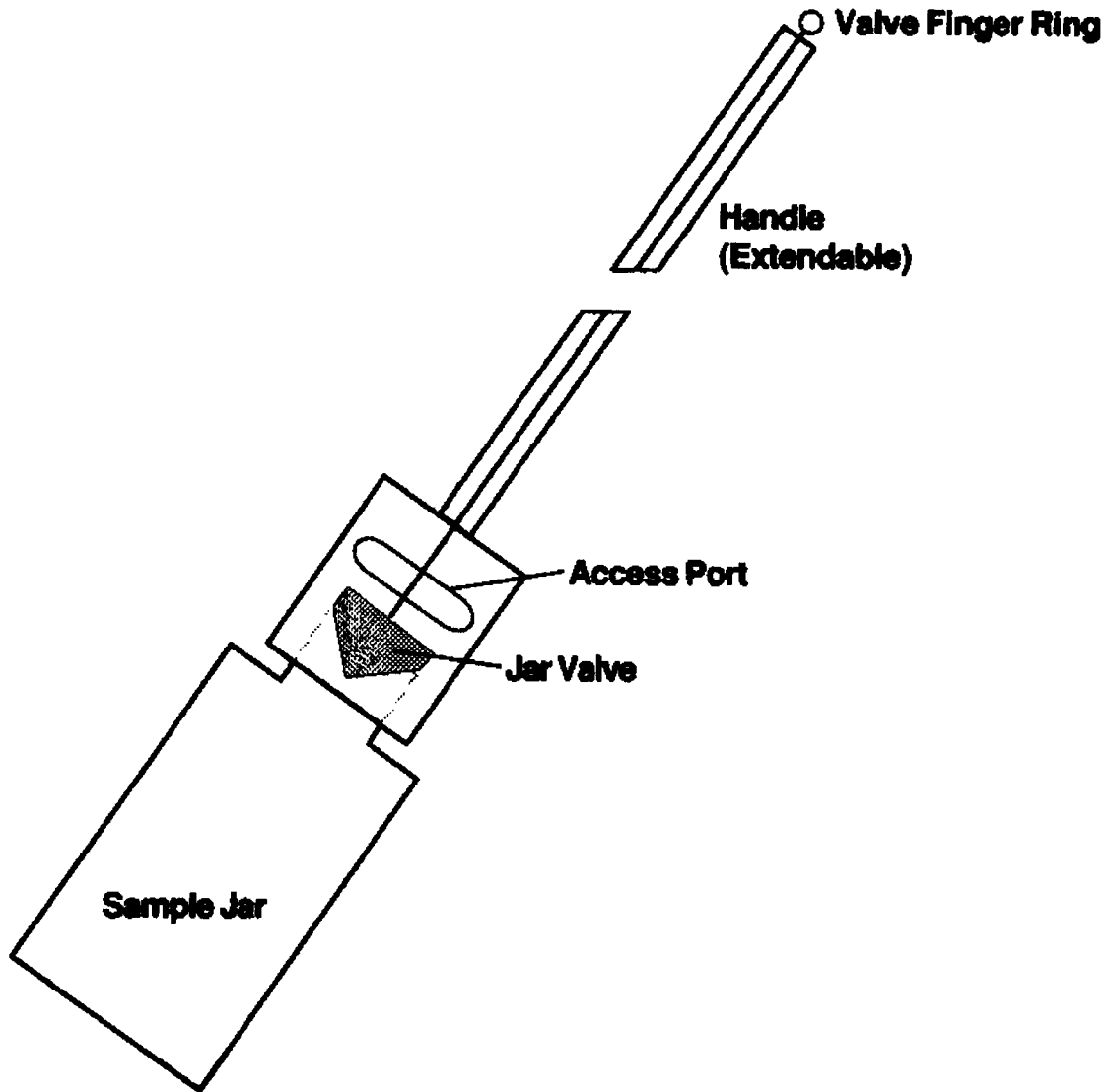

FIG. 2 Liquid Grab Sampler

6.2.2.1 When assembled, thread the bottle onto the grab sampler head and tighten by turning the bottle clockwise.

6.2.2.2 Submerge the sampler to the desired depth and pull the split key ring to allow liquid to enter the bottle.

6.2.2.3 Release the ring to close the bottle.

6.2.2.4 Raise the sampler from the liquid.

6.2.2.5 Remove the filled sample bottle and seal it.

6.2.2.6 Clean the outside surface of the sample bottle.

6.2.3 *Advantages and Limitations:*

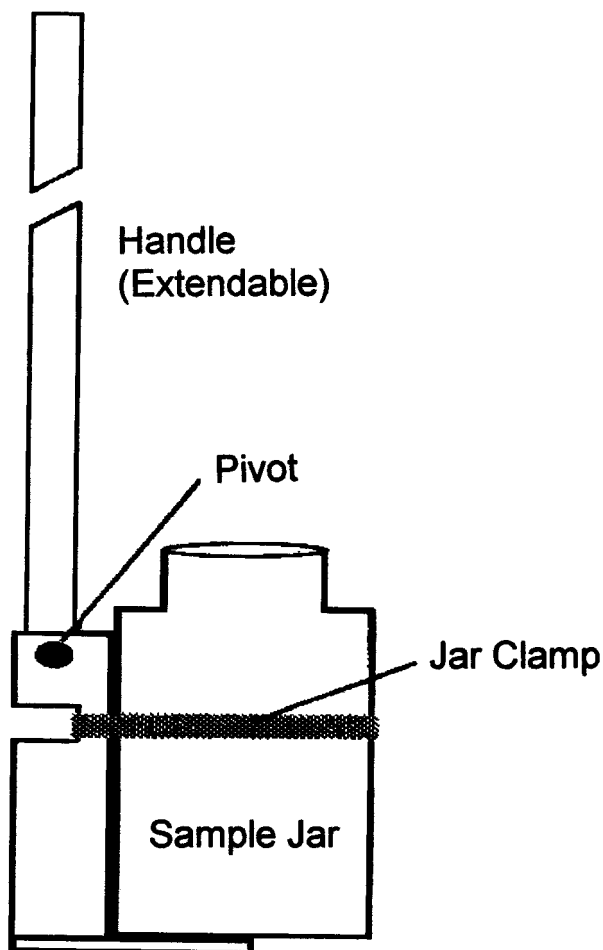

FIG. 3 Swing Jar Sampler

Advantages
 The sample jar is available commercially in a range of materials, providing the choice of one that is chemically inert to the contaminants of interest.
 Handles of various lengths can be used to obtain samples from different depths.
 The sample does not need to be transferred to another container for shipping.
 The sampler is not opened until the desired sampling depth is reached, that is, it can be used as a discrete depth sampler (see Practice D 6699).

Limitations
 True depth of sample unknown unless device is vertically deployed.
 Not able to collect stratified samples of proper proportions.
 Exterior of sample bottle needs cleaning after immersion in hazardous waste.

6.3 Swing Jar Sampler:

6.3.1 Description—This sampling device consists of a pole that screws into a bottle holder (see Fig. 3). The angle of the bottle with respect to the pole can be varied.

6.3.2 Procedure:

6.3.2.1 Select the bottle clamp that best fits the desired sample bottle.

6.3.2.2 Connect the pole to the bottle holder and turn it clockwise until snug.

6.3.2.3 Slide the clamp onto the bottle to a point midway between the bottle shoulder and heel.

6.3.2.4 Tighten the screw located in the inner pole screw threads of the bottle holder.

6.3.2.5 Lower the sampler into the liquid slowly with the bottle facing downward until it is submerged to cause minimal surface disturbance.

6.3.2.6 Rotate the bottle through 180°.

NOTE 1—If there is a current, the mouth of the bottle should face upstream during the rotation.

6.3.2.7 Allow the bottle to fill and slowly bring it to the surface.

6.3.2.8 Loosen the screw holding the bottle to the device.

6.3.2.9 Remove the bottle from the holder.

6.3.2.10 For transport to the laboratory, either seal the bottle and clean the exterior or transfer the bottle's contents into a clean sample container.

6.3.3 Advantages and Limitations:

Advantages	Limitations
The sampler can accommodate different sample bottle sizes up to 960 mL.	Not suitable for discrete depth sampling.
It allows collection from various angles, including vertical.	Exterior of sample bottle needs cleaning after immersion in hazardous waste.

6.4 Bacon Bomb:

6.4.1 Description—The Bacon Bomb sampler consists of a sealed hollow tube or chamber. It is attached to a primary cable/line, with length markings and an actuator rod (labeled Secondary Activation in Fig. 4) connected to a second line, which opens and closes the chamber's valves.

6.4.2 Procedure:

6.4.2.1 Measure and mark the support line or cable with the desired length or depth.

6.4.2.2 Close the chamber.

6.4.2.3 Lower the Bacon Bomb sampler using the primary support line or cable to the desired depth, as marked on the support line. Secure the line.

6.4.2.4 Open the chamber by pulling on the actuator rod line, thereby allowing the sampler to fill.

6.4.2.5 When the chamber is full, release the second line to close the sampler.

6.4.2.6 Return the sampler to the surface by raising the primary support line.

6.4.2.7 Transfer the contents of the Bacon Bomb sampler to a clean dry sample container. Hold the Bacon Bomb sampler over the sample container. Open the lower stopper by raising the actuator rod. Drain the contents into a clean sample container(s).

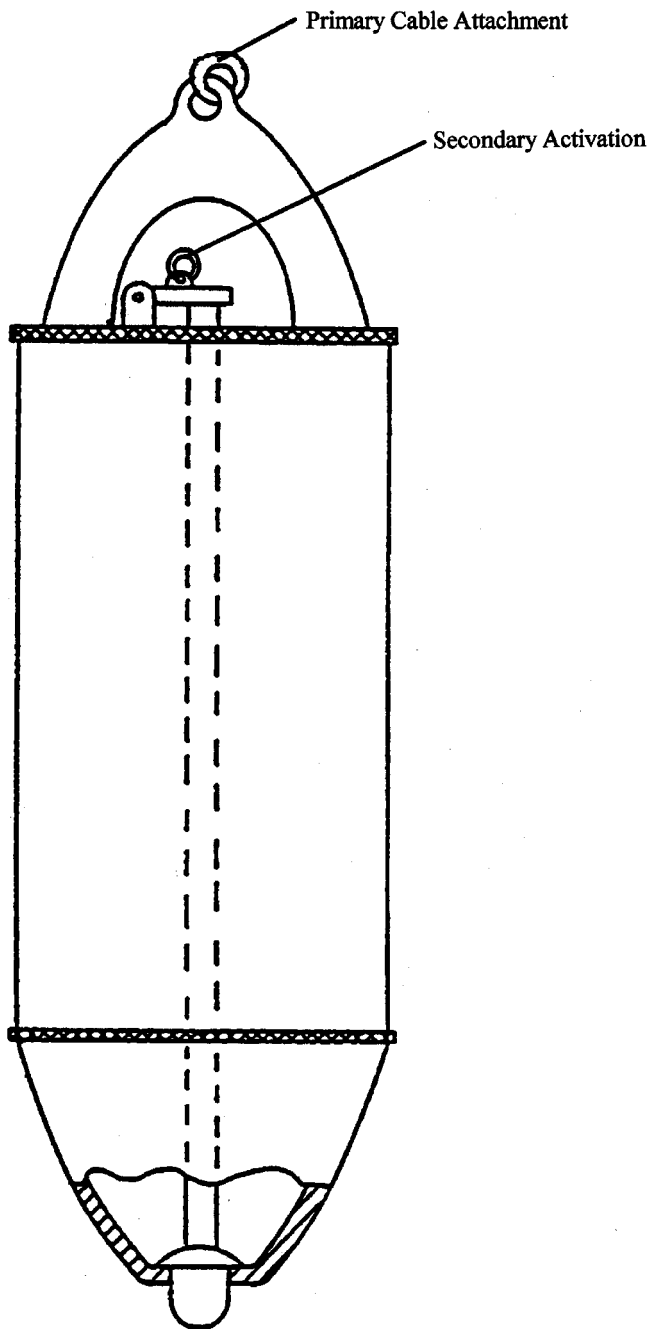

FIG. 4 Bacon Bomb

6.4.3 Advantages and Limitations:

Advantages
 Sampler is closed to the material being sampled until it has reached its intended depth, that is, it can be used as a discrete depth sampler.
 It is available in 250-, 500- and 1000-mL volumes in both PTFE and type 302 stainless steel.
 The stainless steel unit is effective for use in high viscosity non aqueous liquids, for example, oil.

Limitations
 The lowering and activation lines tend to cross each other during descent, which could allow sample collection to occur at the wrong depth.
 The commercially available stainless steel unit has a maximum capacity of 500 mL.
 PTFE device is expensive relative to stainless steel.
 Not effective in turbid sample media, according to the manufacturer.
 Slight leakage into the interior may occur with the stainless steel unit during descent, according to the manufacturer
 With viscous material, an excess of the material being sampled may adhere to the outside of the Bacon Bomb sampler.

6.5 Syringe Sampler:

6.5.1 *Description*—The Syringe sampler is a hollow tube type sampler with a bottom fill valve. A Syringe sampler normally consists of a piston assembly with a T-handle, safety locking nut, and control rod (PTFE-covered aluminum to facilitate operation of the piston), a piston body assembly, a sampling tube assembly, and a standard bottom valve or coring bottom (see Fig. 5).

6.5.2 *Procedure*:

- 6.5.2.1 Open the bottom valve.
- 6.5.2.2 Slowly lower the assembled sampler to the desired depth.
- 6.5.2.3 Raise the T-handle, drawing the sample into the sampler body.
- 6.5.2.4 Close the bottom valve by pressing the sampler down against the side or bottom of the container being sampled.
- 6.5.2.5 Raise the sampler to the surface using the support line.
- 6.5.2.6 Transfer the contents to a clean dry sample container. Hold the Syringe sampler over the sample container. Open the bottom valve and push down on the T-handle to extrude the sample into a clean sample container.

6.5.3 *Advantages and Limitations*:

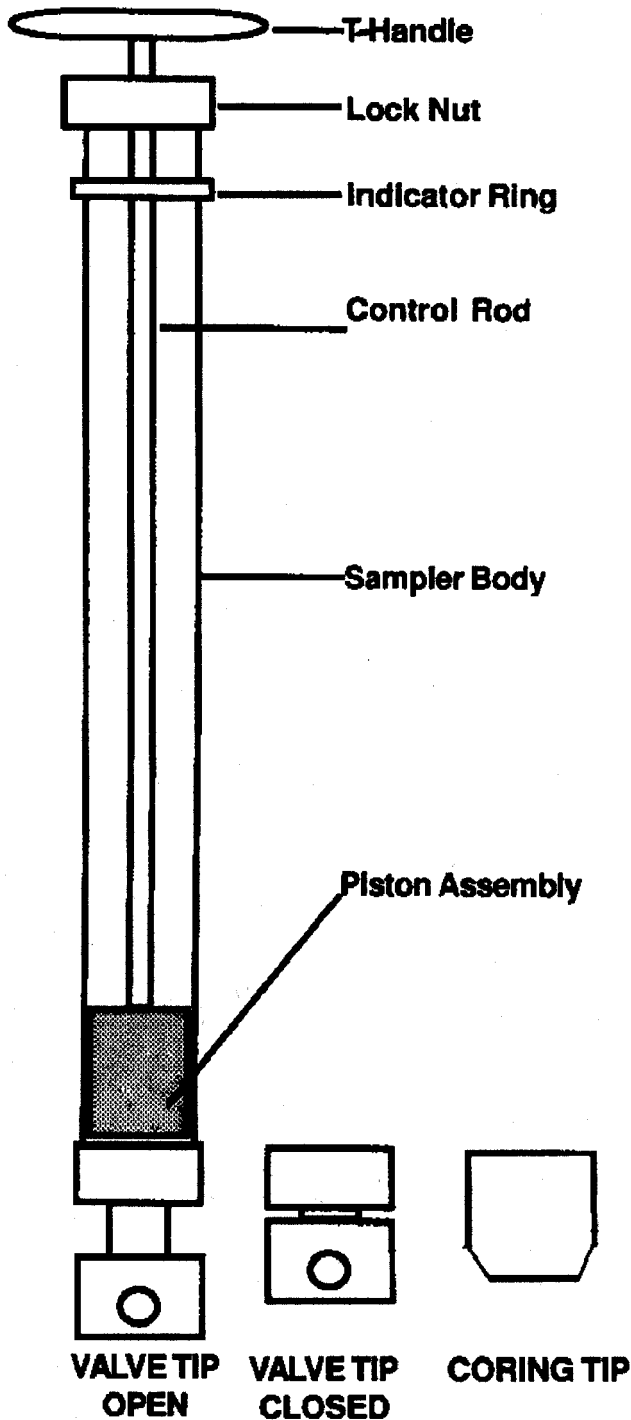

FIG. 5 Syringe Sampler

Advantages

It can be used to sample highly viscous liquids, sludges, and tar-like substances.
 It can collect samples even when only a small amount remains at the bottom of a tank or drum.
 All sample contacting parts are made of PTFE.
 It is simple to use and decontaminate.
 May be used to depths of about 1.8 m (6 ft).
 Sampler is closed to the material being sampled until it has reached its intended depth, that is, it can be used as a discrete depth sampler.

Limitations

The bottom of the syringe sample must be pushed against the bottom or side to close the bottom valve.
 With viscous material, more of the material being sampled may end up on the outside of the sampler than inside it

6.6 Kemmerer Sampler:

6.6.1 Description—The Kemmerer sampler consists of a cylinder with a stopper at each end. The ends of the cylinder are left open as the sampler is being lowered, in a vertical position, to allow free passage of liquid through the cylinder (see Fig. 6). The stoppers, usually rubber, are attached to a line or cable that runs through the cylinder. At the upper end of the line is a weight called a “messenger.”

6.6.2 Procedure:

- 6.6.2.1 Measure and mark the support line or cable with the desired length or depth.
- 6.6.2.2 Open the stoppers at both ends of the collection cylinder.
- 6.6.2.3 Place clamps on the top of the ring to prevent the stoppers from falling and sealing the cylinder prematurely.
- 6.6.2.4 Keep the Kemmerer in a vertical position and slowly lower it to the intended depth.
- 6.6.2.5 Send the “messenger” down the line to release the clamps and close the stoppers.
- 6.6.2.6 Raise the Kemmerer sampler to the surface.
- 6.6.2.7 Transfer the sample to a clean, dry sample container. Position the Kemmerer over the sample container, open the lower stopper, and drain the liquid into the clean sample container.

6.6.3 Advantages and Limitations:

Advantages

It can be used as a discrete depth sampler.
 It is available in stainless steel, brass or PTFE in volumes up to 2 L.
 There is little or no sample disturbance during sample collection.

Limitations

PTFE device is expensive relative to stainless steel.
 It may be difficult to decontaminate.
 If the line or cable that runs through the cylinder is a bungee type, it may become slack, which could cause a loss of sample.
 The device is open to the material being sampled.

6.7 Discrete Level Sampler:

6.7.1 Description—The Discrete Level sampler is a removable, cylindrical chamber fitted with manually operated

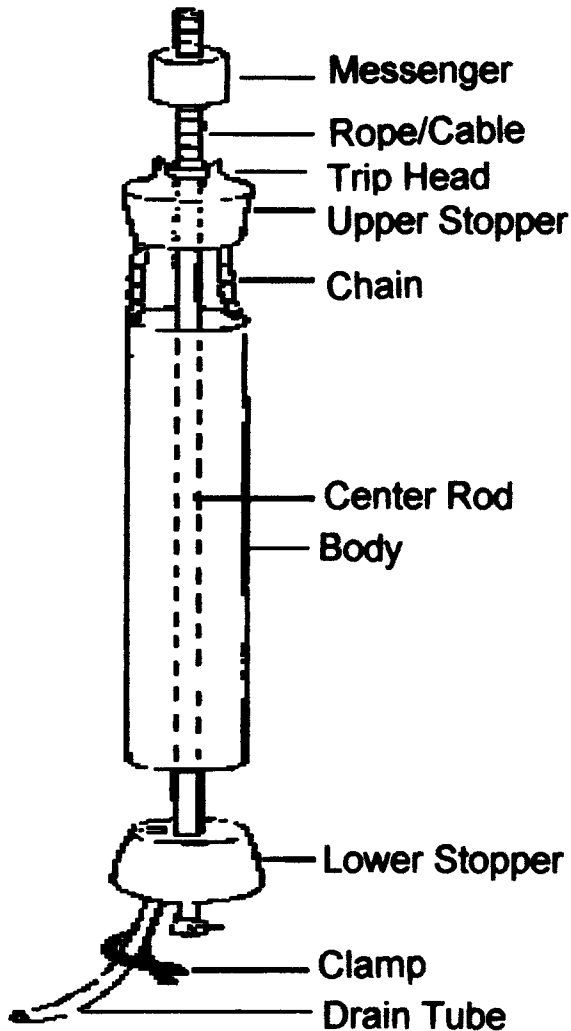

FIG. 6 Kemmerer Sampler

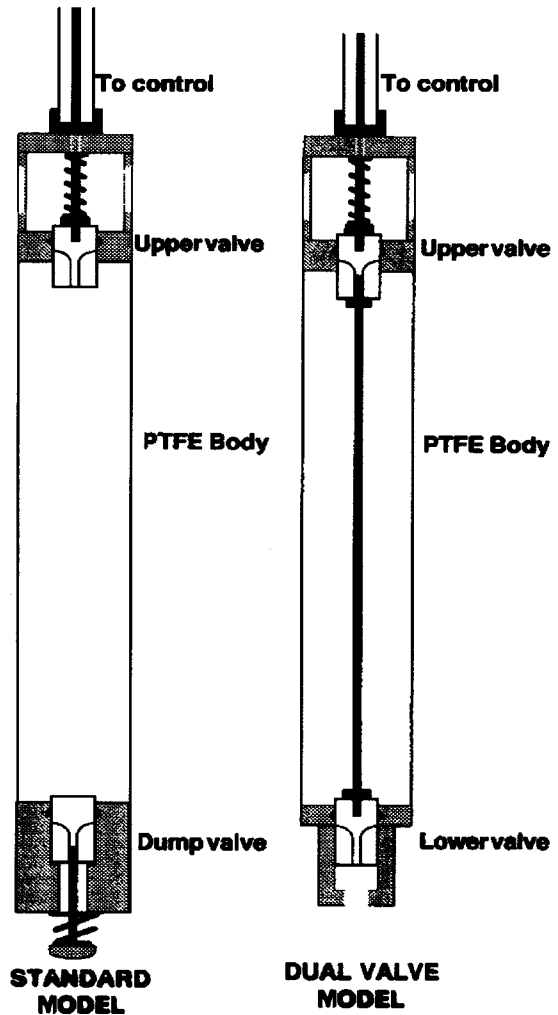

FIG. 7 Discrete Level Sampler

valve(s) on each end of the sample collection chamber (see Fig. 7). It is constructed of PTFE and stainless steel and is designed to be reusable. The Discrete Level sampler is assembled with either (1) a rigid control tube and rod or (2) a flexible tube and inner cable attached to the upper end of the sampler. The proximal ends of the controls are provided with a handle and inner rod or cable actuator.

6.7.1.1 The standard model is provided with an upper manually operated valve for filling and a lower spring-loaded "dump valve" for emptying. The dual valve model has manually operated valves at each end.

6.7.1.2 The cable and flexible tube model is suitable for depths up to 15 m (50 ft) below ground surface.

6.7.1.3 An electric solenoid operated model is suitable for depths to 300 m (1000 ft).

6.7.2 Procedure:

6.7.2.1 Measure and mark the support line or cable with the desired length or depth.

6.7.2.2 Close both valve(s).

6.7.2.3 Lower the sampler to the desired level in the liquid.

6.7.2.4 Open the upper valve (manually using the standard sampler and using the controls using the solenoid model) and open the lower valve using the controls, to collect the sample.

6.7.2.5 Close the valve.

6.7.2.6 Raise the sampler using the support line.

6.7.2.7 Transfer to the Laboratory:

(1) To transport the collected sample to the laboratory in the Discrete Level sampler body, replace the valves with solid PTFE end caps. Clean the outside surface. Label.

(2) To transport the collected sample to the laboratory in a separate sample container, hold the sampler over the clean sample container and empty the sampler's contents into the sample container. Empty the standard model sampler by pressing the dump (lower) valve against the inside of a sample container. Empty the dual valve model by opening the valves manually or with the use of a metering device attached to the lower end of the sampler (not shown).

6.7.3 Advantages and Limitations:

Advantages	Limitations
It may be used to sample liquids in most environmental situations.	Liquids containing a high percentage of solids may result in inadequately closed valves.
Sampler is closed to the material being sampled until it has reached its intended depth, that is, it can be used as a discrete depth sampler.	The sealed sample collection chamber may leak when being lowered to depth prior to opening for filling.
Remote operation is possible for hazardous environments.	The commercially available sample chamber capacities are 240-475 mL.
It is available in PTFE and stainless steel.	PTFE units are expensive relative to stainless steel.
The sampler cylinder may be used as the sample container.	If the sampler body is used to transport the sample, its exterior must be cleaned first.
The sampling tube is easy to decontaminate.	The valves are tricky to clean.
	With viscous material, more of the material being sampled may end up on the outside of the sampler than inside it.

6.8 Liquid Profiler:

6.8.1 Description—The liquid profiler consists of a clear poly(vinyl chloride) (PVC) tube, in one or more 1.5 m (5 ft) sections with internal diameters of 2.2 cm (1 in.) or 2.9 cm (1.3 in.), with a valve at the bottom. The internal diameter of the valve is usually 1.6 cm (0.7 in.). The top section is attached to a nylon line for lowering and raising the sampler (see Fig. 8).

6.8.2 Procedure:

6.8.2.1 Measure and mark the support line or cable with the desired length or depth.

6.8.2.2 Lower the liquid profiler slowly so that the level of the liquid being sampled is the same on the inside and outside of the profiler. The bottom check valve opens as the liquid profiler is lowered.

6.8.2.3 When the bottom of the tank is reached, stop.

6.8.2.4 Raise the unit and tug slightly on the rope. This sets the check valve, collecting the column of liquid and suspended solids in the profiler.

6.8.2.5 When the unit has been raised clear of the liquid, read the amount of solids in the sample by using the 1-ft increment marked on the pipe sections.

6.8.2.6 To release the sample from the profiler:

- (1) Place the profiler over the clean, dry sample container.
- (2) Touch the pin extending from the bottom section against a hard surface. This opens the check valve to drain the sample.

NOTE 2—For a representative sample of the column of liquid, discharge the entire sample into one container. If multiple samples are desired, the sample should be mixed and subsampled.

6.8.3 Advantages and Limitations:

Advantages	Limitations
This sampling device is used to sample liquid columns at a discrete depth.	It requires a special size cleaning brush, with a handle at least 1.5 m (5 ft) long, for decontamination.
The 1-ft markings on the tubing help to identify the depth of liquid in the tank and the amount of sludge, if any, on the bottom.	When extending the unit longer than 4.6 m (15 ft), a stiffener may be needed to reduce excessive bending.
Sections of 1.5 m (5 ft) can be added or removed as required.	The commercially available construction materials (PVC) may not be compatible with the parameters of concern.
This sampling device collects a depth-integrated sample.	

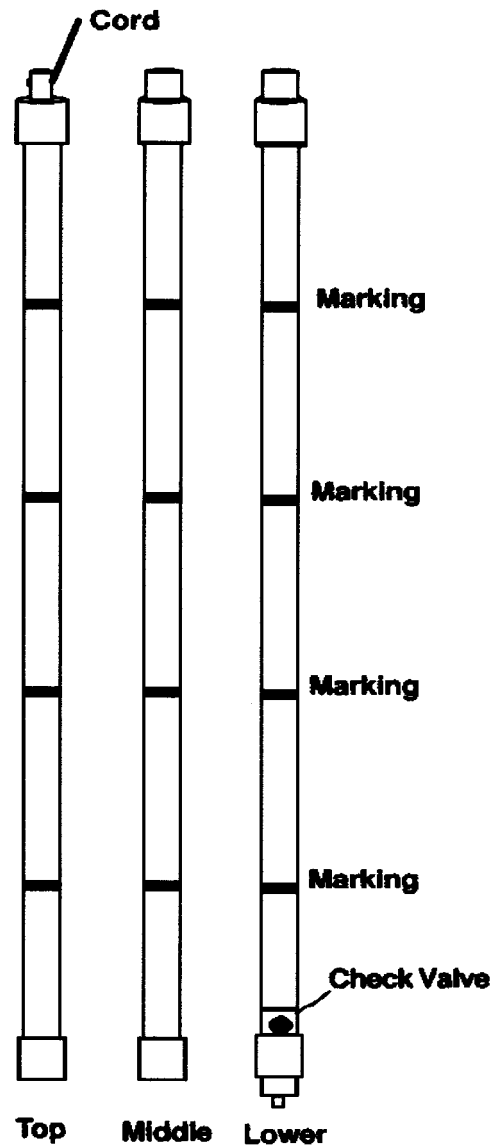

FIG. 8 Liquid Profiler

6.9 Lidded Sludge/Water Sampler:

6.9.1 Description—The lidded sludge/water sampler is a stainless steel sampling apparatus holding a 1-L glass jar. It consists of a jar with a lid, secured to the frame with a long T-handle. For samples containing more than 40 % solids, a cutter can be added to the jar to cut the sludge, allowing it to fall into the jar. Handle extensions with depth markings are available to allow sampling from difficult to access areas (see Fig. 9).

6.9.2 Procedure:

- 6.9.2.1 Close the 1-L glass jar.
- 6.9.2.2 Lower the lidded sludge/water sampler into the liquid or sludge to the desired depth.
- 6.9.2.3 Rotate the top actuator handle counter-clockwise open the jar and to orient the jar to an upright position.
- 6.9.2.4 Rotate the top actuator handle clockwise to close the lid.
- 6.9.2.5 Raise the sampler to the surface.
- 6.9.2.6 Remove the jar from the holder.

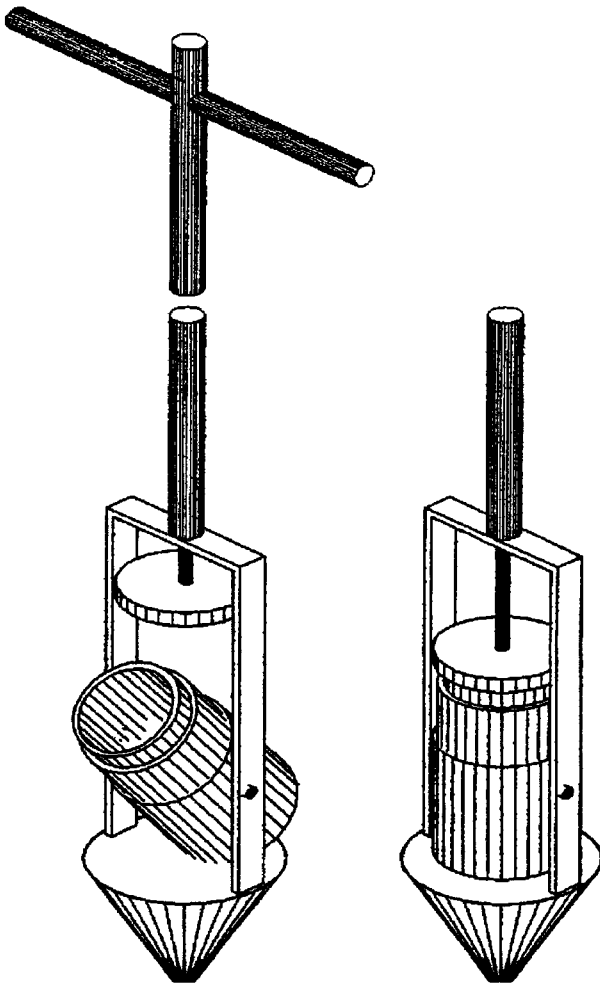

FIG. 9 Lidded Sludge/Water Sampler

6.9.2.7 Clean the exterior of the jar.

6.9.2.8 Label the jar and transport the jar to the laboratory for analysis. No transfer of the sample to another container is necessary.

6.9.3 *Advantages and Limitations:*

Advantages	Limitations
<p>The collection bottles and lids are also the sample containers, which reduces potential sample contamination.</p> <p>Container is closed to the material being sampled until it has reached its intended depth, allowing collection of samples from discrete depths.</p> <p>Bottles and lids are unique to each sample; decontamination is not required.</p>	<p>Device is relatively expensive for sampling water because of the materials of construction.</p> <p>The sampling exposes the outside of the sample container to the media being sampled. Exterior of jar, now sample bottle, must be cleaned prior to shipment.</p> <p>Equipment is heavy, limiting its use to depths of ~30 ft.</p> <p>Sample is limited to one bottle size.</p>

6.10 *Peristaltic Pump (Suction Transfer Through Tubing):*

6.10.1 *Description*—A peristaltic pump is a nonsubmersible, suction lift pump that is used at the ground surface. It is also well suited for sampling from the edge of a body of water, a platform, or a bridge.

6.10.1.1 A length of PTFE or other suitable tubing is placed in the liquid to be sampled and the other end is connected to the piece of flexible tubing that has been threaded around the rotor

of the peristaltic pump. A second piece of PTFE or other suitable tubing is connected to the discharge end of the pump flexible tubing to allow the water to be containerized, sampled, etc. (see Fig. 10). If the flexible tubing is not compatible with the sample parameters of concern, a modification to the system is necessary.

6.10.1.2 The modification (see Fig. 10) consists of a peristaltic pump using PTFE tubing and a PTFE insert to collect samples without the sample coming into contact with the flexible tubing. The PTFE insert is placed into the opening of a clean container. The PTFE tubing connects the container to the pump and sample source. As the peristaltic pump rotor compresses the flexible tubing, causing a vacuum in the inlet tubing, the liquid is drawn up the inlet tubing and into the container without coming into contact with the pump tubing.

6.10.1.3 Information on flexible tubing materials for the pump can be found in Guide D 6538, paragraph 9.4.1 and the accompanying references.

6.10.2 *Procedure:*

6.10.2.1 Measure and mark the inlet tubing with the desired length or depth.

6.10.2.2 Place the weighted end of the inlet tubing into the liquid to the desired depth.

NOTE 3—If sampling from a stream, the tubing inlet should be facing upstream.

6.10.2.3 Place the end of the outlet tubing into the clean dry sample collection container.

6.10.2.4 Turn on the pump and collect the sample into the container.

6.10.2.5 Turn off the pump and label the sample.

6.10.3 *Optional Procedure for Samples for Purgeable Organic Compounds:*

6.10.3.1 To reduce potential loss of VOCs:

6.10.3.2 Measure and mark the inlet tubing with the desired length or depth.

6.10.3.3 Place the weighted end of the inlet tubing into the liquid to the desired depth.

NOTE 4—If sampling from a stream, the tubing inlet should be facing upstream.

6.10.3.4 Turn on the pump until the tubing is full of the liquid being sampled.

6.10.3.5 Turn off the pump.

6.10.3.6 Carefully withdraw the tubing from the liquid and place the non-weighted end in a clean, dry sample container.

6.10.3.7 Disconnect the tubing.

6.10.3.8 Allow the tube to drain into the sample container(s).

NOTE 5—When the suction is high, for example, when the pump lifts the sample well above the water surface, the concentration of VOCs in the sample is unlikely to be representative of their concentrations in the material being sampled.

6.10.4 *Optional Procedure for Collection of a Depth Integrated Sample:*

6.10.4.1 The peristaltic pump can also be used to collect a depth integrated sample by lowering the weighted intake at a constant rate until near the bottom, turning the pump

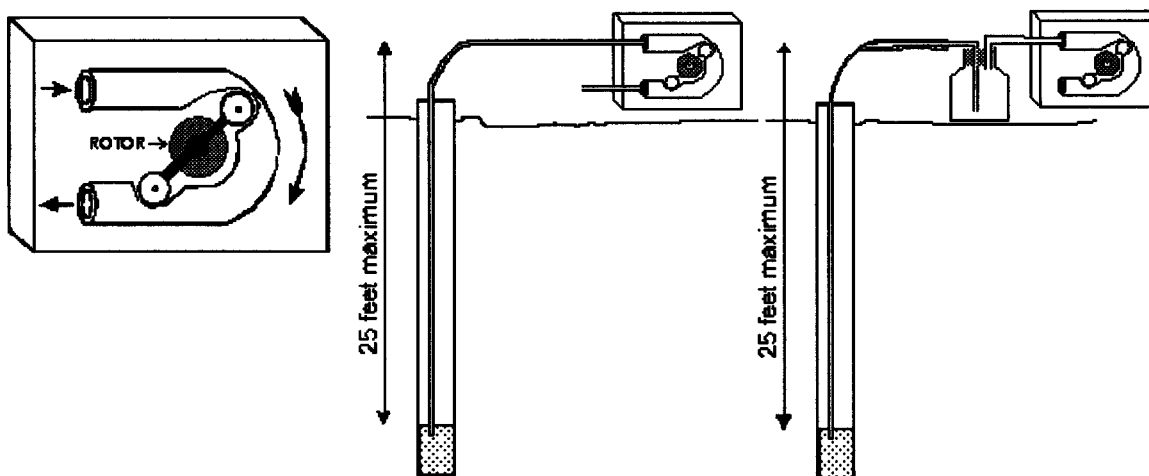

FIG. 10 Peristaltic Pump (Suction Transfer Through Tubing)

off, retrieving the weighted end, and pumping the liquid remaining in the intake tubing into the sample container.

6.10.5 Advantages and Limitations:

Advantages
 It is possible to collect samples from multiple depths without removing the inlet tube from the material being sampled, that is, it can be used as a discrete depth sampler. Decontamination of the pump motor is not necessary. It is easy to replace the tubing in the pump. May be used in very small diameter (2 cm) openings.

Limitations
 The pump cannot lift a sample more than about 7.6 m (25 ft) above the surface of the liquid being sampled. Volatile compounds may be lost. Viscous liquids may necessitate different size tubing or motor head, or both. For certain sampling situations, it may be necessary to attach a screen on the inlet end of the tube to prevent clogging with solids. The tubing is exposed to the liquid as it is lowered and needs to be flushed prior to sample collection. Special pump tubing or a special sampling technique required to prevent contamination of VOC sample with plasticizers from the tubing. (See Guide D 6538.)

7. Post-Sampling

7.1 At a minimum, upon completion of the sampling, the following should be completed.

7.1.1 Decontaminate the equipment (Practice D 5088 and Guide D 4687, Section 9). Some samplers may be difficult to decontaminate due to construction design.

7.1.2 Document the sampling event. Recommendations for information to be included in a logbook and on labelling samples are described in Guide D 4687, Section 10.

7.1.3 If the sample is to be submitted to any laboratory for analysis, complete the appropriate chain-of-custody documentation. See the information described in Guides D 4840 and D 4687.

8. Keywords

8.1 discrete depth sampling; grab sampling; liquid; sampling; sampling equipment; waste management

APPENDIX

(Nonmandatory Information)

X1. GENERAL INFORMATION FOR GRAB AND DISCRETE SAMPLERS

X1.1 General Attributes

X1.1.1 The following list of attributes is not necessarily comprehensive but should be considered a basis for an appropriate sampling device or sampler. The sampling equipment needs to be or have:

- X1.1.1.1 Suitable for sampling through the opening at the top of a stationary container.
- X1.1.1.2 Capable of collecting a sample volume sufficient for the analytical needs, usually between 40 mL and 1 L.
- X1.1.1.3 Easy to decontaminate.
- X1.1.1.4 Able to retain liquids and easy to open and close.

- X1.1.1.5 Strong, yet easily cleaned support lines, if needed.
- X1.1.1.6 Constructed of inert materials to preclude contamination of the population or the sample.
- X1.1.1.7 Easy to maintain and repair in the field.
- X1.1.1.8 A way to minimize contact of the sample with the air, if volatiles are to be analyzed.

X1.2 General Considerations

X1.2.1 The depth at which the sample is collected needs to be measured and documented to ensure conformance with predetermined project objectives. Most sampling devices are

lowered by means of a primary support line, marked at regular intervals for ease of measuring the level at which the sample is collected.

X1.2.2 The sampling device should be lowered slowly to prevent disruption of any layering or stratification. A common error is lowering the device too quickly, resulting in a sample that is not representative of the intended depth.

X1.2.3 Depending on the sampling device, the presence of plant or animal life may interfere with obtaining a representative sample.

X1.2.4 The sampling location for stationary containers, for example, tanks, will depend on the available container opening. For open bodies of water, the location(s) may be specified in a permit, determined by the location of an inlet area, or established by a grid and sightings from shore, or a combination thereof. Surveying may be necessary.

X1.2.5 Some mixing of the liquid will occur as it is being sampled.

X1.2.6 There is a volume of material at the bottom of any tank, drum, pond, and so forth, which will be inaccessible. This volume will be considered in the sampling plan and incorporated in the overall sampling and analysis error.

X1.2.7 Care should be taken to avoid disrupting the bottom sediment, which may bias the sample.

X1.2.8 If at all possible, hazardous sampling locations should be avoided, especially those requiring respiratory protection or confined space entry, where at a minimum, a confined space entry permit is required.

X1.2.9 When collecting samples from multiple depths at the same location, samples should be collected from shallowest to deepest depths and care should be used to avoid disturbing sediments.

ASTM International takes no position respecting the validity of any patent rights asserted in connection with any item mentioned in this standard. Users of this standard are expressly advised that determination of the validity of any such patent rights, and the risk of infringement of such rights, are entirely their own responsibility.

This standard is subject to revision at any time by the responsible technical committee and must be reviewed every five years and if not revised, either reapproved or withdrawn. Your comments are invited either for revision of this standard or for additional standards and should be addressed to ASTM International Headquarters. Your comments will receive careful consideration at a meeting of the responsible technical committee, which you may attend. If you feel that your comments have not received a fair hearing you should make your views known to the ASTM Committee on Standards, at the address shown below.

This standard is copyrighted by ASTM International, 100 Barr Harbor Drive, PO Box C700, West Conshohocken, PA 19428-2959, United States. Individual reprints (single or multiple copies) of this standard may be obtained by contacting ASTM at the above address or at 610-832-9585 (phone), 610-832-9555 (fax), or service@astm.org (e-mail); or through the ASTM website (www.astm.org).