



Designation: E 981 – 84 (Reapproved 1996)<sup>ε1</sup>

## Standard Test Method for Estimating Sensory Irritancy of Airborne Chemicals<sup>1</sup>

This standard is issued under the fixed designation E 981; the number immediately following the designation indicates the year of original adoption or, in the case of revision, the year of last revision. A number in parentheses indicates the year of last reapproval. A superscript epsilon (ε) indicates an editorial change since the last revision or reapproval.

<sup>ε1</sup> NOTE—Section 17 was added editorially in October 1996.

### 1. Scope

1.1 This laboratory test method provides a rapid means of determining sensory irritant potential of airborne chemicals or mixtures. It may also be used to estimate threshold limit values (TLV) for man. However, it cannot be used to evaluate the relative obnoxiousness of odors.

1.2 This test method is intended as a supplement to, not a replacement for, chronic inhalation studies used to establish allowable human tolerance levels.

1.3 *This standard does not purport to address all of the safety concerns, if any, associated with its use. It is the responsibility of the user of this standard to establish appropriate safety and health practices and determine the applicability of regulatory limitations prior to use.* Specific hazard information is given in Section 6.

### 2. Summary of Test Method

2.1 This test method quantitatively measures irritancy as indicated by the reflex inhibition of respiration in mice exposed to sensory irritants.

2.2 Four mice are simultaneously exposed to the airborne chemical. Usually a sufficient number of groups of animals are exposed to a geometric series of concentrations so that a concentration-response curve can be constructed. For simple preliminary comparisons, however, a single group of four animals at one concentration will suffice.

2.3 The mice are placed in a body plethysmograph attached to an exposure chamber so that only the head is exposed to the test material. The plethysmographs are connected to pressure transducers, which sense changes created by inspiration and expiration. The amplified signals are transmitted to a polygraph recorder.

2.4 The concentration of airborne irritant that produces a 50 % decrease in respiratory rate (RD50) is determined from the concentration-response curve constructed from the various data points obtained with a series of concentrations.

### 3. Significance and Use

3.1 This test method was developed to meet the following criteria:

3.1.1 It provides positive recognition of sensory irritants of widely varying potencies.

3.1.2 It is sufficiently simple to permit the testing of large numbers of materials.

3.1.3 This test method is capable of generating concentration-response curves for purposes of compound comparison.

3.1.4 This test method has good reproducibility.

3.2 This test method can be used for a variety of divergent purposes, including the assessment of comparative irritancy of compounds or formulations and setting interim exposure levels for the workplace (**1, 2**).<sup>2</sup>

3.3 It has been shown that for a wide variety of chemicals and mixtures, a perfect rank order correlation exists between the decreases in respiratory rate in mice and subjective reports of sensory irritation in man (**1, 3, 4, 5**).

3.4 A quantitative estimate of the sensory irritancy of a wide variety of materials can be obtained from concentration-response curves developed using this method (**1, 3, 4, 6, 7, 8**).

3.5 Although this test method is intended to measure sensory irritation of the nasal mucosa, the cornea is innervated by the same nerve. This animal model will, therefore, allow an estimate of the irritant potential of cosmetic ingredients or other household products to the eye, assuming that they can be aerosolized (**9**).

3.6 This test method is recommended for setting interim guidelines for exposure of humans to chemicals in the workplace, to assess acute sensory irritation resulting from inadvertent spills of household products, and to assess the comparative irritancy of formulations or materials intended for a variety of uses.

3.7 This test method will detect irritating effects at concentrations far below those at which pathological changes are observed.

NOTE 1—A good overview of the toxicological evaluation of irritant compounds is given in Ref (**8**).

### 4. Apparatus

4.1 The apparatus required to perform this test is listed below. The basic components for testing any type of material

<sup>1</sup> This test method is under the jurisdiction of ASTM Committee E-35 on Pesticides and is the direct responsibility of Subcommittee E35.26 on Safety to Man. Current edition approved Feb. 24, 1984. Published May 1984.

<sup>2</sup> The boldface numbers in parentheses refer to the list of references at the end of this standard.

are the same. A list of suitable apparatus and suppliers is found in Appendix X1.

4.2 *Plethysmograph Tubes.*

4.3 *Exposure Chamber*, constructed entirely of glass, with a volume of 2.3 L.

4.4 *S.T.103/60 Ground Glass Joint*, that allows access to the inside of the exposure chamber.

4.5 *Perforated Rubber Dental Dam*, reinforced with electrical tape.

4.6 *Rubber Stoppers.*

4.7 *"T" Tube*, with a tube 6 cm long and the "T" 12 cm long.

4.8 *Vacuum Pump.*

4.9 *Flowmeter.*

4.10 *Absolute Filter.*

4.11 *Sodium Carbonate-Activated Charcoal Filter.*

4.12 *Pressure Transducer.*

4.13 *Polygraph Recorders.*

4.14 *Frequency-to-Voltage Converter*, operating in the averaging mode instead of the pulse mode. See Appendix X1.7.

4.15 *Voltage Addition and Division Equipment*, to obtain the signal average for four mice.

4.16 *Signal Averages.*

4.17 *Oscillograph.*

4.18 *Aerosol Generator.*

4.19 *Timer.*

4.20 *Control Valve.*

## 5. Reagents

5.1 Technical reagents may be used in all tests where solvents other than water are required.

5.2 Solutions containing 1 to 3 % of the test material are used for comparative studies.

## 6. Hazards

6.1 Not all compounds that cause a decrease in respiratory rate are sensory irritants. To be characterized as a sensory

irritant, a compound must produce a net decrease in respiratory rate as a result of the characteristic pause during expiration as shown in Fig. 1. This pause differentiates sensory irritants from pulmonary irritants, general anesthetics, and asphyxiants, which also reduce respiratory rate, but as a result of a pause between breaths as shown in Fig. 2.

6.2 It is possible for one component to alter the effect of another in a mixture, depending on their respective concentrations (10). Additive and antagonistic responses are possible. For this reason the effects of each compound in a formulation should be assessed before any test is made for interactions.

6.3 Although the test procedure has been found to show a high correlation for sensory irritants with established TLV values for man, it may well predict values that are too high for compounds of low reactivity that are metabolically activated, and also for pulmonary irritants (9).

## 7. Test Animals

7.1 Mice are the subjects to be used for this test. It is imperative that they meet the specifications outlined here. Although any mouse of the proper size could be used, marked differences have been observed between different strains and sexes (2).

7.1.1 Male Swiss-Webster mice shall be used as the test subjects.

7.1.2 Only animals weighing between 22 and 28 g may be used. Smaller mice might be able to crawl into the exposure chamber, while larger ones may not be able to breathe normally in the apparatus.

## 8. Preparation of Apparatus

8.1 *Exposure Chamber:*

8.1.1 The heads of each of four mice extend into the exposure chamber, and the bodies are contained in plethysmograph tubes. Perforated rubber dental dam reinforced with electrical tape provides tight but comfortable seals around the

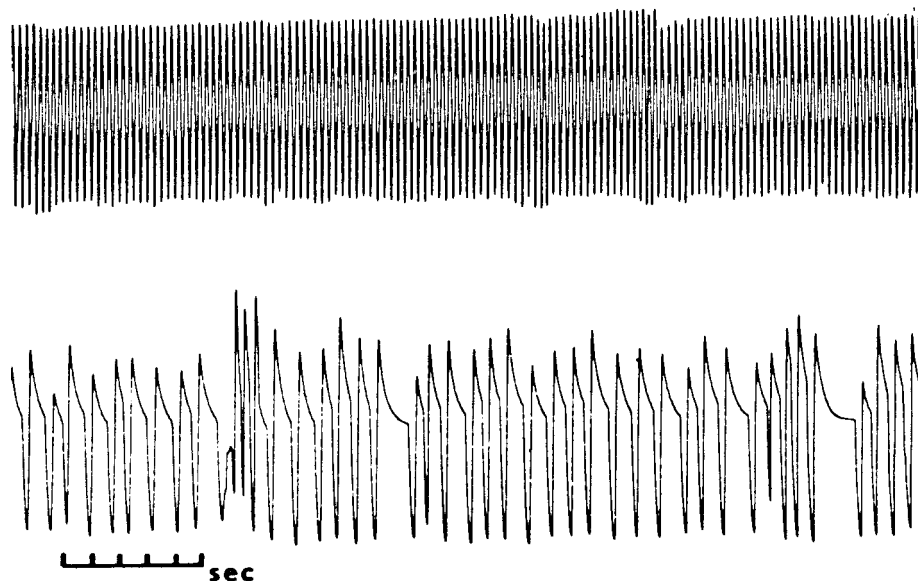

NOTE 1—Taken from Ref. (3).

FIG. 1 Typical Tracing of Normal Mouse Respiration (Top), and of a "Moderate" Sensory Irritant Response (Bottom)

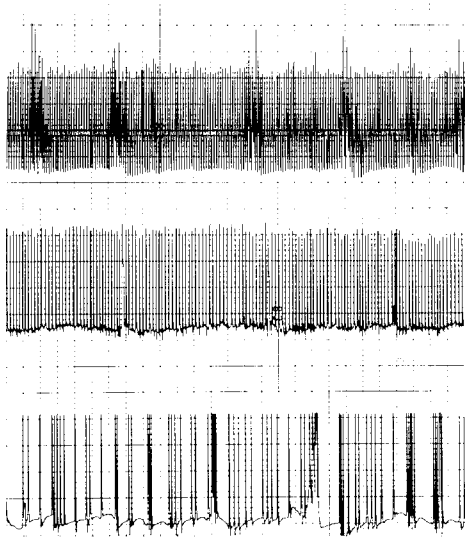

NOTE 1—Taken from Ref. (8).

**FIG. 2 Typical Tracing of Normal Mouse Respiration (Top), a Moderate Pulmonary Irritant Response (Center), and an Extreme Pulmonary Irritant Response (Bottom)**

animals' necks, and rubber stoppers prevent them from backing out of the tubes, and provides an airtight body plethysmograph (see Fig. 3).

8.1.1.1 The "T" tube is of the same diameter as the inlet to the chamber. The gas or aerosol from the generator enters one side of the "T" and the makeup air enters on the other. Thus the tube acts as a miniature mixing chamber, eliminating the need for a baffle plate. The "T" tube is not shown in Fig. 3.

8.1.2 Chamber Equilibration:

8.1.2.1 It is desirable to reach equilibrium of the test material in the exposure chamber in as short a time as possible. In no case should this time exceed one-tenth of the total

exposure time. The validity of the data for extrapolation to man requires rapid attainment of maximum concentration.

8.1.2.2 Equilibration time in minutes is 5.0 times the chamber volume in litres divided by airflow through the chamber in litres per minute (11).

8.2 A vacuum pump with a control valve monitored by a flowmeter provides a constant airflow through the exposure chamber. Chamber effluent is passed through an absolute filter and then a sodium carbonate-activated charcoal filter before exhausting, preferably into a fume hood. (See Fig. 4.)

8.3 Each of the four plethysmograph tubes is connected to a pressure transducer. As the mouse inhales, a positive pressure is created and exhalation results in a negative pressure. The amplified signals are recorded on a polygraph, which has the polarity set so that an upward deflection is obtained during inspiration and a downward deflection is obtained during expiration. The signal from each transducer is also fed into a frequency-to-voltage converter, and then fed into a signal averager. The output of the averager is displayed on a second recorder, thus permitting continuous monitoring of the average respiratory rate of the four mice. (See Fig. 4.)

8.4 A suitable generator for this test is a glass Dautrebande-type generator modified to allow continuous feed of test material.<sup>3</sup> This generator can be used for volatile or nonvolatile liquids, solutions, or suspensions of solids. It is depicted schematically in Fig. 5.

8.4.1 For aqueous solutions, liquid is delivered via a pump regulated at 1.0 mL/min to the right-hand tube. This delivery rate can be varied by a factor of 3 to 4. Air is delivered at 10 to 12 psig when a water solution is used, and 8 to 10 psig when acetone solution is used. With acetone the amount of solution delivered is restricted so that no more than 3000 ppm acetone

<sup>3</sup> Pitt No. 1 aerosol generator available from Scientific Glassblowing Laboratory, McKees Rocks, PA 15136, has been found suitable.

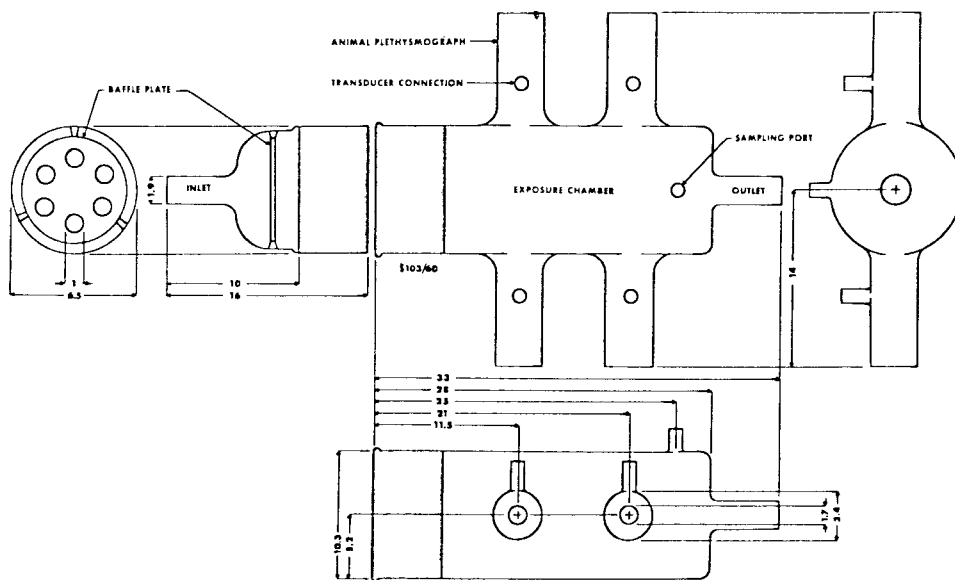

NOTE 1—Dimensions are in centimetres.

NOTE 2—Taken from Ref. (18).

**FIG. 3 Glass Exposure Chamber with Attached Body Plethysmographs**

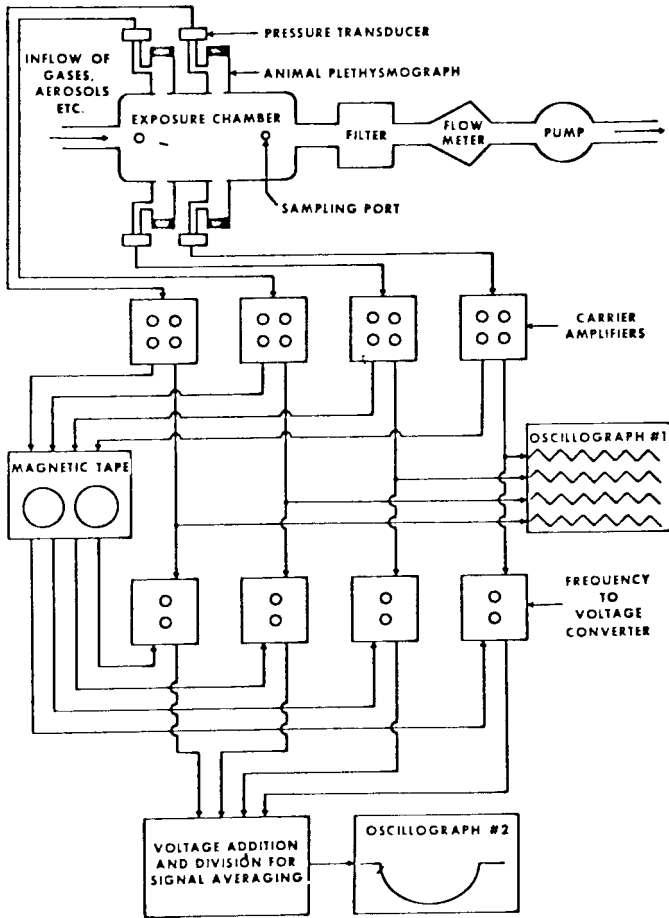

NOTE 1—Taken from Ref. (18).  
**FIG. 4 Diagram of Test Apparatus**

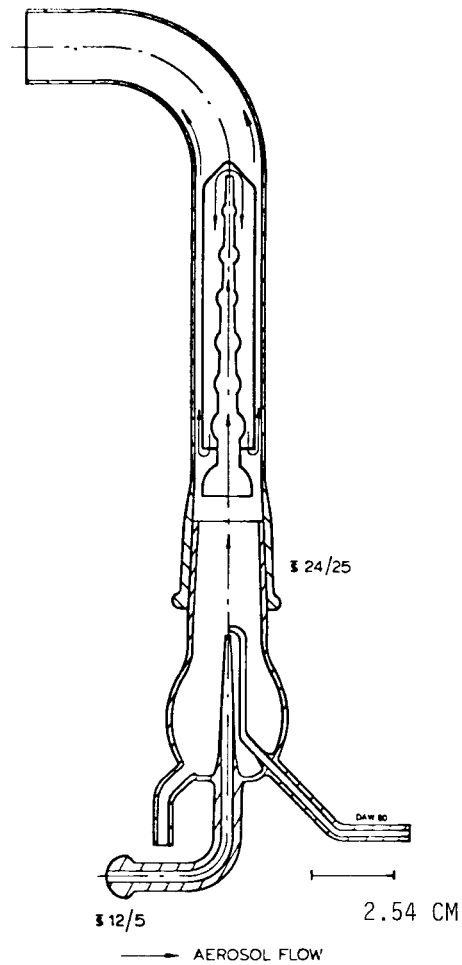

NOTE 1—Taken from Ref. (11).  
**FIG. 5 Schematic Representation of the Pitt No. 1 Aerosol Generator**

vapor is produced in the exposure chamber. The calculation is made from the total airflow used in the chamber. At the standard flow rate of 20 L/min through the chamber, delivery to the generator of 0.22 mL of acetone per minute will result in a concentration of 2800 to 3000 ppm. With acetone there will be no liquid overflow, but with aqueous solutions, 1.0 mL/min is high enough so that liquid will fall to the bottom of the generator. This is collected in a reservoir via the overflow tube.

8.4.2 Arrows in Fig. 5 indicate the path that the aerosol will follow. Polyethylene Glycol 200 (PEG 200) can be used as a solvent instead of water. The air pressure should be about 20 to 25 psig with this solvent. Dry air must be used with PEG 200, which is hygroscopic. Using this generator with a 1 % solution of test material in water and 20 L/min flow rate through the exposure chamber, the concentration in the chamber will be between 10 to 20 mg/m<sup>3</sup> and most particles will be submicronic.

8.4.3 The Dautrebande-type generator can also be used to vaporize liquids for exposure of animals to vapors. For this purpose, the liquid is delivered at a known rate by a regulated pump and airflow is set at 10 to 20 psig. For liquids of lower vapor pressure, heating tape can be used around the generator to increase vaporization efficiency. For aerosols or vapors likely to oxidize rapidly in air, dry nitrogen should be used instead of air. When this is done, pure oxygen is added to the

chamber airflow to maintain 18 to 20 % O<sub>2</sub> in the exposure chamber. When suspensions are to be tested, the suspended material must be very fine to prevent clogging of the tip on the generator. Although larger tips can be used if required, a degradation of aerosolizing performance will result from their use.

8.5 To start and stop test material generation, a timer and an associated control valve are needed in conjunction with the aerosol generator.

8.6 When using water or acetone a “dry” particle will be produced, since both solvents will evaporate. However, PEG 200 will not evaporate and a liquid droplet is obtained. Mass concentration in the chamber should be obtained by sampling on filters and weighing on an appropriate balance. A better method, but one not required in a screening experiment, is appropriate chemical analysis. When acetone is used, its concentration in the chamber should be verified. Indicator tube analysis is adequate, or an infrared analyzer or gas chromatographic analysis can be used.

8.7 Gases are delivered directly into the exposure chamber via an appropriate flowmeter.

8.8 With the exception of the exposure chamber which is essentially a unique piece of apparatus, other parts can be

substituted by similar equipment. Also, minicomputers can be used to replace the frequency-to-voltage converter and signal-averaging device. The magnetic tape is not required, and a four-trace oscilloscope with storage capability can replace oscillograph No. 1.

## 9. Sample Preparation

9.1 Because of the large variety of chemicals and formulations that can be tested by this procedure, and the tremendous differences in irritant potential between them, no specific stipulation for sample preparation can be made. The only requirement for concentration is that the levels to be tested are spaced at even logarithmic intervals to allow good concentration-response curves to be generated from the data obtained. The information provided in the succeeding paragraphs of this section is therefore intended for general guidance only.

9.2 For solids and nonvolatile liquids, solutions are prepared in an appropriate solvent. Water and polyethylene glycol 200 (PEG 200) are the most commonly used for this purpose, although 0.1 *N* HCl, 0.1 *N* NaOH, and acetone can also be used. In the case of acetone, which is a mild irritant, the concentration in the chamber should be kept below 3000 ppm to avoid irritation from the solvent.

9.3 As an indication of concentrations to be expected, 1 % aqueous basic, or acidic solutions produce concentrations of 10 to 20 mg/m<sup>3</sup> at an airflow of 20 L/min in the exposure chamber. Polyethylene glycol 200 solutions will produce a concentration of 40 to 50 mg/m<sup>3</sup> of the solute under similar circumstances.

9.4 Gases shall be mixed with room air to produce the desired concentrations.

## 10. Calibration

10.1 In this test method, three parts of the equipment require calibration. Once these calibrations have been made, recalibration is not necessary for the conditions previously used unless the apparatus is disassembled.

10.2 *Generator*—Determine the particle size of the aerosol droplets emitted by each generator for each type of solution or suspension to assure the validity of the tests. A 1 % aqueous solution under 10 to 12 psig will produce particles of aerodynamic equivalent diameter of 0.6 to 0.8 μm, with a geometric standard deviation of 2.0 to 2.5. With PEG 200 at a pressure of 20 to 25 psig, the particle size will be 1.0 to 2.0 μm, with a similar geometric deviation. Particle size analysis may be made using an Anderson mini-impactor or other appropriate technique.

10.2.1 To assure that a generator is performing correctly, test solutions of 1 % NaCl in water and of undiluted PEG 200 should be tested. Start the generator at the pressure recommended for the particular solvent, and shine a light beam across the generator outlet. A constant flow of particles must be visible. Water without solute will evaporate too quickly to be observed, and therefore should not be used for this test.

10.3 *Plethysmograph*—The plethysmograph chambers require minimal calibration to assure equivalence of response from all four chambers. All that is required is that a signal of sufficient amplitude be displayed on the recording polygraph to discern the respiratory pattern of each animal. The amplitude

should be about the same for each animal, but this is not critical.

10.4 *Flowmeter*—The flowmeter must be calibrated so that desired flow rates are uniformly maintained. These rates are easily determined for various readings on the flowmeter, and will remain constant as long as the air supply is constant. Oil-washed air from a compressed gas cylinder in conjunction with a calibrated gage from a reputable manufacturer should be used as a source of air for the generators.

## 11. Pretest Conditioning

11.1 It is essential that healthy animals are used for this test. In order to assure that this is so, it is necessary to hold and to observe them for 7 days prior to use.

11.2 The mice may be gang-housed if desired.

11.2.1 Thoroughly clean and sanitize the cages prior to use, and provide ground corncob or similar bedding.

11.3 Individually identify each animal.

11.4 Take weights of the mice at the time the mice are caged, and again just prior to the test to assure reasonable weight gain. It is also advisable to note food consumption as an additional check on animal health.

11.5 Maintain the laboratory animal housing environment according to acceptable animal care accreditation requirements (12). Significant deviations therefrom must be noted and reported.

## 12. Selection of Test Parameters

12.1 For the purpose of comparing a variety of sensory irritants, the test parameters listed below have been found desirable:

12.1.1 Male, Swiss Webster mice weighing between 22 and 28 g shall be used as test subjects.

12.1.2 A ten-minute acclimation period, in which the mice are in the plethysmograph tubes, but breathing room air, is to be used.

12.1.3 Standard airflow rate through the exposure chamber shall be 20 L/min.

12.1.4 Test compound shall be generated at a level of 100 mg/m<sup>3</sup> of air.

12.1.5 Exposure time shall be 30 min. This lengthy exposure time has been found necessary to detect slow-acting irritants such as isocyanates, particularly at low concentrations (13).

12.1.6 A 10-minute recovery period shall be recorded after the aerosol exposure is completed.

12.2 Almost any desired change can be made in these parameters to serve a given need. The limitations on such changes are noted below:

12.2.1 The mice used must be as stipulated.

12.2.2 No change can be made in acclimation time.

12.2.3 Airflow rates can be varied from 16 to 100 L/min for aerosols, and 2 to 100 L/min for gases.

12.2.4 Exposure time may vary from 3 to 180 min. In order to assure that a maximum response has been obtained, a plateau of response for at least 1 min must be obtained. The minimum decrease in respiratory rate considered significant is 12 %, provided that it is either sustained for 3 min or reproducible in three groups of animals for at least 1 min. In no



case will the decrease in respiratory rate exceed 80 to 85 % of normal regardless of irritant concentration or potency (14).

12.2.5 Concentration of test compound can be varied over any desired effective range.

12.2.6 Any of the solvents listed in 9.2 may be used.

### 13. Procedure

13.1 There are two different types of studies that can be conducted using this test. One type is comparative studies in which the irritant potential of one compound or formulation is tested against a standard at a single concentration. The second type is concentration-response studies where quantitative estimates of irritancy are obtained. Both use essentially the same procedure.

13.1.1 For quantitative concentration-response studies, select the animals to be used at each concentration in some random fashion to assure statistical validity of the results.

13.2 Place the mice in the plethysmograph tubes with their heads inserted through the rubber dam into the exposure chamber. Close the tubes with rubber stoppers, assuring that they are well seated to prevent air leaks.

13.3 Acclimate the animals to the apparatus for 10 min, with only room air being pumped through the system. Start the recorders at a chart speed of 5 mm/s and examine the tracings to assure that the mice are breathing normally. There will be occasional erratic tracings caused by movements of the animal in the plethysmograph; these artifacts are easily recognized and are of no consequence unless they continue for more than 30 s. In the rare case where sustained body movement is noted, replace the animal to assure valid results. Except for these occasional erratic responses, each animal should be breathing at a constant rate of about 240 to 275 respirations/min. A sample tracing of normal respiration is shown in Fig. 1.

13.4 After the animals have been acclimated to the apparatus, initiate the aerosol exposure. The rate of flow to be used will depend on the purpose of the test and the potency of the material being tested. A standard airflow rate of 20 L/min is recommended, but flow rates from 16 to 100 L/min may be used for aerosols, and a rate as low as 2 L/min can be used for gases. At low flow rates, the time to reach equilibrium in the chamber increases; this can disrupt comparison of substances tested at different rates. Therefore, a single flow rate must be chosen for each comparative test series.

13.5 At the termination of the experiment, house the animals exposed together in the same groups of four with suitable bedding, and allow free access to feed and water.

13.6 Hold the mice for a period of 7 days, then weigh them to assess any untoward effects on food intake or metabolism produced by the exposure.

### 14. Interpretation of Results

14.1 There are two ways in which results can be interpreted; one is a graded response (slight, moderate, extreme, or no irritation), and the other is a quantitative test in which the dose required to reduce respiratory rate by 50 % (response dose 50 [RD50]) is calculated. The graded response is used where only a single concentration is tested to assess relative irritancy, but the RD50 is a statistically derived value based on several geometrically spaced concentrations. Fig. 6 shows the results

of a typical exposure to an irritant both for a single mouse and an average for four mice. Fig. 7, Fig. 8, and Fig. 9 show possible variations in slight, moderate, and extreme responses, respectively. Note the characteristic pause in expiration which identifies the test material as a sensory irritant.

14.2 Responses can be evaluated by either manually counting the respiratory rate or by using an automatic rate counter with circuitry designed to eliminate the body movement artifacts. The latter method is preferred, since it eliminates a laborious procedure. Each group of four animals serves as its own control, so that possible differences in normal respiratory rates are of no consequence. Such differences are rarely noted in any case. The control respiratory rate to be used is the average of six 15-s intervals immediately preceding the exposure period.

14.3 Calculate respiratory rates for each 15-s interval of the first five minutes of exposure, and at 3-min intervals for the remainder of the exposure period. During the post-exposure recovery period, calculate the rates at 1-min intervals.

14.4 Decreases in respiratory rate of 12 to 20 % are graded as a slight response, 20 to 50 % as a moderate response, and 50 to 85 % as an extreme response.

14.5 Graded responses are best measured by a modification of the Mann-Whitney U-Test, a nonparametric method (15). All responses from both groups of mice being tested at selected intervals are arranged in order of magnitude, and each is given its appropriate rank, with the lowest given rank No. 1. If two or more responses are equivalent, all will be given the mean rank for that position. The rank values are then totalled, and a mean value derived for each group.

14.6 For RD50 studies, separate groups of four mice are exposed to each of a series of concentrations that are geometrically spaced, and which produce responses ranging from none to the maximum that can be obtained with that particular material. The irritant effect of the compound being tested is then treated statistically as a dose-response regression, with the common logarithm of the exposure concentration as the independent variable,  $X$ , and the percent decrease in respiratory rate from control as the dependent variable,  $Y$ . The regression line, the RD50, and its 95 % confidence limits are determined by the method of least squares (16). The analytical model on which this analysis is based has been carefully described (17). Consult that reference for further details and for other data analysis models.

### 15. Report

15.1 Report the following information as a minimum:

15.1.1 The purpose for which the test was conducted.

15.1.2 The date of testing.

15.1.3 The compound(s) tested, including any reference standards. The test materials should be identified by batch or lot number and manufacturer, if possible.

15.1.4 The concentration(s) of the test compounds to which the animal was exposed.

15.1.5 The solvent or carrier gas used in the study, with lot number and manufacturer identified.

15.1.6 The airflow rate, particle size, exposure time, and recovery periods used.

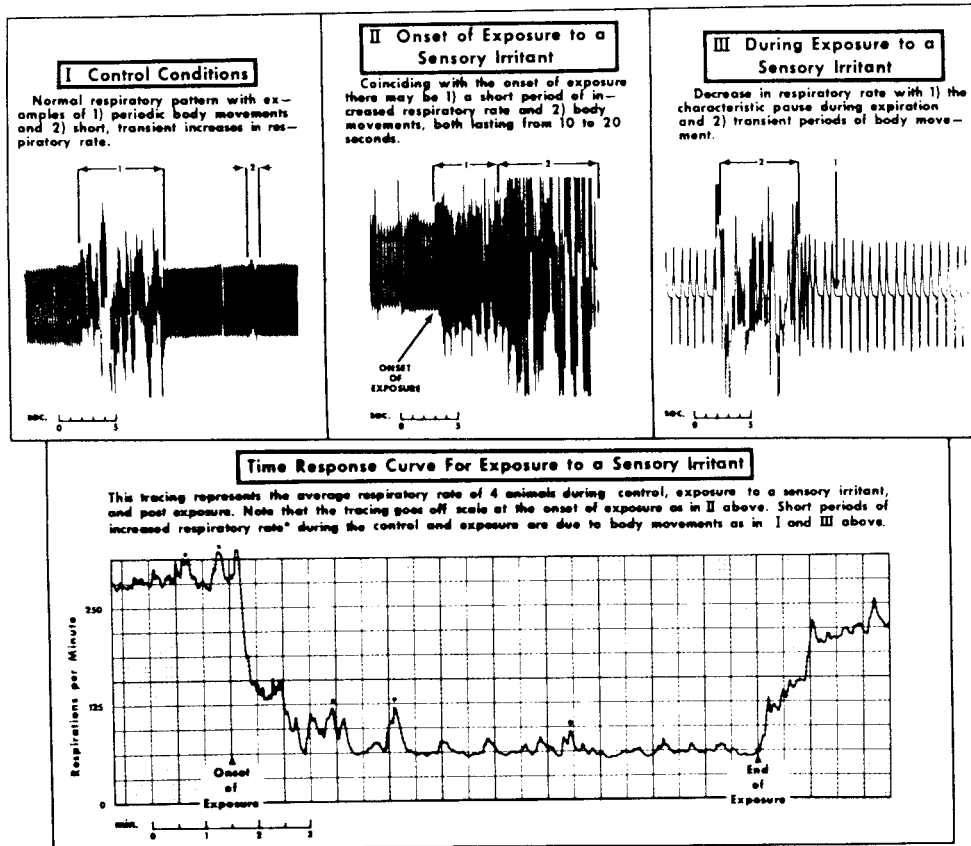

FIG. 6 Typical Tracing Obtained from a Single Animal Prior to and During Exposure to a Sensory Irritant (Top). Average Respiratory Rate of Four Mice During Course of Exposure (Bottom)

15.1.7 The degree of sensory irritation noted at each concentration, or the RF50 if determined.

15.1.8 Statistical method used to analyze the data obtained.

15.1.9 Any effect on weight gain or respiratory rate at 7 days post exposure, or any deaths occurring within that time, and the exposure level producing these effects.

15.1.10 Any variance from the stipulated procedure in conducting the experiment.

**16. Precision and Bias**

16.1 No precision data are available for this method at

present. However, the committee is interested in conducting an interlaboratory test program, and encourages interested parties to contact the Committee E-35 staff manager at ASTM Headquarters.

**17. Keywords**

17.1 airborne; chemicals; inhalation; mice; respiration; sensory irritancy

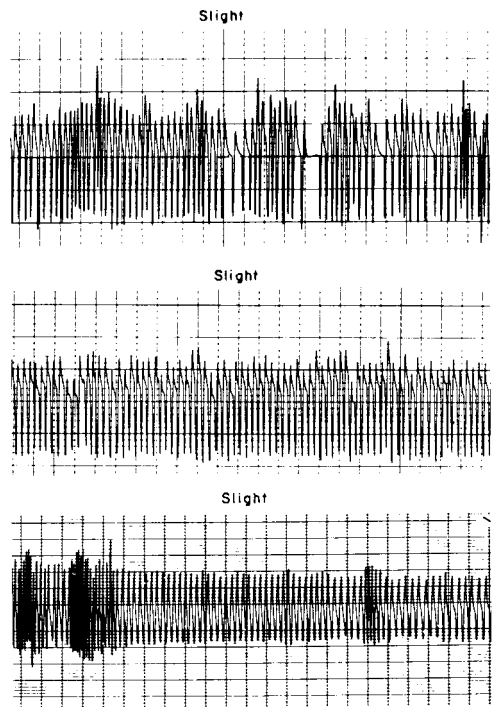

NOTE 1—Decreases in respiratory rate of 12 to 20 % are graded as slight responses.

NOTE 2—Taken from Ref. (1).

**FIG. 7 Typical Tracings with Intensity of the Reaction Graded as Slight**



Moderate

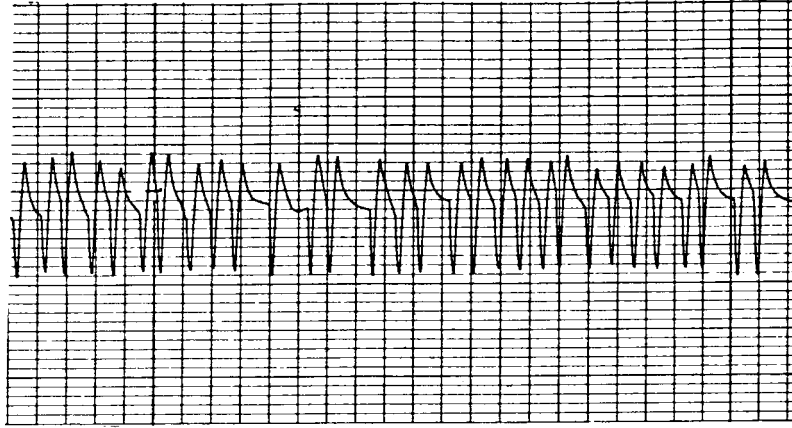

Moderate,

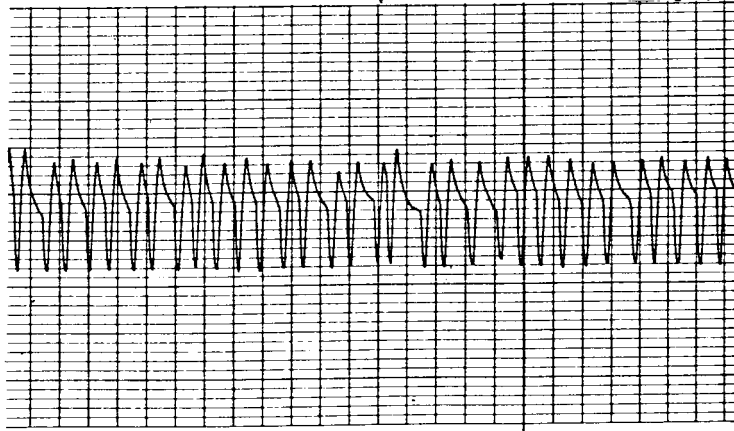

NOTE 1—Decreases in respiratory rate of 20 to 50 % are graded as moderate responses.

NOTE 2—Taken from Ref. (1).

**FIG. 8 Typical Tracings with Intensity of the Reaction Graded as Moderate**

Extreme

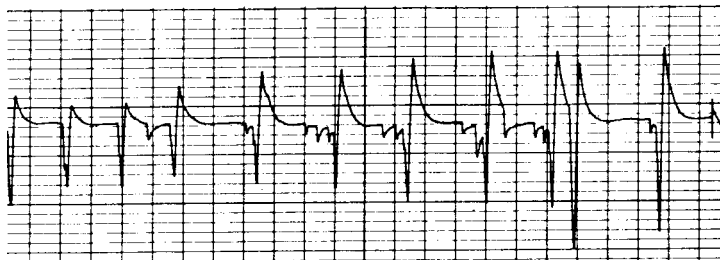

Extreme

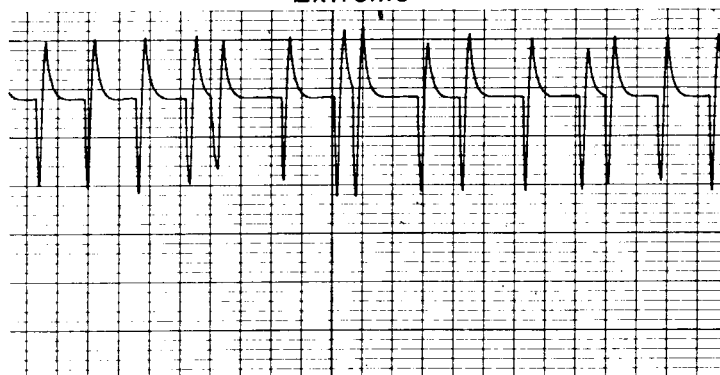

NOTE 1—Decreases in respiratory rate of 50 to 85 % are graded as extreme responses.

NOTE 2—Taken from Ref. (1).

FIG. 9 Typical Tracings with Intensity of the Reaction Graded as Extreme

APPENDIX

(Nonmandatory Information)

X1. LIST OF APPARATUS AND SUPPLIERS

X1.1 *Recorders*—Gould, Grass, Beckman, and Hewlett-Packard have been found to be suitable.

X1.2 *Transducers*—Statham, Validyne, which are capable of detecting 1 cm H<sub>2</sub>O pressure are suitable.

X1.3 *Breath Counters*—Gould Biotachometer, Grass or Beckman Frequency Counter, Hewlett-Packard Digital Frequency Counter, Gould Digital Frequency Counter, and various minicomputers may be used.

X1.4 *Averager*, to display average respiratory rate of 4 mice is available from J. E. Wood Electronic Company, Averager Model 55, Freedom Road, Mars, PA 16046. Model 55 will accept output from Gould Biotachometer or output from any other device in the range 0 to 5 V. Other alternatives are to build your own averager or use minicomputers.

X1.5 *Aerosol Generator*—Pitt No. 1 is available from Scientific Glassblowing Laboratory, McKees Rocks, PA 15136. Other alternatives are aerosol generators such as Collison, Retech, etc.

X1.6 *Exposure Chamber*—Glass exposure chamber, available from Scientific Glassblowing Laboratory, McKees Rocks, PA 15136, has been found suitable.

X1.7 In the working system from which Fig. 4 was made, the pressure transducers are Stratham PM-15 or PM-197. Carrier amplifiers and oscillographs are Gould. Frequency-to-voltage converters are Gould Biotachometer operating in the averaging mode instead of the pulse mode. Voltage addition and division equipment to obtain the signal average for four mice was obtained from Wood Electronic Company.

## REFERENCES

- (1) Alarie, Y., "Irritating Properties of Airborne Materials to the Upper Respiratory Tract," *Archives of Environmental Health*, Vol 13, 1966, pp. 433-449.
- (2) Alarie, Y., Kane, L. E., and Barrow, C. S., "Sensory Irritation: The Use of an Animal Model to Establish Acceptable Exposure to Airborne Chemical Irritants," *Toxicology: Principles and Practice*, Vol 1, John Wiley and Sons, Inc., New York, NY, 1980, pp. 82-83.
- (3) Alarie, Y., "Sensory Irritation by Airborne Chemicals," *CRC Critical Reviews in Toxicology*, 1973, pp. 299-363
- (4) Kane, L. E., Barrow, C. S., and Alarie, Y., "A Short Term Test to Predict Acceptable Levels of Exposure to Airborne Sensory Irritants," *American Industrial Hygiene Association Journal*, Vol 40, 1979, pp. 207-229.
- (5) Kane, L. E., and Alarie, Y., "Sensory Irritation of Select Experimental Photochemical Oxidants," *Archives of Environmental Health*, Vol 33, 1978, pp. 244-249.
- (6) Kane, L. E., and Alarie, Y., "Sensory Irritation to Formaldehyde and Acrolein During Single and Repeated Exposures in Mice," *American Industrial Hygiene Association Journal*, Vol 38, 1977, pp. 509-522.
- (7) Kane, L. E., Dombroske, R., and Alarie, Y., "Evaluation of Sensory Irritation from Some Common Industrial Solvents," *American Industrial Hygiene Association Journal*, Vol 41, 1980, pp. 451-455.
- (8) Alarie, Y., "Toxicological Evaluation of Airborne Chemical Irritants and Allergens Using Respiratory Reflex Reactions," *Symposium on Inhalation Toxicology and Technology*, Ann Arbor Publishers, Ann Arbor, Michigan, 1981, pp. 207-231.
- (9) Alarie, Y., "A Bioassay for Evaluating the Potency of Airborne Sensory Irritants and Predicting Acceptable Levels of Exposure in Man," *Food and Cosmetics Toxicology*, Vol 19, 1981, pp. 623-626.
- (10) Kane, L. E., and Alarie, Y., "Interactions of Sulfur Dioxide and Acrolein as Sensory Irritants," *Toxicology and Applied Pharmacology*, Vol 48, 1979, pp. 305-315.
- (11) Wong, K. L., and Alarie, Y., "A Method for Repeated Evaluation of Pulmonary Performance in Unanesthetized, Unrestrained Guinea Pigs and Its Application to Defect Effects of Sulfuric Acid Mist," *Toxicology and Applied Pharmacology*, In Press, 1982.
- (12) *Guide for the Care and Use of Laboratory Animals*, Institute of Laboratory Animal Resources, National Research Council, DHEW Publication No. (NIH) 1978, pp. 72-73.
- (13) Sangha, G. K., Matijak, M., and Alarie, Y., "Comparison of Some Mono- and Diisocyanates as Sensory Irritants," *Toxicology and Applied Pharmacology*, Vol 57, 1981, pp. 241-246.
- (14) Barrow, C. S., Alarie, Y., Warrick, J. C., and Stock, M. F., "Comparison of the Sensory Irritation Response in Mice to Chlorine and Hydrogen Chloride," *Archives of Environmental Health*, Vol 32, 1977, pp. 68-76.
- (15) Snedecor, G. W., and Cochran, W. G., *Statistical Methods*, 7th Ed., Iowa State University Press, Ames, Iowa, 1980, pp. 144-146.
- (16) *Ibid*, pp. 158-160.
- (17) Alarie, Y., "Sensory Irritation of the Upper Airways by Airborne Chemicals," *Toxicology and Applied Pharmacology*, Vol 24, 1973, pp. 279-297.
- (18) Barrow, C. S., et al., "Sensory Irritation Evoked by the Thermal Decomposition Products of Plasticized Poly(Vinyl) Chloride," *Fire and Materials*, Vol 1, 1976, pp. 147-153.

*The American Society for Testing and Materials takes no position respecting the validity of any patent rights asserted in connection with any item mentioned in this standard. Users of this standard are expressly advised that determination of the validity of any such patent rights, and the risk of infringement of such rights, are entirely their own responsibility.*

*This standard is subject to revision at any time by the responsible technical committee and must be reviewed every five years and if not revised, either reapproved or withdrawn. Your comments are invited either for revision of this standard or for additional standards and should be addressed to ASTM Headquarters. Your comments will receive careful consideration at a meeting of the responsible technical committee, which you may attend. If you feel that your comments have not received a fair hearing you should make your views known to the ASTM Committee on Standards, 100 Barr Harbor Drive, West Conshohocken, PA 19428.*

*This standard is copyrighted by ASTM, 100 Barr Harbor Drive, West Conshohocken, PA 19428-2959, United States. Individual reprints (single or multiple copies) of this standard may be obtained by contacting ASTM at the above address or at 610-832-9585 (phone), 610-832-9555 (fax), or service@astm.org (e-mail); or through the ASTM website (<http://www.astm.org>).*