



Standard Guide for Preparation of Working Reference Materials for Use in the Analysis of Nuclear Fuel Cycle Materials¹

This standard is issued under the fixed designation C 1128; the number immediately following the designation indicates the year of original adoption or, in the case of revision, the year of last revision. A number in parentheses indicates the year of last reapproval. A superscript epsilon (ϵ) indicates an editorial change since the last revision or reapproval.

1. Scope

1.1 This guide covers the preparation and characterization of working reference materials (WRM) that are produced by a laboratory for its own use in the analysis of nuclear materials. Guidance is provided for establishing traceability of WRMs to certified reference materials by a defined characterization process. The guidance provided is generic; it is not specific for a given material.

1.2 The information provided by this guide is found in the following sections:

	Section
Planning	6
Preparation	7
Packaging and Storage	8
Characterization	9
Statistical Analysis	10
Documentation	11

1.3 The values stated in SI units are to be regarded as the standard.

1.4 *This standard does not purport to address all of the safety concerns, if any, associated with its use. It is the responsibility of the user of this standard to establish appropriate safety and health practices and determine the applicability of regulatory limitations prior to use.*

2. Referenced Documents

2.1 ASTM Standards:

C 859 Terminology Relating to Nuclear Materials²

C 1009 Guide for Establishing a Quality Assurance Program for Analytical Chemistry Laboratories Within the Nuclear Industry²

C 1068 Guide for Qualification of Measurement Methods by a Laboratory Within the Nuclear Industry²

C 1215 Guide for Preparing and Interpreting Precision and Bias Statements in Test Method Standards in the Nuclear Industry²

2.2 ISO Standards:

ISO Guide to the Expression of Uncertainty in Measurement³

ISO 17025 General Requirements for the Competence of Calibration and Testing Laboratories³

ISO Guide 30 Terms and Definitions Used in Connection with Reference Materials³

3. Terminology⁴

3.1 Definitions of Terms Specific to This Standard:

3.1.1 *certified reference material (CRM)*⁵—a reference material with one or more property values that are certified by a technically valid procedure, accompanied by or traceable to a certificate or other documentation that is issued by a certifying body (as defined by ISO Guide 30). A certifying body is a technically competent body (organization or firm, public or private) that issues a reference material certificate (as defined by ISO Guide 30). A reference material certificate is a documented certifying one or more property values for a certified reference material, stating that the necessary procedures have been carried out to establish their validity (as defined by ISO Guide 30).

3.1.2 *reference material (RM)*⁵—a material or substance one or more properties of which are sufficiently well established to be used for the calibration of an apparatus, the assessment of a measurement method, or assigning values to materials (as defined by ISO Guide 30). A reference material may be referred to in this guide also as a standard, such as calibration standard or control standard.

3.1.3 *working reference material (WRM)*⁵—a RM usually prepared by a single laboratory for its own use as a calibration standard, as a control standard, or for the qualification of a measurement method (see Guide C 1068) as indicated in Fig. 1.

4. Summary of Guide

4.1 This guide covers the preparation of WRMs from nuclear fuel cycle materials. These materials are compounds and metal of uranium and plutonium, absorber materials such

¹ This guide is under the jurisdiction of ASTM Committee C26 on Nuclear Fuel Cycle and is the direct responsibility of Subcommittee C26.8 on Quality Assurance Applications.

Current edition approved June 10, 2001. Published September 2001. Originally published as C 1128 – 89. Last previous edition C 1128 – 95.

² *Annual Book of ASTM Standards*, Vol 12.01.

³ Available from American National Standards Institute, 11 W. 42nd St., 13th Floor, New York, NY 10036.

⁴ See C 859 for other terms specific to the nuclear fuel cycle.

⁵ It is important that a well defined uncertainty in the stated value(s) be given in the certificate.

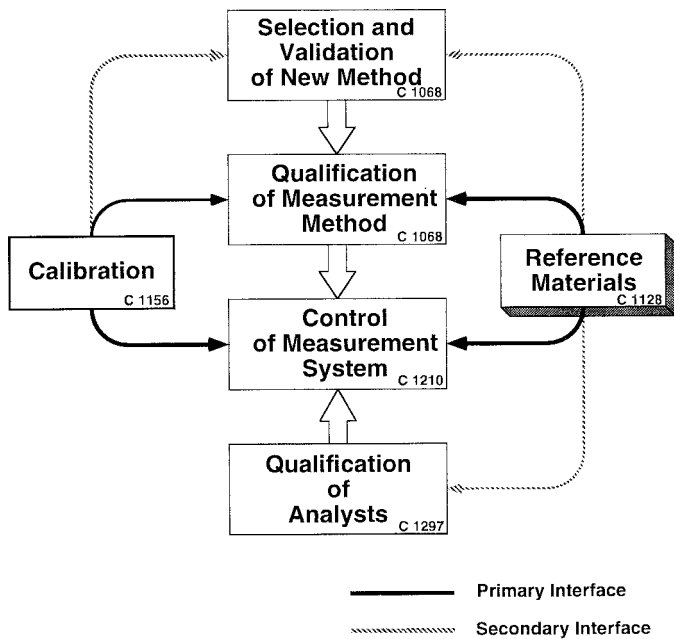

FIG. 1 Quality Assurance of Analytical Laboratory Data

as boron carbide, and cladding materials such as zirconium and stainless steel. The criteria governing the preparation of reliable WRMs are identified and discussed. Because this guide is generic, requirements and detailed information for specific nuclear materials are not given. A flow diagram to illustrate an approach to producing WRMs is given in Fig. 2.

5. Significance and Use

5.1 Certified reference materials (CRMs) prepared from nuclear materials are generally of high purity, possessing chemical stability or reproducible stoichiometry. Usually they are certified using the most unbiased and precise measurement methods available, often with more than one laboratory being involved in making certification measurements. CRMs are generally used on a national or international level, and they are at the top of the metrological hierarchy of reference materials. A graphical representation of a national nuclear measurement system is shown in Fig. 3.

5.2 Working reference materials (WRMs) need to have quality characteristics that are similar to CRMs, although the rigor used to achieve those characteristics is not usually as stringent as for CRMs. Where possible, CRMs are often used to calibrate the methods used for establishing the concentration values (reference values) assigned to WRMs, thus providing traceability to CRMs as required by ISO 17025. A WRM is normally prepared for a specific application.

5.3 Because of the importance of having highly reliable measurement data from nuclear materials, particularly for control and accountability purposes, CRMs are sometimes used for calibration when available. However, CRMs prepared from nuclear materials are not always available for specific applications. Thus, there may be a need for a laboratory to prepare WRMs from nuclear materials. Also, CRMs are often too expensive, or their supply is too limited for use in the quantities needed for long-term, routine use. When properly prepared, WRMs will serve equally well as CRMs for most

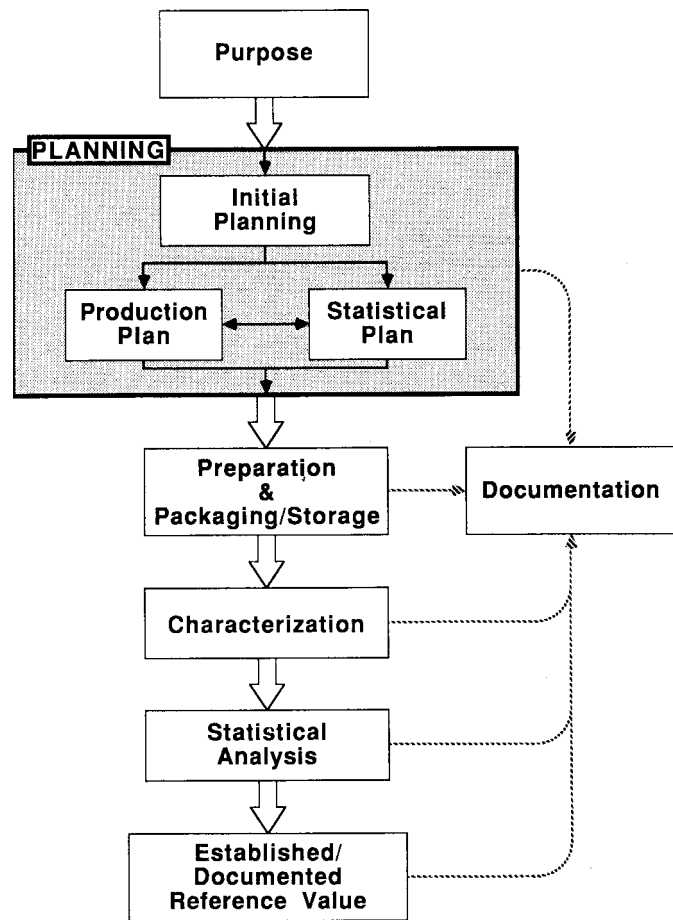

FIG. 2 Producing a Working Reference Material

applications, and using WRMs will preserve supplies of CRMs.

5.4 Difficulties may be encountered in the preparation of RMs from nuclear materials because of the chemical and physical properties of the materials. Chemical instabilities, problems in ensuring stoichiometry, and radioactivity are factors involved, with all three factors being involved with some materials. Those preparing WRMs from nuclear materials must be aware of how these factors affect preparation, as well as being aware of the other criteria governing the preparation of reliable WRMs.

6. Planning

6.1 Producing a WRM requires forethought to ensure the credibility of the completed WRM. Planning also ensures that the necessary resources are available. Time, funding, and materials can be wasted easily without thorough planning. Planning should include developing an outline or general scheme for preparing the WRM. The intended use of the WRM, the sources available for obtaining needed materials, and the equipment required are some areas of planning that should be considered. These considerations and others, i.e., initial planning, a production plan, and a statistical plan (see Fig. 2), are discussed in this section. Initial planning generally starts with the application or need for a WRM and the quantity needed. As planning progresses into the actual preparation, a

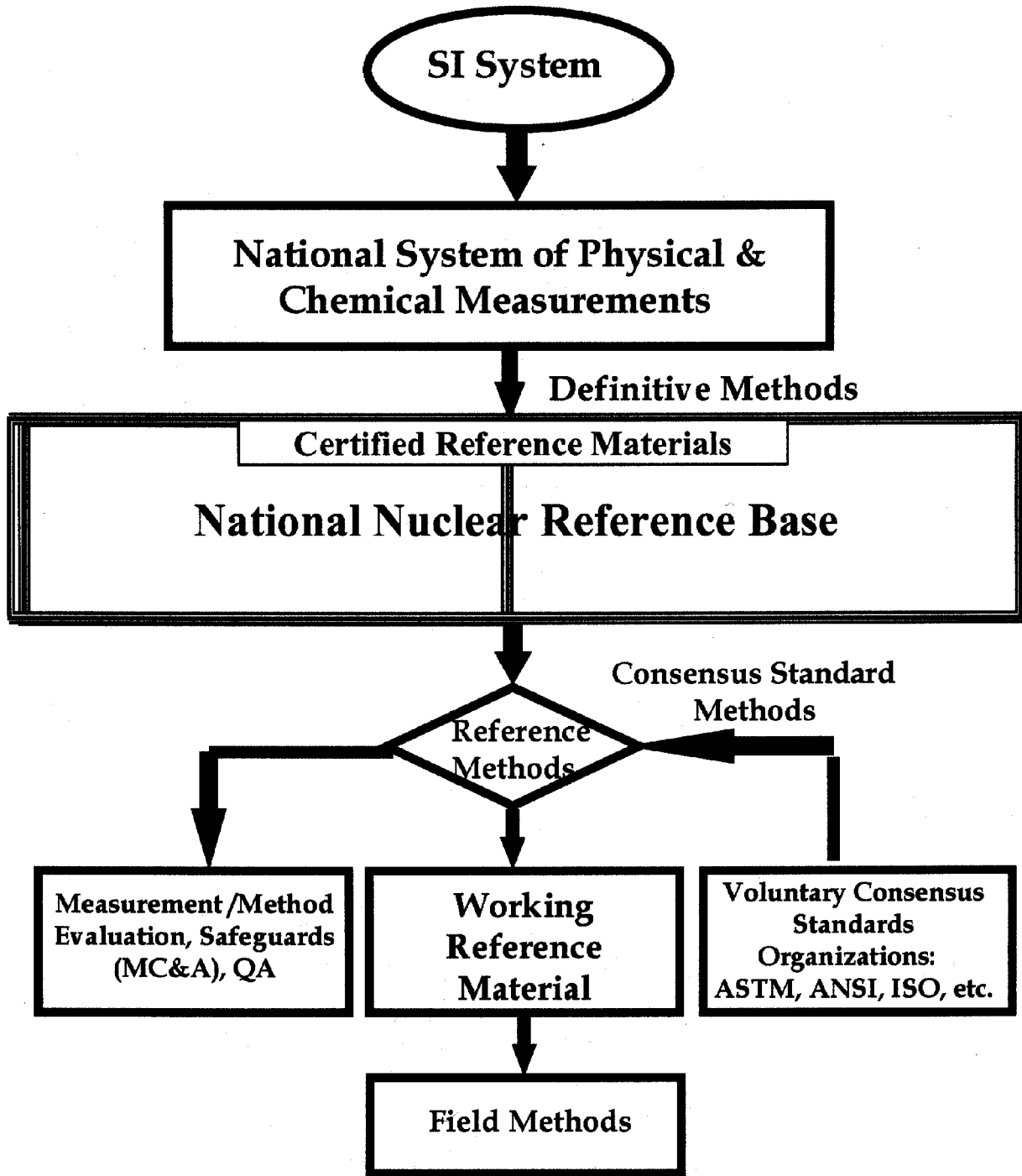

FIG. 3 United States Nuclear Measurement System

production plan and a statistical analysis plan will be developed.

6.2 Initial Planning:

6.2.1 Application of WRM—A WRM can be prepared for a single method of analysis or for several methods. For example, one might be prepared for the determination of uranium in uranium dioxide. If a standard is also required for the isotopic analysis of uranium, it might be possible to prepare and

characterize that WRM for isotopic analysis as well. During the preparation of a WRM for the determination of a major constituent, it might be possible to add desired impurities and to establish values for those impurities. Careful consideration should be given to the preparation of multi-purpose WRMs, however, because they tend to be difficult to prepare and characterize.

6.2.2 *Quantity*—The quantity of WRM prepared will depend on such factors as the length of time required for its use, the frequency of use, the amount of material available, and the WRM's anticipated shelf life. Consideration should be given to the amount of WRM that will be needed for characterization and for archival purposes. Needs may develop during the use of a WRM such as the exchange of materials with another laboratory for an interlaboratory testing program. For this and other possible contingencies, the preparation of a quantity over the anticipated amount should be planned.

6.3 *Production Plan*—An outline that specifies how the WRM will be produced should be prepared during planning. The subjects discussed in 6.2 and in this section should be considered and addressed if appropriate. A preparation procedure should be written and included as a part of the production plan (see 7.4). The production plan must be integrated with the statistical plan (see 6.4).

6.3.1 *Materials*—The selection of materials is an important part of planning because proper selection is critical to achieving credible WRMs. Selection depends on availability (source), cost, chemical and physical properties, and stability or reproducible stoichiometry. The material selected for a WRM must be as similar as possible to the sample material in chemical and physical properties, particularly in those that will affect the method of analysis. One way to achieve similarity in composition is to prepare the WRM material by the same or similar process used to prepare the sample material. Probably the most important criterion for selection is stability. The WRM composition must be sufficiently stable to make the preparation of the WRM cost effective, and the stability must be known well enough to establish a shelf life with a high degree of confidence. Somewhat unstable materials whose stoichiometries can be reproduced easily can be used for WRMs.

6.3.2 *Equipment*—Generally, standard laboratory equipment will be involved in preparing a WRM. Analytical setups and instrumentation will be required, possibly to analyze starting materials for impurities and other constituents and certainly to analyze the prepared material during final characterization of the WRM. Depending on packaging requirements, equipment may be required for such things as sealing glass ampoules or packaging a WRM in a special atmosphere.

6.3.3 *Use*—The degree of attention given to some steps in producing a WRM may vary depending on its planned use. Usually, WRMs are used for calibration and measurement control. A common approach to producing a control standard is to take material from a batch of production material, treat it as necessary to ensure homogeneity, and establish initial measurement control limits by using the same method and conditions used for sample analysis. To produce a calibration standard, more care in preparation and rigor in characterization are required.

6.3.4 *Characterization of Materials*—Planning must provide for the characterization of materials used for a WRM (See Appendix X1). Characterization may include the analysis of starting materials for impurities and major constituents. It should include a scheme for establishing the value to be assigned (reference value) to each constituent of interest. In planning for characterization, consideration must be given to

the degree of reliability required for a reference value. This will involve planning for the statistical collection and analysis of characterization data (see 6.4).

6.3.5 *Packaging*—Packaging of the WRM should be planned. Decisions need to be made concerning the division of the WRM into portions, selecting containers, uniquely identifying containers, sealing containers, and using additional means to protect the integrity of the WRM. It may be necessary to package some WRMs soon after preparation to preserve integrity; in that case, packaging materials and equipment should be readied prior to material preparation. Inadequate packaging may lead to loss of the WRM's integrity through such consequences as contamination, evaporation, degradation and absorption.

6.4 *Statistical Plan*—A statistical plan for characterization should be developed during planning. Such a plan is necessary to allow an uncertainty to be determined for each reference value. The statistical plan establishes how characterization will be done. It includes sampling of the WRM, the frequency and number of measurements to be made of the WRM, any reference material to be measured with the WRM, and the order of measurements (see 9.3 and 9.4). The validation or calibration of the measurement method to be used for characterization may be addressed in the plan also (see 9.2.3). It is essential to have a qualified statistician involved in developing the plan, and the statistician should be brought into the planning process early (see Fig. 2). Developing a statistical plan is an iterative process that will go on throughout planning, and it must be integrated with the production plan (see 6.3).

7. WRM Preparation

7.1 The objective of preparation is to make physical and chemical manipulations so as to produce a homogeneous and stable material in the form required for a WRM. For a given WRM, the physical and chemical manipulations that will be used depend on the starting material(s), the WRM form required, and the physical and chemical properties of the materials involved. Various aspects of preparation are discussed in this section.

7.2 *Starting Materials*—The starting materials for the preparation of WRMs may be the WRM forms desired or may be other materials that are processed into those forms. In the former case, the starting material is process material. For example, a batch of uranium dioxide pellets, boron carbide powder, or plutonium nitrate solution might be taken directly from a process run, treated as necessary, characterized, and packaged as a WRM. In the latter case, various approaches are used to produce the form desired. For example, high-purity uranium hexafluoride might be dissolved and the solution converted to urano-uranyl oxide (U_3O_8) to prepare a WRM or matrix material (see Appendix X2).

7.3 *WRM Form*—The form of the WRM can be any stable state of the element of interest or a somewhat unstable state whose stoichiometry is easily reproducible. The forms most commonly used for nuclear materials have been oxides as powder or pellets, metal, and nitrate solutions.

7.4 *Procedure*—A preparation procedure should be written using a scheme for preparing the WRM developed during the planning stage (see 6.3). The procedure should include the

necessary steps for making the required chemical and physical manipulations, and it should include requirements for recording data generated during preparation. If it is planned that the reference value will be calculated based on process or make-up parameters (weights, volumes, etc.), write the procedure accordingly to minimize the possibilities of losing any material during processing (see 9.1). Procedures to illustrate the preparation of two WRM solutions are given in Appendix X3.

8. Packaging and Storage

8.1 *Packaging*—Once preparation is complete, the WRM is packaged for use. A frequent practice is to divide the WRM material into essentially equal portions or units, each of which represents enough material for a one-time use. If a WRM is sufficiently stable, it could be divided into larger portions for multiple use. There is a risk here, however, because each time a container is opened there is a potential for loss of WRM integrity. The key to packaging is to contain the WRM portions in such a manner as to preserve their integrity for the life of the WRM (see 6). A technique sometimes used for solutions is to evaporate each weighed portion to near-dryness in its packaging container, giving a weighed amount of the element of interest for a one-time use. Various aspects of packaging are discussed in this section. A procedure to illustrate packaging a WRM solution is given in Appendix X3.

8.1.1 *Container*—Containers often used for WRMs are screw-cap glass vials or bottles and glass ampoules. It is important that the container material is compatible chemically with the WRM matrix and that the material will not contribute to the contamination of the WRM. To avoid contamination, containers are often specially cleaned before packaging. When radioactive material such as plutonium is involved, the primary container is often packaged in a secondary or outer container to protect against radioactive contamination.

8.1.2 *Addition to Container*—The manner of adding WRM material to containers depends on the nature of the material, the type of container, and whether the weight of each WRM portion is required. It is exceedingly important that the WRM material be delivered into each container without any part of the material adhering to the neck or top of the container (or outside of the container), particularly when solution is added to glass ampoules that will be heat sealed. Special apparatus is sometimes used for delivery to glass ampoules (see Fig. 4 as an example). When a WRM is to be apportioned by weight, WRM material is usually added to tared containers, which are reweighed after addition. When radioactive material is involved, special care is required to keep the outsides of the containers free of contamination. Each container should be surveyed after addition, and those contaminated should be discarded.

8.1.3 *Cover Gas*—With some materials, stability is enhanced by packaging the WRM in an inert gas or dry air. A common way to do this is to package in a glove box containing the atmosphere desired. The materials most often packaged in an inert and dry atmosphere or simply in dry air are the oxides, particularly powders. This is done to ensure stability and integrity, even when an oxide is basically stable. When a special atmosphere is used, care must be taken to ensure that containers will not lose the atmosphere over the shelf life of the WRM.

8.1.4 *Sealing Containers*—If a special atmosphere is used as discussed in 8.1.3, the method of sealing the containers is important. For screw cap containers, sealing the caps with a sealant over the cap is one way. Using glass ampoules that are heat sealed is another approach (a procedure for sealing glass ampoules is given in Appendix X3). Glass ampoules are commonly used for solutions to avoid loss of integrity through evaporation. When simply closing a vial or bottle with a screw

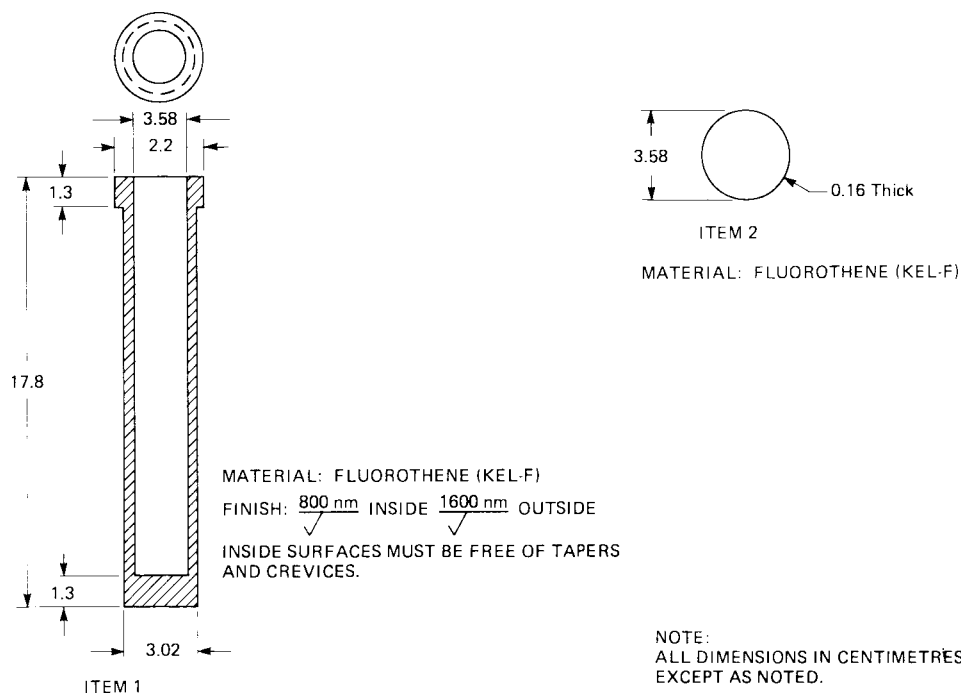

FIG. 4 Fluorothene Knockout Cylinder

cap is satisfactory, a cap liner that provides a reasonably air-tight seal should be used.

8.1.5 *Labeling*—Each WRM container should be labeled for identification. Individual identification of each container or unit is not usually required unless each unit is uniquely identifiable by a characteristic that affects the use of the WRM, such as the net weight of the WRM in the container. As a minimum, information on a label must provide traceability to the WRM. It would be desirable to have the date of preparation and any limitations on shelf life indicated on the label. It is essential that labels be firmly attached to the containers and that their markings be nonsmearing and nonfading. Bar-code labeling may be desirable since more information can be added in a smaller space.

8.2 *Storage*—Although a major purpose of packaging is to preserve the integrity of WRMs, attention should also be given to how and where the packaged WRMs are stored. Exposure over time to large fluctuations in temperature, or to above-ambient temperatures, could adversely affect the container seals and the WRM materials themselves. Exposure to conditions that would damage or destroy labels, or even damage containers, should be avoided.

9. Characterization

9.1 Characterization, as discussed in this section, applies to the analysis or measurement of a prepared WRM to establish a reference value for the WRM. Characterization normally begins after the prepared WRM has been packaged. The required number of WRM units is selected, and the specified number of measurements (analyses) is made using the designated measurement method or methods. If a WRM is to be used for calibration purposes because a CRM is not available, the decision might be made to use two methods if two comparable and applicable methods are available. In some instances, the reference value is based on a make-up value in which the starting material is weighed and processed quantitatively through the preparation procedure with a final weight or volume determination. Even then, the make-up value is often confirmed or verified by measurement. The selection and use of the measurement method is briefly discussed below. An outline to illustrate a chemical characterization of a WRM is given in Appendix X1.

9.2 *Measurement Method:*

9.2.1 *Type*—Often the measurement method selected is the method used for the analysis of the samples for which the WRM is prepared. If another method is used, it should be equal to or better than the sample method in terms of precision and bias.

9.2.2 *Conditions of Measurement*—A decision, which is based on the intended use of the WRM, must be made regarding how much care will be taken when measuring the WRM. If the WRM is to be used as a control standard, the measurements might be made under the routine conditions used for sample analysis. The alternative is to make the measurements under more rigidly controlled conditions. For example, the method might be qualified first using the criteria given in Guide C 1068, and then only highly qualified analysts might be permitted to make the measurements.

9.2.3 *Validation of Method*—Before the measurement

method is used for characterization, the method must be validated in the sense that it is calibrated by using a selected calibration standard and by following a prescribed calibration procedure. The ideal standard would be a CRM that has the same matrix as the WRM. A second choice could be a CRM with a different matrix but still certified for the element of interest. If possible, the calibration standard should have a higher standing in the metrological hierarchy of standards than the WRM will have. A calibration procedure should be prepared and integrated with the statistical plan (see 6.4).

9.3 *Sampling*—Sampling is addressed in the statistical plan. After preparation and packaging, a random sample of the required number of WRM units will be selected for characterization. Consideration should be given to minimizing the number of units taken for characterization to maximize the number available for the planned use of the WRM.

9.4 *Measurement Scheme*—The measurement scheme is addressed in the statistical plan. There are various factors that could be considered when devising a measurement scheme. In addition to the possibility of using more than one measurement method, more than one analyst might be used. Instead of two different methods, there might be duplicate setups for one method. The degree of replication of each step in the analysis and the time period for the analysis would be considerations. These and other factors will affect the measurement scheme and the amount of work required. A balance should be decided upon between the cost of characterization and the degree of reliability desired.

10. Statistical Analysis

10.1 A statistical analysis of the characterization data is made to derive the reference value and to determine an appropriate uncertainty for that value. The statistical analysis is based on the statistical plan, and it should be done by a statistician if possible. The meaning of the uncertainty value assigned to the reference value should be defined (see Guide C 1215 and ISO Guide to the Expression of Uncertainty in Measurement).

11. Documentation

11.1 Records generated during the preparation and chemical or isotopic characterization of a WRM provide the documentary evidence and support for the technical interpretation, judgments, and decisions regarding the quality of the WRM. Records provide the historical evidence needed for future reviews and evaluations should the credibility of the WRM ever be questioned. They provide linkage (traceability) between the WRM's assigned value(s) and a nationally recognized measurement base as represented by CRMs or other recognized standards (see 9.2.3). Thus, consideration should be given to the records that will be generated and retained from planning through measurement and data analysis. The types of records that might be generated and the record controls that should be established are discussed in this section.

11.2 *Types:*

11.2.1 *Preparation*—The more obvious types of preparation records are the preparation procedure and the data generated during preparation such as weights of materials, volumes of solutions, blending or mixing times, and temperature and other

process conditions used (see 7.4). Information about starting materials such as source, treatment history, composition, and physical characteristics are important record items. Other types are data generated from preliminary or test preparation work, process control data, literature references supporting the preparation techniques used, names of those doing the work and dates the work was done.

11.2.2 Characterization—Characterization data are important records. The method(s) used for characterization should be documented, and the statistical plan used to obtain and evaluate the data should be included in the records. Those doing the characterization work and the statistical evaluation of data, as well as the dates the work was done, should be identified in the records.

11.2.3 Other Records—There may be information generated during the planning stage that should become records. An example might be memos or letters that initiated planning for the WRM and that contain documentation of the need for the WRM. External documents associated with the production of the WRM could be useful records. Examples are CRM

certifications and certifications for standard weights. There will be records related to packaging and storage that must be included. These are the records identifying individual units of the packaged WRM and information related to storage and shelf life requirements. Basically, any piece of information or document that would help support the credibility of the WRM should be considered for inclusion in the records.

11.3 Record Control—Records generated for a WRM should be incorporated into the laboratory's records management system (see Guide C 1009). It is important to establish a retention time for each type of record to preserve traceability and documentary evidence for as long as the values may be referenced (see 11.1). The record system must provide for easy retrievability of the records and adequate storage facilities to protect the records from damage. If adequate records are not available when needed, loss of credibility is very possible.

12. Keywords

12.1 certified reference material (CRM); characterization; documentation; package; reference material (RM)

APPENDICES

(Nonmandatory Information)

X1. CHARACTERIZATION OF A WRM

X1.1 The purpose of this appendix is to illustrate, through an example, the chemical characterization of a prepared WRM as a calibration standard and as a control standard. It is assumed that the WRM was prepared by following this guide for its planning, preparation, and packaging. That includes the preparation of a statistical plan, in which a statistician was closely involved. The measurement schemes presented are for illustration and would normally be a part of the statistical plan.

X1.2 Prepared WRM—For the purpose of this illustration, the WRM was prepared from uranium dioxide taken from a fuel fabrication process in which fuel pellets are produced from uranium dioxide. The WRM was packaged in 1-g units. It was decided to prepare 500 units. The element of interest is uranium, for which the reference value will be determined by characterization. It is planned that the WRM will be used during the routine analysis of uranium dioxide.

X1.3 Method of Sample Analysis—The method of analysis is the modified Davies-Gray method, which requires putting solid samples into solution for the uranium measurement (titration). The following conditions are assumed for this illustration. Samples are dissolved one day and titrated the next day. On the average, 20 titrations can be made per day by a single analyst. The measurement is based on the titration of uranium with NIST potassium dichromate, which is a CRM. Under routine conditions, the method is capable of a relative standard deviation (RSD) of 0.15 % for 100-mg samples, with no significant bias. A high-precision version of the method is capable of a RSD of 0.05 %.

X1.4 Characterization of WRM—Following a statistical

sampling plan, units of the WRM are sampled for chemical characterization, which will establish the reference value and its associated uncertainty. The measurement method for chemical characterization is the method used for sample analysis (modified Davies-Gray).

X1.4.1 Characterization for Calibration Standard—For this example, the following measurement scheme is assumed for characterization of the WRM as a calibration standard:

X1.4.1.1 One of the most experienced analysts will make the measurements using the high-precision version of the method.

X1.4.1.2 A solution of a uranium metal CRM (U-CRM) will be prepared and a makeup value calculated. This solution will be titrated to compare one CRM with another CRM (NIST dichromate CRM) as a validation step for the method.

X1.4.1.3 The WRMs will be dissolved one day and titrated the next. For each titration of the WRM solutions and the U-CRM, 100 mg of uranium will be taken.

X1.4.1.4 Initially, the analyst will titrate ten aliquants of the U-CRM. If there is not a significant difference at the 0.05 level of significance between the mean of the results and the makeup value, chemical characterization will continue.

X1.4.1.5 The statistician, or the analyst, if a statistician is not available, will select randomly for analysis n WRMs from the 500 units using a table of random numbers. Determining the value of n will depend on the expected variability of the analytical method (RSD), how close (e) the user wants the determined reference value, \bar{x} , of the WRM to be to the true value, μ , and the degree of confidence $[(1 - \alpha) 100 \%$] wanted in the established reference value.

X1.4.1.6 The value of n will be calculated based on the following: RSD = 0.05 %, e = 0.03 % relative, and α = 0.05. The value of n is 11 using the following equation:

$$n \geq \left(\frac{\zeta_{0.025} \cdot \sigma}{e} \right)^2 = \left(\frac{1.96 \cdot 0.0005 \mu}{0.0003 \mu} \right)^2 = 10.67 \quad (\text{X1.1})$$

where it is assumed that the results are at least approximately normally distributed (see Note X1.1).

NOTE X1.1— $\zeta_{0.025} = 1.96$ is that value such that (for a normal random variable, X having mean μ and standard deviation σ) $P((1X - \mu) > 1.96\sigma) = 2(0.025) = 0.05$.

X1.4.1.7 The analyst will titrate the 11 WRM solutions in a randomized order along with 6 U-CRMs in one day. The order of titration will be as follows: U W W U W W U W W U W W U W W U. The U-CRM solution will be titrated with the WRM solutions to serve as a control during their titration, giving additional confidence in the chemical characterization.

X1.4.1.8 The resulting data from the analyst will be evaluated statistically, and a reference value for the WRM will be calculated and an uncertainty will be established.

NOTE X1.2—A statistician should be involved with X1.4.1.5-X1.4.1.8. There are a number of variables that must be considered in planning the specific details for each situation. For example, the value of n and the

number of titrations made of the WRM solutions and U-CRM may depend on limitations in cost and time. Such limitations could affect the degree of confidence that must be accepted in the reference value.

X1.4.2 *Characterization for Control Standard*—The following measurement and data treatment scheme will be assumed for the chemical characterization of the WRM as a measurement control standard. In reality, if an established measurement control program exists, the scheme would be dictated by that program.

X1.4.2.1 The routine version of the method will be used to analyze the WRM for preparation of the initial control chart.

X1.4.2.2 Twenty WRMs will be randomly selected from the 500 units using a table of random numbers.

X1.4.2.3 Two WRMs will be analyzed each work day for 10 consecutive work days.

X1.4.2.4 The analysts doing the routine work will make the analyses. The analysts will be assigned as normally assigned to run samples.

X1.4.2.5 Using analysis of variance techniques, the resulting data can be analyzed to confirm that the process mean is constant during this period. The standard deviation of the daily measurements can be compared to the method standard deviation to check for consistency.

X2. PREPARATION OF A HIGH-PURITY U_3O_8

X2.1 This appendix describes the preparation of chemically ultrapure urano-uranic oxide (U_3O_8) in batches of 200 g, for use as a WRM or matrix material. For larger quantities of oxide, several batches can be composited by blending, grinding, sieving, and reblending. The procedure, as presented, utilizes uranium hexafluoride (UF_6) as the starting material. Other uranium compounds, however, such as the oxides or the nitrate salt, can be used by starting at the appropriate step in the procedure.

X2.2 *Summary of Oxide Preparation*—Uranium hexafluoride is purified by vapor-phase transfer from a larger cylinder to a clean knockout cylinder by using an appropriate vacuum manifold. The UF_6 is hydrolyzed in ice-cold distilled water and the resultant uranyl fluoride (UO_2F_2) solution is evaporated to dryness. The solid, dry UO_2F_2 is converted to U_3O_8 by pyrohydrolysis. The U_3O_8 is dissolved in 2 N HNO_3 and filtered. The uranyl nitrate [$\text{UO}_2(\text{NO}_3)_2$] solution is adjusted to pH 1 with freshly prepared ammonium hydroxide (NH_4OH). Uranium peroxide ($\text{UO}_4 \cdot x\text{H}_2\text{O}$) is precipitated from the solution by the slow addition of hydrogen peroxide (H_2O_2) solution adjusted to pH 1 with HNO_3 . After settling, the precipitate is washed by decantation, filtered, washed, and ignited to U_3O_8 .

X2.3 Apparatus:

X2.3.1 *Electric Muffle Furnace*, 1000°C capability, equipped with automatic temperature controller and an inlet for a steam supply, to provide pyrohydrolysis conditions.

X2.3.2 *Nickel Cylinder*, 76 mm in diameter by 204 mm long, 3-mm wall thickness, equipped with two Monel or nickel-plated diaphragm-type valves.

X2.3.3 *Fluorothene Cylinder*, as shown in Fig. 4.

X2.3.4 *Critically Safe Container*, (Note X2.1), polyethylene, 127 mm in diameter and 1224 mm tall, with a polyethylene screw-type cap.

X2.3.5 *Platinum Dishes*, 200 to 300-mL capacity.

X2.3.6 *Büchner Funnel*, 127 mm in diameter.

X2.3.7 *Sieve*, constructed of acrylic plastic, with easily replaceable stainless steel screens.⁶

X2.3.8 *Mortar and Pestle*, boron carbide.

NOTE X2.1—While this procedure describes the preparation of oxide in batches of 200 g, some of the starting apparatus can easily handle larger quantities, which may be convenient for some laboratories.

X2.4 *Reagents*—Use only reagent grade chemicals and distilled water.

X2.5 Cleaning of Equipment:

X2.5.1 Wash the knockout cylinders with a 10 weight % sodium carbonate-5 volume % hydrogen peroxide solution, rinse thoroughly with tap water followed by distilled water, and dry at 110°C. Assemble the dry cylinder and treat with 1 atm of approximately 10 % fluorine in nitrogen at 110°C for 16 h. After cooling, evacuate the cylinder to remove the fluorine and close the valves while the cylinder is under vacuum. The cylinder is ready at this point to receive UF_6 .

X2.5.2 Wash the critically safe polyethylene containers with 8 N HNO_3 , rinse thoroughly with warm tap water, and rinse with distilled water.

X2.5.3 Clean polyethylene beakers, bottles, and vinyl tubing in the same manner as the polyethylene critically safe containers.

⁶ Similar to Spex Industries Stock No. 3540.

X2.5.4 Wash the Büchner funnel with 8 N HNO₃, rinse with hot tap water and with distilled water.

X2.5.5 Place the platinum dishes in 8 N HNO₃ and heat to boiling. Decant the acid and replace with fresh 8 N HNO₃ at least three times. Remove the platinum dishes and rinse with distilled water.

X2.5.6 Clean the body, cap, and pan of the sieve with 4 N HNO₃, rinse in warm tap water, followed by distilled water, drain, and dry at room temperature. Vapor degrease the stainless steel screen, clean with 4 N HNO₃, rinse with warm tap water followed by distilled water, and dry at 110°C.

X2.5.7 Wipe the boron carbide mortar and pestle clean with tissue, clean with 2 % (V/V) hydrochloric acid (HCl) in ethyl alcohol, rinse with distilled water, and dry at 110°C. Place a 10-g portion of the oxide to be ground in the mortar and grind with the pestle for 10 min. Repeat this cleaning and grinding procedure using a second 10-g portion of oxide. Discard both portions of oxide. Again, clean the mortar and pestle with 2 % HCl in ethyl alcohol, rinse with distilled water, and dry at 110°C.

X2.6 Procedure:

X2.6.1 Vapor Transfer and Hydrolysis of UF₆:

X2.6.1.1 Attach the nickel cylinder, containing the UF₆ which has been transferred from a larger supply, and also a clean and tared knockout cylinder to an appropriate vacuum manifold.

X2.6.1.2 Place a constant-temperature (50°C) water bath around the sample cylinder and an ice-and-water bath around the receiving knockout cylinder.

X2.6.1.3 After the cylinders have reached the temperatures of their baths, evacuate the connecting lines and receiving cylinder. Transfer the UF₆ vapor to the knockout cylinder but do not allow the pressure of the system to become greater than 250 millibars (1/3 atm.) absolute. Control the pressure in the system by adjusting the valve of the sample cylinder.

X2.6.1.4 When it is estimated that sufficient uranium has been transferred to the knockout cylinder, close the valves and remove the knockout cylinder from the manifold. (250 g of UF₆ is normally sufficient to prepare 200 g of U₃O₈.)

X2.6.1.5 Dry the knockout cylinder and weigh to determine the amount of UF₆ transferred. If additional UF₆ is needed, repeat X2.6.1.1-X2.6.1.5.

X2.6.1.6 Cool 1 to 2 L of distilled water to near-freezing for hydrolysis of 250 g of UF₆.

X2.6.1.7 Cool the nickel knockout cylinder in liquid nitrogen for 30 min. Remove the cap, invert the cylinder over the critically safe container, and rap the bottom of the cylinder sharply with a hammer or mallet until the solid UF₆ falls to the bottom of the container. Immediately add the chilled, distilled water to the container to hydrolyze the UF₆ to UO₂F₂.

X2.6.1.8 When the UF₆ has hydrolyzed and the solution has reached room temperature, fasten the cap securely, on the critically safe container, invert and roll the container until the UO₂F₂ solution is thoroughly mixed.

X2.6.2 Conversion of UO₂F₂ to U₃O₈:

X2.6.2.1 Transfer the UO₂F₂ solution to platinum dishes by siphoning directly into dishes or into an intermediate polyethylene beaker and then pouring into the dishes. The siphon can

be started by filling the tube with distilled water.

X2.6.2.2 Evaporate the solution in the platinum dishes to dryness under infrared heat lamps.

X2.6.2.3 Ignite the dried UO₂F₂ to U₃O₈ at 850°C for 3 h in a pyrohydrolysis furnace (pyrohydrolysis prevents volatilization of uranium and removes fluorides which interfere with subsequent precipitation of the uranium).

X2.6.3 Conversion of U₃O₈ to UO₂(NO₃)₂ with Nitric Acid:

X2.6.3.1 Weigh 200-g portions of the oxide into separate beakers (Note X2.2). Dissolve the U₃O₈ in a minimum amount of 2 N HNO₃; use heat to accelerate dissolution.

X2.6.3.2 Filter the UO₂(NO₃)₂ solution, using a fine-textured, low-ash, acid-washed filter paper. Collect the filtered solution in a 127-mm polyethylene critically safe container.

X2.6.3.3 When all of the material has been collected in the container, homogenize the solution by air agitation.

NOTE X2.2—The number of beakers permissible will depend on the ²³⁵U enrichment and on the nuclear safety requirement to limit the amount of material processed at any one time to 350 g of ²³⁵U.

X2.6.4 Uranium Peroxide Precipitation:

X2.6.4.1 Transfer portions of the UO₂(NO₃)₂ solution, containing about 150 to 175 g of uranium, to separate 4000-mL beakers. The volume of solution in each beaker should not exceed 2000 mL.

X2.6.4.2 Adjust the pH of the solutions to 1.0 on a pH meter, using freshly prepared ammonium hydroxide made by bubbling ammonia gas through distilled water. (Ammonium hydroxide prepared in this manner contains a minimum amount of silica.) Remove the electrodes from the solution when a pH of 1.0 is reached.

X2.6.4.3 Calculate the amount of peroxide required to precipitate the uranium, using the following equation: g U × 1.3 = mL of 30 % reagent hydrogen peroxide.

X2.6.4.4 Dilute the calculated amount of reagent peroxide with four times its volume of nitric acid solution at a pH of 1.0. Readjust the acidity to a pH of 1. (The purpose of this dilution is to avoid a localized precipitation of the UO₄·2H₂O.)

X2.6.4.5 Add the diluted hydrogen peroxide slowly to the uranium solution while mixing with a motor-driven glass stirring rod.

X2.6.4.6 After 30 min stirring, adjust the pH of the solution again to 1.0, using ammonium hydroxide prepared as in X2.6.4.2. (The formation of UO₄·2H₂O from UO₂(NO₃)₂ and H₂O₂ results in an increase in acidity.) Remove the stirrer and allow the UO₄·2H₂O to settle for at least 16 h. Keep the solution covered during this time.

X2.6.4.7 Decant the supernatant solution. Wash the precipitate with two 1000-mL portions of 1 % H₂O₂ in HNO₃ at a pH of 1.0, allowing the precipitate to settle between washes and decanting the supernatant solution. Vacuum-filter the precipitate, using a 127-mm Büchner funnel and fine-textured, low-ash, acid-washed filter paper.

X2.6.4.8 When the uranium precipitate from a single beaker is on the filter paper, wash three times by covering the filter cake with a solution of 1 % H₂O₂ in HNO₃ at a pH of 1.0. Do not continue suction after the cake becomes dry, since this practice may introduce airborne impurities, unless the funnel is covered with a filter paper held tightly with rubber bands.

X2.6.5 Conversion to U_3O_8 , Sieving, and Final Ignition:

X2.6.5.1 Dry the filter cake in the funnel under an infrared lamp until the precipitate can be easily separated from the paper and transferred to a weighed platinum dish. (To minimize the presence of carbon in the uranium oxide, do not ignite the filter paper.)

X2.6.5.2 Ignite the $UO_4 \cdot 2H_2O$ to U_3O_8 at $900^\circ C$ for 4 h. Weigh to determine the amount of U_3O_8 .

X2.6.5.3 Sieve the oxide in small lots, using the acrylic plastic sieve with stainless steel screen. (In the absence of any other sieve-size requirement, general needs for handling and blending are met by passage through a 60-mesh screen.) The oxide which passes through the sieve is placed into a blending jar (less than 127 mm in diameter).

X2.6.5.4 Grind the oxide that does not pass the screen with

a boron carbide mortar and pestle until it passes the screen.

X2.6.5.5 Reignite the U_3O_8 at $900^\circ C$ for 16 h.

X2.6.6 *Blending and Sampling*—Blend the oxide to assure homogeneous composition and representatively sample the batch for spectrochemical and chemical analysis, to assure high purity.

X2.7 *Purity*—The chemical purity of U_3O_8 properly prepared by the prescribed procedure will be 99.995 weight % or better. The combined impurities, detected by spectrographic analysis for 61 metallic elements and chemical analysis for carbon, sulfur, and phosphorus, in several final oxide supplies prepared in kilogram quantities, ranged from 10 to 40 ppm (uranium basis).

X3. PREPARATION AND PACKAGING WRM

X3.1 The following examples of procedures illustrate the preparation and packaging of two WRMs, one starting with plant material and the other starting with metal. The plant material is plutonium nitrate solution and the metal is high purity uranium metal.

X3.2 *Preparation from Plant Material*⁷—A plant plutonium nitrate solution selected as the starting material for a WRM shall have measured and representative impurity levels and isotopic abundance values. Also, the selected material must be single phase and have no heterogeneously distributed organic matter. This procedure provides treatment designed to destroy plutonium polymers. In this procedure and subsequent treatments to produce the WRM, dilution relative to the plutonium concentration of the plant material occurs. The plant material, therefore, should be selected or should be concentrated by low-temperature evaporation to contain 1.5 times the normal plutonium concentration of the plant stream.

X3.2.1 Reagents:

X3.2.1.1 HF , 29M, and

X3.2.1.2 HNO_3 , 15.7M, 8M, and 2M.

X3.2.2 Apparatus:

X3.2.2.1 *Beaker*, appropriate size for the volume of WRM to be prepared, with unribbed watch glass as a cover.

X3.2.2.2 *Hot plate*.

X3.2.3 Procedure:

X3.2.3.1 Transfer a desired volume of the selected plant plutonium nitrate solution to a beaker having a capacity at least four times the volume attained in X3.2.3.2.

X3.2.3.2 Adjust the HNO_3 concentration to 8M by adding an amount of 15.7M HNO_3 or 2M HNO_3 calculated based on the HNO_3 concentration of the plant plutonium nitrate solution. Do not use water as a diluent because localized concentrations of low acidity in solution may cause hydrolysis of the plutonium and formation of an insoluble hydrous oxide.

X3.2.3.3 Add a calculated volume of 29M HF to produce a solution that is 0.05M in HF .

X3.2.3.4 Heat the solution at 80 to $90^\circ C$ for at least 2 h at a moderate rate so that no solution is sprayed onto the beaker walls.

X3.2.3.5 Allow the solution to age for about two weeks. Cover the beaker with a cover glass to decrease evaporation. See Note X3.1.

X3.2.3.6 Filter the aged solution, collecting the filtrate in a tared volumetric flask. Rinse the filter with 8M HNO_3 . See Note X3.2.

X3.2.3.7 Dilute to volume to give a final acid concentration of about 8M, using 15.7M HNO_3 to increase acidity or not less than 2M to decrease acidity.

X3.2.3.8 Stopper the flask and weigh.

X3.2.3.9 Mix the solution by inverting the flask at least 10 times or mix using a TFE-fluorocarbon coated magnetic stir bar for at least 5 min.

X3.2.3.10 Package the WRM. See X3.3.

NOTE X3.1—All plutonium nitrate WRMs prepared for plutonium concentration measurements, except those prepared by dissolving plutonium metal in HCl , are aged to provide time for radiolytically generated hydrogen peroxide to reduce any Pu(VI) to Pu(IV). Two weeks ensure that >99 % of the plutonium is Pu(IV). Because the reduction of Pu(VI) by hydrogen peroxide produces gas, the solution is open to the atmosphere during the aging period. The aging period also provides a reasonable time for precipitate formation, an undesirable effect often occurring in plutonium nitrate solutions.

NOTE X3.2—Every plutonium nitrate WRM intended for use in plutonium concentration measurements is filtered, even when no precipitate is apparent. The recommended filter is a plastic membrane-type, resistant to 8M HNO_3 , with a 0.45- μm pore size. The filter, with residue, is analyzed for its plutonium content, and the assay value of the WRM either is corrected for the insoluble plutonium or the WRM is characterized for its plutonium concentration using two different assay methods.

X3.3 *Packaging Solution in Glass Ampoules*—The containers are flame-sealed, thick-walled glass ampoules designed for 10 mL or less of solution. Normally, the packaging is for WRMs used for plutonium concentration. If the packaging is to be for total plutonium content per ampoule, the ampoules must

⁷ Based on NUREG-0118 (also designated LA-NUREG-6348), Preparation of Working Calibration and Test Materials: Plutonium Nitrate Solution, Nuclear Regulatory Commission. Available from the Superintendent of Documents, U.S. Government Printing Office, Washington, DC 20402.

be weighed (tared) before transfer of the WRM and weighed after transfer (see X3.3.1.3).

X3.3.1 Filling Ampoules:

X3.3.1.1 Clean, dry, and label the ampoules.

X3.3.1.2 Insert the buret (see Fig. 5) into an ampoule, being careful not to let the tip of the buret touch the inside wall of the ampoule.

X3.3.1.3 Transfer the desired amount of WRM solution to the ampoule, then temporarily seal the ampoule with a rubber stopper.

X3.3.1.4 Repeat X3.3.1.2 and X3.3.1.3 until all ampoules are filled.

X3.3.2 Sealing Ampoules:

X3.3.2.1 Within 1 h of filling, flame seal each ampoule's neck about 70 mm above the body, using an oxygen-gas flame. Complete the seal in less than 1 min to avoid warming the solution.

X3.3.2.2 Anneal in an air-gas flame and allow to cool. See Note X3.3.

X3.3.2.3 Test the integrity of the seals by inverting each ampoule, smearing the seal with a filter paper, and alpha counting the paper. Reject any leaky ampoule.

NOTE X3.3—The sealing and annealing should be done by an experienced glassblower.

X3.4 Preparation from Uranium Metal⁸—Clean high purity uranium metal of any surface oxide and weigh. Dissolve the metal and dilute the resulting solution to volume to give the desired uranium concentration. Measure the mass of the solution and calculate the uranium concentration (g U/g soln). Dispense weighed aliquants of the solution into individual containers for use as measurement standards.

X3.4.1 Reagents:

X3.4.1.1 HNO_3 , 8M, and

X3.4.1.2 Uranium Metal, 99.9 %.

X3.4.2 Apparatus:

X3.4.2.1 Glass Bottles, 500 mL, equipped with polycone seal caps.

X3.4.2.2 Glass Flask, 5 L.

X3.4.2.3 Polyethylene Dispensing Bottles, 60 mL and 125 mL.

X3.4.2.4 Titration Beakers.

X3.4.2.5 Petri Dish, for each beaker.

X3.4.3 Preparation and Storage of Master Solution:

X3.4.3.1 Clean about 65 g of metal in 8M HNO_3 . Rinse thoroughly with distilled water and then with acetone. Dry with a lint-free towel and weigh to the nearest 0.01 mg. Calculate the actual mass of uranium by applying the proper buoyancy and purity corrections. See Note X3.4.

X3.4.3.2 Transfer the metal carefully to a preweighed 5-L glass flask. Add 150 mL of 8M HNO_3 and warm the flask over low heat. Replenish the acid as needed until dissolution is completed. Record the total amount of acid added.

X3.4.3.3 Cool the solution to ambient temperature and bring to a total volume of 4 L by adding distilled water in 300 to 500-mL portions and swirling after each addition. See Note X3.5.

X3.4.3.4 Transfer the solution to 500-mL glass bottles, filling only to the shoulders of the bottles. Wipe the mouth of each bottle before adding and tightening the cap. Weigh each bottle to the nearest 0.01 g and seal with plastic tape. The master solution is stored in these bottles.

X3.4.3.5 Check the weight whenever a bottle is opened for the first time. Do not use the solution in a bottle if a discrepancy in the weights of greater than 0.1 g is observed. See Note X3.6.

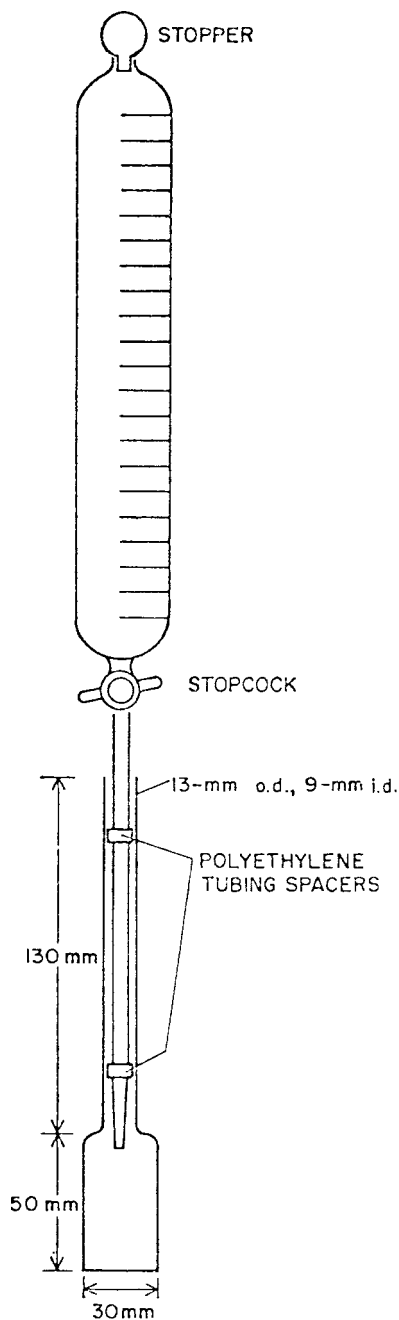

FIG. 5 Apparatus for Filling Ampoules

⁸ Based on NBL-CAL-U(E)-2, Preparation of Uranium Standard Solution from Uranium Metal, New Brunswick Laboratory, United States Department of Energy. Available from the Superintendent of Documents, U.S. Government Printing Office, Washington, DC 20402.

NOTE X3.4—The uranium metal buoyancy correction (assuming a uranium metal density of 18.7) for balance weights with an apparent density of 8.0 g per cm is -0.086 mg per g (at sea level) or -0.082 (at 740 mm Hg, 25°C, and 30 % relative humidity).

NOTE X3.5—The final uranium concentration should be about 15 mg U per g solution.

NOTE X3.6—Data accumulated from several master solutions have shown that, with proper care in handling, these solutions can be stored for periods in excess of one year.

X3.4.4 Preparation of Measurement Standards:

X3.4.4.1 Transfer about 125 g of master solution to a 125 mL polyethylene dispensing bottle or 60 g to a 60 mL bottle. Weigh the bottle to the nearest 0.01 mg.

X3.4.4.2 Dispense a selected amount of the master solution into an appropriately identified titration beaker. Reweigh the bottle and record the weight.

X3.4.4.3 Continue X3.4.4.2 until the dispensing bottle is empty.

X3.4.4.4 Rinse the walls of each beaker with distilled water and then evaporate the solution in each beaker to dryness on a steam bath. Cool and cover each beaker with a petri dish.

X3.4.4.5 Store the beakers until a measurement standard is needed. Then, dissolve the dried contents of a beaker.

ASTM International takes no position respecting the validity of any patent rights asserted in connection with any item mentioned in this standard. Users of this standard are expressly advised that determination of the validity of any such patent rights, and the risk of infringement of such rights, are entirely their own responsibility.

This standard is subject to revision at any time by the responsible technical committee and must be reviewed every five years and if not revised, either reapproved or withdrawn. Your comments are invited either for revision of this standard or for additional standards and should be addressed to ASTM International Headquarters. Your comments will receive careful consideration at a meeting of the responsible technical committee, which you may attend. If you feel that your comments have not received a fair hearing you should make your views known to the ASTM Committee on Standards, at the address shown below.

This standard is copyrighted by ASTM International, 100 Barr Harbor Drive, PO Box C700, West Conshohocken, PA 19428-2959, United States. Individual reprints (single or multiple copies) of this standard may be obtained by contacting ASTM at the above address or at 610-832-9585 (phone), 610-832-9555 (fax), or service@astm.org (e-mail); or through the ASTM website (www.astm.org).