



# Standard Practice for Preparation and Dissolution of Plutonium Materials for Analysis<sup>1</sup>

This standard is issued under the fixed designation C 1168; the number immediately following the designation indicates the year of original adoption or, in the case of revision, the year of last revision. A number in parentheses indicates the year of last reapproval. A superscript epsilon ( $\epsilon$ ) indicates an editorial change since the last revision or reapproval.

<sup>ε1</sup> NOTE—Keywords were added editorially in August 1995.

## 1. Scope

1.1 This practice is a compilation of dissolution techniques for plutonium materials that are applicable to the test methods used for characterizing these materials. Dissolution treatments for the major plutonium materials assayed for plutonium or analyzed for other components are listed. Aliquants of the dissolved samples are dispensed on a weight basis when one of the analyses must be highly reliable, such as plutonium assay; otherwise they are dispensed on a volume basis.

1.2 The treatments, in order of presentation, are as follows:

Procedure Title	Section
Dissolution of Plutonium Metal with Hydrochloric Acid	7.1
Dissolution of Plutonium Metal with Sulfuric Acid	7.2
Dissolution of Plutonium Oxide and Uranium-Plutonium Mixed Oxide by the Sealed-Reflux Technique	7.3
Dissolution of Plutonium Oxide and Uranium-Plutonium Mixed Oxides by Sodium Bisulfate Fusion	7.4
Dissolution of Uranium-Plutonium Mixed Oxides and Low-Fired Plutonium Oxide in Beakers	7.5

1.3 The values stated in SI units are to be regarded as standard.

1.4 *This standard does not purport to address all of the safety concerns, if any, associated with its use. It is the responsibility of the user of this standard to establish appropriate safety and health practices and determine the applicability of regulatory limitations prior to use.*

## 2. Referenced Documents

### 2.1 ASTM Standards:

- C 757 Specification for Nuclear-Grade Plutonium Dioxide Powder, Sinterable<sup>2</sup>
- C 833 Specification for Sintered (Uranium-Plutonium) Dioxide Pellets<sup>2</sup>
- C 1008 Specification for Sintered (Uranium-Plutonium) Dioxide Pellets—Fast Reactor Fuel<sup>2</sup>

## 3. Summary of Dissolution Methods

3.1 Most plutonium-containing samples are dissolved with

various mineral acids and, except for plutonium metal, with applied heat. Dissolution-resistant materials are dissolved in heated and sealed containers in which pressurization provides a higher temperature than is attained at ambient pressure.

3.2 Another dissolution technique is fusion of refractory plutonium oxide with sodium bisulfate.

3.3 The dissolved materials are quantitatively transferred to a tared polyethylene dispensing bottle for subsequent deliveries of weight aliquants for high-precision analysis methods, such as assays, or to a volumetric flask for deliveries of volume aliquants for less precise analysis methods, such as impurity analyses. Acids, usually 1 *M*, are used as rinses to effect quantitative transfers and as diluents in the polyethylene dispensing bottles and volumetric flasks. The use of water for these purposes can, in some cases, result in hydrolysis of plutonium to produce polymers that, although soluble, are nonreactive in separation treatments or in plutonium assay methods that have no pretreatments, such as fuming with acid.

3.4 Plutonium metal is dissolved with hydrochloric acid or with sulfuric acid.

3.5 Plutonium oxide, calcined at about 1000°C or lower, is dissolved with a mixture of hydrochloric, nitric, and hydrofluoric acids using the sealed-reflux techniques **(1)**.<sup>3</sup> More refractory plutonium oxide is dissolved with a fusion using sodium bisulfate **(2)**. Low-fired (<650°C) plutonium oxide can also be dissolved in a mixture of nitric and hydrofluoric acids in beakers.

3.6 Uranium-plutonium mixed oxide is dissolved in either of three ways: sodium bisulfate fusion, a heated mixture of nitric and hydrofluoric acids in a beaker, or a mixture of hydrochloric, nitric, and hydrofluoric acids by the sealed-reflux technique.

3.7 Combinations of these dissolution techniques described in 3.4 to 3.6 are sometimes used on difficult-to-dissolve samples.

3.8 Quantitative transfers of samples and subsequent solution are required. Whenever a loss is incurred or even suspected, the sample is rejected. Solutions of dissolved samples are inspected for undissolved particles; if particles are present,

<sup>1</sup> This practice is under the jurisdiction of ASTM Committee C-26 on Nuclear Fuel Cycle and is the direct responsibility of Subcommittee C26.05 on Methods of Test.

Current edition approved Nov. 30, 1990. Published March 1991.

<sup>2</sup> Annual Book of ASTM Standards, Vol 12.01.

<sup>3</sup> The boldface numbers in parentheses refer to a list of references at the end of this practice.

further treatment is necessary to attain complete solubility. When analyzing the dissolved sample for trace impurities, caution should be exercised so the dissolution process does not cause the impurity to be lost or does not significantly increase the level of impurity being determined.

#### 4. Significance and Use

4.1 The materials covered are plutonium metal, plutonium oxide, and uranium-plutonium mixed oxide, that must meet ASTM specifications.

4.2 Plutonium and uranium mixtures are used as nuclear reactor fuels. For use as a nuclear reactor fuel, the material must meet certain criteria for combined uranium and plutonium content, effective fissile content, and impurity content as described in Specifications C 757, C 833, and C 1008. The material is assayed for plutonium and uranium to determine if the content is correct as specified by the purchaser.

4.3 The materials not covered are unique plutonium materials, including alloys, compounds, and scrap materials. The user must determine the applicability of this practice to these other materials. In general, these unique plutonium materials are dissolved with various acid mixtures or by fusion with various fluxes. Many plutonium salts are soluble in hydrochloric acid.

#### 5. Apparatus

5.1 *Balances*, for weighing samples and solutions. A balance with a sensitivity of 0.1 mg is necessary; however, a balance with 0.01 mg sensitivity is more desirable. A calibrated balance must be used.

5.2 *Beakers, Test Tubes, and Erlenmeyer Flasks*—Generally, borosilicate glass is recommended; however, the analyst should be sure that safety and sample contamination from the container are considered when choosing appropriate containers.

5.3 *Furnace*, with controller for timed operation. The furnace must be capable of maintaining an even temperature of  $\pm 10^\circ\text{C}$  up to  $700^\circ\text{C}$ .

5.4 *Heating Equipment*—Hot plates and infrared lamps are used.

5.5 *Inert Atmosphere Glove-Box System*—capability of maintaining less than 10 ppm of  $\text{H}_2\text{O}$  and of  $\text{O}_2$  is preferred.

5.6 *Sealed-Reflux Dissolution Apparatus*—The example apparatus is shown in Fig. 1 and Fig. 2 and is further described in Ref (1).

#### 6. Reagents

NOTE 1—Use distilled or demineralized water for all reagents.

6.1 *Hydrochloric Acid* (sp gr 1.18), 12 M.

6.2 *Hydrochloric Acid*, 6 M—Add 500 mL of 12 M HCl to <500 mL of water and dilute to 1 L with water.

6.3 *Hydrochloric Acid*, 1 M—Add 83 mL of 12 M HCl to <900 mL of water and dilute to 1 L with water.

6.4 *Hydrofluoric Acid* (sp gr 1.17), 28 M.

6.5 *Hydrofluoric Acid*, 1.3 M—Transfer 4.8 mL of 28 M HF, using a plastic pipet, to a 100-mL plastic graduated cylinder containing <90 mL of water and dilute to 100 mL with water. Transfer to a plastic bottle for storage.

6.6 *Hydrofluoric Acid-Nitric Acid Mixture*, 0.05 M HF-16 M  $\text{HNO}_3$ —Add 1.8 mL 28 M HF, using a plastic pipet, to 1 L of 16 M  $\text{HNO}_3$ .

6.7 *Nitric Acid* (sp gr 1.42), 16 M.

6.8 *Nitric Acid*, 1 M—Add 62 mL of 16 M  $\text{HNO}_3$  to <900 mL of water and dilute to 1 L with water.

6.9 *Sodium Bisulfate, Anhydrous, Fused,  $\text{NaHSO}_4$* —Grind the sodium bisulfate just before use, if necessary.

6.10 *Sulfuric Acid* (sp gr 1.84), 18 M.

6.11 *Sulfuric Acid*, 0.5 M—Cautiously add 28 mL of 18 M  $\text{H}_2\text{SO}_4$  to water and dilute to 1 L with water.

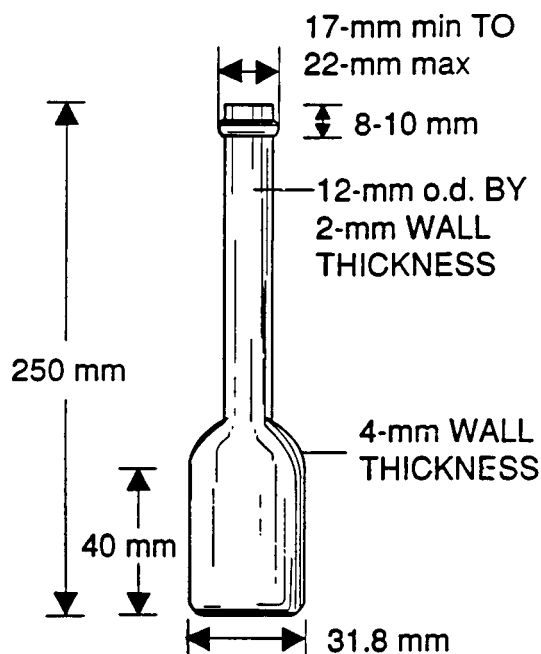

FIG. 1 Sealed-Reflux Dissolution Tube

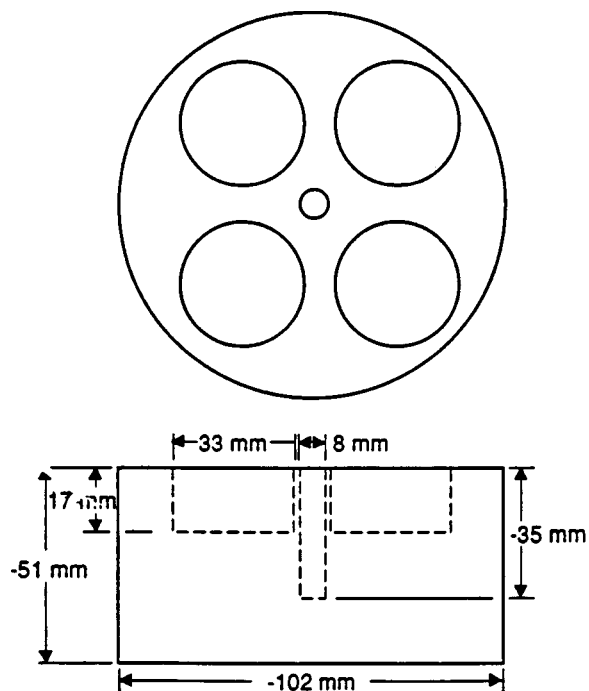

FIG. 2 Heating Block

## 7. Procedures

### 7.1 Procedure 1—Dissolution of Plutonium Metal with Hydrochloric Acid:

7.1.1 Remove surface oxide, if present, from the bulk sample before cutting into portions. This procedure can be done either by filing the plutonium metal in an inert atmosphere or by using other mechanical or chemical means.

NOTE 2—Plutonium metal reacts with air and moisture to form PuO<sub>2</sub>, so it is recommended that it be cleaned and weighed in an inert-atmosphere glove box.

7.1.2 Weigh a representative sample size, considering the required precision and the analysis method to be used. Normal sample size is 50 to 700 mg, but this may vary.

7.1.3 Transfer the weighed sample to a beaker or centrifuge tube and cover with a watch glass.

7.1.4 Cautiously add 6 M HCl dropwise through the spout of the beaker or centrifuge tube until the sample dissolves completely.

7.1.5 Inspect the solution for suspended particles or deposited solid and, if present, warm the solution.

7.1.6 If solid still is present, add 0.5 mL 16 M HNO<sub>3</sub> and three drops 1.3 M HF, and heat.

7.1.7 Quantitatively transfer the solution to a previously tared polyethylene dispensing bottle and weigh the solution or transfer to a volumetric flask, using at least four rinses of the watch glass and beaker or centrifuge tube with 1 M HCl.

7.1.8 Mix the solution well, equilibrate to room temperature, and dispense aliquants for analysis.

### 7.2 Procedure 2—Dissolution of Plutonium Metal with Sulfuric Acid:

7.2.1 If present, remove surface oxide from the bulk sample before cutting into portions by filing the plutonium metal in an inert atmosphere or by using other mechanical or chemical means.

NOTE 3—Plutonium metal reacts with air and moisture to form PuO<sub>2</sub>, so it is recommended that it be cleaned and weighed in an inert-atmosphere glove box.

7.2.2 Weigh a representative sample size, considering the required precision and the analysis method to be used. Normal sample size is 50 to 700 mg, but this may vary.

7.2.3 Transfer the weighed sample to a beaker or Erlenmeyer flask and cover with a watch glass.

7.2.4 Carefully place a TFE-fluorocarbon stirring bar in the beaker or flask along with 30 to 40 mL of 0.5 M sulfuric acid, put the dissolution container on a magnetic stirrer, and mix the solution until the sample is dissolved.

7.2.5 Inspect the solution for suspended particles or deposited solid and, if present, warm the solution.

7.2.6 Quantitatively transfer the solution to a previously tared polyethylene dispensing bottle and weigh the solution or transfer to a volumetric flask, using at least four rinses of the watch glass and beaker or Erlenmeyer flask with 0.5 M sulfuric acid.

7.2.7 Mix the solution well, equilibrate to room temperature, and dispense aliquants for analysis.

### 7.3 Procedure 3—Dissolution of Plutonium Oxide and

### Uranium-Plutonium Mixed Oxide by the Sealed-Reflux Technique:

7.3.1 Tare a weighing pan or other type of container.

7.3.2 Transfer sample to the tared pan or other container until the desired weight of sample is obtained, usually 0.5 g. Weigh to at least 0.1 mg sensitivity.

7.3.3 Quantitatively transfer the sample from the pan into a sealed-reflux tube, see Fig. 1.

7.3.4 Reweigh the pan. Compute the weight of sample transferred to the tube by subtracting the weight of the pan from the weight of the sample plus the pan.

7.3.5 Add 5 mL of 12 M HCl, 3 drops 16 M HNO<sub>3</sub>, and 3 drops 1.3 M HF to the tube.

NOTE 4—Other acid combinations containing nitric or sulfuric acid as the major constituent that can be used are described in Ref (1).

7.3.6 Seal the tube with a stopper, clamp, and heat at 150°C in a heating block (see Fig. 2) for 2 h or until the sample dissolves completely. Cool the tube to <30°C before releasing the clamp.

7.3.7 Quantitatively transfer the solution to a previously tared polyethylene dispensing bottle and weigh the solution or transfer to a volumetric flask, using at least four rinses of the tube with 1 M HCl.

7.3.8 Mix the solution well, equilibrate to room temperature, and dispense aliquants for analysis.

### 7.4 Procedure 4—Dissolution of Plutonium Oxide and Uranium-Plutonium Mixed Oxides by Sodium Bisulfate Fusion:

NOTE 5—This dissolution method is not recommended for use with trace-impurity analysis methods because of the possibility of contaminating the sample with impurities from the flux or beaker, or both.

7.4.1 Quantitatively transfer a 100 to 300-mg sample of plutonium oxide or 1 to 1.5 g of pulverized uranium-plutonium mixed oxide to a beaker or Erlenmeyer flask. A fused silica container is recommended to reduce sample contamination. The sample should be weighed to at least ±0.1 mg.

NOTE 6—Because of the recommended temperature, fused silica or 96 % silica are the container materials of choice; however, experience has shown that borosilicate glass can be used.

7.4.2 Add ten times the sample weight of anhydrous fused NaHSO<sub>4</sub> and carefully swirl the beaker to mix the powders.

7.4.3 Cover the beaker with a watch glass and place it in a cold furnace.

7.4.4 Slowly heat to 600 to 625°C to prevent sample spatter or temperature overshoot, or both, hold at 600 to 625°C for 20 to 30 min.

NOTE 7—**Caution:** Do not exceed 600 to 625°C or the 30 min time limit because an insoluble component may form.

7.4.5 After cooling at room temperature for at least 30 min, add 30 to 40 mL of 0.5 M H<sub>2</sub>SO<sub>4</sub> or of water.

NOTE 8—Experience has shown that in this acid bisulfate medium, water can be used to dissolve the salt when maximum acid strength and sample volume cannot be exceeded. The solution should be mixed immediately after the water is added.

7.4.6 Quantitatively transfer the solution to a previously tared polyethylene dispensing bottle and weigh the solution or

transfer to a volumetric flask, using at least four rinses of the beaker and watch glass with 0.5 M H<sub>2</sub>SO<sub>4</sub>.

7.4.7 Mix the solution well, equilibrate to room temperature, and dispense aliquants for analysis.

7.5 *Procedure 5—Dissolution of Uranium-Plutonium Mixed Oxides and Low-Fired (<650°C) Plutonium Oxide in Beakers:*

7.5.1 Quantitatively transfer a sample of up to 1 g that is weighed to at least ±0.1 mg into a beaker.

7.5.2 Add 10 to 50 mL of 0.05 M HF–16 M HNO<sub>3</sub> mixture, cover with a watch glass, and heat until the sample dissolves completely.

NOTE 9—Experience has shown that a HNO<sub>3</sub> concentration in this acid mixture of 8 M or greater is adequate.

7.5.3 Quantitatively transfer the solution to a previously tared polyethylene dispensing bottle and weigh the solution or transfer to a volumetric flask, using at least four rinses of the beaker and watch glass with 1 M HNO<sub>3</sub>.

7.5.4 Mix the solution well, equilibrate to room temperature, and dispense aliquants for analysis.

## 8. Reliability

8.1 The objectives of a dissolution treatment are complete solubility, absence of plutonium polymers, and complete recovery in all operations. Careful laboratory practices are required in all operations.

8.2 For optimum reliability, every dissolved sample solution must be carefully inspected for solids deposited on the con-

tainer bottom and in suspension. The observation of suspended particles is enhanced by shining a light beam into the solution from the side and looking down on the solution. Alternatively, the solution can be centrifuged to concentrate the residue.

8.3 If a residue remains after any of the dissolution procedures, whether this residue is one of the constituents to be measured must be determined. If so, it must be put into solution through further treatments, which are at the discretion of the analyst, and added to the original solution, or the solutions may be analyzed separately.

8.4 If, after multiple treatments to dissolve residues, solids still persist, the originator of the sample should be consulted concerning whether further treatment is required to effect complete solubility. Alternatively, a nondestructive analysis can be done on the residue to determine if any component being tested for is still present in the residue. Also, other dissolution treatments described in Refs (2, 3, 4, 5, 6, 7) can be applied.

## 9. Precision and Bias

9.1 This is not a test method and no data is generated by this practice, so a precision and bias statement is not required.

## 10. Keywords

10.1 compilation of dissolution techniques; plutonium analysis preparation; plutonium dissolution; plutonium metal dissolution; plutonium oxide dissolution; uranium-plutonium mixed oxide dissolution

## REFERENCES

- (1) Dahlby, J. W., Geoffrion, R. R., and Waterbury, G. R. "The Sealed-Reflux Dissolution System", Los Alamos Scientific Laboratory Report LA-5776, 1975.
- (2) Petri, C.E., "Preparation and Dissolution of Plutonium Samples in The Nuclear Fuel Cycle", New Brunswick Laboratory Report NBL-258, pp. 36–41.
- (3) Metz, C. F., and Waterbury, G. R., "Sealed-Tube Dissolution Method with Application to Plutonium-Containing Materials", Los Alamos Scientific Laboratory Report LA-3554, 1966.
- (4) Gilman, W. S., "A Review of the Dissolution of Plutonium Dioxide", Mound Laboratory Report MLM-1264, 1965.
- (5) Black, R. M., and Drummond, J. L., "A Comparison of Procedures for Dissolving Ignited Plutonium Oxides for Analysis", TRG Report 1072(D), 1965.
- (6) Deaton, R. L., and Silver, G. L., "Dissolution of Plutonium Dioxide", *Radiochemical and Radioanalytical Letters* 10(5) pp. 277–283, 1972.
- (7) Woltermann, H. A., and Ulrick, T. L., "Dissolution of High-Fired Plutonium Oxide", Mound Laboratory Report MLM-2010, 1973.

*The American Society for Testing and Materials takes no position respecting the validity of any patent rights asserted in connection with any item mentioned in this standard. Users of this standard are expressly advised that determination of the validity of any such patent rights, and the risk of infringement of such rights, are entirely their own responsibility.*

*This standard is subject to revision at any time by the responsible technical committee and must be reviewed every five years and if not revised, either reapproved or withdrawn. Your comments are invited either for revision of this standard or for additional standards and should be addressed to ASTM Headquarters. Your comments will receive careful consideration at a meeting of the responsible technical committee, which you may attend. If you feel that your comments have not received a fair hearing you should make your views known to the ASTM Committee on Standards, 100 Barr Harbor Drive, West Conshohocken, PA 19428.*