

This document is not an ASTM standard and is intended only to provide the user of an ASTM standard an indication of what changes have been made to the previous version. Because it may not be technically possible to adequately depict all changes accurately, ASTM recommends that users consult prior editions as appropriate. In all cases only the current version of the standard as published by ASTM is to be considered the official document.



---

**Designation: C 1206 – 91 (Reapproved 1996)**

**Designation: C 1206 – 02**

# Standard Test Method for Plutonium by Iron (II)/Chromium (VI) Amperometric Titration<sup>1</sup>

This standard is issued under the fixed designation C 1206; the number immediately following the designation indicates the year of original adoption or, in the case of revision, the year of last revision. A number in parentheses indicates the year of last reapproval. A superscript epsilon (ε) indicates an editorial change since the last revision or reapproval.

<sup>1</sup> This test method is under the jurisdiction of ASTM Committee C-26 on Nuclear Fuel Cycle and is the direct responsibility of Subcommittee C26.05 on Methods of Test. Current edition approved Nov. 15, 1991; Jan. 10, 2002. Published June 1992; April 2002. Originally published as C 1206-91. Last previous edition C 1206-91(1996).

## 1. Scope

1.1 This test method covers the determination of plutonium in unirradiated nuclear-grade plutonium dioxide, uranium-plutonium mixed oxides with uranium (U)/plutonium (Pu) ratios up to 21, plutonium metal, and plutonium nitrate solutions. Optimum quantities of plutonium to measure are 7 to 15 mg.

1.2 *This standard does not purport to address all of the safety concerns, if any, associated with its use. It is the responsibility of the user of this standard to establish appropriate safety and health practices and determine the applicability of regulatory limitations prior to use.*

## 2. Referenced Documents

### 2.1 ASTM Standards:

~~C 697 Test Methods 1168 Practice for Chemical, Mass Spectrometric, and Spectrochemical Analysis of Nuclear-Grade Plutonium Dioxide Powders and Pellets<sup>2</sup>~~

~~C 698 Test Methods for Chemical, Mass Spectrometric, and Spectrochemical Analysis of Nuclear-Grade Mixed Oxides ((U, Pu)O<sub>2</sub>)<sup>2</sup>~~

~~C 757 Specification for Nuclear-Grade Plutonium Dioxide Powder, Sinterable<sup>2</sup>~~

~~C 758 Test Methods for Chemical, Mass Spectrometric, Spectrochemical, Nuclear, and Radiochemical Analysis of Nuclear-Grade Plutonium Metal<sup>2</sup>~~

~~C 759 Test Methods for Chemical, Mass Spectrometric, Spectrochemical, Nuclear, and Radiochemical Analysis of Nuclear-Grade Plutonium Nitrate Solutions<sup>2</sup>~~

~~C 833 Specification for Sintered (Uranium-Plutonium) Dioxide Pellets<sup>2</sup>~~

~~C 1168 Practice for Preparation and Dissolution of Plutonium Materials for Analysis<sup>2</sup>~~

<sup>2</sup> Annual Book of ASTM Standards, Vol 12.01.

### 3. Committee C-26 Safeguards Statement

3.1 The materials [nuclear-grade mixed oxides (U, Pu)O<sub>2</sub> powders, pellets, Pu metal, Pu oxides, and Pu nitrates] to which this test method applies, are subject to nuclear safeguards regulations governing their possession and use. This analytical test method has been designated as technically acceptable for generating safeguards accountability measurement data for plutonium.

3.2 When used in conjunction with appropriate standard reference material this test method can demonstrate traceability to the national measurement base. However, adherence to this test method does not automatically guarantee regulatory acceptance of the resulting safeguards measurements. It remains the sole responsibility of the user of this test method to ensure that its application to safeguards has the approval of the proper regulatory authorities.

### 4. Summary of Test Method

4.1 Amperometric titrations are based on the measured change in the current flow between two electrodes, held at constant potential, when a titrant is added. The plutonium is first oxidized to the +6 oxidation state in a dilute sulfuric acid solution with argentic oxide. The excess oxidant is destroyed by heating, and the Pu(VI) is then reduced to Pu(IV) by excess Fe(II) during the titration. The excess Fe(II) is titrated by Cr(VI), and the Pu determined by difference from the quantities of the two titrants.

4.2 Oxide and metal samples are prepared to produce final solutions as a soluble sulfate. Plutonium-nitrate solutions can be introduced directly at the beginning of the procedure and are later diluted with sulfuric acid. Chlorides must be removed.

### 5. Significance and Use

5.1 All plutonium materials covered in this test method are used in the preparation of nuclear-reactor fuels. In order to be suitable for this purpose, the materials must meet specified criteria for plutonium content. This test method is used to verify the plutonium content.

5.2 A primary standard dichromate such as that available from National Institute of Standards and Technology (NIST) or a dichromate traceable to a primary standard such as a National Institute of Standards and Technology (NIST) New Brunswick Laboratory (NBL) plutonium standard, is required for this technique.

### 6. Interferences

6.1 Interference is caused by ions that are oxidized by argentic oxide and reduced by ferrous ion in sulfuric-acid solution. Elements that may be present in plutonium materials and that will produce quantitative positive errors include vanadium (V), chromium (Cr), and manganese (Mn). Correction can be made for these elements by calculation when they do not individually exceed 200 µg impurity elements per gram of plutonium.

6.2 Other elements that will cause positive errors include cerium (Ce), ruthenium (Ru), gold (Au), rhodium (Rh), platinum (Pt), lead (Pb), and neptunium (Np). Americium (Am) does not interfere because it is not oxidized to higher valency states during the argentic oxidation.

6.3 Thallium (Tl), selenium (Se), calcium (Ca), and barium (Ba) give low results.

### 7. Apparatus

7.1 *Weighing Burets*, polyethylene drop-dispenser bottles with polypropylene dropping closure and cap, 30 and 60-mL sizes.<sup>3</sup> Squeeze deliveries are made with these burets. They are placed in a secondary, cut-off, slightly larger diameter polyethylene bottle to prevent mass changes from contact with the hands. Burets are transferred to and from the balance using forceps.

7.2 *Digital Voltmeter*, d-c precision, readable to 0.2 mv.<sup>4</sup>

7.3 *Microelectrode*, rotating platinum.<sup>5</sup>

7.4 *Reference Mercury Electrode*, saturated mercurous sulfate.<sup>6</sup>

7.5 *Titration/Detector*, amperometric (see Fig. 1).

### 8. Reagents

8.1 *Purity of Reagents*—Reagent grade chemicals shall be used in all tests. Unless otherwise indicated, it is intended that all reagents conform to the specifications of the Committee on Analytical Reagents of the American Chemical Society where such specifications are available.<sup>7</sup> Other grades may be used, provided it is first ascertained that the reagent is of sufficient high purity to permit its use without lessening the accuracy of the determination.

8.2 *Purity of Water*—Unless otherwise indicated, references to water shall be understood to mean deionized or distilled water.

8.3 *Argentic Oxide* (AgO).

<sup>3</sup> Nalgene drop-dispenser bottles, Nos. 2411-0030 and 2411-0060 have been found satisfactory.

<sup>4</sup> Both Ealing Pye Scalamp Microammeter No. 29-222 and Keithley Model 197 Digital Multimeter have been found satisfactory.

<sup>5</sup> Both Sargent & Co. No. S-30420 with No. S-76485 synchronous rotator and Brinkmann Model 2.628.0010 (628-10, 68-50) have been found satisfactory.

<sup>6</sup> Brinkmann Model EA 406 has been found satisfactory.

<sup>7</sup> "Reagent Chemicals, American Chemical Society Specifications," Am. Chemical Soc., Washington, DC. For suggestions on the testing of reagents not listed by the American Chemical Society, see "Reagent Chemicals and Standards," by Joseph Rosin, D. Van Nostrand Co., Inc., New York, NY, and the "United States Pharmacopeia."

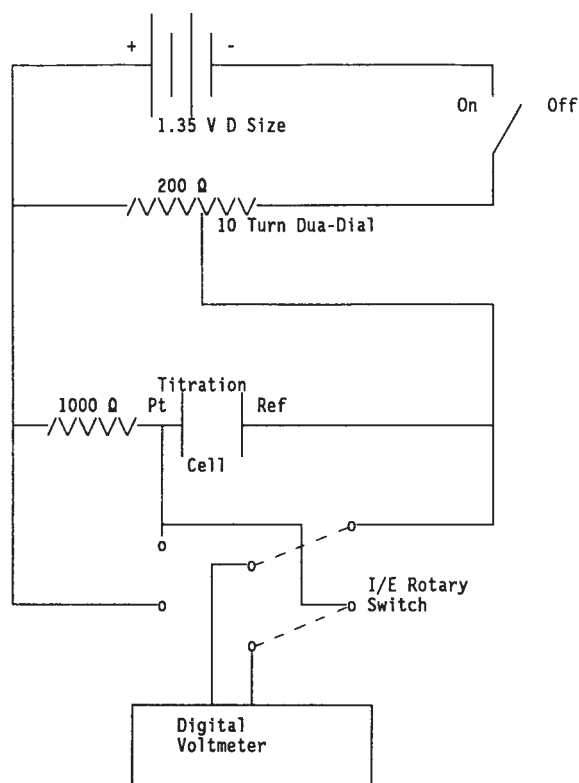

FIG. 1 Amperometric Detector Circuit

8.4 *Ferrous Ammonium Sulfate Solution, Iron (II) Titrant*—Dissolve 19.6 g of  $\text{Fe}(\text{NH}_4)_2(\text{SO}_4)_2 \cdot 6 \text{H}_2\text{O}$  in 500 mL of cold 1 N  $\text{H}_2\text{SO}_4$  and dilute to 1 L with 1 N  $\text{H}_2\text{SO}_4$ . The solution is standardized daily or before beginning a series of plutonium standard and sample titrations, or both.

8.5 *Potassium Dichromate Solution*—Use NIST SRM 136e<sup>8</sup> or equivalent. Weigh approximately 4.9 g to nearest 0.0001 g of potassium dichromate ( $\text{K}_2\text{Cr}_2\text{O}_7$ ) and dissolve in water. Transfer to a tared 2-L volumetric flask. Dilute to volume with water. Weigh the flask and contents. Make the buoyancy correction and determine the mass of the solution. Express the oxidizing strength as milliequivalents per gram of solution (C1).

$$C1 = \frac{K \times P \times B}{E \times S} \quad (1)$$

where:

- C1 =  $\text{K}_2\text{Cr}_2\text{O}_7$  concentration, milliequivalents per gram,
- K = weight, mg,  $\text{K}_2\text{Cr}_2\text{O}_7$ ,
- P = purity of  $\text{K}_2\text{Cr}_2\text{O}_7$ ,
- B = buoyancy correction for  $\text{K}_2\text{Cr}_2\text{O}_7$ , 1.00031 (use only if significant),
- E = equivalent weight of  $\text{K}_2\text{Cr}_2\text{O}_7$ , 49.0320, and
- S = weight of solution, g.

8.6 *Sulfuric Acid (0.5 N)*—Prepare by adding 14 mL of sulfuric acid ( $\text{H}_2\text{SO}_4$ , sp gr 1.84) to water with stirring and dilute to 1 L.

8.7 *Sulfuric Acid (1 N)*—Prepare by adding 28 mL of  $\text{H}_2\text{SO}_4$  (sp gr 1.84) to water with stirring and dilute to 1 L.

8.8 *Sulfuric Acid (18 N)*—Prepare by carefully adding (with continuous stirring) 500 mL of  $\text{H}_2\text{SO}_4$  (sp gr 1.84) slowly to 450 mL water, cool, and dilute to 1 L.

## 9. Standardization of Iron (II) Titrant

9.1 Transfer 20 mL water and 10 mL of 18 N  $\text{H}_2\text{SO}_4$  to a clean 50-mL beaker. Add a small stirring bar.

9.2 Place the beaker under the electrode assembly and support the beaker with a small magnetic stirrer so that the electrodes are immersed near the center. Start the rotation of the platinum electrode and turn on the magnetic stirrer.

NOTE 1—Some magnetic stirrers will cause digital voltmeter instability possibly due to a bad ground. The titration may be run with such a stirrer if it is turned off just before each current reading.

<sup>8</sup> Available from National Institute of Standards and Technology, Gaithersburg, MD 20899.

9.3 Turn on the digital voltmeter and amperometric endpoint detector. Turn the detector I/E switch to the “E” (potential) position. Adjust the voltage to 600 mV, then turn the switch to “I” (current) and observe and record the residual current (A0). The current should be less than 0.2  $\mu\text{A}$ . (See Note 2.)

9.4 Tare weigh both the dichromate (D1) and iron (F1) burets.

9.5 Add about 2 g (60 to 70 drops) of the dichromate solution into the beaker.

9.6 Add iron solution until a current reading of 10 to 15  $\mu\text{A}$  is reached. Backtitrate with dichromate solution until a current reading of 5 to 10  $\mu\text{A}$  is reached. Reweigh dichromate (D2) and iron (F2) burets and record the current (A1) reading.

9.7 Carefully add more dichromate solution until a current reading of 1 to 3  $\mu\text{A}$  is reached. Reweigh buret (D3) and record current (A2) reading.

9.8 Remove the electrodes and rinse thoroughly with 1.0 N  $\text{H}_2\text{SO}_4$  and deionized water. The apparatus is now ready for the next sample.

9.9 Determine from Section 10 the range of three titrations (highest milliequivalent per gram minus lowest milliequivalent per gram). Repeat if the range of the three titrations is greater than 0.1 %.

## 10. Procedure

10.1 *Sample Dissolution*—Refer to C1168 for detailed plutonium dissolution techniques. (Net sample weight is G1–G0; refer to Section 11, Calculation). For plutonium nitrate solutions, proceed to 10.2; otherwise proceed to 10.3.

10.2 *Plutonium Nitrate Sample Preparation*—Transfer aliquants (150 to 350 mg Pu) of plutonium nitrate solution directly into a 30-mL tared weighing buret (BO) and reweigh (S1). Add 1.0 N  $\text{H}_2\text{SO}_4$  to obtain a final Pu concentration of 5 to 12 mg/g of solution and reweigh the buret (B1). The original sample aliquant and dilution are made in the same buret. Since the transfer to the weighing buret has been made, proceed to 10.4.

10.3 Transfer the solution of the sample to tared ( $\pm 0.1$  mg) 60-mL weighing buret (BO). Rinse the dissolution container several times with 0.5 N  $\text{H}_2\text{SO}_4$  to complete the transfer. Replace cap and reweigh (B1) to nearest 0.1 mg.

10.4 Transfer by weight an aliquant of sample (B2–B3) to contain 7 to 15 mg Pu to a 50-mL beaker.

10.4.1 For solutions containing HCl and samples dissolved by acid or sealed tube dissolution add 3 drops 18 N  $\text{H}_2\text{SO}_4$  (sp gr 1.84) and heat to fumes on hot plate. When fuming ceases, remove from hot plate (Do not bake.). Cool. This step is not required for solutions not containing HCl.

10.4.2 Add 10 mL 0.5 N  $\text{H}_2\text{SO}_4$ .

10.5 Add approximately 50 mg of  $\text{AgO}$  to the solution. Gently swirl the beaker. Let stand for 30 min with occasional swirling. Perform the procedure described in Section 9, Standardization of Titrant, while waiting.

10.5.1 Incomplete oxidation of the plutonium can occur at high sulfuric acid concentrations. The presence of an excess of oxidant is shown by a characteristic blackish-brown color or a black precipitate. If the dark color does not persist, add more  $\text{AgO}$  in 10-mg increments to complete the oxidation.

10.6 Add 1 N  $\text{H}_2\text{SO}_4$  to bring the total volume to about 20 mL. Rinse the sides of the beaker while adding the acid. Heat (+80°C) to destroy excess black  $\text{AgO}$ . Cool to less than 40°C. Add a small stirring bar.

10.7 Place the beaker under the electrode assembly and support with a small magnetic stirrer so that the electrodes are immersed near the center. Start the rotation of the platinum electrode and turn on the magnetic stirrer. (See 10.5.1.)

10.8 Slowly add 10 mL of 18 N  $\text{H}_2\text{SO}_4$  while washing the inner surface of the beaker with the acid.

10.9 Turn on the digital voltmeter and amperometric endpoint detector. Turn the detector I/E switch to the “E” (potential) position.

10.10 Adjust the potential to 600 mV, then turn the I/E switch to “I” (current) and observe and record the residual current (A0). The residual current should be less than 0.2  $\mu\text{A}$ .

NOTE 2—A persistent higher residual current ( $>0.2$   $\mu\text{A}$ ) indicates the presence of interfering ions which are being oxidized at the platinum electrode.

10.11 Tare weigh the dichromate (D1) and the standardized iron (F1) solution weighing burets.

10.12 Slowly add, dropwise, increments of the standardized iron solution until a current of 10 to 15  $\mu\text{A}$  is attained. Reweigh the iron solution weighing buret (F2).

10.13 Slowly backtitrate the excess iron (II) with standard potassium dichromate solution to a current reading of 5 to 10  $\mu\text{A}$ . Reweigh the dichromate solution weighing buret (D2) and record the current (A1) reading.

10.14 Carefully add more dichromate until a current reading of 1 to 3  $\mu\text{A}$  is attained. Reweigh the dichromate solution weighing buret (D3) and record the current (A2) reading.

10.15 Calculate the sample result as described in Section 11.

10.16 Remove the electrodes from the titration solution, rinse the electrodes thoroughly with 1 N  $\text{H}_2\text{SO}_4$ , and then rinse the electrodes with deionized water. The apparatus is now ready for the next sample.

## 11. Calculation

11.1 Calculate plutonium content and ferrous standardization as follows:

11.1.1 *Ferrous Standardization:*

 **C 1206 – 02**

$$CO, \text{ meq/g} = \frac{\left[ (D1-D3) + \frac{(A2-A0)(D2-D3)}{(A1-A2)} \right] C1}{(F1-F2)} \quad (2)$$

### 11.1.2 Solid Samples:

$$Pu, \% = \frac{\left[ (F1-F2) C0 - \left[ (D1-D3) + \frac{(A2-A0) (D2-D3)}{(A1-A2)} \right] C1 \right] \cdot [W(B1-B0)] 100}{(G1-G0) (B2-B3) (1000) (2)} \quad (3)$$

### 11.1.3 Solution Samples:

$$Pu/g \text{ solution, mg} = \frac{\left[ (F1-F2) C0 - \left[ (D1-D3) + \frac{(A2-A0) (D2-D3)}{(A1-A2)} \right] C1 \right] \cdot [W(B1-B0)]}{(S1-B0) (B2-B3) (2)} \quad (4)$$

where:

- F1 = first ferrous ammonium sulfate buret weight, g,
- F2 = second ferrous ammonium sulfate buret weight, g,
- C0 = concentration of ferrous ammonium sulfate solution, milliequivalents per gram of solution,
- D1 = first potassium dichromate solution buret weight, g,
- D2 = second potassium dichromate solution buret weight, g,
- D3 = third potassium dichromate solution buret weight, g,
- A0 = residual current,
- A1 = first ammeter reading,
- A2 = second ammeter reading,
- C1 = concentration of potassium dichromate solution, milliequivalents per gram of solution,
- W = atomic weight of plutonium in sample (see Note 3),
- B0 = empty sample/dilution buret weight, g,
- B1 = full sample buret weight, g,
- B2 = sample buret weight before dispensing aliquant, g,
- B3 = sample buret weight after dispensing aliquant, g,
- G1–G0 = net weight of solid samples, g,
- S1 = weight of sample/dilution buret plus sample, g.

NOTE 3—Adjust atomic weight for isotopic composition.

## 12. Precision and Bias <sup>9</sup>

12.1 The precision (relative standard deviation) of the method is 0.1 % based on 64 measurements from 5 separate mixed oxide solutions of the same Safeguards Analytical Laboratory Evaluation (SALE) Program standard taken over a 12-month period in a single laboratory.

12.2 Based on the same measurements there was no statistically significant bias.

## 13. Keywords

### 13.1 amperometric; plutonium analysis; plutonium-uranium mixed oxides (MOX)

<sup>9</sup> Supporting data are available from ASTM Headquarters. Request RR: C26-1003.

*ASTM International takes no position respecting the validity of any patent rights asserted in connection with any item mentioned in this standard. Users of this standard are expressly advised that determination of the validity of any such patent rights, and the risk of infringement of such rights, are entirely their own responsibility.*

*This standard is subject to revision at any time by the responsible technical committee and must be reviewed every five years and if not revised, either reapproved or withdrawn. Your comments are invited either for revision of this standard or for additional standards and should be addressed to ASTM International Headquarters. Your comments will receive careful consideration at a meeting of the responsible technical committee, which you may attend. If you feel that your comments have not received a fair hearing you should make your views known to the ASTM Committee on Standards, at the address shown below.*

*This standard is copyrighted by ASTM International, 100 Barr Harbor Drive, PO Box C700, West Conshohocken, PA 19428-2959, United States. Individual reprints (single or multiple copies) of this standard may be obtained by contacting ASTM at the above address or at 610-832-9585 (phone), 610-832-9555 (fax), or service@astm.org (e-mail); or through the ASTM website (www.astm.org).*