



**Designation: C 1269 – 97**

## **Standard Practice for Adjusting the Operational Sensitivity Setting of In-Plant Walk-Through Metal Detectors<sup>1</sup>**

This standard is issued under the fixed designation C 1269; the number immediately following the designation indicates the year of original adoption or, in the case of revision, the year of last revision. A number in parentheses indicates the year of last reapproval. A superscript epsilon ( $\epsilon$ ) indicates an editorial change since the last revision or reapproval.

### **INTRODUCTION**

Nuclear regulatory authorities require personnel entering designated security areas to be screened for concealed weapons. Additionally, in security areas containing specified quantities of special nuclear materials, personnel exiting the facility are required to be screened for metallic nuclear shielding material. Walk-through metal detectors are widely used to implement these requirements. Nuclear regulatory authorities usually specify an assortment of metal detector test objects that must all be detected by walk-through metal detectors. This practice provides a procedure for adjusting the operational sensitivity setting to the lowest setting necessary to detect the least likely to-be-detected test object in its least likely to-be-detected orientation while passing through the detection zone in the weakest known detection path. All other test objects will then be detected at this sensitivity setting anywhere in the detection zone.

### **1. Scope**

1.1 This practice covers a procedure for adjusting the operational sensitivity of in-plant walk-through metal detectors. Performance of this procedure should result with in-plant walk-through metal detectors being adjusted to an initial operational sensitivity setting suitable for performance testing.

1.2 This practice does not set test object specifications or specify specific test objects. These should be specified by the regulatory authority.

1.3 This practice uses information developed by Practice C 1270, or an equivalent procedure, which identifies the critical test object (from a specified set of test objects), its critical orientation, and the critical test path through the detection zone. In the case of Practice C 1270, the information is found on the detection sensitivity map(s) for each in-plant walk-through metal detector.

1.4 This practice is one of several developed to assist operators of nuclear facilities with meeting the metal detection performance requirements of the regulatory authorities (see Appendix).

1.5 This standard practice is neither intended to set performance levels nor limit or constrain technologies.

1.6 This practice does not address safety or operational issues associated with the use of walk-through metal detectors.

1.7 The values stated in SI units are to be regarded as

standards. The values given in parentheses are for information only.

### **2. Referenced Documents**

#### *2.1 ASTM Standards:*

C 1238 Guide for Installation of Walk-Through Metal Detectors<sup>2</sup>

C 1270 Practice for Detection Sensitivity Mapping of In-Plant Walk-Through Metal Detectors<sup>2</sup>

C 1309 Practice for Performance Evaluation of In-Plant Walk-Through Metal Detectors

F 1468 Practice for the Evaluation of Metallic Weapons Detectors for Controlled Access Search and Screening<sup>3</sup>

### **3. Terminology**

#### *3.1 Definitions of Terms Specific to This Standard:*

3.1.1 *clean-tester, n*—a person who does not carry any extraneous metallic objects that would significantly alter the signal produced when the person carries a test object.

3.1.1.1 *Discussion*—Smaller test objects require more complete elimination of metallic objects. By example but not limitation, such extraneous metallic objects may include: metallic belt buckles, metal buttons, cardiac pacemakers, coins, metal frame eyeglasses, hearing aids, jewelry, keys, mechanical pens and pencils, shoes with metal shanks or arch supports, metallic surgical implants, undergarment support metal, metal zippers, etc. In the absence of other criteria, a clean tester

<sup>1</sup> This practice is under the jurisdiction of ASTM Committee C26 on Nuclear Fuel Cycle and is the direct responsibility of Subcommittee C26.12 on Safeguard Applications.

Current edition approved Dec. 10, 1997. Published June 1998. Originally published as C 1269 – 00. Last previous edition C 1269 – 94.

<sup>2</sup> *Annual Book of ASTM Standards*, Vol 12.01.

<sup>3</sup> *Annual Book of ASTM Standards*, Vol 15.07.

passing through a metal detector shall not cause a disturbance signal greater than 10 % of that produced when carrying the critical test object through the detector. Test objects requiring more complete elimination of extraneous metal to obtain less than 10 % signal disturbance.

3.1.1.2 *Discussion*—The tester shall have a weight between 50 to 104 kg (110 to 230 lb) and a height between 1.44 to 1.93 m (57 to 75 in.). Should a given detector be sensitive to body size because of design or desired sensitivity, the physical size of testers should be smaller and within a narrower range.

3.1.1.3 *Discussion*—It is recommended that the clean tester be surveyed with a high sensitivity hand-held metal detector to ensure that no metal is present.

3.1.2 *critical orientation*—the orthogonal orientation of a test object that produces the smallest detection signal or weakest detection anywhere in the detection zone; the orthogonal orientation of a test object that requires a higher sensitivity setting to be detected compared to the sensitivity settings required to detect the object in all other orthogonal orientations. See Fig. 1 for handgun orientations

3.1.2.1 *Discussion*—Critical orientations are determined by testing using a mapping procedure such as described in Practice C 1270.

3.1.2.2 *Discussion*—The term critical orientation can be applied in two ways. Critical orientation can refer to the worst case orthogonal orientation in a single test path or the worst case orthogonal orientation for all the test paths (the entire detection zone). The two are coincident in the critical test path.

3.1.3 *critical sensitivity setting, n*—the lowest sensitivity setting of a detector at which the critical test object in its critical orientation is consistently detected (10 out of 10 test passes) when passed through the detection zone on the critical test path.

3.1.4 *critical test element, n*—see **test element**.

3.1.5 *critical test object, n*—see **test object**.

3.1.6 *critical test path, n*—the straight-line shortest-course path through the portal aperture, as defined by an element on the detection sensitivity map, that produces the smallest detection signal or weakest detection for the critical test object in its critical orientation. (see Figs. 2 and 3)

3.1.7 *detection sensitivity map, n*—(see Fig. 2) a depiction of the grid used to define test paths through the detection zone

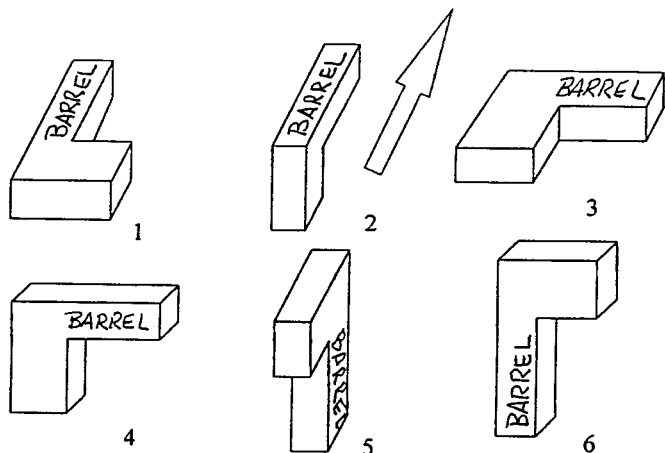

**FIG. 1 Six Standard Orthogonal Orientations for a Handgun**

52	68	52	52
49	55	75	71
50	52	75	73
48	58	74	70
35	63	81	72
47	62	89	74
47	69	79	75
57	71	81	79
62	74	74	69

critical test element

NOTE 1—Numbers are sensitivity setting values for a hypothetical detector. The numbers represent the lowest sensitivity setting at which the object was detected ten out of ten consecutive test passes through the indicated test path.

**FIG. 2 Example of Detection Sensitivity Map**

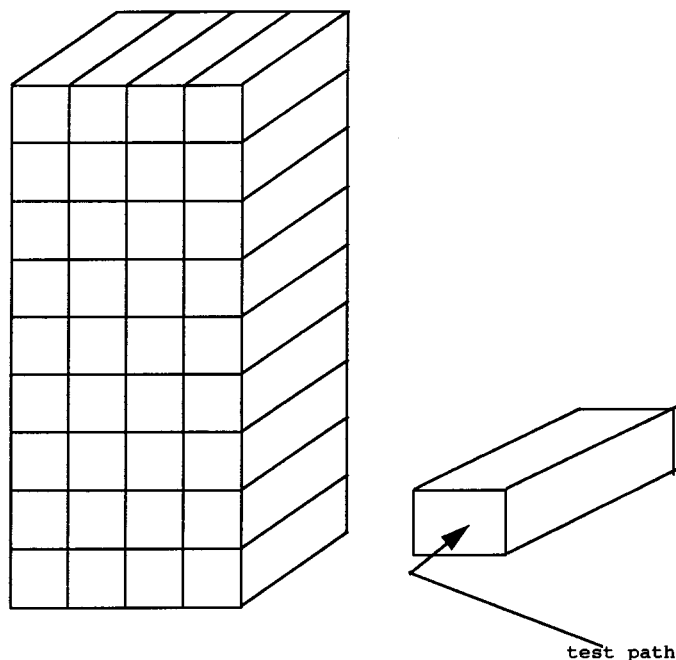

**FIG. 3 3-D View of Detection Zones and Test Grid**

with each element of the grid containing a value, usually the sensitivity setting of the detector, that is indicative of the detectability of the test object.

3.1.7.1 *Discussion*—These values are relative and describe the detection sensitivity pattern within the detection zone for the specific test object. The values are derived by identically testing each defined test path using a specific test object in a single orthogonal orientation. The value is usually the minimum sensitivity setting of the detector that will cause a consistent alarm (10 out of 10 test passes) when the test object

is passed through the detection field. Appendix X2 is a sample form for a potential detection sensitivity map configuration.

3.1.8 *detection zone*—the volume within the portal aperture.

3.1.9 *detector, n*—see **walk-through metal detector**.

3.1.10 *element, n*—see **test element**.

3.1.11 *grid, n*—see **test grid**.

3.1.12 *grid element, n*—(1) a single block on a detection sensitivity map; (2) the rectilinear volume through the detection zone defined by coincident elements of identical grid works placed on either side of the portal aperture. (see Figs. 2 and 3)

3.1.12.1 *test path, n*—as defined by an element on a detection sensitivity map, a straight-line shortest-course path through the detection zone of a detector undergoing mapping, detection sensitivity, or detection sensitivity verification testing. (see Fig. 3)

3.1.13 *in-plant, adj*—installed in the location, position, and operating environment where the device will be used.

3.1.14 *orthogonal orientation*—as used in this practice, orthogonal orientation refers to alignment of the longitudinal axis of a test object along the *xyz* axes of the Cartesian coordinate system; *x* is horizontal and across the portal, *y* is vertical, and *z* is in the direction of travel through the portal.

3.1.15 *portal, n*—see **walk-through metal detector**. (See Fig. 1 for handgun orientations)

3.1.16 *test element, n*—(see Figs. 2 and 3) for the purpose of testing, it is necessary to define discrete and repeatable straight-line shortest-course test paths through the detection zone. This can be done by using two identical networks (grids) made of nonconductive/nonmagnetic material attached across the entry and exit planes of the portal aperture so the networks coincide. A test object on the end of a probe can then be passed from one side of the portal aperture to the other side through corresponding openings, which results in the test object taking a reasonably straight-line shortest-course path through the detection zone. If the networks are constructed so that they can be put in-place identically each time they are used, then the test paths through the detection zone are repeatable over time. Thus, a test element is the volume of space defined by the boundaries of two corresponding network openings and it represents a straight-line shortest-course path through the detection zone.

3.1.16.1 *Discussion*—On a detection sensitivity map the corresponding networks appear as a rectangular grid with each element of the grid representing a test path through the detection zone. The element defining the critical test path is the critical test element.

3.1.17 *test grid, n*—a network of nonconductive/nonmagnetic material, such as string or tape, can be stretched across the entry and exit planes of the portal aperture to define test paths through the portal aperture; the material should not be hygroscopic.

3.1.17.1 *Discussion*—See Fig. 2 for an example of a 4 by 9 element test grid.

3.1.18 *test object, n*—metallic item meeting dimension and material criteria used to evaluate detection performance.

3.1.18.1 *critical test object*—the one test object out of any given group of test objects that, in its critical orientation,

produces the weakest detection signal anywhere in the detection zone. The group referred to consists of one or more objects that are to be detected at the same detector setting.

3.1.18.2 *Discussion*—Depending on the particular detector, some orientation sensitive test objects may have orientations at different locations in the detection zone that result in near critical sensitivity settings. Hence, care must be taken in determining the critical test object, its critical orientation, and the critical test path.

3.1.18.3 *shielding test object*—a test object representing special nuclear material shielding that might be used in a theft scenario.

3.1.18.4 *Discussion*—It is usually a metallic container or metallic material configured as a credible gamma-radiation shield for a specific type and quantity of special nuclear material. The object is specified by a regulatory authority or is based on the facility threat analysis, or both.

3.1.18.5 *weapon test object, n*—a handgun(s) or simulated handgun designated by or satisfying the regulatory authority requirement for a weapon test object.

3.1.18.6 *Discussion*—Care must be taken when selecting or designing a mock handgun. Simple blocks of metal shaped like a handgun will likely not cause a metal detector to react the same as it would to the intricate shapes and variable components of a real handgun. Most government agencies use actual guns for testing.

3.1.19 *walk-through metal detector (detector, portal), n*—a free-standing screening device, usually an arch-type portal, using an electromagnetic field within its portal structure (aperture) for detecting metallic objects, specifically weapons or metallic shielding material, or both, on persons walking through the portal.

3.1.20 *walk speed (normal), n*—walk speed is between 0.5 to 1.3 m/s (1½to 2½steps/s).

3.1.20.1 *Discussion*—The average casual walk rate is about 1¾ steps/s.

3.1.20.2 *shielding test object, n*—see **test object**.

3.1.20.3 *weapon test object, n*—see **test object**.

## 4. Summary of Practice

4.1 A clean-tester carries the critical test object in the critical orientation through the critical test element in the normal operating fashion. The metal detector sensitivity is adjusted upward, starting from a setting where no alarms occur, until the lowest sensitivity setting is found where 10 consecutive passes result with 10 consecutive alarms. This value is the initial operational sensitivity setting.

## 5. Significance and Use

5.1 Performing this procedure from this practice should result in a properly adjusted walk-through metal detector operating at or near the optimum sensitivity setting for the environment in which it is installed.

5.2 This practice determines the lowest sensitivity setting required to detect a specified test object and establishes a sensitivity setting suitable for most operational needs.

5.3 This practice may be used to establish an initial sensitivity setting for follow-on procedures that determine credible values for probability of detection and confidence level, as

required by regulatory authorities.

## 6. Precautions

6.1 This practice assumes no changes in the metal detection pattern or sensitivity from the time of initial detection sensitivity mapping. If an event or circumstance has occurred that may effect a change in the detection field or sensitivity, such as damage to the detector or changes in the operating environment, make sure that the detection zone is mapped again. The detector must be mapped following maintenance on the detector controller or archway internal parts, after movement of the detector for any reason, and when architecture, electrical and mechanical equipment, or furnishings are added, removed or substantially changed within approximately 10 m of the detector. It is suggested that detectors be mapped yearly as part of a maintenance program to ensure no unrecognized changes have taken place in the detector or its environment that affect detection performance.

6.2 Because of the large number of variables certain to arise with field installations and operating methods (for example, continuous walk versus pausing in the portal) caution should always be observed when applying this practice. It is advisable to thoroughly map each metal detector type and installation with all regulator specified test objects to determine the worst-case before implementing this practice.

## 7. Interferences

7.1 A number of external and operational interferences may affect sensitivity adjustment and performance test results. These are addressed in Guide C 1238 and Practice F 1468.

## 8. Prerequisites

8.1 The detector must have been mapped by some method in accordance with Practice C 1270 to identify the critical test object, critical test element, and critical test object orientation. This information must be available.

8.2 Ensure the area around the detector contains all materials normally present; no material shall be removed purely for performance of this practice.

8.3 Ensure that only the walk-tester is within 1 m (3 ft) of the detector.

8.4 Radios, pagers, and other electronic equipment that are not part of the building or security system should be at least 3 m (10 ft) away.

8.5 Energize all equipment located within 10 m (33 ft) of the detector that is normally "on" during routine operation.

8.6 The tester must be a clean-tester as described in 3.1.

8.7 In the case of detectors used bidirectionally, ensure testing is performed using the worst-case direction of travel.

## 9. Frequency

9.1 This practice is performed prior to putting in-plant walk-through metal detectors into screening service and when required by schedule or circumstance (for example, equipment moved, repaired or replaced).

## 10. Test Object

10.1 This practice uses the critical test object from a set of test objects specified by the regulatory authority. The critical

test object is determined by in-plant sensitivity mapping (or an equivalent procedure) of each detector. When a detection sensitivity map is used, the critical test object is noted on the map for the detector being adjusted.

## 11. Procedure

11.1 Refer to the detection sensitivity map (Fig. 2) (or equivalent).

11.1.1 Select the proper test object for the type of screening the detector is to perform (weapons or shielding).

11.1.2 Select the critical test element in the space normally occupied by a person passing through the detection field for the selected test object. This test element is used for all test passes.

11.1.3 Note the direction of travel relative to the transmitter-receiver location.

11.2 Place or attach the critical test object on a clean-tester or have the clean-tester carry the critical test object so it will be in its critical orientation as it passes through the critical test element during a normal passage as required by the facility operating procedures. If the critical test element is located between the knee and the floor and the normal passage procedure does not require the searchee to pause in the detection zone it will be necessary to determine if sweeping-through (kick-through) or stopping the test object in the detection zone is the worst-case situation.

11.3 Beginning at a low sensitivity setting, make several passes through the detector and adjust the sensitivity upwards until the lowest sensitivity setting is found that results in at least 10 consecutive alarms. This sensitivity setting value is the initial detection sensitivity setting.

11.4 Verify effective detector operation by performing 10 test passes with the test object located on the centerline of the portal at the top of the head as if under a hat, at the waist, and at the inside of the ankle. Use the worst-case orientation for the test object in the element being tested and not the critical orientation, unless it is the same. If the normal passage procedure does not require a pause, test the ankle position using both a kick-through and a pause in the detection zone. In the case of detectors located at manned positions, make sure that the kick-through is reasonably realistic and not an exaggerated motion that would draw attention to a person trying to avoid detection.

11.4.1 If detection is less than 100 % for any of these positions it will be necessary to increase the sensitivity setting until 10 out of 10 detection is attained in the worst-case element. Note the position and passage method that required the highest sensitivity setting.

11.5 Record the sensitivity setting and critical test element on the detection sensitivity map (Fig. 2), or as appropriate if a detection sensitivity map is not used, for future performance testing.

11.5.1 If the verification procedure in 11.4 determines that another element, orientation, or particular means of passage, or both, is the worst-case, then that element, orientation, and method of testing shall be used for future performance testing. Note this on the detection sensitivity map, or as appropriate if a detection sensitivity map is not used.

11.6 The detector adjustment is complete and the detector can be tested using a suitable performance testing procedure to





determine or validate the performance for the applicable regulatory requirements.

nel screening; physical security; special nuclear material; walk-through metal detector

## 12. Keywords

12.1 entry control; metal detection; metal detector; person-

## APPENDICES

(Nonmandatory Information)

### X1. WALK-THROUGH METAL DETECTOR TESTING PROGRAM

X1.1 Fig. X1.1 follows.

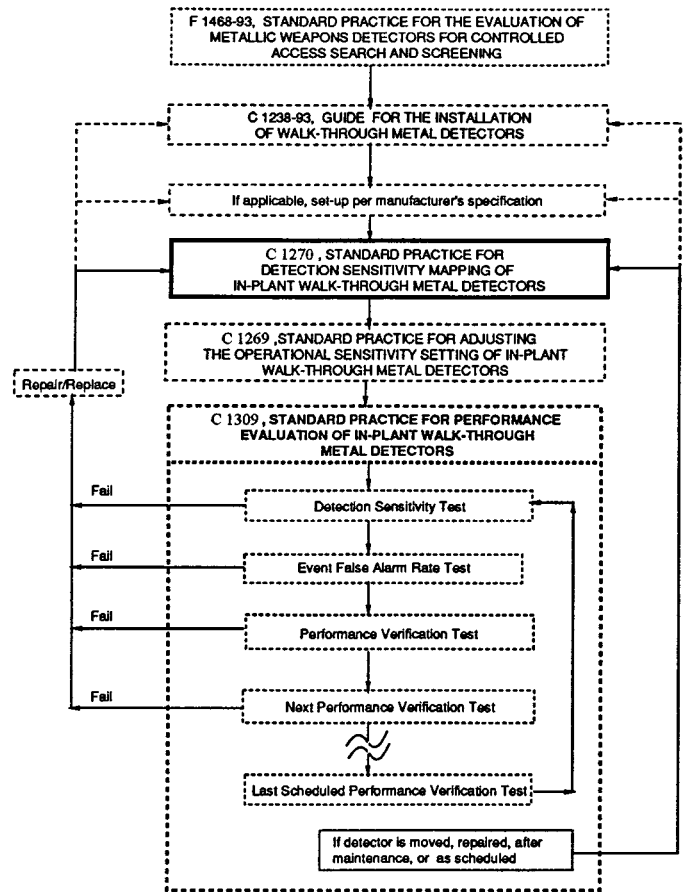

FIG. X1.1 Procedures for Walk-Through Metal Detector Program



**X2. FORM—DETECTION SENSITIVITY MAP**

1	2	3	4
5	6	7	8
9	10	11	12
13	14	15	16
17	18	19	20
21	22	23	24
25	26	27	28
29	30	31	32
33	34	35	36

NOTE X2.1—Important: Ensure the location of the transmitter and receiver are identified. If the detector does not have a dedicated transmitter and receiver, note the side from which testing is performed relative to the protected area.

Manufacturer: \_\_\_\_\_ Weapon Test Object ID No.: \_\_\_\_\_  
 Model: \_\_\_\_\_ Shielding Test Object ID No.: \_\_\_\_\_  
 Date Tested: \_\_\_\_\_ Tester sign: \_\_\_\_\_  
 Location: \_\_\_\_\_ Verification sign: \_\_\_\_\_  
 Parameter Settings: \_\_\_\_\_ Orientation: \_\_\_\_\_

*ASTM International takes no position respecting the validity of any patent rights asserted in connection with any item mentioned in this standard. Users of this standard are expressly advised that determination of the validity of any such patent rights, and the risk of infringement of such rights, are entirely their own responsibility.*

*This standard is subject to revision at any time by the responsible technical committee and must be reviewed every five years and if not revised, either reapproved or withdrawn. Your comments are invited either for revision of this standard or for additional standards and should be addressed to ASTM International Headquarters. Your comments will receive careful consideration at a meeting of the responsible technical committee, which you may attend. If you feel that your comments have not received a fair hearing you should make your views known to the ASTM Committee on Standards, at the address shown below.*

*This standard is copyrighted by ASTM International, 100 Barr Harbor Drive, PO Box C700, West Conshohocken, PA 19428-2959, United States. Individual reprints (single or multiple copies) of this standard may be obtained by contacting ASTM at the above address or at 610-832-9585 (phone), 610-832-9555 (fax), or service@astm.org (e-mail); or through the ASTM website (www.astm.org).*