



**Designation: C 1270 – 97**

## **Standard Practice for Detection Sensitivity Mapping of In-Plant Walk-Through Metal Detectors<sup>1</sup>**

This standard is issued under the fixed designation C 1270; the number immediately following the designation indicates the year of original adoption or, in the case of revision, the year of last revision. A number in parentheses indicates the year of last reapproval. A superscript epsilon ( $\epsilon$ ) indicates an editorial change since the last revision or reapproval.

### **INTRODUCTION**

Nuclear regulatory authorities require personnel entering designated security areas to be screened for concealed weapons. Additionally, in security areas containing specified quantities of special nuclear materials, exiting personnel are required to be screened for metallic nuclear shielding material. Walk-through metal detectors are widely used to implement these requirements.

A number of environmental conditions, architectural and electrical arrangements near the detector, and detector characteristics affect the detection of metallic objects passing through the walk-through metal detector. These external effects and detector characteristics are discussed in Practices F 1468 and C 1269, and Guide C 1238. This practice is intended to minimize the effects of these variables on detector operation by providing the operator with baseline information on the metal detection sensitivity within the portal aperture, particularly the location of any weak areas of detection. The data is obtained by mapping the detection zone (volume within the portal) of each detector at its field location, under normal operating conditions, and using the target test object. The maps, when applied to detector operation, ensure that the effects of the fixed environmental conditions, architectural and electrical arrangements, and detector characteristics are taken into account during operational sensitivity adjustment, performance evaluation, and general operation of detectors.

### **1. Scope**

1.1 This standard practice covers a procedure for determining the weakest detection path through the portal aperture and the worst-case orthogonal orientation of metallic test objects. It results in detection sensitivity maps, which model the detection zone in terms related to detection sensitivity and identify the weakest detection paths. Detection sensitivity maps support sensitivity adjustment and performance evaluation procedures (see Practices C 1269 and C 1309).

NOTE 1—Unsymmetrical metal objects possessing a primary longitudinal component, such as handguns and knives, usually have one particular orientation that produces the weakest detection signal. The orientation and the path through the detector aperture where the weakest response is produced may not be the same for all test objects, even those with very similar appearance.

NOTE 2—In the case of multiple specified test objects or for test objects that are orientation sensitive, it may be necessary to map each object several times to determine the worst-case test object or orientation, or both.

1.2 This practice is one of several developed to assist operators of walk-through metal detectors with meeting the

metal detection performance requirements of the responsible regulatory authority. (See Appendix X2)

1.3 This practice is neither intended to set performance levels, nor limit or constrain operational technologies.

1.4 This practice does not address safety or operational issues associated with the use of walk-through metal detectors.

1.5 The values stated in SI units are to be regarded as the standard. The values given in parentheses are for information only.

### **2. Referenced Documents**

#### *2.1 ASTM Standards:*

C 1238 Guide for Installation of Walk-Through Metal Detectors<sup>2</sup>

C 1269 Practice for Adjusting the Operational Sensitivity Setting of In-Plant Walk-Through Metal Detectors<sup>2</sup>

C 1309 Practice for Performance Evaluation of In-Plant Walk-Through Metal Detectors

F 1468 Practice for the Evaluation of Metallic Weapons Detectors for Controlled Access Search and Screening<sup>3</sup>

### **3. Terminology**

#### *3.1 Definitions of Terms Specific to This Standard:*

<sup>1</sup> This practice is under the jurisdiction of ASTM Committee C26 on Nuclear Fuel Cycle and is the direct responsibility of Subcommittee C26.12 on Safeguard Applications.

Current edition approved Dec. 10, 1997. Published June 1998.

<sup>2</sup> *Annual Book of ASTM Standards*, Vol 12.01.

<sup>3</sup> *Annual Book of ASTM Standards*, Vol 15.07.

3.1.1 *clean-tester, n*—a person who does not carry any extraneous metallic objects that would significantly alter the signal produced when the person carries a test object.

3.1.1.1 *Discussion*—By example but not limitation, such extraneous metallic objects may include: metallic belt buckles, metal buttons, cardiac pacemakers, coins, metal frame eye glasses, hearing aids, jewelry, keys, mechanical pens and pencils, shoes with metal shanks or arch supports, metallic surgical implants, undergarment support metal, metal zippers, etc. In the absence of other criteria, a clean tester passing through a metal detector shall not cause a disturbance signal greater than 10 % of that produced when carrying the critical test object through the detector. Test objects requiring very high sensitivity settings for detection require more complete elimination of extraneous metal to obtain less than 10 % signal disturbance.

3.1.1.2 *Discussion*—The tester shall have a weight between 50 to 104 kg (110 to 230 lb) and a height between 1.44 to 1.93 m (57 to 75 in.). Should a given detector be sensitive to body size because of design or desired sensitivity, the physical size of testers should be smaller and within a narrower range.

3.1.1.3 *Discussion*—It is recommended that the clean tester be surveyed with a high sensitivity hand-held metal detector to ensure that no metal is present.

3.1.2 *critical orientation, n*—the orthogonal orientation of a test object that produces the smallest detection signal or weakest detection anywhere in the detection zone; the orthogonal orientation of a test object that requires a higher sensitivity setting to be detected compared to the sensitivity setting required to detect the object in all other orthogonal orientations. See Fig. 1 for handgun orientations.

3.1.2.1 *Discussion*—Critical orientations are determined by testing using a mapping procedure such as described in Practice C 1270.

3.1.2.2 *Discussion*—The term critical orientation can refer to the worst case orthogonal orientation in a single test path or the worst case orthogonal orientation for all the test paths (the entire detection zone). The two are coincident in the critical test path.

3.1.3 *critical sensitivity setting, n*—the lowest sensitivity setting of a detector at which the critical test object in its critical orientation is consistently detected (10 out of 10 test

passes) when passed through the detection zone on the critical test path.

3.1.4 *critical test element, n*—see **test element**.

3.1.5 *critical test object, n*—see **test object**.

3.1.6 *critical test path, n*—the straight-line shortest-course path through the portal aperture, as defined by an element on the detection sensitivity map, that produces the smallest detection signal or weakest detection for a test object in its critical orientation. (see Figs. 2 and 3)

3.1.7 *detection sensitivity map, n*—(see Figs. 2 and 1) a depiction of the grid used to define test paths through the detection zone, with each element of the grid containing a value, usually the sensitivity setting of the detector, that is indicative of the detectability of the test object.

3.1.7.1 *Discussion*—These values are relative and describe the detection sensitivity pattern within the detection zone for the specific test object. The values are derived by identically testing each defined test path using a specific test object in a single orthogonal orientation. The value is usually the minimum sensitivity setting of the detector that will cause a consistent alarm (10 out of 10 test passes) when the test object is passed through the detection field. Appendix X3 is a sample form for a potential detection sensitivity map configuration.

3.1.8 *detection zone, n*—the volume within the portal aperture.

3.1.9 *detector, n*—see **walk-through metal detector**.

3.1.10 *element, n*—see test element

3.1.11 *grid, n*—see test grid

3.1.11.1 *grid element, n*—(1) a single block on a detection sensitivity map; (2) the rectilinear volume through the detection zone defined by coincident elements of identical grid

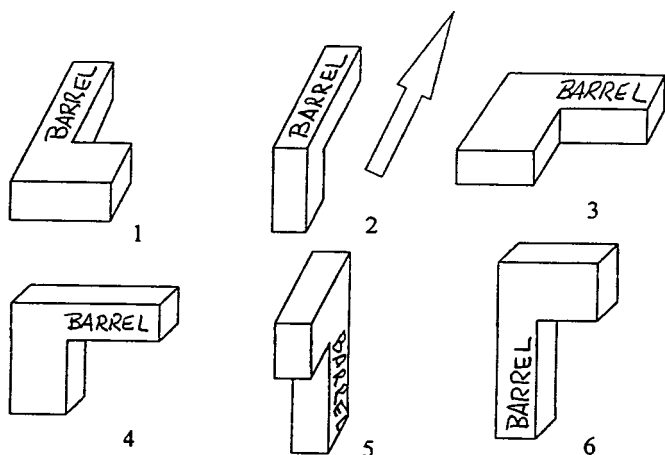

**FIG. 1 Six Standard Orthogonal Orientations for a Handgun**

52	68	52	52
49	55	75	71
50	52	75	73
48	58	74	70
35	63	81	72
47	62	89	74
47	69	79	75
57	71	81	79
62	74	74	69

critical  
test  
element

NOTE 1—Numbers are sensitivity setting values for a hypothetical detector. The numbers represent the lowest sensitivity setting at which the object was detected ten out of ten consecutive test passes through the indicated test path.

NOTE 2—*Important:* ensure that the location of the transmitter and receiver are identified. If the detector does not have a dedicated transmitter and receiver, note the side from which testing is performed relative to the protected area.

**FIG. 2 Example of Detection Sensitivity Map**

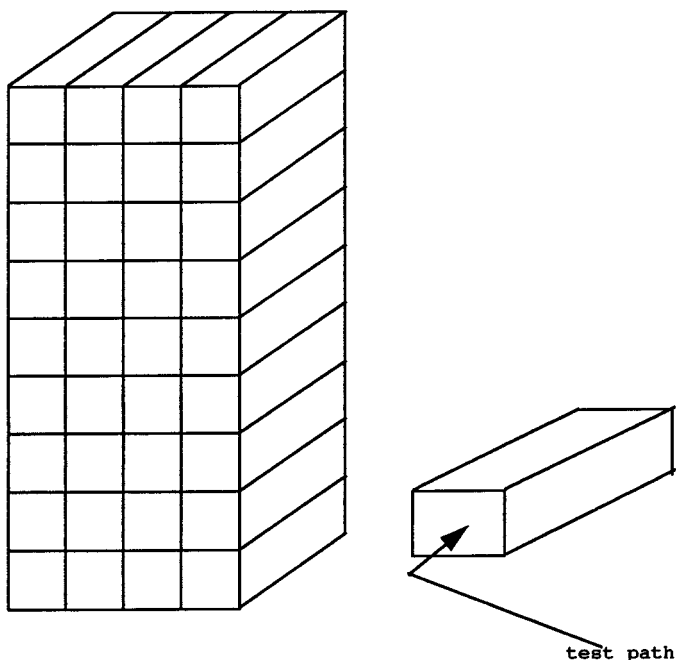

FIG. 3 3-D View of Detection Zones and Test Grid

works placed on either side of the portal aperture. (see Figs. 2 and 3)

3.1.11.2 *test path, n*—as defined by an element on a detection sensitivity map, a straight-line shortest-course path through the detection zone of a detector undergoing mapping, detection sensitivity, or detection sensitivity verification testing. (see Fig. 3)

3.1.12 *element, test element, n*—for the purpose of this testing, a test element is the volume of space defined by the boundaries of two corresponding network openings, and it represents a straight-line shortest-course path through the detection zone.

3.1.12.1 *Discussion*—It is necessary to define discrete and repeatable straight-line shortest-course test paths through the detection zone. This can be done by using two identical networks (grids) made of nonconductive/nonmagnetic material attached across the entry and exit planes of the portal aperture so the networks coincide. A test object on the end of a probe can then be passed from one side of the portal aperture to the other side through corresponding openings, which results in the test object taking a reasonably straight-line shortest-course path through the detection zone. If the networks are constructed so that they can be put in-place identically each time they are used, then the test paths through the detection zone are repeatable over time. On a detection sensitivity map the corresponding networks appear as a rectangular grid with each element of the grid representing a test path through the detection zone.

3.1.13 *in-plant, adj*—installed in the location, position, and operating environment where the device will be used.

3.1.14 *orthogonal orientation, n*—as used in this practice, orthogonal orientation refers to alignment of the longitudinal axis of a test object along the xyz axes of the Cartesian coordinate system; x is horizontal and across the portal, y is vertical, and z is in the direction of travel through the portal.

(see Fig. 1 for handgun orientations)

3.1.15 *portal, n*—see **walk-through metal detector**.

3.1.16 *test element, n*—(see Figs. 2 and 3) for the purpose of testing, it is necessary to define discrete and repeatable straight-line shortest-course test paths through the detection zone. This can be done by using two identical networks (grids) made of nonconductive/nonmagnetic material attached across the entry and exit planes of the portal aperture so the networks coincide. A test object on the end of a probe can then be passed from one side of the portal aperture to the other side through corresponding openings, which results in the test object taking a reasonably straight-line shortest-course path through the detection zone. If the networks are constructed so that they can be put in-place identically each time they are used, then the test paths through the detection zone are repeatable over time. Thus, a test element is the volume of space defined by the boundaries of two corresponding network openings and it represents a straight-line shortest-course path through the detection zone.

3.1.16.1 *Discussion*—On a detection sensitivity map the corresponding networks appear as a rectangular grid with each element of the grid representing a test path through the detection zone. The element defining the critical test path is the critical test element.

3.1.17 *test grid, n*—a network of nonconductive/nonmagnetic material, such as string or tape, can be stretched across the entry and exit planes of the portal aperture to define test paths through the portal aperture; the material should not be hygroscopic.

3.1.17.1 *Discussion*—See Fig. 2 for an example of a 4 by 9 element test grid.

3.1.18 *test object, n*—metallic item meeting dimension and material criteria used to evaluate detection performance.

3.1.18.1 *critical test object*—the one test object out of any given group of test objects that in its critical orientation, produces the weakest detection signal anywhere in the detection zone.

3.1.18.2 *Discussion*—Depending on the particular detector, some orientation sensitive test objects may have different locations in the detection zone result in near critical sensitivity settings. Hence, care must be taken in determining the critical test object, its critical orientation, and the critical test path.

3.1.18.3 *shielding test object, n*—a test object representing special nuclear material shielding that might be used in a theft scenario.

3.1.18.4 *Discussion*—It is usually a metallic container or metallic material configured as a credible gamma-radiation shield for a specific type and quantity of special nuclear material. The object is specified by a regulatory authority or is based on the facility threat analysis, or both.

3.1.18.5 *weapon test object, n*—a handgun(s) or simulated handgun designated by or satisfying the regulatory authority requirement for a test object.

3.1.18.6 *Discussion*—Care must be taken when selecting or designing a mock handgun. Simple blocks of metal shaped like a handgun will likely not cause a metal detector to react the

same as it would to the intricate shapes and variable components of a real handgun. Most government agencies use actual guns for testing.

3.1.19 *walk-through metal detector (detector, portal), n*—a free-standing screening device, usually an arch-type portal, using an electromagnetic field within its portal structure (aperture) for detecting metallic objects, specifically weapons or metallic shielding material, or both, on persons walking through the portal.

3.1.20 *walk speed (Normal), n*—walk speed is between 0.5 to 1.3 m/s (1 1/2 to 2 1/2 steps/s).

3.1.20.1 *Discussion*—The average casual walk rate is about 1 3/4 step/s.

3.1.20.2 *shielding test object, n*—see **test object**.

3.1.20.3 *weapon test object, n*—see **test object**.

#### 4. Summary of Practice

4.1 This practice describes a method for determining the metal detection sensitivity pattern within the aperture of walk-through metal detectors. It develops detection sensitivity maps for walk-through metal detectors. These maps are depictions of the grids used to define test paths through the detector with values in each element that are representative of the detection sensitivity (see Fig. 2). The values are derived by identically testing each element with the same test object in a specific orthogonal orientation. The maps identify areas of weak detection and are used during sensitivity adjustment and performance testing to assure complete detection coverage throughout the detector aperture.

4.2 This practice describes two methods for determining the values that make up the detection sensitivity map:

4.2.1 In the first, a test object, which is usually specified by requirements of the responsible regulatory authority, is passed through the detection zone in each of the identified test paths and the sensitivity is adjusted to determine the lowest sensitivity setting that results in consistent detection of the test object in each test path. These settings are the critical sensitivity settings and are the value entered in the respective elements of the detection sensitivity map.

4.2.2 If a detector has a numeric readout that is representative of the actual signal from which the detector determines an alarm condition, this value may be used for describing the detection sensitivity pattern. In this case, a specified test object is passed through each test path several times and the mean value of the responses is calculated for each element (the sensitivity adjustment must be set at a level that provides less than full scale readings for the most sensitive path through the detection zone). These mean values describe the sensitivity pattern.

4.3 Test objects that are orientation sensitive must have each orthogonal orientation tested to determine the worst-case orientation.

#### 5. Significance and Use

5.1 A complex set of variables affect metal detection and detection sensitivity. Some physical characteristics of metal objects that influence detection are material composition, shape, surface area, surface and internal electrical and magnetic properties, and finish. The orientation of a test object can

greatly influence detection as can the direction and speed or changes in speed while passing through the detection zone. Nearby large metal objects and metal moving in near proximity to a metal detector also affect operation, as do temperature and humidity, and can be a cause for nuisance alarms. Additionally, most currently manufactured walk-through metal detectors have some means for programming the operation of the detector for special conditions or requirements; these variables and the effect they have on the operation of in-plant detectors must be considered if a test program is to be effective. This practice is intended to minimize the impact of these variables on the operation of in-plant detectors by systematically testing the installed detectors in the operating environment with the test object(s) specified by the regulatory authority requirements.

5.2 This practice may be used to determine the critical test object from a group of test objects, its critical orientation, and the critical test path through the detection zone. This information may allow the use of a single test object for setting the operational sensitivity of the detector and performing periodic performance evaluations necessary to ensure a high probability that all test objects in the group are detectible within the capabilities of the detector.

5.3 The detection sensitivity map(s) generated by this practice provides baseline metal detection data for the specified test objects and can serve as a foundation for in-plant walk-through metal detector set-up and performance evaluation testing. The detection sensitivity map(s) may be incorporated into a detector performance test log in support of performance evaluation practices.

5.4 This practice may provide insight into certain metal detection characteristics of walk-through metal detectors, particularly the effect of different metals and test object orientations on detection capability, that are useful for optimizing detector sensitivity settings for detection of specified weapons or shielding material, or both.

5.5 Periodic performance of this practice and analysis of the results may provide a means to monitor the state of health of in-plant detectors and to gain further insight into detector application and operation.

#### 6. Test Objects

6.1 The test objects are generally specified or approved, or both, by the responsible regulatory authority.

#### 7. Interferences

7.1 During performance of this practice and during normal operation of walk-through metal detectors, every attempt should be made to ensure that the operating environment remains constant. Architectural and electrical alterations and movement or relocation of metal chairs, tables, etc, near the detector may adversely affect the detection sensitivity and the detection pattern established by this practice. Large swings in temperature or humidity, or both, may also cause significant changes in sensitivity. Electromagnetic energy emitting devices should not be used or operated near the detector, particularly devices that are used intermittently such as radio transmitters.



## 8. Apparatus and Preparation

8.1 *Wooden Dowel*, or similar nonconductive/nonmagnetic rod—Using tape or other means, attach the test object to a 2-m (6-ft) wooden dowel or similar nonconductive/nonmagnetic rod. If the test object is orientation sensitive, position it so that it will be in the desired orientation for testing.

8.2 *Grids*, Using tape, string, or similar nonconductive/nonmagnetic material, construct identical grids stretching across the entry and exit planes of the detection zone similar to that shown in Fig. 2. The figure is an example of a 4 by 9 grid (36 elements). The use of an exit grid is very important to ensure the test object stays within the test path bounds and passes straight through the detection zone.

NOTE 3—This procedure assumes that operators of programmable metal detectors have determined the program that best fits their operation. If not, this procedure in an abbreviated form can be used to determine the appropriate program for specified test objects. Do this by testing all orthogonal orientations of the test objects in, at least, the center two columns of the test grid using the appropriate method described in Section 10 of this practice. Any unusual detection characteristics associated with test objects and programs will likely be identifiable from the data obtained in the center columns.

8.3 Refer to Appendix X3. This blank map form suggests some information that may be useful to have on record or on hand during testing. The operator should determine what entries are appropriate for his detector and method of operation. If applicable, fill in the requested information below the detection sensitivity map.

8.4 Ensure that the operating environment is typical of that during normal operations.

## 9. Prerequisites

9.1 Ensure the area around the detector contains all materials normally present; no material shall be removed purely for performance of this procedure.

9.2 Radios, pagers, and other electronic equipment that are not part of the building or security system should be at least 3 m (10 ft) away.

9.3 Energize all equipment located within 10 m (33 ft) of the detector that is normally “on” during routine operation.

## 10. Procedure

### 10.1 *Detectors with Sensitivity Settings Only:*

10.1.1 Set the sensitivity control to the least sensitive setting.

10.1.2 Select a grid element.

NOTE 4—The order in which the elements are tested (random or systematic) is at the tester’s discretion. Random testing is preferred by many operators.

10.1.3 Position the test object about 0.5 m (18 in.) in front of the grid element delineating the test path with the rod perpendicular to the vertical plane of the detector. Rotate the test object to the desired orientation.

NOTE 5—Test time can be greatly reduced by initially determining the critical orientation and then using this critical orientation for the mapping procedure instead of mapping all orientations for each detector. However, at least one detector of the type in use should be fully mapped using all orientations to ascertain the worst-case orientation and any anomalies or unusual detection characteristics associated with test object orientation.

The worst-case orientation for any single element may not be the same for other elements throughout the detection zone.

10.1.4 Keeping the rod perpendicular to the vertical plane of the detector, pass the test object through the detection zone on the selected test path to the other side of the portal aperture at a rate of 0.5 to 1.3 m/s (1.5 to 4.25 ft/s). While any velocity chosen from this range is suitable for testing, care should be exercised to maintain a consistent velocity throughout the entire mapping procedure. The test object should be passed through the detection zone in a smooth continuous motion.

NOTE 6—Test passes should be performed in the same direction as the direction of travel in normal usage. In cases of bidirectional usage, passes should be performed in both directions to determine the worst-case direction and element. In order to obtain consistent data, a point must be selected as a reference or target for alarm occurrence. The exit plane of the portal is used as the reference in this procedure. Alarms must occur before the test object exits this plane.

NOTE 7—Some operators have screening procedures that require the person being screened to pause in the detection zone. It is not necessary to attempt to duplicate the screening process by incorporating a pause.

10.1.5 If the detector fails to alarm on the first pass or the alarm occurred after the test object exited the portal, increase the sensitivity and reintroduce the test object as just described. Repeat this process until an alarm is generated on 10 consecutive passes. The lowest sensitivity setting resulting with 10 consecutive alarms is the critical sensitivity setting for the element (and orientation). Record this value in the appropriate element on Fig. 2.

NOTE 8—It may be possible to shortcut the testing regimen by initial trial and error testing to find the approximate threshold of detection for the element. Once the threshold is known, regimented testing can be used to determine the critical sensitivity setting for the element. Prior to using a shortcutting method it is recommended that tests be performed to verify that the shortcut method results in the same critical sensitivity settings as the regimented approach.

NOTE 9—If using a clean tester as described in Appendix X1, start the test passes from the normal operational queuing point.

NOTE 10—Most detectors have a fairly definite alarm threshold. Once familiarity is gained with individual detectors it may be possible to confidently reduce the number of test passes. This is left to the discretion of the operator.

NOTE 11—Some selected test objects in some test elements may not produce consistent alarms even at the full sensitivity setting. In some case, detectors may reach a false alarm threshold before consistent detection is realized in all elements. These operating limitations may have to be tolerated. Options that may alleviate or eliminate these conditions are changing detector make or model or changing programs on programmable detectors.

10.1.6 Proceed to test each grid element in the same manner as the first using the same orientation of the test object. Do this for all elements of the testing grid.

NOTE 12—When complete, the detection zone sensitivity map describes the metal detection pattern for the specific metal detector tested, the specified test object, the particular test object orientation, and the location of the detector. The detection zone sensitivity pattern is described by the relative values of the sensitivity settings and allows identification of the critical test element(s) for use when adjusting detector sensitivity (see Practice C 1269) and evaluating detector performance.

10.1.7 If applicable, perform 10.1.1 through 10.1.6 for each orthogonal orientation.

10.2 *Detectors with Numeric Readout:*



NOTE 13—The readout must be representative of the detector's sensitivity to the test object and directly correlates to its ability to produce metal detection alarms.

10.2.1 Set the sensitivity control to a level such that the response level is high enough to provide a good signal to noise ratio AND not saturate the detector at any test location.

10.2.2 Select a grid element (see Note 4).

10.2.3 Position the test object about 0.5 m (18 in.) in front of the grid element delineating the test path with the rod perpendicular to the vertical plane of the detector. Rotate the test object to the desired orientation (see Note 5).

10.2.4 Keeping the rod perpendicular to the vertical plane of the detector, pass the test object through the detection zone on the selected test path to the other side of the portal aperture at a rate 0.5 to 1.3 m/s (1.5 to 4.25 ft/s). The test object should pass through the portal aperture to the other side of the detection zone in a smooth continuous motion and at the same rate on each pass. Record the peak value generated during the test pass (see Note 6 and Note 7).

10.2.5 Perform a total of 10 test passes, recording the peak reading shown on the meter/counter on each pass. Record all values.

NOTE 14—If using a clean tester as described in Appendix X1, start the test passes from the normal operational queuing point.

NOTE 15—If the detector has a narrow and consistent response band it may be possible to confidently reduce the number of test passes. This is left to the discretion of the operator.

10.2.6 Calculate the mean for the 10 detection values and record it in the appropriate element on the detection sensitivity map (Fig. 2).

10.2.7 Proceed to test each grid element in the same manner as the first using the same orientation of the test object. Do this for all elements of the testing grid.

NOTE 16—When complete, the detection sensitivity map describes the in-plant metal detection pattern for the specific metal detector tested, the specified test object, and the particular test object orientation. The detection pattern is described by the relative sensitivity values (sensitivity settings or numeric values) and allows identification of the critical test element(s) for use when adjusting detector sensitivity and evaluating detector performance.

10.2.8 If applicable, perform 10.1.4 through 10.2.7 for each orthogonal orientation.

NOTE 17—If this procedure is used to select a test object from a group of test objects, repeat the process described by Section 10.1 or 10.2, as applicable, for each test object. Be sure the orientation and test passage method is duplicated (as nearly as possible) for each object. Use a new detection sensitivity map for each test object. The test object from the group that has the highest critical sensitivity setting or the numeric equivalent is the critical test object for that group.

## 11. Keywords

11.1 entry control; metal detection; metal detector; physical security; personnel screening; special nuclear material; walk-through metal detector

## APPENDIXES

### (Nonmandatory Information)

#### X1. ADDITIONAL INFORMATION

X1.1 *Test Objects*—Testing demonstrated that walk-through metal detectors made by different manufacturers do not necessarily respond identically to the same test sources. The responses can be widely diverse and unpredictable. Furthermore, unique detector responses to different types of metal render simulated test objects, such as a shaped metal block, unreliable for setting up and testing metal detectors. Because of these shortcomings, using actual weapons and appropriately shaped shielding materials appears to be the most reasonable approach, even though only a small percentage of the possible items and configurations of interest can reasonably be tested.

X1.2 *Alternate Methods for Developing Detection Sensitivity Maps:*

X1.2.1 Several methods are acceptable for developing detection sensitivity maps, the primary difference being the means of conveyance of the test object through the detection zone. The ideal method uses a purely mechanical means to convey the test object; the speed and path of the test object can be accurately controlled and repeated, thus reducing to a minimum the number of variables that affect detection. However, it is seldom practical to set up large jigs or mechanical apparatus in field locations, and extreme accuracy is not

necessary for field installation testing. A practical field method, the method described by this practice, uses a nonconductive/nonmagnetic rod with a test object attached to one end being manipulated by a person to introduce the test object into the detection zone. This method of conveyance, combined with physically delineating the test points with a grid constructed of tape or string, is reasonably accurate and repeatable. A third method, which is subject to many variables, has a person carry the test object through the detection zone. This practice describes only the second method but walk-through metal detector operators may use a method of their choosing.

X1.2.2 This practice describes two means for valuing the detection sensitivity map grid elements. The first uses the sensitivity setting of the metal detector controller to derive the critical sensitivity setting for each test element. This method, which uses the numeric setting of the controller as the value for detection, is compatible with all known detectors currently on the market. This practice also describes a method compatible with detectors having a means of providing numeric data representative of the detection function. These are expected to be introduced to the market in the future. The value of the numeric readout produced by the test object is used in place of



the sensitivity setting on the detection sensitivity map. However, the operator must be certain that the readout is actually representative of the detection capability of the detector. Modern programmable detectors often measure attributes other than the amplitude of the signal produced by a test object and

these must be represented in the numeric readout. Use caution if attempting to tap an existing detector to get numeric data. It is strongly recommended that manufacturers be contacted for proper setup techniques; assumption on how certain circuits operate may not be valid.



## X2. IN-PLANT WALK-THROUGH METAL DETECTOR TESTING PROGRAM

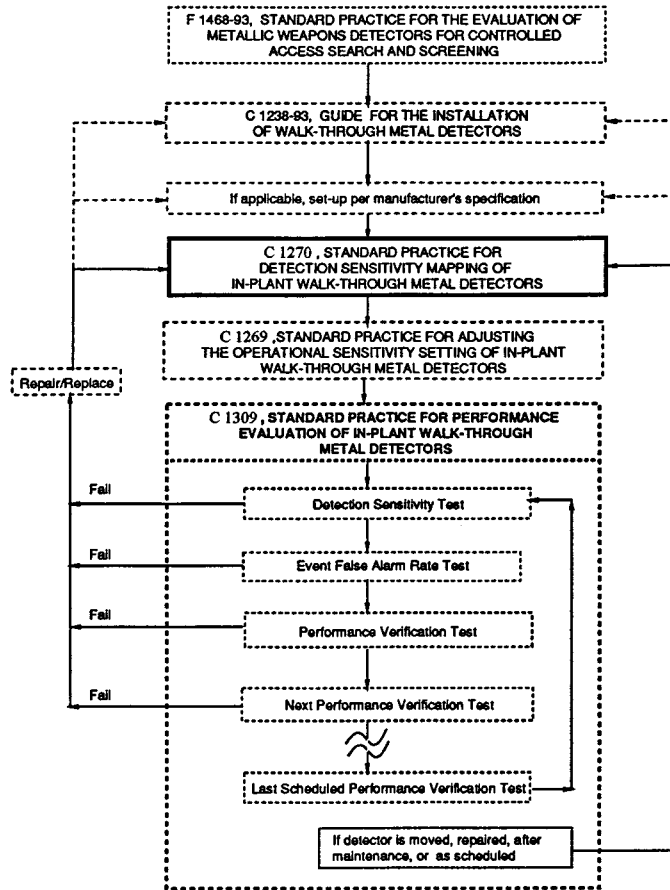

FIG. X2.1 Procedures for In-Plant Walk-Through Metal Detector Program





**X3. FORM—DETECTION SENSITIVITY MAP**

NOTE X3.1—Important: Ensure the location of the transmitter and receiver are identified. If the detector does not have a dedicated transmitter and receiver, note the side from which testing is performed relative to the protected area.

1	2	3	4
5	6	7	8
9	10	11	12
13	14	15	16
17	18	19	20
21	22	23	24
25	26	27	28
29	30	31	32
33	34	35	36

Manufacturer: \_\_\_\_\_      Weapon Test Object ID No.: \_\_\_\_\_  
 Model: \_\_\_\_\_              Shielding Test Object ID No.: \_\_\_\_\_  
 Date Tested: \_\_\_\_\_        Tester sign: \_\_\_\_\_  
 Location: \_\_\_\_\_            Verification sign.: \_\_\_\_\_  
 Parameter Settings: \_\_\_\_\_      Orientation: \_\_\_\_\_

*ASTM International takes no position respecting the validity of any patent rights asserted in connection with any item mentioned in this standard. Users of this standard are expressly advised that determination of the validity of any such patent rights, and the risk of infringement of such rights, are entirely their own responsibility.*

*This standard is subject to revision at any time by the responsible technical committee and must be reviewed every five years and if not revised, either reapproved or withdrawn. Your comments are invited either for revision of this standard or for additional standards and should be addressed to ASTM International Headquarters. Your comments will receive careful consideration at a meeting of the responsible technical committee, which you may attend. If you feel that your comments have not received a fair hearing you should make your views known to the ASTM Committee on Standards, at the address shown below.*

*This standard is copyrighted by ASTM International, 100 Barr Harbor Drive, PO Box C700, West Conshohocken, PA 19428-2959, United States. Individual reprints (single or multiple copies) of this standard may be obtained by contacting ASTM at the above address or at 610-832-9585 (phone), 610-832-9555 (fax), or service@astm.org (e-mail); or through the ASTM website (www.astm.org).*