



Designation: C 1346 – 9602

## Standard Practice for Dissolution of UF<sub>6</sub> from P-10 Tubes<sup>1</sup>

This standard is issued under the fixed designation C 1346; the number immediately following the designation indicates the year of original adoption or, in the case of revision, the year of last revision. A number in parentheses indicates the year of last reapproval. A superscript epsilon ( $\epsilon$ ) indicates an editorial change since the last revision or reapproval.

### 1. Scope

1.1 This practice covers the dissolution of UF<sub>6</sub> from a P-10 tube to provide solutions for analysis.

1.2 *This standard does not purport to address all of the safety concerns, if any, associated with its use. It is the responsibility of the user of this standard to establish appropriate safety and health practices and determine the applicability of regulatory limitations prior to use.* For specific safeguard and safety precaution statements, see Section 8.

### 2. Referenced Documents

2.1 *ASTM Standards:*

---

<sup>1</sup> This practice is under the jurisdiction of ASTM Committee C-26 on Nuclear Fuel Cycle and is the direct responsibility of Subcommittee C26.05 on Methods of Test. Current edition approved July 10, 1996; 2002. Published September 1996; April 2002. Originally published as C 1346-96. Last previous edition C 1346-96

C 761 Test Methods for Chemical, Mass Spectrometric, Spectrochemical, Nuclear, and Radiochemical Analysis of Uranium Hexafluoride<sup>2</sup>  
 C 787 Specification for Uranium Hexafluoride for Enrichment<sup>2</sup>

**3. Summary of Practice**

3.1 UF<sub>6</sub> samples intended for analysis are packaged in P-10 tubes to prevent sublimation and reaction with moisture in the air. The P-10 tube assembly (Fig. 1) consists of a fluorothene tube containing the UF<sub>6</sub>, a fluorothene gasket to cover the tube's opening, and a Monel nut and plug to seal the gasket to the tube.

3.2 The UF<sub>6</sub> tube is weighed, cooled in liquid nitrogen, and quickly opened and immersed in ice-cold water for dissolution. The pieces of the tube's assembly are removed from the resulting solution, rinsed, dried, reassembled, and weighed. The solution is dried for gravimetric conversion to U<sub>3</sub>O<sub>8</sub>, or diluted to an appropriate concentration for dispensing into aliquants for subsequent analysis.

**4. Significance and Use**

4.1 Uranium hexafluoride is a basic material used to prepare nuclear reactor fuel. To be suitable for this purpose the material must meet criteria for uranium content, isotopic composition, metallic impurities, hydrocarbon, and partially substituted halohydrocarbon content in Specification C 787. This practice results in the complete dissolution of the sample for uranium and impurities analysis, and determination of isotopic distribution by thermal ionization mass spectrometry as described in Test Methods C 761. Highly volatile impurities should be determined directly on UF<sub>6</sub>.

**5. Apparatus**

- 5.1 Steam bath, in a hood, if optional step 9.2.13 is used.
  - 5.2 Vacuum oven, if option 2 of 9.2.16 is used. The oven should be adjustable to 80°C at a pressure of -29 in. of Hg.
  - 5.3 Dewar flask, wide-mouth.
  - 5.3 ~~Vise, small lab-bench model.~~
  - 5.4 Aluminum foil. Vise, small lab-bench model or similar type of holder.
  - 5.5 Wrenches, 2.4 cm (15/16 in.) in.
  - 5.6 Plastic clamping forceps, 12 to 13 cm long, with a straight tip.
  - 5.7 Plastic clamping forceps, 12 to 13 cm long, with a claw-like bent tip, to securely hold the cylindrical fluorothene tube.
- NOTE 1—These forceps are not commercially available. Bend the ends of a straight-tip forceps by heating over a moderate flame, shaping, and maintaining the shape until cool.
- 5.8 Lint free tissues.
  - 5.9 ~~—~~
  - 5.7 TFE-fluorocarbon-coated spatula, 0.5- to 1-cm wide at its flat end, optional.
  - 5.10 Platinum or fluorothene rod, optional.
  - 5.11 Watch glasses, plastic, two per sample (one to fit platinum dishes and one to hold tube components).
  - 5.12 ~~—~~
  - 5.9 Platinum dishes, 250-mL.

<sup>2</sup> Annual Book of ASTM Standards, Vol 12.01.

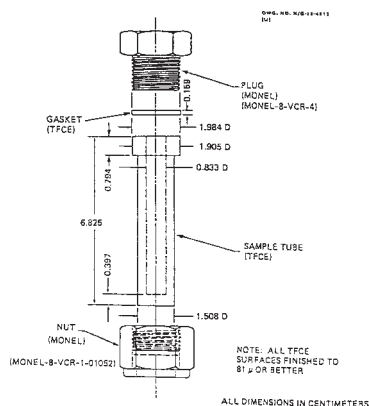

NOTE 1—This figure is from page 10 of the reference in Footnote 4.

**FIG. 1 P-10 Sample Tube**

~~5.13 Funnels, plastic.~~

~~5.14 Gloves, for use with bulk quantities of cryogenic substances.~~

~~5.15 Face shield or goggles.~~

~~5.16 Gloves, surgical.~~

~~5.17 Gloves, thin-cotton or equivalent, two pairs.~~

~~5.18 large enough to contain a completely submerged P-10 tube.~~

5.10 Copper wires, optional. The wires should be flexible and looped at one end to loosely fit around the fluorothene tube without allowing the Monel flare nut to pass through.

~~5.191 Desiccator.~~

~~5.20 Graduated cylinder, 100-mL.~~

~~5.21 optional.~~

5.12 Balance,  $\geq 100$ -g capacity, readable to at least 0.1 mg, preferably 0.01 mg, internal weight density of 8.0 g/cm<sup>3</sup>.

NOTE 2—Use of a balance with lower sensitivity will negatively impact on sampling error.

## 6. Interferences

6.1 The weight of the fluorothene tube is affected by atmospheric humidity. Keep the P-10 tube assembly in a desiccator between weighings until constant weight is attained.

6.2 The capacity of the UF<sub>6</sub> tube (a maximum of approximately 13.0 g UF<sub>6</sub>) limits the number and size of the aliquants that can be obtained from each tube. See analytical procedures for their requirements.

## 7. Reagents

7.1 *Purity of Reagents*—Reagent grade chemicals shall be used in all tests. Unless otherwise indicated, it is intended that all reagents conform to the specifications of the Committee on Analytical Reagents of the American Chemical Society where such specifications are available.<sup>3</sup> Other grades of reagents may be used, provided it is first ascertained that the reagent is of sufficiently high purity to permit its use without lessening the accuracy of the determination.

7.2 *Purity of Water*—Unless otherwise indicated, references to water shall be understood to mean laboratory-accepted demineralized or deionized water.

7.3 Liquid nitrogen.

7.4 Water, deionized distilled, cooled to about 4°C, approximately 100 mL per sample.

7.5 Ethanol or other suitable, volatile organic solvent.

## 8. Hazards

8.1 Since UF<sub>6</sub> materials are radioactive, toxic, and highly reactive, especially with reducing substances and moisture, adequate laboratory facilities and fume hoods along with safe techniques must be used in handling samples containing these materials. A detailed discussion of all necessary precautions is beyond the scope of this practice. However, personnel who handle radioactive materials should be familiar with the safe handling practices of the facility.

8.2 Follow all safety procedures for handling uranium and UF<sub>6</sub> provided by the facility. Review the Material Safety Data Sheet (MSDS) for UF<sub>6</sub> prior to performing the procedure.

8.3 Perform dissolutions in a laboratory hood. Hoods should be regularly inspected for proper air flow.

8.4 Gaseous UF<sub>6</sub>, when released to the atmosphere, reacts with moisture to form HF gas and UO<sub>2</sub>F<sub>2</sub> particulate (a white amorphous solid that settles on all surfaces). Release of UF<sub>6</sub> to the atmosphere is readily visible as a white cloud. The corrosive nature of HF and UF<sub>6</sub> can cause skin burns and lung impairment. Medical evaluation is mandatory for all situations where there may have been inhalation or contact with HF or UF<sub>6</sub>. Water soluble UO<sub>2</sub>F<sub>2</sub>, when inhaled or ingested in large quantities, is toxic to the kidneys.

8.5 Use gloves designed for use with cryogenic substances, and wear goggles or a face shield when handling bulk quantities of liquid nitrogen.

## 9. Procedure

9.1 *Preparation:*

9.1.1 Check the appearance of the UF<sub>6</sub> P-10 tube. Reject the tube if it exhibits discoloration of the contents. Wipe the outside of the tube with a ~~damp~~ lintless tissue moistened with a suitable, volatile organic solvent (for example, ethanol) and allow to ~~air-dry.~~

~~9.1.2 Place air-dry. Allow the tube to stand overnight to equilibrate with room air, or place the P-10 tube in a desiccator for at least one hour to remove water adsorbed on the surface of the tube. Using hour.~~

<sup>3</sup> *Reagent Chemicals, American Chemical Society Specifications*, American Chemical Society, Washington, DC. For suggestions on the testing of reagents not listed by the American Chemical Society, see *Analar Standards for Laboratory Chemicals*, BDH Ltd., Poole, Dorset, U.K., and the *United States Pharmacopeia and National Formulary*, U.S. Pharmaceutical Convention, Inc. (USPC), Rockville, MD.

9.1.2 Using a 4- or 5- decimal place balance, weigh the sample tube until to constant weight is achieved. (Store the tube in the desiccator between weighings.) weight. Identify the last this initial mass weight as  $W_g$ .

9.1.3 To slow down the reduce any loss of liquid nitrogen during the dissolution procedure, the Dewar flask and the P-10 tube may be cooled in a refrigerator prior to use (optional).

9.2 *Dissolution:*

9.2.1 Wearing cryogenic gloves and a face shield or goggles, fill the Dewar with liquid nitrogen and place it in the hood, covering hood and cover with a lid such as aluminum foil during transport.

9.2.2 *Option 1*—Slip the P-10 tube into a loop of copper wire. Holding on to the end of the wire, lower the tube into the liquid nitrogen without submerging the Monel fittings. Secure the wire by bending it over the top edge of the Dewar flask. Cover the Dewar flask with aluminum foil or other suitable covering.

9.2.3 *Option 2*—Submerge the entire P-10 tube into the liquid nitrogen. Cover the Dewar flask with aluminum foil or other suitable covering.

9.2.4 Leave the tube suspended in liquid nitrogen for at least ten minutes. Immediately before removing the tube, pour a minimum of approximately 50 – 100 mL ice-cold (approximately 4°C) distilled deionized water into a graduated cylinder. platinum dish.

NOTE 3—The volume of ice-cold distilled deionized water must be sufficient to cover the opening in the P-10 tube.

NOTE 4—For steps 9.2.45 through 9.2.89, try to minimize elapsed time while maximizing care in handling.

9.2.4 Wearing three pairs of

9.2.5 Wearing cryogenic gloves (surgical first, followed by two layers of cotton gloves), use the suspending wire to remove the P-10 tube from the Dewar liquid nitrogen. Quickly position the tube vertically in the vise, with the Monel fittings on top. Tighten the vise around the nut.

9.2.5 Use top.

9.2.6 Use a wrench to loosen the Monel plug. Remove the plug and place it in a stainless steel beaker or plastic dish or on a plastic watch glass.

9.2.6 With the cover.

9.2.7 Gently push (the flat end of a TFE-fluorocarbon spatula, gently push may be used) the fluorothene tube upward through the nut until just enough of the tube emerges to securely grasp the fluorothene tube with tube. Hold the bent tips of the clamping forceps. Set aside the TFE-fluorocarbon spatula; hold the gasket gently but firmly in place with a gloved index finger.

9.2.78 Pull the tube through its Monel nut, and lay it on its side in a platinum dish. Release tube and gasket from dish containing the clamping forceps and finger.

9.2.8 Immediately cover the tube and gasket with ice-cold (approximately 4°C) distilled, deionized-distilled water. A Either a platinum or fluorothene rod and bent-tip forceps, or the rod alone, or the forceps alone may be used, as necessary, to dislodge the gasket, if necessary, gasket and to encourage facilitate the flow of water into the tube.

9.2.9 Remove the nut from the holder and place it in the stainless steel beaker or plastic dish with a second or on the plastic cover with the plug.

9.2.10 With the tips of the bent-tips forceps partially opened, push the gasket up on the wall of the platinum dish. As the gasket emerges above the solution, grasp it securely with the forceps.

9.2.11 Carefully rinse the gasket and forceps with distilled deionized water into the solution and place the gasket in the stainless steel beaker or plastic dish or on the plastic cover with the Monel fittings.

9.2.12 Place the platinum dish in the hood for at least another 3 2–4 h until to ensure that dissolution is complete. (Dissolution is complete when yellow solution completely fills the tube.) Remove the nut from the vise and place it A plastic cover may be placed on the first watch glass with the plug. (All gloves may platinum dish at this time.

NOTE 5—Steps 9.2.13 and 9.2.14 are optional, but if one is done, both must be removed.)

9.2.10 After done.

9.2.13 After dissolution appears to be complete, place the platinum dish (with tube and gasket) tube) on a steam bath for 1 h to reduce the volume of solution and ensure complete hydrolysis.

9.2.14 Remove the platinum dish from the steam bath and allow to cool to ambient temperature.

9.2.12 Using the bent-tip clamping forceps;

9.2.15 After dissolution appears to be complete, carefully remove the empty tube from the solution using either the bent-tip clamping forceps or fluorothene rod, as appropriate, with deionized distilled deionized water into the solution. Do not splash. Place the tube in the stainless steel beaker or plastic dish or on the first watch glass plastic cover with nut and plug.

9.2.13 With the tips of the bent-tip forceps partially opened, push the gasket up the wall of the platinum dish. As the gasket emerges above the solution, grasp it securely with the straight-tip forceps. Leave the bent-tip forceps resting against the inside wall of the platinum dish.

9.2.14 Rinse the gasket carefully into the solution Monel fittings and place it on gasket.

9.2.16 *Option 1*—Allow the watch glass with the tube.

9.2.15 Rinse both forceps carefully into the solution.

~~9.2.16~~ Allow the emptied tube to air-dry overnight. Place the parts in a desiccator for at least one hour to remove adsorbed water, then reassemble.

~~9.2.17~~ Weigh

~~9.2.17 Option 2~~—Place the P-10 tube in a vacuum oven at 80°C and at -29 in. Hg for 2 h. Remove the P-10 tube parts from the vacuum oven and allow the tube to come to ambient temperature (2 h minimum), then reassemble.

~~9.2.18~~ Weigh the tubeto constant weight using the same balance as in 9.1.2 until constant weight is achieved. Record all weights and times taken. ~~weights.~~ Identify the last final weight as  $W_f$ . Store tube in a desiccator between readings.

~~9.2.18~~ The

~~9.2.19~~ The solution from 9.2.15 may either be dried for gravimetric conversion to  $U_3O_8$ , or transferred to an appropriate container for dilution and subsampling for chemical or isotopic analysis.

## 10. Calculations

10.1 Buoyancy Corrections:

10.1.1 Weight of  $UF_6$  dissolved ( $W_c$ ), corrected for air buoyancy and cover gas, in grams.<sup>4,5</sup>

$$W_c = (-0.0058) + (1.00047) (W_g - W_f) \quad (1)$$

where:

$W_g$  = weight of P-10 tube containing  $UF_6$ , in grams, and

$W_f$  = weight of empty P-10 tube, in grams.

NOTE ~~46~~—This buoyancy correction applies to the sample tube in Fig. 1. The constants in the equation may differ for different sample tubes.

## 11. Keywords

11.1 dissolution; P-10 tube; uranium hexafluoride; uranium hexafluoride dissolution

<sup>4</sup> Hedge, W. D., "Empirical Cover Gas Correction, Sample Freezing Time, and Air Buoyancy Adjustment for the Analysis of Uranium in Uranium Hexafluoride," *Report K-2051*, Oak Ridge Gaseous Diffusion Plant, Martin Marietta Energy Systems, Inc., Oak Ridge, TN, July 31, 1985.

<sup>5</sup> Hedge, W. D., "Composite Net  $UF_6$  Weight Data," Martin Marietta Energy Systems, Inc., Oak Ridge Gaseous Diffusion Plant, ANALIS correspondence to R. E. Simmons, Paducah Gaseous Diffusion Plant; H. H. Sullivan, Oak Ridge Gaseous Diffusion Plant; and O. A. Vita, Goodyear Atomic Corporation, May 28, 1986.

*ASTM International takes no position respecting the validity of any patent rights asserted in connection with any item mentioned in this standard. Users of this standard are expressly advised that determination of the validity of any such patent rights, and the risk of infringement of such rights, are entirely their own responsibility.*

*This standard is subject to revision at any time by the responsible technical committee and must be reviewed every five years and if not revised, either reapproved or withdrawn. Your comments are invited either for revision of this standard or for additional standards and should be addressed to ASTM International Headquarters. Your comments will receive careful consideration at a meeting of the responsible technical committee, which you may attend. If you feel that your comments have not received a fair hearing you should make your views known to the ASTM Committee on Standards, at the address shown below.*

*This standard is copyrighted by ASTM International, 100 Barr Harbor Drive, PO Box C700, West Conshohocken, PA 19428-2959, United States. Individual reprints (single or multiple copies) of this standard may be obtained by contacting ASTM at the above address or at 610-832-9585 (phone), 610-832-9555 (fax), or service@astm.org (e-mail); or through the ASTM website (www.astm.org).*