



Designation: C 698 – 98

Standard Test Methods for Chemical, Mass Spectrometric, and Spectrochemical Analysis of Nuclear-Grade Mixed Oxides ((U, Pu)O₂)¹

This standard is issued under the fixed designation C 698; the number immediately following the designation indicates the year of original adoption or, in the case of revision, the year of last revision. A number in parentheses indicates the year of last reapproval. A superscript epsilon (ε) indicates an editorial change since the last revision or reapproval.

1. Scope

1.1 These test methods cover procedures for the chemical, mass spectrometric, and spectrochemical analysis of nuclear-grade mixed oxides, (U, Pu)O₂, powders and pellets to determine compliance with specifications.

1.2 The analytical procedures appear in the following order:

	Sections
Uranium by Controlled-Potential Coulometry	2
Plutonium by Controlled-Potential Coulometry	2
Plutonium by Amperometric Titration with Iron (II)	2
Nitrogen by Distillation Spectrophotometry Using Nessler Reagent	7 to 14
Carbon (Total) by Direct Combustion-Thermal Conductivity	15 to 26
Total Chlorine and Fluorine by Pyrohydrolysis	27 to 34
Sulfur by Distillation-Spectrophotometry	35 to 43
Moisture by the Coulometric, Electrolytic Moisture Analyzer	44 to 51
Isotopic Composition by Mass Spectrometry	3
Rare Earths by Copper Spark Spectroscopy	52 to 59
Trace Impurities by Carrier Distillation Spectroscopy	60 to 69
Impurities by Spark-Source Mass Spectrography	70 to 76
Total Gas in Reactor-Grade Mixed Dioxide Pellets	77 to 84
Tungsten by Dithiol-Spectrophotometry	85 to 93
Rare Earth Elements by Spectroscopy	94 to 97
Plutonium-238 Isotopic Abundance by Alpha Spectrometry	98 to 105
Americium-241 in Plutonium by Gamma-Ray Spectrometry	
Uranium and Plutonium Isotopic Analysis by Mass Spectrometry	106 to 114
Oxygen-to-Metal Atom Ratio by Gravimetry	115 to 123

1.3 *This standard does not purport to address all of the safety concerns, if any, associated with its use. It is the responsibility of the user of this standard to establish appropriate safety and health practices and determine the applicability of regulatory limitations prior to use.* (For specific safeguard and safety precaution statements, see Sections 11, 20, 64, and 120 and 110.6.1.)

2. Referenced Documents

2.1 ASTM Standards:

C 697 Test Methods for Chemical, Mass Spectrometric, and Spectrochemical Analysis of Nuclear-Grade Plutonium

¹ These test methods are under the jurisdiction of ASTM Committee C-26 on Nuclear Fuel Cycle and are the direct responsibility of Subcommittee C26.05 on Methods of Test.

Current edition approved Feb. 10, 1998. Published June 1998. Originally published as C698 – 72. Last previous edition C698 – 92.

² Discontinued as of Nov. 15, 1992.

³ Discontinued as of May 30, 1980.

Dioxide Powders and Pellets⁴

C 833 Specification for Sintered (Uranium-Plutonium) Dioxide Pellets⁴

C 852 Guide for Design Criteria for Plutonium Gloveboxes
C 1009 Guide for Establishing a Quality Assurance Program for Analytical Chemistry Laboratories Within the Nuclear Industry

C 1068 Guide for Qualification of Measurement Methods by a Laboratory Within the Nuclear Industry

C 1108 Test Method for Plutonium by Controlled-Potential Coulometry

C 1128 Guide for Preparation of Working Reference Materials for Use in the Analysis of Nuclear Fuel Cycle Materials

C 1156 Guide for Establishing Calibration for a Measurement Method Used to Analyze Nuclear Fuel Cycle Materials

C 1165 Test Method for Determining Plutonium by Controlled-Potential Coulometry in H₂SO₄ at a Platinum Working Electrode⁴

C 1168 Practice for Preparation and Dissolution of Plutonium Materials for Analysis

C 1204 Test Method for Uranium in the Presence of Plutonium by Iron (II) Reduction in Phosphoric Acid Followed by Chromium (VI) Titration⁴

C 1206 Test Method for Plutonium by Iron (II)/Chromium (VI) Amperometric Titration⁴

C 1210 Guide for Establishing a Measurement System Quality Control Program for Analytical Chemistry Laboratories Within the Nuclear Industry

C 1268 Test Method for Quantitative Determination of Americium 241 in Plutonium by Gamma-Ray Spectrometry

C 1297 Guide for Qualification of Laboratory Analysts for the Analysis of Nuclear Fuel Cycle Materials

D 1193 Specification for Reagent Water⁵

E 60 Practice for Photometric and Spectrophotometric Methods for Chemical Analysis of Metals⁶

E 115 Practices for Photographic Processing in Optical

⁴ Annual Book of ASTM Standards, Vol 12.01.

⁵ Annual Book of ASTM Standards, Vol 11.01.

⁶ Annual Book of ASTM Standards, Vol 03.05.



Emission Spectrographic Analysis⁶
E 116 Practice for Photographic Photometry in Spectrochemical Analysis⁶

3. Significance and Use

3.1 Mixed oxide, a mixture of uranium and plutonium oxides, is used as a nuclear-reactor fuel in the form of pellets. The plutonium content may be up to 10 weight %, and the diluent uranium may be of any ²³⁵U enrichment. In order to be suitable for use as a nuclear fuel, the material must meet certain criteria for combined uranium and plutonium content, effective fissile content, and impurity content as described in Specification C 833.

3.1.1 The material is assayed for uranium and plutonium to determine whether the plutonium content is as specified by the purchaser, and whether the material contains the minimum combined uranium and plutonium contents specified on a dry weight basis.

3.1.2 Determination of the isotopic content of the plutonium and uranium in the mixed oxide is made to establish whether the effective fissile content is in compliance with the purchaser's specifications.

3.1.3 Impurity content is determined to ensure that the maximum concentration limit of certain impurity elements is not exceeded. Determination of impurities is also required for calculation of the equivalent boron content (EBC).

4. Reagents

4.1 *Purity of Reagents*—Reagent grade chemicals shall be used in all tests. Unless otherwise indicated, it is intended that all reagents shall conform to the specifications of the Committee on Analytical Reagents of the American Chemical Society, where such specifications are available.⁷ Other grades may be used, provided it is first ascertained that the reagent is of sufficiently high purity to permit its use without lessening the accuracy of the determination.

4.2 *Purity of Water*— Unless otherwise indicated, references to water shall be understood to mean reagent water conforming to Specification D 1193.

5. Safety Precautions

5.1 Since plutonium- and uranium-bearing materials are radioactive and toxic, adequate laboratory facilities, gloved boxes, fume hoods, etc., along with safe techniques must be used in handling samples containing these materials. A detailed discussion of all the precautions necessary is beyond the scope of these test methods; however, personnel who handle these materials should be familiar with such safe handling practices as are given in Guide C 852 and in Refs (1) through (3).⁸

5.2 *Committee C-26 Safeguards Statement*:⁹

⁷ "Reagent Chemicals, American Chemical Society Specifications," Am. Chem. Soc., Washington, DC. For suggestions on the testing of reagents not listed by the American Chemical Society, see "Reagent Chemicals and Standards," by Joseph Rosin, D. Van Nostrand Co., Inc., New York, NY, and the "United States Pharmacopeia."

⁸ The boldface numbers in parentheses refer to the list of references at the end of these test methods.

⁹ Based upon Committee C-26 Safeguards Matrix (C 1009, C 1068, C 1128, C 1156, C 1210, C 1297).

5.2.1 The materials [nuclear grade mixed oxides (U, Pu)O₂ powders and pellets] to which these test methods apply are subject to nuclear safeguards regulations governing their possession and use. The following analytical procedures in these test methods have been designated as technically acceptable for generating safeguards accountability measurement data: Uranium by Controlled Potential Coulometry; Plutonium by Controlled-Potential Coulometry; Plutonium by Amperometric Titration with Iron(II); Plutonium-238 Isotopic Abundance by Alpha Spectrometry; and Uranium and Plutonium Isotopic Analysis by Mass Spectrometry.

5.2.2 When used in conjunction with appropriate certified reference materials (CRMs), these procedures can demonstrate traceability to the national measurements base. However, adherence to these procedures does not automatically guarantee regulatory acceptance of the resulting safeguards measurements. It remains the sole responsibility of the user of these test methods to assure that its application to safeguards has the approval of the proper regulatory authorities.

6. Sampling and Dissolution

6.1 Criteria for sampling this material are given in Specification C 833.

6.2 Samples can be dissolved using the appropriate dissolution techniques described in Practice C 1168.

URANIUM IN THE PRESENCE OF PLUTONIUM BY POTENTIOMETRIC TITRATION

(This test method was discontinued in 1992 and replaced by Test Method C 1204.)

PLUTONIUM BY CONTROLLED POTENTIAL COULOMETRY

(This test method was discontinued in 1992 and replaced by Test Method C 1165.)

PLUTONIUM BY CONTROLLED-POTENTIAL COULOMETRY

(With appropriate sample preparation, controlled-potential coulometric measurement as described in Test Method C 1108 may be used for plutonium determination.)

PLUTONIUM BY AMPEROMETRIC TITRATION WITH IRON(II)

(This test method was discontinued in 1992 and replaced by Test Method C 1206.)

NITROGEN BY DISTILLATION SPECTROPHOTOMETRY USING NESSLER REAGENT

7. Scope

7.1 This test method covers the determination of 5 to 100 µg/g of nitride nitrogen in mixtures of plutonium and uranium oxides in either pellet or powder form.

8. Summary of Test Method

8.1 The sample is dissolved in hydrochloric acid by the sealed tube test method or by phosphoric acid-hydrofluoric

acid solution, after which the solution is made basic with sodium hydroxide and nitrogen is separated as ammonia by steam distillation. Nessler reagent is added to the distillate to form the yellow ammonium complex and the absorbance of the solution is measured at approximately 430 nm (4, 5).

9. Apparatus

9.1 *Distillation Apparatus* (see Fig. 1).

9.2 *Spectrophotometer*, visible-range.

10. Reagents

10.1 *Ammonium Chloride* (NH_4Cl)—Dry the salt for 2 h at 110 to 120°C.

10.2 *Boric Acid Solution* (40 g/litre)—Dissolve 40 g of boric acid (H_3BO_3) in 800 mL of hot water. Cool to approximately 20°C and dilute to 1 L.

10.3 *Hydrochloric Acid* (sp gr 1.19)—Concentrated hydrochloric acid (HCl).

10.4 *Hydrofluoric Acid* (sp gr 1.15)—Concentrated hydrofluoric acid (HF).

10.5 *Nessler Reagent*—To prepare, dissolve 50 g of potassium iodide (KI) in a minimum of cold ammonia-free water, approximately 35 mL. Add a saturated solution of mercuric chloride (HgCl_2 , 22 g/350 mL) slowly until the first slight precipitate of red mercuric iodide persists. Add 400 mL of 9 N sodium hydroxide (NaOH) and dilute to 1 L with water. Mix, and allow the solution to stand overnight. Decant the supernatant liquid and store in a brown bottle.

10.6 *Nitrogen, Standard Solution* (1 mL = 0.01 mg N)—Dissolve 3.819 g of NH_4Cl in water and dilute to 1 L. Transfer 10 mL of this solution to a 1-L volumetric flask and dilute to volume with ammonia-free water.

10.7 *Sodium Hydroxide* (9 N)—Dissolve 360 g of sodium hydroxide (NaOH) in ammonia-free water and dilute to 1 L.

10.8 *Sodium Hydroxide Solution* —(50%)—Dissolve NaOH in an equal weight of ammonia-free water.

10.9 *Water, Ammonia-Free*—To prepare, pass distilled water through a mixed-bed resin demineralizer and store in a tightly stoppered chemical-resistant glass bottle.

11. Precautions

11.1 The use of ammonia or other volatile nitrogenous compounds in the vicinity can lead to serious error. The following precautionary measures should be taken: (1) Clean all glassware and rinse with ammonia-free water immediately

prior to use, and (2) avoid contamination of the atmosphere in the vicinity of the test by ammonia or other volatile nitrogenous compounds.

12. Procedure

12.1 Dissolution of Sample:

12.1.1 Transfer a weighed sample, in the range from 1.0 to 1.5 g, to a 50-mL beaker.

NOTE 1—Pellet samples should be crushed to a particle size of 1 mm or less with a diamond mortar.

12.1.2 To the sample add 5 mL of HCl (sp gr 1.19) and 3 drops of HF (sp gr 1.15). Heat to put the sample into solution.

NOTE 2—Concentrated phosphoric acid or mixtures of phosphoric acid and hydrofluoric acids or of phosphoric and sulfuric acids may be used for the dissolution of mixed oxide samples. Such acids may require a purification step in order to reduce the nitrogen blank before being used in this procedure.

12.2 Distillation:

12.2.1 Quantitatively transfer the sample solution to the distilling flask of the apparatus. Add 20 mL of ammonia-free water and then clamp the flask into place on the distillation apparatus (see Fig. 2).

12.2.2 Turn on the steam generator but do not close with the stopper.

12.2.3 Add 5 mL of boric acid solution (4 %) to a 50-mL graduated flask and position this trap so that the condenser tip is below the surface of the boric acid solution.

12.2.4 Transfer 20 mL of NaOH solution (50 %) to the funnel in the distillation head.

12.2.5 When the water begins to boil in the steam generator, replace the stopper and slowly open the stopcock on the distilling flask to allow the NaOH solution to run into the sample solution.

NOTE 3—The NaOH solution must be added slowly to avoid a violent reaction which may lead to loss of sample.

12.2.6 Steam distill until 25 mL of distillate has collected in the trap.

12.2.7 Remove the trap containing the distillate from the distillation apparatus, and remove the stopper from the steam generator.

12.2.8 Transfer the cooled distillate to a 50-mL volumetric flask.

12.2.9 Prepare a reagent blank solution by following steps 12.1.1 through 12.2.8.

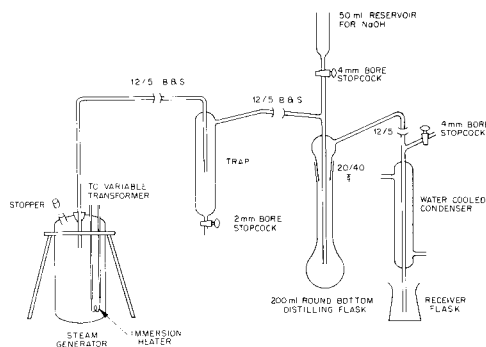

FIG. 1 Distillation Apparatus

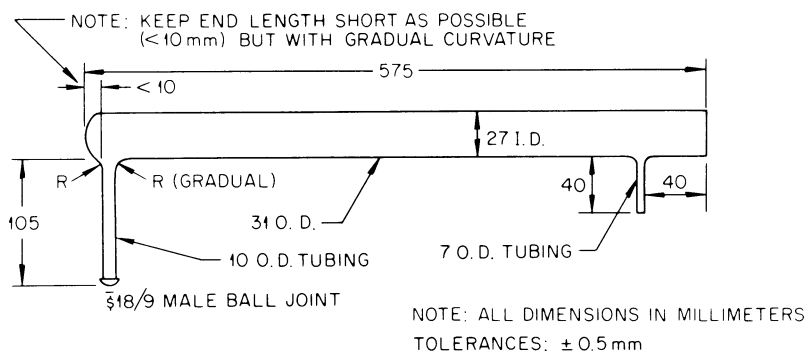

FIG. 2 Quartz Reaction Tube

12.3 Measurement of Nitrogen:

12.3.1 Add 1.0 mL of Nessler reagent to each of the distillates collected in 12.2.8 and 12.2.9. Dilute to volume with ammonia-free water, mix, and let stand for 10 min.

12.3.2 Measure the absorbance of the solutions at 430 nm in a 1-cm cell. Use water as the reference.

12.4 Calibration Curve:

12.4.1 Add 0, 5, 10, 25, 100, and 150 µg of nitrogen from the nitrogen standard solution to separate distilling flasks. Then, add 5 mL of HCl and 3 drops of HF plus 20 mL of ammonia-free water to each flask.

12.4.2 Process each solution by the procedure in 12.2 through 12.3 (omit step 12.2.9).

12.4.3 Correct for the reagent blank reading and plot the absorbance of each standard against micrograms of nitrogen per 50 mL of solution.

13. Calculation

13.1 From the calibration chart, read the micrograms of nitrogen corresponding to the absorbance of the sample solution.

13.2 Calculate the nitrogen content of the sample as follows:

$$N, \mu\text{g/g} = (A - B)/W \quad (1)$$

where:

A = micrograms of nitrogen from sample plus reagents,

B = micrograms of nitrogen in blank, and

W = grams of sample.

14. Precision and Bias

14.1 The estimated relative standard deviation for a single measurement by this test method is 20 % for 3 µg of nitrogen and 3 % for 50 to 90 µg of nitrogen.

CARBON (TOTAL) BY DIRECT COMBUSTION-THERMAL CONDUCTIVITY

15. Scope

15.1 This test method covers the determination of 10 to 200 µg of residual carbon in nuclear grade mixed oxides, (U,Pu)O₂.

16. Summary of Test Method

16.1 Powdered samples are covered and mixed with an accelerator in carbon-free crucibles and burned with oxygen in

an induction heating furnace. Traces of sulfur compounds and water vapor are removed from the combustion products by a purification train and the resultant carbon monoxide is converted to carbon dioxide. The purified carbon dioxide is trapped on a molecular sieve, eluted therefrom with a stream of helium upon application of heat to the trap, and passed through a thermal conductivity cell. The amount of carbon present, being a function of the integrated change in the current of the detector cell, is read directly from a calibrated-digital voltmeter or strip-chart recorder.

17. Interferences

17.1 There are no known interferences not eliminated by the purification system.

18. Apparatus

18.1 *Commercial Combustion Apparatus*, suitable for the carbon determination, is often modified to facilitate maintenance and operation within the glove box which is required for all work with plutonium materials.

18.2 *Combustion Apparatus*,¹⁰ consisting of an induction furnace, suitable for operation at 1600°C, a catalytic furnace, a purification train, a carbon dioxide trap, thermal conductivity cell with appropriate readout equipment, and a regulated supply of oxygen and helium.

18.3 *Combustion Tubes*— Quartz combustion tubes with integral baffle shall be used.

18.4 *Crucibles*—Expendable alumina or similar refractory crucibles shall be used. The use of crucible covers is optional. Satisfactory operation with covers must be established by analysis of standards. Crucibles and covers (if used) must be ignited at a temperature of 1000°C or higher for a time sufficient to produce constant blank values.

18.5 *Accelerators*— Granular tin, copper, iron, and copper oxide accelerators shall be used to obtain satisfactory results. The criterion for satisfactory results is the absence of significant additional carbon release upon recombustion of the specimen.

18.6 *Catalytic Furnace and Tube*—This unit, which is used to ensure complete conversion of CO to CO₂, consists of a tube containing copper oxide and maintained at a temperature of 300°C by a small furnace.

¹⁰ A Leco Low Carbon Analyzer, sold by Laboratory Equipment Co., St. Joseph, MI, or equivalent, has been found satisfactory for this purpose.

18.7 *Carbon Dioxide Purifiers*—The purifiers that follow the combustion tube must remove finely divided solid metallic oxides and oxides of sulfur and selenium, dry the gases before they enter the CO₂ trap, and protect the absorber from outside effects. Finely divided solid metal oxides are removed from the gases during their passage through the quartz wool. The SO₂ given off by materials containing sulfur is removed by MnO₂ and any water vapor is absorbed in a tube containing Mg(ClO₄)₂. Hot copper oxide converts carbon monoxide to carbon dioxide. Additional components in the purification train may be required when materials containing very high amounts of sulfur or of halides are being analyzed. The materials used in the purification train must be checked frequently to ensure that their absorbing capacity has not been exhausted.

18.8 *Vibratory Sample Pulverizer Apparatus*,¹¹ capable of reducing ceramic materials to a – 100-mesh powder. A stainless steel capsule and mixing ball must be used, in order to reduce contamination of the sample with carbon.

19. Reagents and Materials

19.1 *Quartz Wool*, used as a dust trap at the top of the combustion tube.

19.2 *Sulfuric Acid (H₂SO₄, sp gr 1.84)*, used in the oxygen purification train.

19.3 *Standard Materials*—National Institute for Standards and Technology (NIST) SRMs 131c (0.0029 % carbon) and 336 (0.567 % carbon) or their replacements.

20. Safety Precautions

20.1 *Samples Containing Plutonium*—Due to the extreme toxicity of plutonium and the certainty that some plutonium will become airborne during the analytical operations, it is mandatory to perform all operations within an approved glove box fitted with off-gas filters capable of sustained operation with dust-laden atmospheres.

20.2 *Samples Containing Uranium*—Natural or depleted uranium presents a somewhat less serious toxicological hazard than plutonium, but operations should be conducted in a fume hood with adequate ventilation, as a minimum precaution.

21. Sampling and Preparation

21.1 *Sample Size*—The normal size for mixed oxide [(U,Pu)O₂] fuel materials shall be 1 g. If necessary, this amount shall be altered as required to contain less than 200 µg of carbon.

21.2 *Sample Preparation*—Pellet or particulate samples shall be reduced to approximately – 100-mesh powder prior to the weighing of the specimens. Exposure of the powdered sample to atmospheric carbon dioxide should be minimized by storage of the powder in a closed vial.

22. Preparation of Apparatus

22.1 *Analysis System Purge*—After having properly set the operating controls of the instrument system, condition the apparatus by combustion of several blanks prepared with the

sample crucible and accelerator in the amount to be used with the test specimen analyses. Successive blank values should approach a constant value, allowing for normal statistical fluctuations. The instrument should be adjusted for a 2-min combustion period.

23. Calibration

23.1 *Preparation of Standards for Combustion*—Mix a weighed portion of an accelerator and a weighed portion of approximately 1 g of NIST 131c Low-Carbon Steel in each of the three sample crucibles. Repeat with NIST SRM 336 (Note 4), using approximately 30 to 40 mg.

NOTE 4—The NIST SRM 336 steel is assigned a carbon content of 0.567 % (5670 µg/g). Therefore, amounts ranging up to approximately 40 mg are used for standardization. Weigh the steel into a tared container (a small nickel sample boat if convenient), obtaining the mass to the nearest 0.01 mg. Transfer the chips to a 30-mm square of aluminum foil (previously acetone washed), and fold the foil into a wrapper with the aid of stainless steel tongs and spatulas. The foil should not be touched by the hands. Place the wrapped standard in a numbered glass sample vial and transfer to the analyzer glove box.

23.2 *Combustion of Standards*—Load and combust the standards and record the results. Adjust the calibration controls in such a way as to produce the correct readout value on the direct readout meter. Combust additional standards as required to produce the correct direct readout. As an alternative, consider the readout digits as arbitrary numbers and prepare a calibration curve of known micrograms of carbon *versus* readout value. A strip chart recorder connected to present the integrated value of the carbon dioxide response signal is helpful in detecting and correcting for analyzer drift and noise.

24. Procedure

24.1 Pulverize the pellet samples for 15 s in the stainless steel capsule of the sample pulverizer.

24.2 Weigh a sample crucible containing the required amount of accelerator to the nearest 0.01 g.

24.3 Transfer the sample powder, not to exceed 1 g or of such size as to give not more than 200 µg of carbon, to the crucible. Weigh the crucible and contents to the nearest 0.01 g and find the specimen mass by difference.

24.4 Mix the specimen powder and the accelerator with a stainless steel spatula.

24.5 Load the sample crucible into the furnace and combust the specimen for 2 min.

24.6 Remove the sample crucible and examine it for evidence of incomplete combustion. The crucible contents should be a uniform fused mass.

25. Calculation

25.1 Calculate the concentration of carbon in the sample by dividing the net micrograms of carbon found by the sample mass expressed in grams as follows:

$$C, \mu\text{g/g} = (C_s - C_b/W) \quad (2)$$

where:

C_s = carbon in sample and reagents, µg,
 C_b = carbon in reagent blank, µg, and
 W = grams of mixed oxide sample.

¹¹ Wig-L-Bug, sold by Spex Industries Inc., Scotch Plains, NJ, has been found satisfactory for this purpose.

26. Precision and Bias

26.1 *Precision*—The average standard deviation for a single measurement from the results of six laboratories is on the order of $10\mu\text{ g}$ carbon/g of sample.

26.2 *Bias*—The results obtained by six laboratories participating in a recent comparative analytical program averaged 85 % of the expected $100\mu\text{g/g}$ of carbon in the sample. The incomplete recovery is thought to represent a lack of experience on the part of two laboratories inasmuch as 95 to 100 % recovery was obtained by three of the participating laboratories.

TOTAL CHLORINE AND FLUORINE BY PYROHYDROLYSIS

27. Scope

27.1 This test method is applicable to the determination of 5 to $100\mu\text{ g/g}$ of chlorine and 1 to $100\mu\text{ g/g}$ of fluorine in 1-g samples of nuclear-grade mixed oxides, (U, Pu) O_2 .

28. Summary of Test Method

28.1 A 1 to 2-g sample of the mixed oxide is pyrohydrolyzed at 950°C with a stream of moist air or oxygen. The halogens are volatilized as acids during the pyrohydrolysis and are trapped as chloride and fluoride in a buffered solution. Several procedures are outlined for the measurement of chloride and fluoride in the resultant condensate. Chloride is measured by spectrophotometry, microtitrimetry, or with ion-selective electrodes and fluoride with ion-selective electrodes or spectrophotometry (6–9).

29. Interferences

29.1 Bromide, iodide, cyanide, sulfide, and thiocyanate, if present in the condensate, would interfere with the spectrophotometric and microtitrimetric measurement of chloride. Bromide, iodide, sulfide, and cyanide interfere in the measurement of chloride with ion-selective electrodes, but have very little effect upon the measurement of fluoride with selective electrodes.

30.

Apparatus (See Fig. 3 and Fig. 2)

30.1 *Gas-Flow Regulator*—A flowmeter and a rate controller are required to adjust the flow of sparge gas between 1 to 3 L/min.

30.2 *Hot Plate*—A heater used to keep the water bubbler temperature between 50 and 90°C is required.

30.3 *Furnace*—A tube furnace is required that is capable of maintaining a temperature from 900 to 1000°C . The bore of the furnace should be about 32 mm ($1\frac{1}{4}\text{ in.}$) in diameter and about 305 mm (12 in.) in length.

30.4 *Reactor Tube*, made from fused-silica or platinum. The delivery tube should be a part of the exit end of the reactor tube and be within 51 mm (2 in.) of the furnace. (See Fig. 3 for proper tube positioning.)

30.5 *Combustion Boats*, made from fused-silica or platinum. A boat about 102 mm (4 in.) long is made by cutting lengthwise a 20-mm diameter silica tube and flattening one end to provide a handle. A fused-silica inner sleeve for the reactor tube can facilitate the movement of the boat into the tube, prevent spillage, and thus prolong the life of the combustion tube.

30.6 *Collection Vessel*—A plastic graduate or beaker designed to maintain most of the scrubber solution above the tip of the delivery tube is required.

30.7 *Automatic Chloride Titrator*.¹²

30.8 *Ion-selective Electrodes*, chloride and fluoride.

30.9 *Reference Electrode*—Use a double-junction type such as mercuric sulfate, sleeve-junction type electrode. Do not use a calomel electrode.

30.10 *Spectrophotometer*—Ultraviolet to visible range and absorption cells. For a discussion on spectrophotometers and their use see Practice E 60.

30.11 *Meter, pH*, with expanded scale with a sensitivity of 1 mV .

31. Reagents

31.1 *Accelerator* (U_3O_8)—Halogen free U_3O_8 powder used as a flux to enhance the release of chloride and fluoride.

31.2 *Air or Oxygen*, compressed.

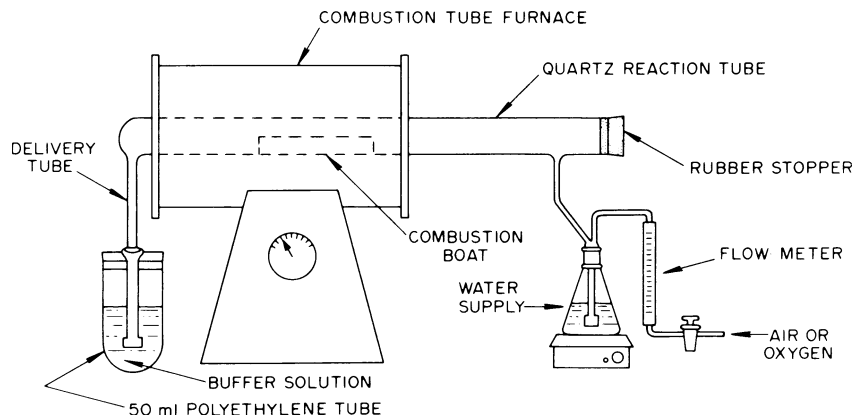

FIG. 3 Pyrohydrolysis Apparatus

¹² A Cotlov Titrator, sold by American Instrument Co., Silver Spring, MD, or by Buchler Instruments, Inc., Fort Lee, NJ, or equivalent, has been found satisfactory for this purpose.

31.3 *Buffer Solution (0.001 N Acetic Acid, 0.001 N Potassium Acetate)*—Prepare by adding 50 μL of glacial acetic acid ($\text{CH}_3\text{CO}_2\text{H}$, sp gr 1.05) and 0.10 g of potassium acetate ($\text{KC}_2\text{H}_3\text{O}_2$) to 1 L of water.

31.4 *Chloride Standard Solution (1 mL = 1 mg Cl)*—Dissolve 1.65 g of sodium chloride (NaCl) in water and dilute to 1 L.

31.5 *Chloride Standard Solution (1 mL = 5 μg Cl)*—Prepare by diluting 5 mL of chloride solution (1 mL = 1 mg Cl) to 1 L with water.

31.6 *Ferric Ammonium Sulfate (0.25 M in 9 M Nitric Acid)*—Dissolve 12 g of $\text{FeNH}_4(\text{SO}_4)_2 \cdot 12 \text{H}_2\text{O}$ in 58 mL of concentrated nitric acid (HNO_3 , sp gr 1.42) and dilute to 100 mL with water.

31.7 *Fluoride, Standard Solution (1 mL = 1 mg F)*—Dissolve 2.21 g of sodium fluoride (NaF) in water and dilute to 1 L.

31.8 *Fluoride, Standard Solution (1 mL = 10 μg F)*—Dilute 10 mL of fluoride solution (1 mL = 1 mg F) to 1 L with water.

31.9 *Gelatin Solution*—Add 6.2 g of dry gelatin mixture (60 parts of dry gelatin + 1 part of thymol blue + 1 part of thymol) to 1 L of hot water and heat while stirring until the solution is clear.

31.10 *Lanthanum-Alizarin Complexone*—Dissolve 0.048 g of alizarin complexone (3-aminomethylalizarin-*N,N*-diacetic acid) in 100 μL of concentrated ammonium hydroxide, 1 mL of an ammonium acetate solution ($\text{NH}_4\text{C}_2\text{H}_3\text{O}_2$, 20 mass %), and 5 mL of water. Filter the solution through high grade, rapid filter paper. Wash the paper with a small volume of water and add 8.2 g of anhydrous sodium acetate ($\text{NaC}_2\text{H}_3\text{O}_2$) and 6 mL of $\text{CH}_3\text{CO}_2\text{H}$ (sp gr 1.05) to the filtrate. Add 100 mL of acetone while swirling the filtrate. Add 0.040 g of lanthanum oxide (La_2O_3) dissolved in 2.5 mL of warm 2 N HCl. Mix the two solutions and dilute to 200 mL. After 30 min readjust the solution volume.¹³

NOTE 5—A 0.1-g/L solution of Amadac-F is prepared by dissolving 100 mg of the reagent in water and diluting with isopropyl alcohol to obtain a 60 % alcoholic medium.

31.11 *Mercuric Thiocyanate Solution*—Prepare a saturated solution by adding 0.3 g of mercuric thiocyanate [$\text{Hg}(\text{SCN})_2$] to 100 mL of ethanol (95 %). Shake the mixture thoroughly for maximum dissolution of the solid. Filter the solution.

31.12 *Nitric Acid-Acetic Acid Solution (1 N nitric acid and 4 N acetic acid)*—Prepare by adding 64 mL of nitric acid (HNO_3 , sp gr 1.42) to a 1-L volumetric flask which contains 500 mL of water. Swirl the solution in the flask and add 230 mL of $\text{CH}_3\text{CO}_2\text{H}$ (sp gr 1.05). Dilute the solution with water to 1 L.

32. Pyrohydrolysis Procedure

32.1 Prepare the pyrohydrolysis apparatus for use as follows:

32.1.1 Regulate the gas flow between 1 and 3 L/min.

32.1.2 Adjust the temperature of the hot plate to heat the water to approximately 90° C.

32.1.3 Adjust the temperature of the furnace to $950 \pm 50^\circ \text{C}$.

32.1.4 Add 15 mL of buffer solution to the collection vessel and place around the delivery tube.

32.2 Weigh accurately 1 to 2 g of the powdered mixed oxide and transfer to a combustion boat. If an accelerator, U_3O_8 , is used, mix 4 g with the sample before loading the powdered mixed oxide into the boat.

32.3 Place the boat containing the sample into the reactor tube and quickly close the tube. The boat should be in the middle of the furnace.

32.4 Allow the pyrohydrolysis to proceed for at least 30 min.

32.5 Remove the collection vessel and wash down the delivery tube with some buffer solution. Dilute the solution to 25 mL with the acetate buffer. Determine the chloride and fluoride by one or more of the measurement procedures covered in Section 60.

32.6 Remove the boat from the reactor tube and dispose of the sample residue.

32.7 Run a pyrohydrolysis blank with halogen-free U_3O_8 by following the procedure in 32.3 through 32.6.

33. Measurement of Chloride and Fluoride

33.1 *Determination of Chloride by Spectrophotometry:*

33.1.1 Prepare a calibration curve by adding 0, 1, 2, 5, and 10 mL of chloride standard solution (1 mL = 5 μg Cl) to separate 25-mL flasks. Dilute each to 20 mL with the buffer solution, add 2 mL of ferric ammonium sulfate solution and 2 mL of mercuric thiocyanate reagent. Mix the solution and dilute to 25 mL with water. Mix the solutions again and allow them to stand 10 min. Transfer some of the solution from the flask to a 1-cm absorption cell and read the absorbance at 460 nm using water as the reference liquid. Plot the micrograms of chloride per 25 mL versus the absorbance reading.

33.1.2 To determine the chloride in the pyrohydrolysis condensate transfer 15 mL of buffer solution to a 25-mL volumetric flask. Add 2 mL of ferric ammonium sulfate solution and 2 mL of mercuric thiocyanate solution. Mix the solutions, dilute to volume with water, and mix again. Allow the solution to stand 10 min. Transfer some of the solution from the flask to a 1-cm absorption cell and read the absorbance at 460 nm versus water as the reference. Read the micrograms of chloride present from the calibration curve.

NOTE 6—A calibration curve can be prepared by drying measured aliquots of a standard chloride solution on some halogen-free U_3O_8 and proceeding through pyrohydrolysis steps.

33.1.3 Calculate the chlorine as follows:

$$\text{Cl, } \mu\text{g/g} = [(A - B)/W](V_1/V_2) \quad (3)$$

where:

A = micrograms of chlorine in aliquot measured,

B = micrograms of chlorine in blank,

W = grams of mixed oxide pyrohydrolyzed,

*V*₁ = millilitres of scrub solution, and

*V*₂ = aliquot in millilitres of scrub solution analyzed.

33.2 *Determination of Chloride by Amperometric Microtitrimetry:*

¹³ The reagent is available commercially under the name Amadac-F.

33.2.1 Calibrate the titrimeter by adding 5 mL of buffer solution, 1 mL of nitric acid-acetic acid solution, and 2 drops of the gelatin solution to a titration cell. Pipet 50 μL of the chloride standard solution (1 mL = 1 mg Cl) into the titration cell. Place the cell on the chloride titrator and follow the manufacturer's suggested sequence of operations for titrating chloride. Record the time required to titrate 50 μg . Run a reagent blank titration.

NOTE 7—The chloride analyzer generates silver ions which react to precipitate the chloride ion. The instrument uses an amperometric end point to obtain an automatic shut-off of the generating current at a pre-set increment of indicator current. Since the rate of generating silver ion is constant, the amount of chloride precipitated is proportional to the time required for the titration.

33.2.2 Determine the chloride in the pyrohydrolysis scrub solution by adding 5 mL to a titration cell which contains 1 mL of the nitric acid-acetic acid solution and 2 drops of the gelatin solution.

33.2.3 Place the cell in position on the titrator. Start the titrator and record the time required to titrate the chloride present.

33.2.4 Calculate the chlorine as follows:

$$\text{Cl, } \mu\text{g/g} = V_1 F (T_s - T_B) / V_2 W \quad (4)$$

where:

- V_1 = volume of scrub solutions = 25,
- V_2 = aliquot, in millilitres, of scrub solution analyzed,
- F = micrograms of Cl standard titrated/titration time of standard – titration time of blank or
- $F = 50 / (T_{\text{Cl}} - T_B)$,
- T_s = titration time to titrate sample and blank,
- T_{Cl} = titration time to titrate 50 μg Cl and blank,
- T_B = titration time to titrate reagent blank, and
- W = grams of mixed oxide pyrohydrolyzed.

33.3 *Determination of Chloride and Fluoride With Ion-Selective Electrodes:*

33.3.1 Preparation of the calibration curves requires the assembly of the meter and the ion-selective electrode with a suitable reference electrode. From these standards take the millivolt readings for each ion-selective electrode and plot on semi-log paper the halogen content per 25 mL *versus* millivolts. Prepare a series of standards in acetate buffer solution by pipeting aliquots of the halogen standards into separate 25-mL flasks ranging in concentrations as follows:

- chloride 10 to 100 $\mu\text{g}/25$ mL
- fluoride 5 to 100 $\mu\text{g}/25$ mL

33.3.2 Determine the chloride and fluoride in the scrub solution from the pyrohydrolysis by using the appropriate ion-selective electrode. Record the micrograms of chloride or fluoride from the calibration curve and calculate the halide as follows:

$$\text{Cl or F, } \mu\text{g/g} = (H_s - H_b) / W \quad (5)$$

where:

- H_s = micrograms of halide in aliquot of scrub solution plus blank,
- H_b = micrograms of halide in pyrohydrolysis blank, and
- W = grams of sample.

33.4 *Determination of Fluoride by Spectrophotometry:*

33.4.1 Prepare a calibration curve by adding to separate 10-mL flasks 0, 50, 100, 200, 500, and 1000 μL of fluoride standard solution (1 mL = 10 μg F). Add 2.0 mL of lanthanum-alizarin complexone solution and dilute to volume with water. Mix and let stand 1 h. Read the absorbance at 622 nm *versus* the reagent blank. Plot the micrograms of fluoride per 10 mL *versus* the absorbance reading.

33.4.2 Measure the fluoride in the pyrohydrolysis scrub solution by pipeting 5 mL into a 10-mL volumetric flask. Add 2.0 mL of lanthanum-alizarin complexone and dilute to volume. Mix and let stand 1 h. Read the absorbance at 622 nm *versus* a reagent blank and obtain the fluoride content from the calibration curve.

33.4.3 Calculate the fluorine concentration in the mixed oxide sample as follows:

$$\text{F, } \mu\text{g/g} = [(F_s - F_b) / W] \times (V_1 / V_2) \quad (6)$$

where:

- F_s = fluorine in aliquot of scrub solution plus the blank, μg ,
- F_b = fluorine in pyrohydrolysis blank, μg ,
- V_1 = total volume of the scrub solution, mL,
- V_2 = aliquot of scrub solution analyzed, mL, and
- W = grams of mixed oxide sample.

34. Precision and Bias

34.1 The relative standard deviations for the measurements of fluorine are approximately 7 % for the 5 to 50- $\mu\text{g/g}$ range and 10 % for the 1 to 5- $\mu\text{g/g}$ range. The relative standard deviations for the measurements of chlorine vary from 5 % at the 5 to 50- $\mu\text{g/g}$ level and up to 10 % below the 5- $\mu\text{g/g}$ range.

SULFUR BY DISTILLATION-SPECTROPHOTOMETRY

35. Scope

35.1 This test method covers the determination of sulfur in the concentration range from 10 to 600 $\mu\text{g/g}$ for samples of nuclear-grade uranium and plutonium mixed oxides, (U, Pu) O_2 .

36. Summary of Test Method

36.1 Sulfur is measured spectrophotometrically as Lauth's Violet following its separation by distillation as hydrogen sulfide (10). Higher oxidation states of sulfur are reduced to sulfide by a hypophosphorous-hydriodic acid mixture, the hydrogen sulfide is distilled into zinc acetate, and *p*-phenylenediamine and ferric chloride are added to form Lauth's Violet. The quantity of sulfur is calculated from the measured absorbance at 595 nm and the absorbance per microgram of sulfur obtained for calibration materials having known sulfur contents. The relative standard deviation ranges from 12 to 3 % for the concentration range from 10 to 600 μg of sulfur per gram of sample.

37. Interference

37.1 None of the impurity elements interfere when present in amounts up to twice their specification limits for uranium and plutonium mixed oxides.

38. Apparatus

- 38.1 *Boiling Flask*, adapted with a gas inlet line and fitted with a water-cooled condenser and delivery tube.
- 38.2 *Spectrophotometer*, with matched 1-cm cells.
- 38.3 *Sulfur Distillation Apparatus*—see Fig. 4.

39. Reagents

- 39.1 *Argon Gas*, cylinder.
- 39.2 *Ferric Chloride Solution*, 2 % ferric chloride (FeCl_3) in 6 *M* HCl.
- 39.3 *Formic Acid*, redistilled.
- 39.4 *Hydriodic-Hypophosphorous Acid Reducing Mixture*—Mix 400 mL of 47 % hydriodic acid (HI) with 200 mL of hypophosphorous acid (H_3PO_2) (31 %) and boil under reflux for 30 min with a continuous argon sparge. Test for the sulfur content by analyzing a 15-mL aliquot as described in the procedure. Reboil if necessary to reduce the sulfur content to below 1 $\mu\text{g/mL}$.
- 39.5 *Hydrochloric Acid (0.6 M)*—Dilute 10 mL of 12 *M* hydrochloric acid (HCl) to 200 mL with water.
- 39.6 *Hydrochloric Acid (3 M)*—Dilute 50 mL of 12 *M* HCl to 200 mL with water.
- 39.7 *Hydrochloric Acid (6 M)*—Dilute 100 mL of 12 *M* HCl to 200 mL with water.
- 39.8 *Hydrochloric Acid (12 M)*—Analyze an aliquot of HCl (sp gr 1.19) for sulfur content. Use only a reagent in which the sulfur content is less than 1 $\mu\text{g}/10\text{ mL}$ and prepare the diluted acids with this reagent.
- 39.9 *Hydrofluoric Acid (HF)*, (sp gr 1.15)—Concentrated hydrofluoric acid (HF).
- 39.10 *Hydroxylamine Hydrochloride* ($\text{NH}_2\text{OH}\cdot\text{HCl}$), 20 % aqueous solution.
- 39.11 *Nitric Acid (HNO_3) (15.6 M)*, 70 %.
- 39.12 *p-Phenylenediamine (1 %)*—Dissolve 1 g of *p*-phenylenediamine in 100 mL of 0.6 *M* HCl.
- 39.13 *Silver Nitrate* (AgNO_3), 1 % aqueous solution.

39.14 *Sulfur Calibration Solution (1 mL = 5 $\mu\text{g S}$)*—Dissolve 2.717 g of dry potassium sulfate (K_2SO_4) in water and dilute to 1 L. Dilute 2.00 mL to 200 mL with water.

39.15 *Zinc Acetate Solution (4 %)*—Dissolve 20 g of zinc acetate [$\text{Zn}(\text{C}_2\text{H}_3\text{O}_2)_2$] in 500 mL of water and filter.

40. Calibration

40.1 Use aliquots of standard sulfur solution (1 mL = 5 $\mu\text{g S}$) to test the test method and check the apparatus. Ideally, blends of oxides and sulfur (20 to 600 $\mu\text{g S/g}$) should be analyzed to simulate actual sample conditions.

40.2 Prepare a calibration curve of absorbance *versus* sulfur (using aliquots of the sulfur standard solution) covering a concentration range from 5 μg to 50 $\mu\text{g}/50\text{ mL}$.

41. Procedure

41.1 Pulverize mixed oxide pellets in a mixer-mill with a tungsten carbide container and a tungsten carbide ball.

41.2 Transfer a sample, weighed to $\pm 0.2\text{ mg}$, to a 20-mL beaker or a 30-mL platinum dish. Use a 0.5-g sample when the expected level of sulfur is 100 $\mu\text{g/g}$ or less.

41.3 Add 5 mL of 15.6 *M* HNO_3 and 3 to 4 drops of 28 *M* HF and heat the solution below its boiling point. Watch glasses or platinum lids are recommended to avoid spattering.

41.4 Add additional amounts of HNO_3 and HF acids until the sample dissolves (see Note 8).

NOTE 8—The sealed-tube technique described in USAEC Document LA-4622, 1971, p. 5, is an alternative test method which may be used to advantage for the dissolution of some samples.

41.5 Evaporate the solution just to dryness, but do not fume intensely to dryness.

41.6 Dropwise add 0.5 mL of formic acid. Heat the solution at moderate heat until the vigorous reaction subsides and gases are no longer evolved.

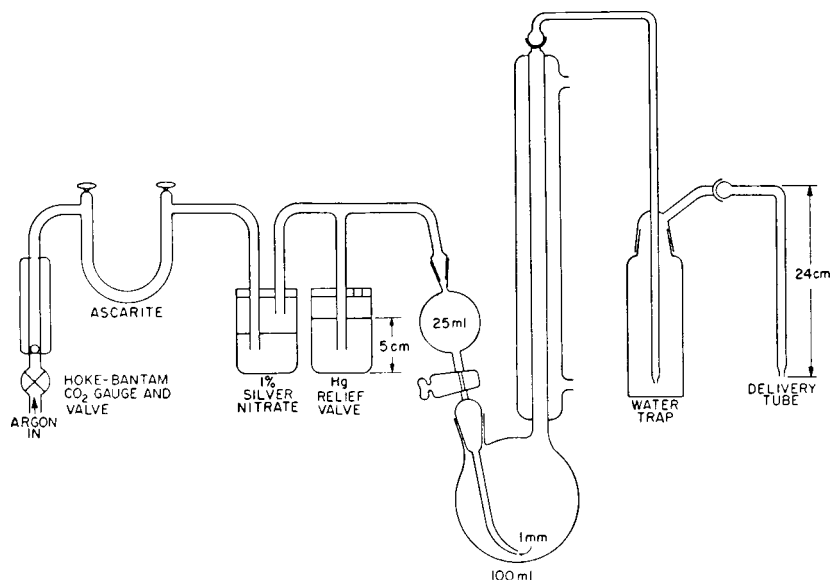

FIG. 4 Sulfur Distillation Apparatus

NOTE 9—The reduction of HNO_3 by formic acid is vigorous. Keep the dish or beaker covered with a watch glass between additions of formic acid.

41.7 Rinse the cover glass with water. Add 0.5 mL of formic acid and slowly evaporate the rinse and sample solution to dryness.

NOTE 10—Nitrate must be completely removed because it reacts explosively with the reducing acid.

41.8 Dissolve the residue in a minimum volume of 3 M HCl and dilute to approximately 5 mL with water. Heat to just below the boiling point and add 20 drops of hydroxylamine solution (Pu-III, blue, is formed).

41.9 Add 30 mL of water to the trap of the distillation apparatus (Fig. 5) and insert the trap tube.

41.10 Pipet 10.0 mL of 4 % zinc acetate solution into a 50-mL glass-stoppered graduated cylinder, dilute to 35 mL with water, and position the cylinder so the end of the delivery tube is immersed in the solution.

41.11 Transfer the sample solution (41.8) with a minimum of water rinses to the distillation flask and insert the reducing-acid delivery tube.

41.12 Add 15 mL of the reducing acid mixture and 10 mL of 12 M HCl to the delivery bulb. Insert the argon sweep gas tube and start the flow of the reducing acid mixture to the distillation flask.

41.13 Adjust the flow rate of argon to 100 cm^3/min ; then turn on the heating mantle and boil the solution for 35 min.

41.14 Disconnect the distillate delivery tube, and rinse it with 2.00 mL of 3 M HCl followed by approximately 2 mL of water, collecting these rinses in the zinc acetate solution. Rinse zinc sulfide (ZnS) formed inside the tube into the zinc acetate solution.

41.15 Pipet 1.00 mL of 1 % *p*-phenylenediamine into the solution and mix rapidly by swirling. Pipet 1.00 mL of 2 % ferric chloride solution and again mix rapidly.

NOTE 11—Rapid mixing after each reagent addition prevents formation of a brown reduction product that interferes with the spectrophotometric measurement.

41.16 Dilute to 50 mL with water, stopper the cylinder, mix the solution, and let stand 1 h.

41.17 Measure the absorbance within 10 min at a wavelength of 595 nm versus a reagent reference.

42. Calculation

42.1 Calculate the sulfur content as follows:

$$S, \mu\text{g/g} = (S - B)/W \quad (7)$$

where:

- S = micrograms of sulfur in sample,
- B = micrograms of sulfur in blank, and
- W = grams of sample.

43. Precision and Bias

43.1 The relative standard deviations in 0.1-g samples are 6 to 3 % for the range from 50 to 600 $\mu\text{g/g}$ and in 0.5-g samples are 12 to 5 % for the range from 10 to 20 $\mu\text{g/g}$.

MOISTURE BY THE COULOMETRIC, ELECTROLYTIC MOISTURE ANALYZER

44. Scope

44.1 This test method covers the determination of moisture in nuclear-grade mixed oxides of uranium and plutonium (U,Pu) O_2 . Detection limits are as low as 10 μg .

45. Summary of Test Method

45.1 The sample is heated in an oven (up to 400°C) to drive off any water. The moisture is carried from the oven into the electrolytic cell by a flowing stream of *dry* nitrogen. Two parallel platinum wires wound in a helix are attached to the inner surface of the tube, the wall of which is evenly coated with phosphorous pentoxide (a strong desiccant that becomes electrically conductive when wet). A potential applied to the wires produces a measurable electrolysis current when moisture wets the desiccant. Electrolysis of the water continuously regenerates the cell enabling it to accept additional water.

45.2 Precautions must be taken to prevent interference from the following sources: Hydrogen fluoride will cause permanent damage to the cell and sample system and should not be run under any conditions. Corrosive acidic gases such as chlorine and hydrogen chloride will corrode the instrument. Entrained liquids and solids can cause cell failure and should be prevented from entering the gas stream. Ammonia and other basic materials react with the acidic cell coating and render the cell unresponsive. Hydrogen, and to a lesser extent, oxygen or air, may cause a high reading due to recombination in the cell, or in the case of hydrogen due to reaction with oxide coating of the sample boat to produce water. Alcohols and glycols, particularly the more volatile ones, respond like water and therefore must not be present.

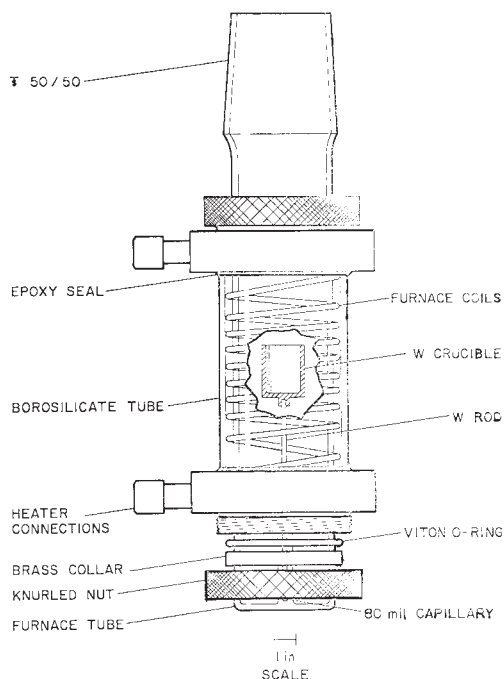

FIG. 5 Induction Furnace



46. Apparatus

46.1 *Moisture Analyzer*,¹⁴ for solids, with a quartz-glass oven, capable of being heated from ambient temperatures to 1000°C. The assembly is to include an electrolytic cell, flow meter, range from 30 to 140 cm³/min of air, and a dryer assembly.

46.2 *Balance*,¹⁵ for weighing samples in the range from 1 to 100 mg.

46.3 *Nitrogen Gas Cylinder*, with a pressure regulator, a flowmeter, and a drying tower.

47. Reagents

47.1 *Barium Chloride Dihydrate* (BaCl₂·2 H₂O).

48. Operation

48.1 Turn the main power switch ON.

48.2 Adjust nitrogen gas pressure to 41.4 kPa (6 psi) and the flow rate to 50 mL/min measured at the exit of the apparatus.

48.3 Weigh the sample into a small, dry aluminum boat (Note 12) and insert it into the instrument oven as follows.

NOTE 12—For samples that have been reduced in a hydrogen atmosphere and thus contain excess hydrogen, the use of a platinum boat in place of the aluminum tube and nickel boat will minimize any interference due to the hydrogen.

48.4 Open the top of the analyzer and remove the TFE-fluorocarbon plug. Do not touch with gloves.

48.5 With forceps pull the nickel boat one third of the way out of the tube and place the aluminum boat and sample inside the nickel boat. Then reposition the nickel boat near the center of the heating coils.

48.6 Replace the TFE-fluorocarbon plug and close the lid of the analyzer.

48.7 Reset the counter to 0 µg.

48.8 Set the timer at 1 h.

48.9 Set the temperature at 400° C. This will activate the analyzer and start the heating cycle.

48.10 When the preset temperature has been reached and the counter ceases counting, record the reading, *S*.

49. Standardization

49.1 Determine the blank by processing dry, empty aluminum boats in accordance with 48.4 through 48.10 until constant values are obtained.

49.2 Weigh and analyze replicate 5-mg samples of BaCl₂·2 H₂O until consistent results are obtained. Sodium tungstate dihydrate (NaWO₄·2 H₂O) may also be used for calibration.

50. Calculation

50.1 Calculate the moisture recovery, *Z*, for the standard as follows:

$$Z = (A - B)/147.2Y \quad (8)$$

where:

A = micrograms of moisture on counter when standard is tested,

B = micrograms of moisture on counter from blank, and

Y = milligrams of BaCl₂·2 H₂O. Each milligram of BaCl₂·2 H₂O contains 112.2 µg of water.

50.2 Calculate the moisture in the sample as follows:

$$\text{Moisture, } \mu\text{g/g} = (S - B)/WZ \quad (9)$$

where:

S = micrograms of moisture on counter when sample is tested,

B = micrograms of moisture on counter from blank,

W = grams of sample, and

Z = recovery of moisture from standard.

51. Precision and Bias

51.1 The relative standard deviation for moisture in a concentration range of 100 µg/g is approximately 2 % but increases to 10 % at the 20 µg/g level.

ISOTOPIC COMPOSITION BY MASS SPECTROMETRY

(This test method was discontinued in 1980 and replaced by Sections 106 to 114.)

RARE EARTHS BY COPPER SPARK SPECTROSCOPY

52. Scope

52.1 This test method covers the determination of rare earths in uranium-plutonium dioxide over the range from 10 to 200 µg/g.

53. Summary of Test Method

53.1 The general principles of emission spectrographic analysis are given in an ASTM publication (11). Determination of rare earth content requires their separation from uranium and plutonium by solvent extraction followed by copper-spark spectrographic measurement (12, 13).

54. Apparatus

54.1 *Spectrograph*— Commercially available equipment with reciprocal dispersion of approximately 2.5 Å/mm (second order). A direct-reading spectrograph of comparable quality may be substituted for the equipment listed, in which case the directions given by the manufacturer should be followed rather than those given in the succeeding steps of this procedure. The excitation stand must be mounted in a glove box. Power controls must be able to supply the conditions called for in 57.4.

54.2 *Microdensitometer* with a precision of ±1.0 % for transmittances between 5 and 90 %.

54.3 *Electrodes*—Electrolytic copper, 6.4 mm (¼in.) in diameter by 38.1 mm (1.5 in.) long.

54.4 *Magnetic Stirrer*.

¹⁴ A CEC Solids Moisture Analyzer of Type 26-321A-MA, available from DuPont Instruments, Inc., S. Shamrock Ave., Monrovia, CA 91016, or equivalent, has been found satisfactory.

¹⁵ A Cahn Electrobalance, or equivalent, available from Cahn Div., Ventrone Instruments Corp., Paramount, CA, has been found satisfactory.

54.5 *Photographic Plates.*¹⁶

55. Reagents and Materials

55.1 *Boric Acid Crystals* (H_3BO_3).

55.2 *Dissolution Mixture*—Add 10 drops of hydrofluoric acid (HF, 1 + 20) to 10 mL of nitric acid (HNO_3 , sp gr 1.42).

55.3 *Hydrochloric Acid (6.7 M)*—Dilute 56 mL of hydrochloric acid (HCl, sp gr 1.19) to 100 mL with water.

55.4 *Hydrochloric Acid (1 M)*—Dilute 16.7 mL of HCl (sp gr 1.19) to 200 mL with water.

55.5 *Internal Standard Solution, Yttrium (Y) (1 mL = 2.5 μg Y)*—Dissolve 100 mg of yttrium metal in HCl (1 + 1) and dilute to 100 mL with HCl (1 + 1). Dilute 250 μL of this solution to 100 mL with HCl (1 + 1).

55.6 *Nitric Acid (4 M)*—Dilute 2.6 mL of nitric acid (HNO_3 , sp gr 1.42) to 10 mL with water.

55.7 *Rare Earth Standard Solutions*—Prepare separate solutions of samarium, europium, gadolinium, and dysprosium in HCl (1 + 1). Weigh and dissolve sufficient metal or oxide to obtain 10 μg of the element per mL of solution.

55.8 *Tri-n-Octylamine* (TOA), 20 volume percent in xylene.

56. Calibration

56.1 *Emulsion Calibration*—Calibrate the emulsion in accordance with Practice E 116.

56.2 *Preparation of Analytical Curve*—Read and record transmittance measurements of the spectra for each of five standard samples that cover the test range. Convert the transmittance measurements of the analytical line and the internal standard line to log-intensity ratios, using the emulsion calibration curve.

57. Procedure

57.1 *Dissolution of Sample:*

57.1.1 Weigh a pellet (approximately 1.5 g) or powder (approximately 1 g) to ± 0.001 g and place in a 50-mL volumetric flask.

57.1.2 Add 5 mL of the dissolution mixture, and heat slowly until dissolution is complete. Allow the solution to cool, then dilute to volume with 6.7 M HCl and mix thoroughly.

57.2 *Separation from Actinides:*

57.2.1 Transfer a 10-mL aliquot of the solution from 57.1.2 to a 35-mL vial containing 10 mL of TOA, 4 mL of yttrium standard, 5 mg of H_3BO_3 crystals and a magnetic stirring bar.

57.2.2 Stir vigorously for 3 min. Let the solution stand for 15 min to permit phase separation.

57.2.3 Discard the organic phase (upper layer).

57.2.4 Add 10 mL of TOA and repeat 57.2.2 and 57.2.3.

57.2.5 Add 2 mL of xylene and stir for 1 min. Allow the phases to separate and discard the organic phase.

57.2.6 Evaporate the aqueous phase to dryness under a heat lamp.

57.2.7 Add 1 mL of 1 M HCl. Warm and swirl to dissolve the residue.

57.3 *Preparation of Electrode*—Transfer 50 μL of the solution from 57.2.7 to a pair of cleaned copper electrodes and evaporate to dryness under a heat lamp. Evaporate slowly to avoid spattering of the sample. Adjust the analytical gap to 2.0 mm.

57.4 *Excitation and Exposure*—Produce and record the spectra according to the following conditions:

<i>Electrical Parameters:</i>	
Discharge	high-voltage spark
Voltage (primary), V	90
Capacitance, μH	0.0025
Current, rf, A	10
<i>Exposure Conditions:</i>	
Analytical gap, mm	2.0
Prespark	0
Exposure, s	30
Slit width, μm	10
Slit height, mm	2
Filter, percent transmittance	100/50

57.5 *Photo Processing*—Process the emulsion in accordance with Practices E 115.

57.6 *Photometry*—Measure the percentage of transmittance of the analytical lines with the microphotometer.

58. Calculation

58.1 Convert the transmittances of the analytical and the internal standard lines of the sample into log-intensity ratios. Determine percentage concentration from the analytical curves. Report the average of triplicate determinations for each sample.

59. Precision and Bias

59.1 The *precision* of the test method is based on a duplicate measurement of the rare earths over a period of several days. An average relative standard deviation of 10 % was obtained.

59.2 The *bias* of the test method is dependent on the reliability of the solution standards. It is estimated that the bias of the test method is comparable to its precision.

TRACE IMPURITIES BY CARRIER DISTILLATION SPECTROSCOPY

60. Scope

60.1 This test method covers the analysis of uranium-plutonium dioxide [(U, Pu) O_2] for the 25 elements in the ranges indicated in Table 1, using gallium oxides or sodium fluoride as the carrier. (See also Table 2.)

61. Summary of Test Method

61.1 The sample of uranium-plutonium dioxide is homogenized by grinding it in an agate mortar or a mixer mill. A weighed portion is taken, mixed with gallium oxide or sodium fluoride carrier, and arced on the spectrograph. An internal standard of Co_2O_3 is added if densitometric measurements are taken.

62. Apparatus

62.1 *Sample Preparation Equipment:*

62.1.1 *Pulverizer-Mixer*¹²—Mechanical mixer with a plastic vial and ball. Grinding may be done with a highly polished agate mortar and pestle if a mechanical grinder is not available.

¹⁶ Eastman Kodak SA-1, or equivalent, has been found satisfactory for this purpose.

TABLE 1 Impurities in Uranium-Plutonium Oxide

Element	Carrier	Concentration, ppm	Wavelength, Å
Ag	a ^A	0.5 to 25	3280.68
Al	a or b ^B	10 to 500	2567.99 ^C , 3082.16 ^C , 3092.71
B	a	0.5 to 25	2496.78, 2497.73
Ba	b	1 to 50	4554.04 ^D
Be	b	0.5 to 25	2348.61
Bi	a	0.5 to 25	3067.72
Ca	b	5 to 250	4226.73
Cd	a	4 to 40	2288.02, 3261.06
Co	a	2 to 100	2407.25, 2519.82, 3044.00
Cr	a or b	5 to 500	4254.35, 4274.80, 4289.72, 2835.63 ^A
Cu	a or b	1 to 250	3247.54, 3273.96
Fe	a or b	10 to 500	2483.27, 3020.64 ^C
Mg	a	5 to 250	2795.53, 2802.69, 2852.13
Mn	a or b	2 to 100	2798.27, 2801.06
Mo	a	5 to 250	3170.35, 3193.97, 3132.59
Na	a	2 to 100	5889.95, 5895.92 ^D
Ni	a or b	10 to 500	3052.82 ^A , 3002.49 ^A , 3003.63 ^A , 3414.76
P	a	50 to 250	2553.28, 2554.93 ^E
Pb	a	2 to 100	2833.07, 2614.18
Si	a or b	10 to 500	2516.12 ^A , 2881.58, 2514.32 ^C
Sn	a	2 to 100	2839.99, 3175.02, 3262.33, 2863.33
Ti	b	10 to 500	3349.03, 3234.52
V	b	2 to 100	3183.41, 3183.98, 3187.71
Zn	b	2 to 100	3345.02, 3302.59, 3282.33
Zr	b	100 to 500	3391.97, 3348.23

^Aa = Ga₂O₃.

^Bb = NaF - Co₂O₃.

^CThese lines may be used for microphotometric comparison with an internal standard.

^DUse Eastman Kodak 1-N film.

^EBoth times must be observed to confirm the presence of phosphorus.

TABLE 2 Suggested Analytical Lines

Element	Wavelength, Å
Sm	3568.27
Eu	3819.67
Gd	3362.23
Dy	3531.70
Y	3710.30 (internal standard)

62.2 *Balance*, torsion type, with a capacity up to 10 g, capable of weighing to the nearest ±0.1 mg accurately.

62.3 *Excitation Source*, capable of providing 15 A d-c (short circuit).

62.4 *Excitation Stand*—Conventional type with adjustable water-cooled electrode holders, in a glove box.

62.5 *Spectrograph*, which provides a reciprocal linear dispersion of 5.12 Å/mm (first order 4000 to 7800 Å) and 2.5 Å/mm (second order 2100 to 4100 Å). A direct reading spectrograph of comparable quality may be substituted for the equipment listed, in which case the directions given by the manufacturer should be followed rather than those given in the succeeding steps of this procedure.

62.6 *Comparator*.

62.7 *Microphotometer*, having a precision of 1.0 for transmittances between 5 and 90 %.

62.8 *Photographic Processing Equipment*, to provide facilities for developing, fixing, washing, and drying operations and conforming to the requirements of Practices E 115.

62.9 *Calculating Equipment*, capable of transposing percent transmission values into intensity or density values.

63. Reagents and Materials

63.1 *Cobalt Oxide* (Co₂O₃), > 99.99 % purity, <10 μm particle size.

63.2 *Gallium Oxide* (Ga₂O₃), > 99.99 % purity, <10 μm particle size.

63.3 *Sodium Fluoride* (NaF), >99.99 % purity, <10 μm particle size.

63.4 *Sodium Fluoride-Cobalt Oxide Mixture*—Weigh 5.000 g of NaF and 0.10 g of Co₂O₃. Transfer the two compounds to a plastic vial that contains a plastic ball, and homogenize on a mechanical mixer.

63.5 *Electrodes*—The counter electrodes are made from graphite rods, ASTM Type C-6. The sample electrode is a cupped electrode, ASTM Type S-2.

63.6 *Photographic Plates*.¹⁷

63.7 *Venting Tool* (see Fig. 6).

64. Safety Precautions

64.1 Plutonium materials are highly toxic and extreme care must be used to ensure safe containment.

65. Calibration

65.1 *Densitometric Method*:

65.1.1 *Emulsion Calibration*—Calibrate the emulsion in accordance with Practice E 116.

65.1.2 *Preparation of Analytical Curves*—Make quadruplicate exposures of at least four standards. Convert the percent transmittances of the analytical lines and the internal standard lines to log intensity ratios using the emulsion calibration curve. Prepare analytical curves by plotting the log intensity ratio *versus* the log concentration for each element.

66. Procedure

66.1 *Preparation of Standards*:

66.1.1 A minimum of four standards containing from 0.5 to 500 ppm of each of the impurity elements to be determined are prepared by adding known amounts of each impurity to a mixed oxide matrix. Care should be taken to ensure that the standard is homogeneous and that the uranium to plutonium ratio is the same as the ratio in the samples to be analyzed. The density and particle size of the standards should closely approximate that of the sample.

66.2 *Preparation of Sample*:

66.2.1 Grind from 1 to 1.5 g of sample to a fine powder (approximately -200 mesh).

66.2.2 Weigh 350 mg of the powdered sample into a polystyrene vial, and add 21 mg of Ga₂O₃. Place a plastic ball in the vial and mix for 2 min.

66.2.3 If microphotometric measurements against an internal standard are to be performed, weigh an additional 250 mg of the powdered sample into a separate vial containing 13 mg of NaF·Co₂O₃(50 + 1) and mix for 2 min.

66.3 *Analysis of Sample*:

66.3.1 Transfer a 100-mg portion of each of the mixtures into the cupped electrodes, ASTM Type S-2, and tap gently to settle the charge. Vent with the venting tool (Fig. 6).

¹⁷ Eastman SA-1 or 1 N, or equivalent, have been found satisfactory for this purpose.

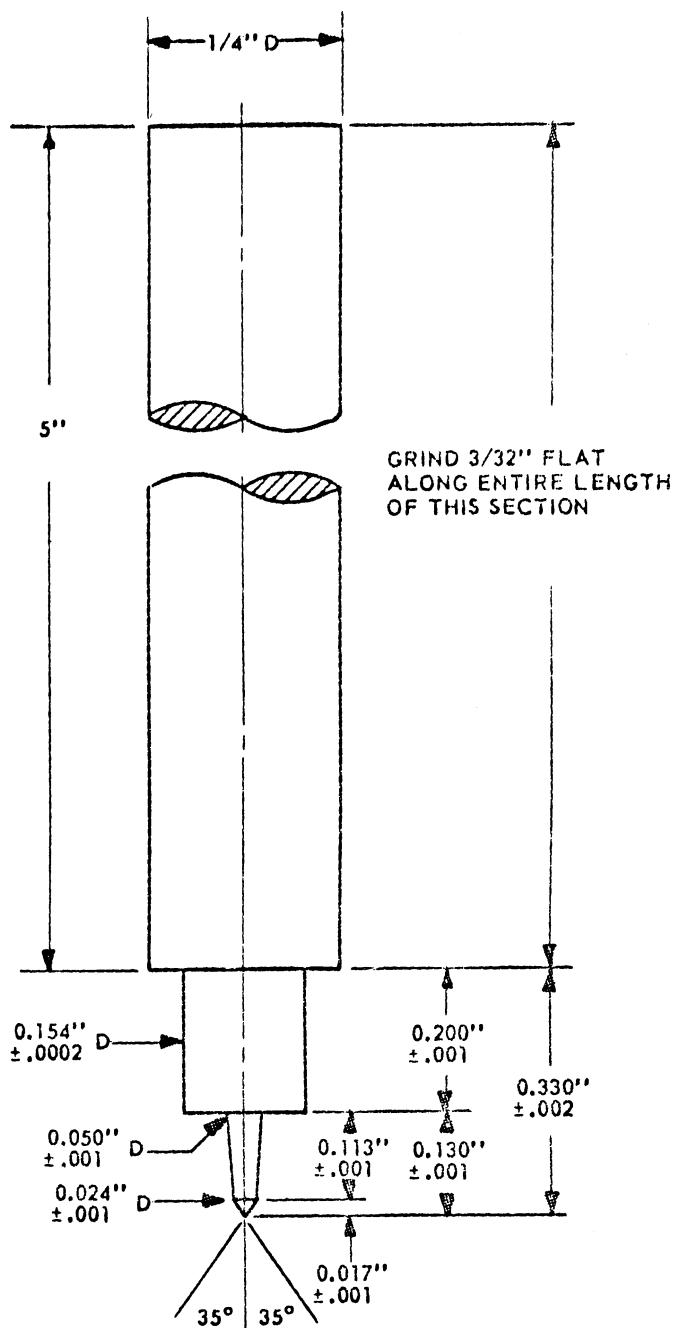

FIG. 6 Venting Tool

66.3.2 Make duplicate exposures of each sample in each region of the spectrum and duplicate exposures of 4 or more standards representing high and low concentrations of impurities.

66.4 Excitation Conditions:

<i>Electrical Parameters:</i>	
Voltage, V	250
Current, d-c, A	15
<i>Exposure Conditions:</i>	
Spectral region, Å	
Eastman SA-1 plates	2100 to 4300
Eastman 1N plates	3200 to 7750
Slit width, μm	10
Slit length, mm	2.5
<i>Exposure Conditions:</i>	

Preburn, s	
Ga ₂ O ₃	0
NaF·Co ₂ O ₃	0
Exposure, s	
Ga ₂ O ₃	40
NaF·Co ₂ O ₃	50

66.5 Photographic Processing:

66.5.1 Process the plates in accordance with Practices E 115.

67. Measurement

67.1 Visual Comparative Analysis:

67.1.1 Visually compare the density of the sample impurity spectral line with the corresponding line in a standard spectrum. Estimate the impurity concentration using the lines listed in Table 3.

67.2 Photometry—Measure the transmittance of the analytical lines with a microphotometer and the internal standard lines selected for use with each element. For iron, chromium, nickel, magnesium, and manganese use cobalt (3044.00) and for aluminum and silicon, use cobalt (2407.25).

68. Calculation

68.1 From the observed log intensity ratio, read the impurity concentration from the appropriate analytical curve.

69. Precision and Bias

69.1 Precision—For photometric measurements, relative standard deviations from 8 to 25 % have been observed (14, 15). For visual estimates, factor-of-two (that is - 1/2 to + 2) reproducibility is reported (15).

IMPURITIES BY SPARK-SOURCE MASS SPECTROGRAPHY

70. Scope

70.1 This test method covers the spark source spectrographic analysis of uranium and plutonium dioxide for impurity elements. Because of its extreme sensitivity, it may be the most practical test method for the determination of certain impurities whose concentration is below the detectable limits of other spectrographic methods.

TABLE 3 Impurity Elements and Detection Limits

Impurity	Lower limit of detection, ppm
Al	1 ± 1
B	0.1 ± 0.1
Cd	1 ± 1
Co	0.3 ± 0.3
Ca	0.5 ± 0.5
Cr	0.5 ± 0.5
Fe	0.5 ± 0.5
Mg	0.3 ± 0.3
Mn	0.3 ± 0.3
Mo	1.5 ± 0.5
K	0.3 ± 0.3
Ni	0.5 ± 0.5
Si	1 ± 1
Ti	0.3 ± 0.3
Hg	1 ± 1
Th	1 ± 1

71. Summary of Test Method

71.1 Spark-source mass spectrography (16–22) is the most convenient method for determining impurity elements in mixed oxides which occur in low concentration. Detection limits for most elements are in the atom-parts-per-billion range in mixed oxides. The procedure consists of forming the sample into rods with a cross-sectional area of 0.0323 to 0.06452 cm² (0.005 to 0.01 in.²) and a length of 12.7 mm (0.5 in.). A radio-frequency spark is generated between two such rods mounted in a high vacuum chamber. The ions formed in the spark are focused according to their energy and according to their mass-to-charge ratio, on a photographic plate. The densities of the resulting lines are compared with standards or with minor isotope lines of the matrix materials. Bias and precision vary with the test method of data interpretation and the concentration of the impurities.

71.2 Some impurities, such as iron, occur as inclusions. If metallographic examination indicates the presence of inclusions, a representative portion must be homogenized by grinding before preparation of the electrodes.

72. Apparatus

- 72.1 *Analog Computer*,¹⁸ H&D.
- 72.2 *Balance*, analytical.
- 72.3 *Beakers*, TFE-fluorocarbon.
- 72.4 *Darkroom*, equipped with photographic developing tanks and plate drying ovens.
- 72.5 *Forceps*, tantalum.
- 72.6 *Isostatic Pressure Vessel*.
- 72.7 *Laboratory*, with clean room environment.
- 72.8 *Microphotometer*,¹⁹ recording.
- 72.9 *Oven*, vacuum.
- 72.10 *Photographic Plates*.²⁰
- 72.11 *Plate Viewer*.²¹
- 72.12 *Shaker*.²¹
- 72.13 *Spark Source*, mass spectrograph.²²
- 72.14 *Vials*, plastic 51 by 19.1 mm (2 in. by 3/4 in.), with caps.

73. Reagents

- 73.1 *Acetone*.
- 73.2 *Darkroom Supplies*, developer,²³ short stop, dilute acetic acid, and fixer.²⁴
- 73.3 *Naphthalene*, flakes (resublimed, Baker and Adamson).
- 73.4 *Silver Powder* (purity, 99.999 % Ag).

74. Procedure

- 74.1 Prepare and load samples in a clean room environment.
- 74.2 *Sample Preparation:*

74.2.1 Weigh, to the nearest 0.1 mg, about 1 g of a mixed oxide sample and 1 g of powdered silver metal (99.999 % Ag) and transfer them to a 51 by 19.1-mm (2 by 3/4-in.) plastic vial.

74.2.2 Mix the contents on a shaker for 5 min.

74.2.3 Load the sample-silver mixture into a cylindrical naphthalene mold and press the mixture isostatically into a sample rod by applying a pressure of about 1034 MPa (150 000 psi) for 1 min.

74.2.4 Remove the naphthalene mold from the sample rod either by sublimation or by solution in acetone.

74.2.5 Place the sample rod in a vacuum oven and allow it to dry for at least 30 min.

74.2.6 The sample is now ready to be loaded into the instrument for evacuation.

74.3 Sparking the Samples:

74.3.1 Detailed instructions for operating the spectrograph should be followed.

74.3.2 Load two sample rods, each approximately 12.7 mm (0.5 in.) long, counter to each other in the ion source of the mass spectrograph. (If only one sample rod is available, load it counter to a high-purity silver or gold probe electrode.) Evacuate the ion source to a pressure of approximately 13.3 μPa (1 × 10⁻⁷ mm Hg). If it is necessary to measure carbon, oxygen, and nitrogen in the sample, bake the source at 150°C for 12 h. The ultimate pressure reached is about 266 nPa (2 × 10⁻⁹ mm Hg).

74.3.3 When the pressure is low enough, spark the samples so that an ion beam is generated. The instrument parameters are:

Accelerating voltage, kV	20
RF voltage, kV	approximately 30 (60 for insulators)
Magnet current, mA	305 (105 for lithium and boron)
Source pressure, μPa (mm Hg)	13.3 (1 × 10 ⁻⁷)
Analyzer pressure, μPa (mm Hg)	1.33 (1 × 10 ⁻⁸)
Spark repetition rate, pulses/s	10 to 300
Spark duration, μs	25 to 100

74.3.4 The ion beam produced is measured electronically by intercepting 50 % of the beam before separating according to the mass-to-charge ratio. By use of the electronic monitor, a series of graded exposures are made on the photographic plate.

74.3.5 Exposures needed for a specific detection limit are:

Detection Limit	Exposure in Coulombs
1 to 3 ppb atom	1 × 10 ⁻⁶
10 ppb atom	1 × 10 ⁻⁷
100 ppb atom	1 × 10 ⁻⁸
1 ppm atom	1 × 10 ⁻⁹
10 ppm atom	1 × 10 ⁻¹⁰

The average detection limit has been about 2 ppb atom for a 1 × 10⁻⁶C exposure.

74.4 Developing the Plates:

74.4.1 Remove the photographic plate from the instrument and transfer it to the darkroom.

74.4.2 Process the photographic plate as follows: develop for 3 min, short stop in dilute acetic acid, fix for 45 s in a rapid fixer, and rinse thoroughly with distilled water.

74.4.3 Place the developed plate in an oven and dry it for at least 10 min.

¹⁸ Jarrell-Ash Model 23-515, or equivalent, has been found satisfactory.

¹⁹ Jarrell-Ash Model 24-310, or equivalent, has been found satisfactory.

²⁰ Ilford QII have been found satisfactory.

²¹ Surveyor Microfilm Readers, or equivalent, has been found satisfactory.

²² A spectrometer Type MS-7 or MS-702, made by Associated Electrical Industries Ltd., has been found satisfactory.

²³ Eastman Kodak D-19 developer has been found satisfactory.

²⁴ Eastman Kodak rapid fixer has been found satisfactory.



75. Calculation

75.1 Visual Estimation of Line Density:²⁵

75.1.1 Visual estimation of line density is used for all low-level impurities (<1.0 ppm atomic) and for many high-level impurities. This type of interpretation usually gives data that are accurate within a factor of two. This calculation is:

$$PS = (E_{\min}/E_{\max}) \times (A_s/100) \times (I_s/100) \times 10^6 \quad (10)$$

where:

- PS = the plate sensitivity,
- E_{\min} = shortest exposure on the photographic plate, nC,
- E_{\max} = longest exposure on the photographic plate, nC,
- A_s = concentration of the chosen internal standard in atom percent, and
- I_s = isotopic abundance of the chosen isotope of the internal standard element, atom %.

75.1.2 Then:

$$C_i = PS \times (E_{\max}/E_{\det}) \times (100/I_i) \quad (11)$$

where:

- C_i = concentration of the impurity, in ppm atomic,
- PS = plate sensitivity,
- E_{\max} = longest exposure on the photographic plate, nC,
- E_{\det} = shortest exposure in nanocoulombs on which the impurity isotope can be detected, and
- I_i = isotopic abundance of the chosen impurity isotope, atom %.

75.1.3 Now:

$$W_i = C_i \times (I_d/M_a) \quad (12)$$

where:

- W_i = the concentration of the impurity, in ppm mass,
- C_i = concentration of the impurity, in ppm atomic,
- I_d = atomic mass of the impurity, and
- M_a = average atomic mass of the matrix.

(When mixed, pressed samples are used, it is necessary to correct for the impurities present in the silver support material.)

75.2 Measurement of Line Density:²⁶

75.2.1 When more accurate and precise values are required, it is necessary to measure the line densities on the photographic plate with a microphotometer. The line transmission is measured and the transmission percent is converted to the line density with the analog computer and a previously determined emulsion calibration curve. From the measured line densities, composition may be derived in two ways.

75.2.1.1 First, when a standard having the same ratio of mixed oxide to silver metal and containing the same impurity elements as the sample is available, then under the same conditions of exposure:

$$C_i = (I_u/I_s) \times C_s \quad (13)$$

where:

- C_i = concentration of the impurity in the sample,
- I_u = density of the impurity line in the sample,

- I_s = density of the impurity line in the standard, and
- C_s = concentration of the impurity in the standard.

75.2.1.2 Second, if the calculations are based on standard impurity elements other than those desired, the calculation becomes:

$$C_i = (D_i/D_s) \times (A_s/100) \times (I_s/I_i) \times (E_s/E_i) \times (S_s/S_i) \times (M_i/M_s) \quad (14)$$

where:

- C_i = concentration of the impurity in the sample, atom %,
- D_i = density or intensity of the impurity line,
- D_s = density or intensity of the standard line,
- A_s = concentration of the standard, atom %,
- I_s = isotopic abundance of the standard isotope, atom %,
- I_i = isotopic abundance of the impurity isotope, atom %,
- E_s = exposure at which the standard line is measured, nC,
- E_i = exposure at which the impurity line is measured, nC,
- S_s = relative sensitivity factor for the standard element,
- S_i = relative sensitivity factor for the impurity element, and
- M_i and M_s = single-to-multiple-charge ratio for the two elements in question (preferably 1).

76. Precision and Bias

76.1 *Precision and Bias*—The microphotometric test method for spectral density interpretation should be employed for (U, Pu)O₂ samples. The precision for the technique of impurity evaluation is equal to or less than ±30 % at the 95 % confidence level. This precision is applicable to all specification limits set forth for each impurity in the mixed oxide. Since standards are to be used, the bias is comparable to the precision.

76.2 Examples of some of the lower practical limits of detection are listed in Table 3.

TOTAL GAS IN REACTOR-GRADE MIXED DIOXIDE PELLETS

77. Scope

77.1 This test method covers the measurement of volatiles other than water in reactor-grade mixed dioxide pellets. The lower limit of the test method using the described equipment and a sample of approximately 1 g is 0.01 cm³ per gram of sample at STP conditions (23).

78. Summary of Test Method

78.1 A weighed sample is transferred into the outgassing section of the apparatus in a position for subsequent dropping into a tungsten crucible. The system is evacuated and the tungsten crucible without the sample is outgassed at 1600° C until the gas released from the empty crucible during a 35-min collection period decreases to less than 0.01 cm³ at STP conditions. After the crucible cools, the sample is dropped into it and heated at 1600° C for 35 min. The released gas passes

²⁵ The SSMS2 Program for CEIR Computer Service has been found satisfactory for this computation.

²⁶ Cole-Parmer Micro V Model 4805, obtained from Cole-Parmer Instrument and Equipment Co., Chicago, IL, or equivalent, has been found satisfactory.

through a magnesium perchlorate trap to remove water vapor and thence into a calibrated volume where the temperature and pressure are measured. The gas content of the sample is calculated at STP conditions assuming that the released gas is ideal.

78.2 Since this is an empirical method, it is important that the steps in the procedure be followed carefully in order to insure results that have a reliability approximating that given in Section 84.

79. Interferences

79.1 No interferences are expected with the exception of water in the sample which partially reacts with the tungsten crucible to produce hydrogen. The magnitude of this interference, although unknown, probably is insignificant because of rapid removal of water vapor from the vicinity of the crucible.

80. Apparatus

80.1 *Vacuum Outgassing and Gas Measuring Apparatus*—(see Figs. 5-8).

80.1.1 *Outgassing Section* (Fig. 5 and Fig. 7), consisting of a water-cooled, fused-silica furnace tube heated with induction coils, and a pellet loading arm with an externally operated magnet feed. A glass wool plug is placed in the line just after the furnace tube adapter to prevent transfer of small particles of mixed oxide to the gas-measuring section.

80.1.2 *Gas-Measuring Section* (Fig. 8), consisting of a mercury diffusion pump capable of transferring the gas against a forepressure equivalent to 667 Pa (5 torr), a magnesium perchlorate trap to remove water, another mercury diffusion pump, a Toepler pump fitted with a removable calibrated-volume sample tube, and a McLeod gage, a mercury diffusion pump, and a mechanical forepump. The Toepler pump cycle is controlled by electrically timed solenoid valves in the vacuum and pressure lines. This method of control eliminates the

possibility of reactions caused by electrical sparks in a system controlled by mercury contacts. The mechanical pump should be used to maintain vacuum in the system during periods when the equipment is not in use.

80.1.3 *Tungsten Crucible.*

81. Reagents

81.1 *Grease*, high-vacuum (silicone).

81.2 *Magnesium Perchlorate*—(Mg(ClO₄)₂) anhydrous.

82. Procedure

82.1 Determine a crucible blank for the entire system before each sample is analyzed. The procedure for the crucible blank is included in 82.2.

82.2 The apparatus can be calibrated by either of the two following test methods:

82.2.1 Measure the volume of the removable sample tube on the Toepler pump or,

82.2.2 A more accurate test method is to introduce known volumes of gas into the system through *V* in Fig. 8 and measure these in the gas-measuring section in the same manner as the samples are measured. The calibration gas for this test method can be hydrogen, usually a major component of the gas released from samples. A series of known volumes covering the range from 0.01 to approximately 0.2 STP cm³ is recommended for this test method. This technique corrects for slight losses in the vacuum pumps.

82.3 *Analysis of Samples:*

NOTE 13—Only results that fall within the linear range of the calibration curve should be accepted. If results on samples are beyond this range the test should be repeated with a smaller sample.

82.3.1 Start the three diffusion pumps. Refer to Fig. 8 for all steps.

82.3.2 Close valves *V*₂ and *V*₃.

82.3.3 Open valve *V*₁ and flush the furnace tube with argon while placing the sample in the sample holder.

82.3.4 Transfer a weighed sample into the arm of the sample loader.

82.3.5 Replace the sample loader on the furnace tube adapter, using silicone grease to make a seal.

82.3.6 Close valves *V*₁, *V*₄, *V*₅, *V*₇, *V*₈, *V*₁₀, *V*₁₂, and *V*₁₆.

82.3.7 Slowly open valve *V*₃ to evacuate the system with the mechanical pump *Q*.

NOTE 14—Rapid opening of valve *V*₃ will cause violent agitation of the mercury in the Toepler pump and possible breakage of the pump.

82.3.8 When the pressure indicated on thermocouple gage *P* decreases to 67 Pa (0.5 torr), open valves *V*₂, *V*₄, *V*₅, *V*₇, *V*₈, *V*₁₀, *V*₁₂, and *V*₁₆, and close valves *V*₃, *V*₆, *V*₉, *V*₁₃, and *V*₁₅.

82.3.9 When the pressure decreases to less than 1.33 Pa (0.01 torr), start the induction generator and slowly heat the crucible up to 1600° C over a period of approximately 4 h.

NOTE 15—A slow outgassing rate is required to prevent excessive coating of the furnace tube walls with tungsten oxides formed by the reaction between tungsten and water vapor. An excessive deposit causes overheating of the O-ring seals and leakage of cooling water.

82.3.10 Heat the crucible at 1600° C for 0.5 h; then close valve *V*₁₁, and adjust the pressure in the mercury reservoir *M*,

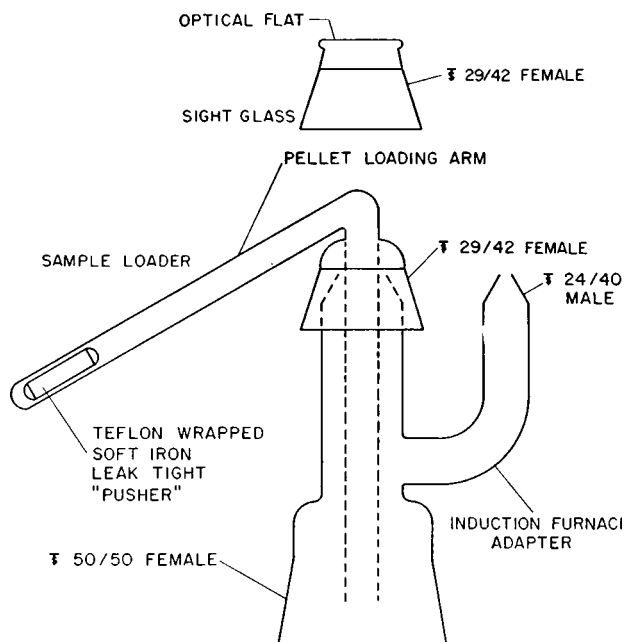
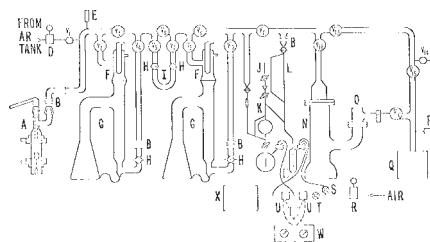

FIG. 7 Furnace Tube Adapter and Sample Loader



- | | |
|------------------------------|---------------------------|
| A—Induction furnace | M—Mercury reservoir |
| B—Monel bellows | N—Mercury diffusion pump |
| C—Glove box wall | O—Water-cooled condenser |
| D—Low-pressure regulator | P—Thermocouple gage |
| E—Thermocouple gage | Q—Mechanical forepump |
| F—Water-cooled condenser | R—Low-pressure regulator |
| G—Mercury diffusion pumps | S—Needle valve |
| H—Semi-ball joint | T—Needle valve |
| I—Magnesium perchlorate trap | U—Solenoid valves |
| J—Calibrated sample volume | V—Electric counter |
| K—Toepler pump | W—Electric timer |
| L—McLeod Gage | X—Mechanical vacuum pumps |

FIG. 8 Outgassing and Gas Measuring Apparatus

using needle valve *S*, until mercury half-fills the side arm leading to the Toepler pump.

82.3.11 Turn on the Toepler pump timer *W*, and collect the gas evolved from the crucible in the sample tube *J*, for 70 cycles of the Toepler pump as registered on the counter *V*.

NOTE 16—The time required for collection is dependent on the construction of the Toepler pump. The use of large-bore stopcocks and tubing will permit a cycle rate of 1 cycle/25 to 30 s.

82.3.12 At the completion of the collection period close the stopcock between the Toepler pump mercury reservoir and the expansion volume with the mercury at the top of its cycle.

82.3.13 Open valve *V*₁, and raise the mercury in the side arm, by opening needle valve *S*₁ until the level reaches a predetermined calibration mark on the sample tube.

82.3.14 Measure the difference in heights of the columns of mercury in the sample tube and the adjacent McLeod gage *L*. This difference is the total pressure of the collected gas.

82.3.15 Record the temperature of the sample tube and the pressure of the gas, and calculate the volume of the gas at STP conditions.

82.3.16 Evacuate the sample tube by turning the two-way stopcock on the mercury reservoir *M*, to vacuum and lowering the level of mercury in the side arm.

82.3.17 When a stable crucible blank of less than 0.01 cm³ is attained, turn off the induction generator and allow the crucible to cool.

82.3.18 Transfer the sample to the crucible by pushing it along the arm of the sample loader with an iron piece guided from outside with a magnet.

82.3.19 Close valve *V*₁, and start the induction generator to heat the crucible and sample to 1600° C.

82.3.20 Collect the evolved gases in the same manner as in the blank determination.

82.3.21 Turn off the induction generator and record the pressure and the temperature of the sample tube.

82.3.22 If a gas sample is desired for a gas composition analysis, remove the sample tube and transfer it to the desired analytical apparatus.

83. Calculation

83.1 Where the sample tube has been calibrated with a series of known volumes of gas calculate as follows: Use least-squares formulas to calculate the best linear equation relating the known volumes of gas in STP cm³ to the measured pressure in the sample tube, in torr, corrected to 273 K.

$$P_M = a + b (\text{STP cm}_1^3) \quad (15)$$

where:

- P_M = measured pressure, in torr, corrected to 273 K,
= $273 P_o / (T_o + 273)$,
- a = intercept of least-squares equation,
- b = slope of least-squares equation, and
- STP cm₁³ = known volume introduced corrected to 760 torr and 273 K,
= $(P_o / 760) \cdot [273 V_o / (273 + T_o)]$

where:

- P_o = observed pressure, torr,
- V_o = observed volume, cm³, and
- T_o = observed temperature, ° C.

Gas in sample per gram of sample:

$$\text{STP cm}_S^3/\text{g} = (P_S - P_B)/bW \quad (16)$$

where:

- STP cm_S³/g = cm³ of total gas per gram of sample, at 760 torr and 273 K,
- P_S = measured pressure for sample, in torr, corrected to 273 K,
- P_B = pressure for blank, in torr, corrected to 273 K,
- b = slope of least-squares equation, and
- W = sample mass, g.

83.2 Where the volume of the sample tube has been measured calculate the total gas content per gram of sample as follows:

$$\text{Total gas, STP cm}_S^3/\text{g} = [(273P_S V / 760 T_S) - (273P_B V / 760 T_B)] / W \quad (17)$$



where:

STP cm_S³/g = cm³ of total gas per gram of sample, at 760 torr and 273 K,

P_S = recorded pressure, torr, for sample,

V = measured volume, cm³, of sample tube,

T_S = recorded temperature of sample tube, for sample gas, K (°C + 273),

P_B = pressure, torr, for blank,

T_B = recorded temperature of sample tube for blank, K, and

W = mass of sample, g.

84. Precision and Bias

84.1 Since pellets with known volatile gas contents are not available, the bias of the test method is not known. Estimates of the precision, including the between-pellet variability, indicate a relative standard deviation of about 25 % at a level of approximately 0.050 cm³/g of sample at STP conditions.

TUNGSTEN BY DITHIOL-SPECTROPHOTOMETRY

85. Scope

85.1 This test method covers the determination of 5 to 150 µg of tungsten in 1-g samples of nuclear-grade uranium and plutonium mixed oxides (U, Pu)O₂(24).

86. Summary of Test Method

86.1 Tungsten is measured spectrophotometrically as the blue-green dithiol (3,4-dimercaptotoluene) complex (25, 26). Following its reduction to W(V), tungsten is complexed with dithiol and extracted into pentyl acetate from hot 8.4 M HCl. The absorbance of the dithiol complex is measured at 640 nm to determine the amount of tungsten.

87. Interference

87.1 Platinum and technetium interfere in concentrations of 100µ g/g, whereas lead and palladium interfere about the 1000-µg/g level; however, these elements are not routinely encountered in fuel materials. Molybdenum seriously interferes and must be separated by a preliminary extraction which is part of the test method (27).

NOTE 17—Separate the molybdenum by extracting the molybdenum-dithiol complex from 6 M HCl prior to the reduction of tungsten to W(V).

88. Apparatus

88.1 *Extraction Vessel*, consisting of a 25 by 150-mm test tube with a stopcock sealed to the bottom.

88.2 *Heater-Stirrer*,²⁶ and an aluminum block drilled with holes for 200-mL tall-form beakers.

88.3 *Platinum Dish*, 30-mL.

88.4 *Spectrophotometer*,²⁷ with matched 1.00-cm cells.

88.5 *Stirrer*, electric, with glass-propeller stirring rod.

89. Reagents

89.1 *Dithiol (3,4-dimercaptotoluene)*²⁸—Usually 1 g of the yellow crystalline material is sealed in a glass ampoule. Discard those ampoules which contain any yellow liquid.

89.2 *Dithiol-Pentyl Acetate Solution*—Prepare a 1 % solution of dithiol in pentyl acetate. Break an ampoule containing 1 g of dithiol under 100 mL of pentyl acetate and stir until dissolved. Prepare a fresh dithiol solution each day it is to be used (Note 18); store the solution at - 5 to 0° C.

NOTE 18—Test each freshly made solution by analyzing aliquots of the tungsten standard solutions because ampoules of dithiol may contain some decomposed reagent which will produce biased results.

89.3 *Hydrochloric Acid (12 M HCl, sp gr 1.19)*.

89.4 *Hydrochloric Acid (8.4 M)*—Dilute 70 mL of 12 M HCl to 100 mL with water.

89.5 *Hydrochloric Acid (6 M HCl)*—Dilute 50 mL of 12 M HCl to 100 mL with water.

89.6 *Hydrofluoric Acid (28 M HF)*.

89.7 *Hydrofluoric Acid (0.56 M HF)*—Dilute 2 mL of 28 M HF to 100 mL with water.

89.8 *Nitric Acid (15.6 M HNO₃, sp gr 1.42)*.

89.9 *Pentyl Acetate*—Redistill the pentyl acetate if it turns yellow when dithiol is dissolved in it.

89.10 *Potassium Pyrosulfate Powder*—(K₂S₂O₇).

89.11 *Sulfuric Acid (18 M H₂SO₄, sp gr 1.84)*.

89.12 *Titanium (III) Chloride Solution*—Pour 450 mL of 12 M HCl into a 500-mL volumetric flask, and add 10 mL of titanium tetrachloride (TiCl₄) below the surface of the HCl and mix. Add 12 g of stannous chloride dihydrate (SnCl₂·2 H₂O) and mix until dissolved. Dilute the mixture to volume with 12 M HCl and mix. When this blue solution starts to turn brown, prepare a new mixture.

89.13 *Tungsten Standard Solution (1 mL = 100µ gW)*—Dissolve 100 mg of tungsten metal in a minimum quantity of 28 M HF containing a few drops of 15.6 M HNO₃. Transfer the solution to a 1000-mL polypropylene volumetric flask and dilute to volume with 0.56 M HF.

89.14 *Tungsten Trioxide (WO₃)*.

90. Procedure

90.1 *Calibration*— Prepare at least five different blends of WO₃ in a mixed oxide matrix which covers the range from 5 to 150 µg of tungsten per gram of matrix material. Process each blend in duplicate starting at 91.1.

90.2 Use least-squares formulas to obtain the linear calibration equation, as follows, that best fits the calibration data.

$$Y = AX + B \quad (18)$$

where:

Y = absorbance,

X = micrograms of tungsten per grams of matrix material,

A = slope, and

B = intercept on the Y axis (B should be approximately zero (0)).

90.3 Determine the reagent blank by starting at 91.1. Process duplicate reagent blanks and use the average of the absorbance reading to correct the sample absorbance reading as indicated in 91.1.

90.4 Prepare a quality control chart for the values of A and B and verify the calibration by frequently processing duplicates of the calibration blend.

90.5 If an individual value of A' = Y/X disagrees at the 0.05 significance level with the value of A determined from the

²⁷ Beckman Model DU, obtained from Beckman Industries, Inc., Fullerton, CA, or equivalent, has been found satisfactory.

²⁸ Eastern Chemical Corp., Box AC, Pequannock, NJ 07740.



complete calibration set, correct the difficulty before proceeding with the analysis of samples.

91. Sample Analysis

91.1 Place a weighed mixed-oxide pellet in a mixture of 5 to 10 mL of 15.6 *M* HNO₃, 0.5 to 1 mL of 28 *M* HF, and 1 mL of 18 *M* H₂SO₄ in a 30-mL platinum dish and heat until the acids simmer.

NOTE 19—Do not boil the solution because loss by spattering will occur. An infrared lamp is recommended.

91.2 When the volume has decreased to approximately 2 mL, repeat the addition of 5 to 10 mL of 15.6 *M* HNO₃ plus 0.1 to 0.2 mL of 28 *M* HF and heat until the solution looks clear.

NOTE 20—The tungsten may not dissolve completely even though the solution looks clear. The steps given in 91.7 through 91.8 are intended to dissolve any tungsten-containing residue.

91.3 Decant the supernatant solution through a general-purpose filter (or equivalent) into a clean beaker.

91.4 Rinse the dish twice with 1 mL of water and transfer each rinse through the filter to the beaker.

91.5 Wash the filter with three 1-mL portions of water. Collect the washes in the beaker.

91.6 Transfer the filter to the platinum dish, dry, and carefully burn off the filter.

91.7 Add 0.5 g of K₂S₂O₇ to the dish and fuse over a burner or in a furnace until SO₃ fumes are no longer evolved. Tungsten is converted to a soluble sulfate salt.

91.8 After the dish cools, add approximately 5 mL of water and heat for 5 min to dissolve the fused salt. If dissolution is slow, add 1 mL of 15.6 *M* HNO₃.

91.9 Transfer the solution from the beaker to the dish with the aid of at least three 1-mL rinses of water.

91.10 Evaporate the combined solutions to dryness and fume until SO₃ fumes are no longer evolved.

NOTE 21—This step removes the nitrate, which otherwise would destroy the dithiol.

91.11 Redissolve the residue in 6 to 8 mL of 6 *M* HCl and transfer the solution to an extraction vessel.

91.12 Rinse the dish twice with 2-mL portions of 6 *M* HCl and add the rinses to the extraction vessel.

91.13 Adjust the volume in the extraction vessel to 12 mL with 6 *M* HCl.

91.14 Add 5 mL of pentyl acetate plus 5 mL of 1 % dithiol-pentyl acetate solution and stir for 3 min with an electric stirrer. Molybdenum extracts into the pentyl acetate.

91.15 After phase separation, drain the aqueous layer into a 200-mL tall-form beaker.

91.16 Wash the organic phase twice with 2.5-mL portions of 6 *M* HCl and add the acid washes to the beaker.

91.17 Add 25 mL of Ti(III) chloride solution to the beaker, 5 mL of water, and mix.

NOTE 22—The HCl concentration is now 8.4 *M*. Ti(III) reduces W(VI) to W(V).

91.18 Place the beaker in the aluminum block of the heater-stirrer preheated from 90 to 96° C and heat for 5 min.

NOTE 23—The solution must be hot to ensure complete formation of

the tungsten-dithiol complex.

91.19 Add 10 mL of 1 % dithiol-pentyl acetate solution and stir the mixture for 10 min while continuing to heat at 90° C. Tungsten extracts into the dithiol-pentyl acetate.

91.20 Remove the beaker from the aluminum block and allow the mixture to cool to room temperature.

91.21 Transfer the mixture to an extraction vessel, rinse the beaker with three 1-mL portions of pentyl acetate, and add these rinses to the extraction vessel.

91.22 Allow 5 to 8 min for the phases to separate. Drain the aqueous phase into a residue bottle.

91.23 Wash the organic layer twice with 5-mL portions of 8.4 *M* HCl, and add the washings to the residue bottle. Allow time for good phase separation.

91.24 Drain the organic phase into a 25-mL graduated cylinder, dilute to a volume of 15 mL with pentyl acetate, and mix well.

91.25 Transfer a portion of the dithiolpentyl acetate solution to a matched 1-cm absorption cell and measure the absorbance at 640 nm using pentyl acetate as the reference. Record the absorbance as *y*.

92. Calculation

92.1 Calculate the tungsten content as follows:

$$W, \mu\text{g/g} = (Z - B)/AW \quad (19)$$

where:

Z = absorbance of sample, *y*, corrected for the blank absorbance,

A, *B* = constants determined during calibration (90.2), and

W = grams of sample.

93. Precision and Bias

93.1 The relative standard deviation for mixed oxide pellets containing 50 to 60 μg/g of tungsten was 1.3 %, and at the 5 μg/g level was 15 % (28).

RARE EARTH ELEMENTS BY SPECTROSCOPY

94. Scope

94.1 This test method covers the determination of dysprosium, europium, gadolinium, and samarium in mixed oxides of uranium and plutonium over the concentration range from 0.1 to 10 μg/g of mixed oxide.

95. Summary of Test Method

95.1 (Pu, U)O₂ is dissolved in a nitric-hydrofluoric acid (HNO₃-HF) mixture and evaporated to dryness. The residue is redissolved in dilute HNO₃ and the uranium and plutonium are extracted into 30 % tributyl phosphate in *n*-hexane. The aqueous phase is treated with yttrium carrier and HF and the resulting rare earth precipitate separated by filtration. The fluoride precipitate is ignited, mixed with graphite, and excited with a d-c arc. An argon atmosphere containing approximately 20 % oxygen envelopes the electrode system. The spectra of samples and standards are recorded on photographic plates and concentrations are determined by visual comparison.

96. Interferences

96.1 Plutonium plus americium in excess of 3 mg in the separated fraction contribute high background and suppress rare earth element intensities.

96.2 Calcium and other alkaline earths interfere in concentrations in excess of 100 µg/g (Pu, U)O₂. Compensation for this interference may be made by the addition of appropriate amounts of interfering elements up to 1 mg/g to the standards before separation. This changes the detection limit for rare-earth elements to 0.15 µg/g (Pu, U)O₂.

97. Procedure

97.1 Determine the rare-earth element concentrations in (U, Pu)O₂ mixed oxide powders and pellets (in accordance with the procedure outlined in Sections 81 to 88 of Test Methods C 697).

PLUTONIUM-238 ISOTOPIC ABUNDANCE BY ALPHA SPECTROMETRY

98. Scope

98.1 This test method covers the determination of the plutonium-238 (²³⁸Pu) isotopic distribution in plutonium-uranium (PuU) samples. It is particularly useful for samples in which the plutonium-238 (²³⁸Pu) content is in the range from 0.01 to 1 %.

99. Summary of Test Method

99.1 The isotopic analysis of plutonium for the ²³⁸Pu isotope involves the prior separation of interferences. After dissolution of the sample the plutonium is separated from interferences by an anion exchange technique (29–31). Nitric acid, HNO₃(4 M) is used to adsorb the plutonium fraction on the resin and to elute interfering ions principally uranium and americium. The plutonium is then eluted with HNO₃ (0.5 M). Since an alpha-activity ratio is measured in the determination, quantitative recovery of the plutonium is not required. The alpha spectrum in the 5 to 6-MeV region is then obtained. The total counts in the ²³⁸Pu and the ²³⁹Pu + ²⁴⁰Pu peaks are obtained and corrected for background. The ²³⁸Pu abundance is calculated from the ratio of the alpha activity due to ²³⁸Pu and that due to the ²³⁹Pu + ²⁴⁰Pu. The abundance of ²³⁹Pu and ²⁴⁰Pu is determined by mass spectrometry on a separate portion of the purified sample.

100. Interferences

100.1 Americium-241, ²⁴¹Am, is always present as a result of ²⁴¹Pu decay and is a direct interference which must be removed prior to the determination of ²³⁸Pu. Other nuclides which would interfere such as ²³²U, ²⁴³Am, ²⁴⁵Cm, and ²⁴⁹Bk are not likely to be present following the separation. Uranium, while not a direct interference to the alpha-pulse height determination, can contribute a high-salt content to the sample mount which can decrease resolution of the alpha spectra and consequently decrease the sensitivity of the method. The uranium is an interference for the mass spectrometer analysis part of this procedure.

100.2 Alpha spectrometry is done within a day or two of the purification, especially if the abundance of ²⁴¹Pu is high, since ²⁴¹Am will grow in again from the beta decay of ²⁴¹Pu. However, if prompt analysis is not possible, suitable corrections for the bias due to ²⁴¹Am interference may be made up to a period of several weeks following the purification.

101. Apparatus

101.1 *Ion-Exchange Column*, disposable polyethylene (see Fig. 9). Enough glass wool is added to the column to hold the resin. Approximately 32 mm of converted resin (see Section 137) is added. The resin is then washed with 10 mL of 10 M HNO₃.

101.2 *Counting Disks*, polished platinum, tantalum, or stainless steel disks sized to fit the detection chamber. A disk 25 mm in diameter and 0.5 mm thick is commonly used.

101.3 *Alpha Spectrometer*—This should consist of the following components:

101.3.1 *Silicon Surface Barrier Detector*, with an active area of at least 100 mm², 100 µm or greater depletion depth, and a resolution of 20 keV or less full width at half maximum (FWHM) (for ²⁴¹Am 5.486 MeV alphas) is suitable. A detector with a rear microdot connector should be specified.

101.3.2 *Evacuatable, Light-Tight Chamber*,²⁹ in which the detector and the counting plate on its support can be mounted.

101.3.3 *Preamplifier*, charge-sensitive field effect transistor, with noise less than 4.6 keV when used with above detector (100 pF capacitance).

101.3.4 *Detector Bias Supply*, 0 to 1000 V, continuously variable, well-regulated and stable, with noise and ripple less than 0.0002 %.

²⁹ A simple but adequate chamber is commercially available from ORTEC or Tennelec, Oak Ridge, TN.

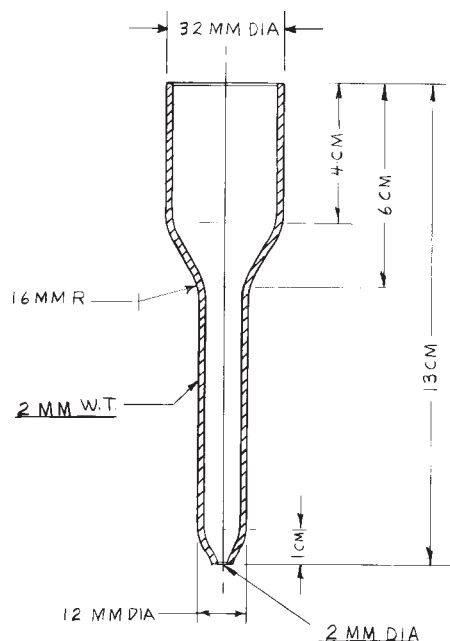

FIG. 9 Extraction Column

101.3.5 *Main Spectroscopy Amplifier*, low noise, with variable shaping constants and baseline restoration.

101.3.6 *Biased Amplifier and Pulse Stretcher*, with continuously adjustable post-gain and automatic pile-up rejection.

101.3.7 *Multichannel Pulse-Height Analyzer*—A multichannel analyzer is most versatile and convenient, since it can be used for the acquisition of data from one to four detectors simultaneously. Even if only one detector is used, such an analyzer has the advantage that background may be stored in another subgroup and subtracted electronically from the spectrum of interest, and that several spectra can be stored and compared. An analyzer that permits setting windows around the peaks of interest and electronic integration is especially convenient. The analyzer should accept pulses 0 to 10 V and 3–6 μ s in width, and should have a capacity of at least 10^6 – 1 counts full scale per channel.

101.3.8 *Teletype, Typewriter, or Other Peripheral Device*, may be used for output of the data from the multi-channel analyzer.

101.4 *Micropipets*, 50- μ L

101.5 *Infrared Heat Lamp*

102. Reagents and Materials

102.1 *Anion Exchange Resin*³⁰ (50–100 mesh), containing pyridinium exchange groups (basic resin-chloride ionic form), is prepared by washing thoroughly with 1 M sodium hydroxide (NaOH) solution until the resin turns dark brown in color. Then with 1 M nitric acid wash until the resin returns to its original yellow color. Repeat once and store in deionized water.

102.2 *Deionized Water*.

102.3 *Hydrofluoric Acid* (HF), concentrated.

102.4 *Hydrochloric Acid* (HCl), 6 M.

102.5 *Nitric acid* (HNO₃), 0.5 M, 1 M, 4 M, 10 M.

102.6 *Nitric Acid* (HNO₃) solution, concentrated.

102.7 *Sodium Hydroxide* (NaOH), 1 M.

103. Calibration of the Alpha Spectrometer

103.1 *Initial Alignment*—Set the biased amplifier so that channel zero is at about 5 MeV. Use a standard alpha source such as the 5.30 MeV particle of ²¹⁰Po, or the 5.49 MeV particle of ²⁴¹Am, for calibration. Establish the system gain at some convenient value, such as 5 keV/channel. Alternatively, a ²³⁸Pu-²³⁹Pu source may be used.

103.2 *Resolution*—Count the standard source and determine the energy span at half the peak height. A FWHM of 30 keV or less is desirable, but 50 keV can be tolerated.

103.3 *Background*—Obtain a background spectrum with a clean counting disk in the chamber.

103.4 *Frequency of Calibration*—The system gain and resolution should be checked periodically, in order to maintain the same operating conditions and to check whether any deterioration of the spectrometer has taken place. Daily background counting is advisable, to ensure that there has been no contamination of the chamber or detector.

104. Procedure

104.1 *Preparation of Sample:*

104.1.1 Weigh sufficient sample to provide 50 mg \pm 5 mg of plutonium. Transfer to a vial. Add 10 to 15 mL of 10 M HNO₃ and one drop of concentrated HF. Bring to slow boiling on a hot plate, at medium setting. The sample should be dissolved in approximately 1 h.

104.1.2 Transfer 250 μ L of the plutonium sample solution (1 mg Pu) to a freshly prepared ion exchange column (see 101.1 and 102.1).

104.1.3 Wash the ion exchange column with approximately 4 column volumes of 4 M HNO₃.

104.1.4 Elute the plutonium from the resin by washing with 10 mL of 0.5 M HNO₃.

104.1.5 If processing a mixed oxide sample containing greater than 50 % uranium add 10 mL of 10 M HNO₃ to the eluted sample, transfer the sample to a new ion exchange column, and repeat 104.1.3 and 104.1.4.

104.1.6 Mount 20 μ L or at least 1 μ g Pu from the elution on a counting disk and dry under a heat lamp.

104.1.7 Fire the disk by slowly heating the disk to dull redness in a flame.

104.1.8 Place the counting disk in the chamber of the alpha spectrometer and evacuate the chamber. Count the sample until there are at least 2500, and preferably 10 000, counts or more in the 5.50 MeV peak of ²³⁸Pu.

104.1.9 Obtain the total count for an equal number of channels over the ²³⁸Pu (5.50 + 5.46 MeV) peaks and the ²³⁹Pu + ²⁴⁰Pu (5.11 to 5.17 MeV). Subtract the background counts in the same channels, adjusted for the same counting time, from the total counts in the peaks, to obtain the net counts.

104.1.10 Using an aliquot from the purified sample obtained in 104.1.4 or 104.1.5, perform analysis for ²³⁹Pu, ²⁴⁰Pu, ²⁴¹Pu, and ²⁴²Pu by mass spectrometry in accordance with Sections 73 to 79 of Test Methods C 697.

104.1.11 Calculate the weight percent ²³⁸Pu as follows:

$$W_8 = \frac{C_8(W_9A_9 + W_0A_0)}{A_8C_9} \quad (20)$$

where:

W_8 = weight % of ²³⁸Pu,

W_9 = weight % of ²³⁹Pu from mass spectrometry (normalized),³¹

W_0 = weight % of ²⁴⁰Pu from mass spectrometry (normalized),³¹

A_8 = alpha specific activity of ²³⁸Pu,

A_9 = alpha specific activity of ²³⁹Pu,

A_0 = alpha specific activity of ²⁴⁰Pu,

C_8 = observed counts in ²³⁸Pu peaks, and

C_9 = observed counts in ²³⁹Pu peaks + ²⁴⁰Pu peak.

The specific activity of a nuclide is calculated from its half-life by the formula:

$$\text{Specific activity, (d/min)/}\mu\text{g} = \frac{7.942 \times 10^{11}}{At_{1/2}} \quad (21)$$

where:

³⁰ Bio Rad Laboratories "Bio-Rex 9" has been used successfully.

³¹ The mass spectrometry values for ²³⁹Pu, ²⁴⁰Pu, ²⁴¹Pu, and ²⁴²Pu should be normalized to 100 %.



A = atomic weight of the nuclide, and
 $t_{1/2}$ = half-life, years (see Table 4).

Units of the specific activity are disintegrations per minute – microgram. Table 4

105. Precision and Bias

105.1 The relative standard deviation of the test method for a single determination is $\pm 2\%$ or better, depending on the total integrated counts in each peak. The 2% figure is based on accumulating at least 2500 counts in the ^{238}Pu alpha peak for samples containing 0.01% of that isotope. For most samples, a much larger count will be accumulated in this peak, with correspondingly better precision. The inaccuracy with which the half-lives of the plutonium isotopes are known constitutes a bias of the test method.

AMERICIUM 241 IN PLUTONIUM BY GAMMA-RAY SPECTROMETRY

(Test Method C 1268 may be used for the determination of Americium 241 in plutonium.)

URANIUM AND PLUTONIUM ISOTOPIC ANALYSIS BY MASS SPECTROMETRY

106. Scope

106.1 This test method covers the determination of the isotopic composition of uranium and plutonium in nuclear-grade mixed oxides ((U, Pu) O_2).

107. Summary of the Test Method

107.1 The uranium and plutonium are separated from each other and purified from other elements that would interfere by selective extraction or anion exchange purification. The uranium and plutonium fractions are individually mounted and dried on rhenium filaments. Tungsten or tantalum filaments may be substituted with minor modifications in the procedure. The prescribed ion beam and intensity are obtained, the spectrum is scanned, the peaks are recorded, and the relative abundances of the isotopes are calculated (32).

NOTE 24—For the highest precision and bias, all steps of the mass spectrometric analytical procedure must be strictly adhered to in order to maintain the same experimental conditions for all analyses. Failure to be consistent will have a direct effect on the observed data and will be detrimental to the precision and bias of the ratio measurement. Steps

TABLE 4 Principal Alpha Peaks of Interest^A

Nuclide	$t_{1/2}$, years	Alpha-Particle Energy, MeV	Alpha-Particle Abundance, percent
^{238}Pu	87.75	5.50	72
		5.46	28
^{239}Pu	24 400	5.16	73.3
		5.14	15.1
		5.11	11.5
^{240}Pu	6,540	5.17	76
		5.12	24
		5.09	86
^{241}Am	433	5.44	12.7
		5.40	1.3

^AData taken from Ref (31). Half-lives have been updated to values accepted as of July 1974. Peaks of low abundance (less than 0.1) have been omitted.

included are sample preparation, sample mounting, sample degassing, and the heating pattern for obtaining ion emission for the ratio measurements.

108. Interferences

108.1 Uranium-238 and ^{238}Pu interfere in the measurement of the other and ^{241}Am interferes with the measurement of ^{241}Pu , thereby requiring chemical separation. Separation of other components provides uniform ionization of uranium or plutonium, hence improved precision, and reduces the interference from molecular species of the same mass number as the uranium or plutonium isotopes being measured.

109. Apparatus

109.1 *Mass Spectrometer*—A typical mass spectrometer laboratory would have 305-mm (12-in.) radius of curvature, 60 or 90° sector, single or double focusing, and single- or multiple-filament thermal ionization instruments designed for isotopic abundance measurements on high-atomic mass elements. Resolution and abundance sensitivity specifications are dictated by the end performance desired of the instrument. In general, a typical (33), (34) well-designed single-stage mass spectrometer should resolve adjacent masses in the 230 to 245 mass range with less than 1×10^{-4} interaction between tails. Abundance sensitivities of less than 1 in 20 000 should be obtained.

109.2 The mass spectrometer should also be equipped with the following: a collector that adequately suppresses electrons; an expanded scale strip-chart recorder; or a suitable scaler-timer and voltage-to-frequency converter combination for digital measurements. Without this type of measuring circuit, the limit of error for a ratio measurement is ± 0.5 relative %.

109.3 An *Optical Pyrometer* should be available to determine the filament temperature.

110. Reagents

110.1 *Anion Exchange Resin* ³²

110.2 *Ethylenediamine Tetraacetate (EDTA) Solution (0.03 M)*—Dissolve 1.12 g of disodium ethylenediamine tetraacetate dihydrate (EDTA) in 90 mL of water, adjust the pH to 7, and dilute to 100 mL with water.

110.3 *Ferrous Sulfamate Solution (3.2 M)*—Dissolve 794 g of ferrous sulfamate ($\text{Fe}(\text{NH}_2\text{SO}_3)_2$) in water and dilute to 1 L.

110.4 *Hydrochloric Acid (2 M)*—Dilute 17 mL of hydrochloric acid (HCl, sp gr 1.19) to 100 mL with water.

110.5 *Hydrochloric Acid (12 M)*—The hydrochloric acid must be at least 12 M and can be prepared by bubbling hydrogen chloride gas through hydrochloric acid of lower concentrations. Determine the molarity by titration with a standard base.

110.6 *Hydrochloric-Hydriodic Acid Mixture (12 M HCl-0.1 M HI)*—This mixture must be made just before use. Add a calculated amount of hydriodic acid to 12 M HCl (146.15). The hydriodic acid must be free of hypophosphorus acid that is used as a preservative in reagent grade hydriodic acid. This can be done by distilling the hydriodic acid.

³² Bio-Rad AGMP-1, 50–100 mesh, has been found satisfactory.



110.6.1 **Caution**—To avoid danger of explosions, hydriodic acid should be distilled only in an inert atmosphere. Determine the molarity of the hydriodic acid by titration with a standard base.

110.7 *Hydrofluoric Acid (1 M)*—Dilute 1 mL of hydrofluoric acid (HF, sp gr 1.18) to 29 mL with water.

110.8 *Hydroxylamine Hydrochloride Solution (5 M)*—Dissolve 348 g of hydroxylamine hydrochloride (NH₂OH·HCl) in water and dilute to 1 L.

110.9 *Nitric Acid (0.75 M)*—Dilute 4.8 mL of nitric acid (HNO₃, sp gr 1.42) to 100 mL with water.

110.10 *Nitric Acid (1 M)*—Dilute 6.3 mL of nitric acid (HNO₃, sp gr 1.42) to 100 mL with water.

110.11 *Nitric Acid (8 M)*—Dilute 50 mL of nitric acid (HNO₃, sp gr 1.42) to 100 mL with water.

110.12 *Nitric-Hydrofluoric Acid Mixture (15 M HNO₃-0.05 M HF)*—Add 0.9 mL of hydrofluoric acid (HF, sp gr 1.15) to 485 mL of nitric acid (HNO₃, sp gr 1.42) and dilute to 500 mL with water.

110.13 *Perchloric Acid (1 M)*—Dilute 17 mL of perchloric acid (HClO₄, sp gr 1.67) to 200 mL with water.

110.14 *Perchloric Acid (6 M)*—Dilute 5 mL of perchloric acid (HClO₄, sp gr 1.67) to 10 mL with water.

110.15 *Sodium Hydroxide (4 M)*—Dissolve 16 g of sodium hydroxide in 80 mL of water and dilute to 100 mL with water.

110.16 *Sodium Nitrite Solution (2 M)*—Dissolve 138 g of sodium nitrite (NaNO₂) in water and dilute to 1 L.

110.17 *Thenoyltrifluoroacetone (0.5 M)*—Dissolve 110 g of thenoyltrifluoroacetone (TTA) in xylene and dilute to 1 L with xylene.

111. Calibration of the Mass Spectrometer

111.1 *Mass Discrimination*—The measurement and correction for mass discrimination is a critical factor in obtaining precise and accurate results. Equally critical to the accuracy of the measurement is the linearity of the total measuring circuit, including the collector. Calibration of the mass spectrometer is based upon the assumption that these are the only two sources of significant (>1 in 10⁻⁴) systematic error in the measurement. Thus, accurate calibration is made by analyzing standards of known isotopic composition under conditions in which cross-contamination between samples does not occur.

111.2 The recommended calibration standard, for determination of mass discrimination to be used to correct both uranium and plutonium ratios, is NIST SRM U500 (Note 25). The deviation from the certified value is a measure of the mass discrimination of the spectrometer for a three mass unit difference. Using the ²³⁵U/²³⁸U mass discrimination factor, the mass discrimination is then calculated for each ratio and mass range to be calibrated. The ²³⁵U/²³⁸U mass discrimination factor, *B*, is calculated as follows:

$$B = (1/\Delta M)[(\bar{R}/R_s) - 1] \quad (22)$$

where:

- B* = mass discrimination factor,
- ΔM = mass unit difference = (238-235),
- R_s* = certified value of SRM, and

\bar{R} = average measured value of ²³⁵U/²³⁸U for *n* different analyses.

At the 95 % confidence level, the mass discrimination correction for ²³⁵U/²³⁸U can, under ideal conditions, be determined with a precision that is equal to or less than 2 in 10 000.

NOTE 25—Corrections for mass discrimination of plutonium are made by assuming that under equivalent analytical conditions the mass-dependent isotopic fractionation effects for uranium and plutonium are identical. This method of calibrating for plutonium mass discrimination is highly dependent upon establishing equivalency of analytical conditions and can be subject to significant systematic errors. Although plutonium isotopic SRMs available from NIST, certified relative to uranium, present some unfavorable factors, magnitude of the ²³⁹Pu/²⁴⁰Pu ratios and the small (one) mass difference, for the most precise and accurate mass discrimination determination; it is an attractive alternative that establishes a common measurement base using plutonium.

111.3 *Linearity*—The linearity of the mass spectrometer may be determined over the ratio range from 0.1 to 10, 0.05 to 20, or 0.005 to 200 by measuring the ²³⁵U/²³⁸U, under identical analytical conditions, of NIST SRMs U100-U500-U900, SRMs U050 through SRM U930, or SRMs U005 through U970, respectively. The ratio of the certified ²³⁵U/²³⁸U ratio to the experimental ²³⁵U/²³⁸U ratio is a dimensionless number and is independent of isotopic ratio, if the system is linear. Under ideal conditions, any deviation from a constant value greater than 4 in 10 000 is likely to be nonlinearity. Only uranium SRMs are used because the range of isotopic ratios of existing plutonium SRMs is not adequately large.

112. Procedure

112.1 *Sample Preparation*—Dissolve a few milligrams of sample in 15 M HNO₃-0.05 M HF mixture by heating. Dilute the sample solution in enough 1 M HClO₄ to give a solution containing 100 µg Pu/mL.

112.2 *Separation of Plutonium and Uranium by Solvent Extraction:*

112.2.1 Take an aliquot of the sample solution containing 10 µg of Pu and evaporate to dryness.

112.2.2 Dissolve the residue in 2 M HCl; heat slightly, if necessary.

112.2.3 Add 10 µL of ferrous sulfamate solution and 50 µL of 5 M hydroxylamine hydrochloride. Digest for 5 min at 80°C.

112.2.4 Add 2 mL of 0.5 M TTA, stir for 2 min, and centrifuge the sample. Transfer the aqueous phase to a clean vial.

112.2.5 Add 500 µL of 2 M NaNO₂ and digest for 5 min at 80°C.

112.2.6 Add 2 mL of 0.5 M TTA, stir for 2 min, and centrifuge the sample. Transfer the TTA phase (Pu fraction) to a clean vial.

112.2.7 Save the aqueous phase (U fraction) and continue with it in 112.2.13.

112.2.8 To the TTA phase, add 2 mL of 1 M HNO₃, stir for 2 min, centrifuge, and transfer the TTA phase to a clean vial.

112.2.9 Repeat 112.2.8.

112.2.10 Add 1 mL of 8 M HNO₃, stir for 2 min, centrifuge, and transfer the aqueous phase to a clean vial.

112.2.11 Evaporate the solution to dryness by heating the vial on an aluminum block at 120°C.



112.2.12 Dissolve the plutonium residue in 0.5 mL of 0.75 M HNO₃ and reserve for 112.4.

112.2.13 To the aqueous phase from 112.2.7, add 200 µL of 5 M NH₂OH·HCl. Digest for 5 min at 80°C.

112.2.14 Add 1.0 mL of 0.03 M EDTA and 1 drop of methyl violet indicator solution.

112.2.15 Add 4 M NaOH until the solution turns blue, then add one more drop.

112.2.16 Add 2 mL of 0.5 M TTA, stir for 2 min, and centrifuge.

112.2.17 Transfer the TTA phase to a clean vial, add 1.0 mL of 1 M HNO₃, stir for 2 min, and centrifuge.

112.2.18 Transfer the aqueous phase to a clean vial, add 4 drops of HClO₄, and evaporate to dryness.

112.2.19 Dissolve the uranium residue in enough 0.75 M HNO₃ to give a solution containing 1 mg U/mL and reserve for 112.5.

112.3 *Separation of Uranium and Plutonium by Ion Exchange (35):*

112.3.1 Add 10 drops of 6 M HClO₄ and 10 drops of 1 M HF to an aliquot of the sample solution (147.1) containing approximately 100 µg of uranium or 30 µg of plutonium, or both, and evaporate to dryness.

112.3.2 Dissolve the residue in 0.5 mL of 12 M HCl and transfer with the aid of a 0.5-mL rinse of 12 M HCl to the prepared column.

NOTE 26—Prepare a column as follows: place a glass or plastic wool plug in the bottom of a 6 by 60-mm column. Slurry the resin in water and pour the resin into the column, avoiding formation of air bubbles, until the resin is 50 mm in height. Condition the column just before use by passing 5 mL of 12 M HCl through the column.

112.3.3 Elute the americium with 4 mL of 12 M HCl and discard.

112.3.4 Elute the plutonium with 4 mL of 12 M HCl-0.1 M HI, evaporate to dryness, and continue with the plutonium fraction in 112.3.8.

112.3.5 Wait 10 min to ensure complete reduction of any residual plutonium and add 6 mL of 12 M HCl-0.1 M HI to the column to remove the traces of plutonium.

112.3.6 Add 0.5 mL of 0.1 M HCl to the column and discard.

112.3.7 Elute the uranium with 4 mL of 0.1 M HCl and evaporate to dryness.

112.3.8 Add 0.5 mL of 15.4 M HNO₃ to the plutonium residue (112.3.4) and to the uranium residue (112.3.7) and fume to dryness to expel chloride and destroy any organic matter.

112.3.9 Repeat 112.3.8.

112.3.10 Dissolve the plutonium residue in enough 0.75 M HNO₃ to give a solution containing 20 µg Pu/mL and dissolve the uranium residue in enough 0.75 M HNO₃ to give a solution containing 1 mg U/mL.

112.4 *Mass Spectrometer Measurement of Plutonium:*

112.4.1 Mount the sample by placing 10 µL of plutonium solution (112.2.12 or 112.3.10), containing 0.2 µg of plutonium, on each suitably prepared 0.031 by 0.762-mm (0.0012 by 0.030-in.) rhenium sample filament (Note 28) and evaporate to dryness with a heat lamp and electrical current adjusted in

the following manner: 1 A for 10 min, 1.3 A for 3 min, and slowly increase the filament current to a maximum, usually 1.8 to 2.2 A in air, that is safely below red-heat (approximately 600°C). The temperature of the filament during the final stages of sample mounting is a critical factor and must be carefully controlled to prevent significant variations.

NOTE 27—The rhenium filaments may be cleaned by heating in 5 M HCl for several hours to remove surface contaminants, then rinsed in high purity water and dried in a clean air environment. The final cleaning, which is the minimum recommended, is degassing in a vacuum station and under a potential field for ½ h at approximately 2000°C.

112.4.2 Insert filament assembly into the mass spectrometer and obtain a source pressure of less than 400 µPA (3×10^{-6} torr).

112.4.3 Degas by adjusting the ionizing filament temperature to 2140°C and set the sample filament currents at 1.5 A. After 3 min of heating, readjust the ionizing filament temperature to 2140°C and set the sample filament currents at 1.7 A. After 15 min of heating, turn off all filaments and allow to cool for 30 min for high-accuracy measurement and for 15 min for production analyses.

NOTE 28—Sample degassing may be considered optional for plutonium isotope analysis but is strongly recommended for high reliability. Degassing is considered essential for measurements with high-sensitivity electron detectors where low-level interference from organic and inorganic molecules is a major problem. Degassing is also essential with conventional faraday cup detectors when there are small amounts of organic or inorganic impurities.

112.4.4 *Heating Pattern and Isotopic Ratio Measurement:*

112.4.4.1 During the first minute, adjust the ionizing filament temperature to 2140°C, set the sample filament currents at 1.5 A, locate the ¹⁸⁷Re peak, and focus for maximum intensity.

NOTE 29—The ¹⁸⁷Re signal is normally 1.5 to 1.8×10^{-11} A and decaying. If the rhenium signal is unstable or erratic, the analysis should be terminated. The most probable causes of an unstable signal are a defective filament, large alkali background, and electronic instability.

112.4.4.2 At 5 min, readjust the ionizing filament temperature to 2140°C. Increase the sample filament currents to yield a Pu⁺ signal of 2×10^{-12} A. Focus for maximum signal intensity.

112.4.4.3 At 10 min, adjust the sample filament currents to yield a Pu⁺ signal of 5×10^{-12} A. Focus for maximum signal intensity.

112.4.4.4 At 15 min, check the ionizing filament temperature and adjust to 2120°C if necessary.

112.4.4.5 At 20 min, adjust the sample filament currents to yield a Pu⁺ signal of 1×10^{-11} A.

112.4.4.6 At 25 min, readjust, if necessary, the sample filament currents to yield a Pu⁺ signal of 1×10^{-11} A. Focus for maximum intensity. Determine baselines for ²³⁹Pu and ²⁴⁰Pu (See Note 32).

112.4.4.7 At 30 min, start the ratio measurement (Note 30). The Pu⁺ signal intensity should be approximately 1.0 to 1.2×10^{-11} A and slowly changing. For complete isotopic characterization measure the ratios (Note 31) on a strict time schedule that is the same for each analysis and in the following sequence: ²³⁹Pu/²⁴⁰Pu; ²⁴¹Pu/²⁴⁰Pu; ²⁴²Pu/²⁴⁰Pu; ²³⁸Pu/²⁴⁰Pu;



$^{242}\text{Pu}/^{240}\text{Pu}$; $^{241}\text{Pu}/^{240}\text{Pu}$; $^{239}\text{Pu}/^{240}\text{Pu}$. Exception to the recommended ratio sequence is suggested when the measurement uncertainty of the isotopic ratio is very large with respect to the mass discrimination factor. For many samples, the ratio sequence may be changed to: $^{239}\text{Pu}/^{240}\text{Pu}$; $^{241}\text{Pu}/^{240}\text{Pu}$; $^{242}\text{Pu}/^{240}\text{Pu}$; $^{241}\text{Pu}/^{240}\text{Pu}$; $^{239}\text{Pu}/^{240}\text{Pu}$; and then measure $^{238}\text{Pu}/^{240}\text{Pu}$. The number of ratio sets per ratio determination can be varied but will usually fall within the range from 7 to 10. The number of ratio sets is determined by the point at which the internal standard deviation is smaller than the external or between-filament standard deviation.

NOTE 30—The “peak-hopping” technique of ratio measurements is normally preferred to the “mass-scanning” technique. Baselines are therefore determined immediately before or after each ratio determination within the analysis, or both. If there is significant baseline drift or resolution problems, then mass scanning must be used.

NOTE 31—The peak top observation time is governed by many factors including: response of the measuring circuit; emission stability; rate of signal decay; settling time of magnet switching circuit; and desired precision and accuracy of the measurement. For most systems equipped with vibrating reed electrometers, there is a minimum delay of 5 s for circuits to stabilize after peak switching occurs in the ratio range from 0.05 to 20. Outside of this range, longer delay times may be required to minimize the effects of system response and should be determined for each measuring circuit/mass spectrometer.

112.5 Mass Spectrometer Measurement of Uranium:

112.5.1 Mount the sample by placing 10 μL of uranium solution (112.2.19 or 112.3.10), containing 10 μg of uranium, on each suitably prepared 0.031 by 0.762-mm (0.0012 by 0.030-in.) rhenium sample filament (Note 27) and evaporate to dryness with a heat lamp and an electrical current adjusted in the following manner: 1 A for 10 min, 1.3 A for 3 min, and slowly increased until the yellow-orange oxide forms (1.8 to 2.2 A). If the color change cannot be detected, exercise extreme caution to avoid temperatures significantly greater than 600°C. The temperature of the filament during the final stages of sample mounting is a critical parameter and can produce a significant bias between runs, if not carefully controlled.

112.5.2 Insert the filament assembly into the mass spectrometer and obtain a pressure of less than 400 μPa (3×10^{-6} torr).

112.5.3 Degas by adjusting the ionizing filament temperature to 2140°C and set the sample filament currents at 1.5 A. After 3 min of heating, readjust the ionizing filament temperature to 2140°C and set the sample filament currents at 1.8 A. After 15 min of heating, turn off all filaments and allow to cool for 30 min for high-accuracy measurement and for 15 min for production analyses.

112.5.4 Heating Pattern and Mass Spectrometer Ratio Measurements:

112.5.4.1 During the first minute, adjust the ionizing filament temperature to 2140°C, set the sample filament currents at 1.5 A, locate the ^{187}Re peak, and focus for maximum intensity (Note 29).

112.5.4.2 At 5 min, increase the sample filament currents to yield a $1 \times 10^{-11}\text{A U}^+$ signal and adjust focus controls for maximum intensity.

112.5.4.3 At 10 min, adjust the sample filament currents to yield a $2 \times 10^{-11}\text{A U}^+$ signal and focus for maximum intensity.

112.5.4.4 At 15 min, check the ionizing filament temperature and adjust to 2120°C if necessary.

112.5.4.5 At 20 min, adjust the sample filament currents to yield a $4 \times 10^{-11}\text{A U}^+$ signal and focus for maximum intensity.

112.5.4.6 At 25 min, readjust, if necessary, the sample filament currents to yield a $4 \times 10^{-11}\text{A U}^+$ signal. Focus for maximum intensity and then determine baselines for ^{235}U and ^{238}U .

112.5.4.7 At 30 min, start the ratio measurement (Note 30). The U^+ signal intensity should be approximately $4 \times 10^{-11}\text{A}$ and slowly growing. For complete isotopic characterization measure the ratios (Note 31) on a strict time schedule that is the same for each analysis and in the following sequence: $^{235}\text{U}/^{238}\text{U}$; $^{234}\text{U}/^{235}\text{U}$; $^{236}\text{U}/^{235}\text{U}$. For a major isotope characterization, the ratio sets per ratio determination can be varied but will usually fall within the range from 7 to 10. The number of ratio sets is determined by the point at which the internal standard deviation is smaller than the external or between-filament standard deviation.

113. Calculation

113.1 *Averaging Peak Intensities*—Obtain the peak intensity for a single ratio by subtracting the average baseline reading from the average peak heights of a set of three peaks. The averages for the peak heights are taken at the center of time for the set and consists of two peaks for one isotope and one peak for the other. The ratios of the determination are calculated using a “dependent” set in which all peaks are used twice in the calculation, exclusive of the first and last. The “independent” set in which all peaks are used only once in the calculation is not preferred because a significant amount of data is rejected; the ratio is biased when the ion emission is nonlinear or the rate of change is great.

NOTE 32—For automated and semiautomated systems, the baseline and peak height determinations are performed by a computer. However, the basic principles are the same whether the ratios are determined manually from a strip-chart recorder or by computer. The ^{239}Pu and ^{240}Pu or ^{235}U and ^{238}U baselines are the average of the initial and final low-mass and high-mass reading. Usually, the initial and final $^{239}\text{Pu}/^{240}\text{Pu}$ or $^{235}\text{U}/^{238}\text{U}$ baseline values will not differ significantly. It can be observed that the low-mass baseline value is always slightly greater than the high-mass value. For most ratios, this difference is not a significant source of bias. In those instances where averaging this difference is significant, the baseline must be determined at a point in the spectrum or on the high-mass side of each peak. Because of possible scatter tails, the proper background zero for the other low-abundance isotopes is estimated as follows:

$$LMZ + (1/5)[HMZ - LMZ] \quad (23)$$

where:

LMZ = low-mass baseline, and

HMZ = high-mass baseline.

113.2 The average raw isotopic ratios are obtained from the ratios calculated by interpolation by use of appropriate scale factors and are designated as follows:

$$^{239}\text{Pu}/^{240}\text{Pu} = \bar{R}_{90}$$

$$^{241}\text{Pu}/^{240}\text{Pu} = \bar{R}_{10}$$

$$^{242}\text{Pu}/^{240}\text{Pu} = \bar{R}_{20}$$

$$^{238}\text{Pu}/^{240}\text{Pu} = \bar{R}_{80}$$

and

$$\begin{aligned} {}^{235}\text{U}/{}^{238}\text{U} &= \bar{R}'_{58} \\ {}^{234}\text{U}/{}^{235}\text{U} &= \bar{R}'_{54} \\ {}^{236}\text{U}/{}^{235}\text{U} &= \bar{R}'_{65} \end{aligned}$$

113.3 The final isotopic ratios are corrected for mass discrimination as follows:

$$\begin{aligned} R' &= [\bar{R}/(1 + CB)], \text{ since } B \\ &= 1/\Delta M[(\bar{R}/R_s) - 1] \text{ then } 1 + \Delta MB \\ &= \bar{R}/R_s \end{aligned} \quad (24)$$

where:

- R' = final isotopic ratio corrected for mass discrimination,
- \bar{R} = average raw ratio,
- ΔM = mass unit difference,
- B = mass discrimination factor as determined in 111.2, and
- \bar{R} = average measured value of ${}^{235}\text{U}/{}^{238}\text{U}$ for n different analyses.

113.4 Calculate the atom and mass percent for all isotopes as follows:

$$\text{Atom } \%, A = 100 \bar{R}' / (1 + \bar{R}'_{90} + \bar{R}'_{10} + \bar{R}'_{20} + \bar{R}'_{80})$$

$$\text{Mass } \%, W_m = 100 M \bar{R}' / (240.05 + 239.05 \bar{R}'_{90} + 241.06 \bar{R}'_{10} + 242.06 \bar{R}'_{20} + 238.05 \bar{R}'_{80})$$

and

$$\text{Atom } \%, A = 100 \bar{R}' / (1 + \bar{R}'_{48} + \bar{R}'_{58} + \bar{R}'_{68})$$

$$\text{Mass } \%, W_m = 100 M \bar{R}' / (238.05 + 234.04 \bar{R}'_{48} + 235.04 \bar{R}'_{58} + 236.05 \bar{R}'_{68})$$

where:

- A = atom percent of a given isotope, and
- \bar{R}' = average corrected ion current ratio of the given isotope to the ${}^{240}\text{Pu}$ or ${}^{238}\text{U}$ isotope. (Note that \bar{R}' for ${}^{240}\text{Pu}$ or ${}^{238}\text{U}$ is equal to 1.) $\bar{R}'_{48} = \bar{R}'_{45} \times \bar{R}'_{58}$; $\bar{R}'_{68} = \bar{R}'_{65} \times \bar{R}'_{58}$.
- W_m = mass percent for isotopes, m ,
- W = mass percent of a given isotope, and
- M = nuclidic mass of the given isotope.

114. Precision and Bias

114.1 *Precision*—The ultimate precision and bias of isotopic ratio measurements by thermal ionization mass spectrometry requires consideration of factors that are not necessarily readily apparent in the description of the test method. It is assumed that these factors are under rigid control during high-precision and high-accuracy measuring conditions. Since control of these factors may be relaxed during routine or production analyses, the precision of the test method is given for two sets of laboratory conditions.

Plutonium		
Ratio	95 % Confidence Limit for High-Precision Conditions, %	95 % Confidence Limit for Production Conditions, %
1	0.02	0.05 to 0.2
100	0.1 to 0.2	0.2 to 0.5
200	0.3 to 0.5	0.5 to 1.0
500	0.5 to 1	1 to 3
1000	2 to 4	5 to 10
Uranium		

Ratio	95 % Confidence Limit for High-Precision Conditions, %	95 % Confidence Limit for Production Conditions, %
1	0.02	0.05 to 0.2
100	0.02 to 0.05	0.1 to 0.3
200	0.1 to 0.2	0.2 to 0.5
500	0.3 to 0.5	0.3 to 1.0
1000	1 to 2	3 to 5

114.2 *Bias*—The accuracy of an isotope ratio measurement, under ideal conditions where synthetic calibration mixes are prepared from high-purity separated isotopes, is obtained by the summation of three uncertainty components: mass spectrometric analytical error (precision of the ratio measurement); possible systematic error in the composition of separated isotopes; and possible systematic error in chemical analysis. Under these conditions and with the most favorable isotopic ratio of unity, the accuracy will normally fall between 0.03 and 0.07 relative %.

114.2.1 *Plutonium*—Until the uncertainty components for plutonium are properly evaluated, the accuracy is estimated to be within 0.15 % for the ratio range from 1 to 20. Outside of this range, the increased imprecision of the ratio measurement and the analytical conditions, high accuracy versus routine, will normally require larger limits for the accuracy.

NOTE 33—The assumption that uranium and plutonium have the same mass discrimination factor under identical or equivalent analytical conditions, or both, is tenuous because of the difficulty in defining these conditions and obtaining the proper relationship. Unless these conditions are accurately produced, there can be systematic errors of 0.2 % per mass unit in the mass discrimination factor. This systematic error is due to variable isotopic fractionation for different analytical conditions and can be demonstrated to range from less than zero to nearly 0.2 % per mass unit for uranium. Approximately the same magnitude can be obtained for plutonium by changing the analytical conditions of the mass spectrometry. Based upon these experimental data, the uncertainty in the accuracy for the most precise plutonium ratio measurement must be larger until proper calibration using synthetic calibrating standards is performed.

114.2.2 *Uranium*—When SRMs calibrated by synthetic standards are utilized under high-accuracy laboratory conditions to calibrate the isotopic ratios of uranium extracted from fuel rods or pellets, the estimated accuracy under favorable ratio conditions is 0.1 to 0.2 relative %. For production or routine analysis, the mass spectrometric analytical error is greater and the possible systematic error in the chemical preparation of the analyte samples is not only greater but usually undetermined in magnitude. For this type of analysis, the estimated accuracy of a favorable ratio will fall between 0.2 and 1.0 relative %.

OXYGEN-TO-METAL ATOM RATIO BY GRAVIMETRY

115. Scope

115.1 This test method covers the determination of the oxygen-to-metal atom ratio (O/M) in sintered mixed oxide pellets and powders.

116. Summary of Test Method

116.1 The sample is weighed before and after heating under conditions that are reported by McNeilly and Chikalla to produce a stoichiometric oxide (ratio = 2.000) (36). These

conditions are heating at 800°C for a minimum of 6 h in an atmosphere of hydrogen-helium saturated with water vapor at 0°C. The O/M is calculated from the weight change.

117. Interferences

117.1 Depending upon the contents and natures of impurities in the sample, the weight change during analysis may be affected by loss of volatile impurities or by oxidation or reduction of impurities. High concentrations of inert impurities would also reduce the weight change. The O/M values obtained should be evaluated considering possible biases caused by impurities.

118. Apparatus

118.1 *Analytical Balance*, capable of weighing within ±0.1 mg or better.

118.2 *Moisture Analyzer*, capable of measuring water contents of argon or helium to less than 20 ppm. A Panametrics probe has been found satisfactory for this purpose.

118.3 *O/M Apparatus*— See Fig. 10.

119. Reagents

119.1 *Argon (A)*, prepurified grade (37) or equivalent, <20 ppm water. Test water content with a moisture analyzer to assure that the level is less than 20 ppm.

119.2 *Helium (He)*, high purity grade (37) or equivalent, <20 ppm water. Test water content with a moisture analyzer to assure that the level is less than 20 ppm.

119.3 *Hydrogen-Helium Mixture*, 6 % hydrogen, prepared from prepurified grade (37) or equivalent gases.

119.4 *Ice*.

119.5 *Magnesium Perchlorate* Mg—(ClO₄)₂, anhydrous, for the drying tube in the O/M apparatus.

120. Safety Precautions

120.1 Because of the toxicity of plutonium, all operations should be performed within an approved glove box fitted with appropriate filters to contain any small particles of plutonium. A detailed discussion of the necessary precautions is beyond the scope of these test methods. Personnel involved in these analyses should be familiar with safe handling practices (1, 2, 3).

121. Procedure

NOTE 34—This test method is based on a one-step heating cycle. Other thermogravimetric methods using a two-step heating cycle are also satisfactory for this analysis (38, 39).

121.1 Pellets

121.1.1 Adjust the flow rate of the hydrogen-helium (B) (see Fig. 10) to 300 to 500 mL/min, adjust valves so that the gas passes through the water bubbler (F), add ice to the Dewar flask (G), turn on the furnace (J), and adjust its temperature to 800°C.

121.1.2 Heat the boats (L) under the above conditions for 1 h, remove the furnace tube from the furnace to allow rapid cooling, and allow the boats to cool to room temperature in the hydrogen-helium atmosphere.

121.1.3 Remove the boats from the furnace tube, weigh each within ±0.1 mg, and repeat 121.1.2 and 121.1.3 until a constant tare weight (W_T) is obtained for each empty boat.

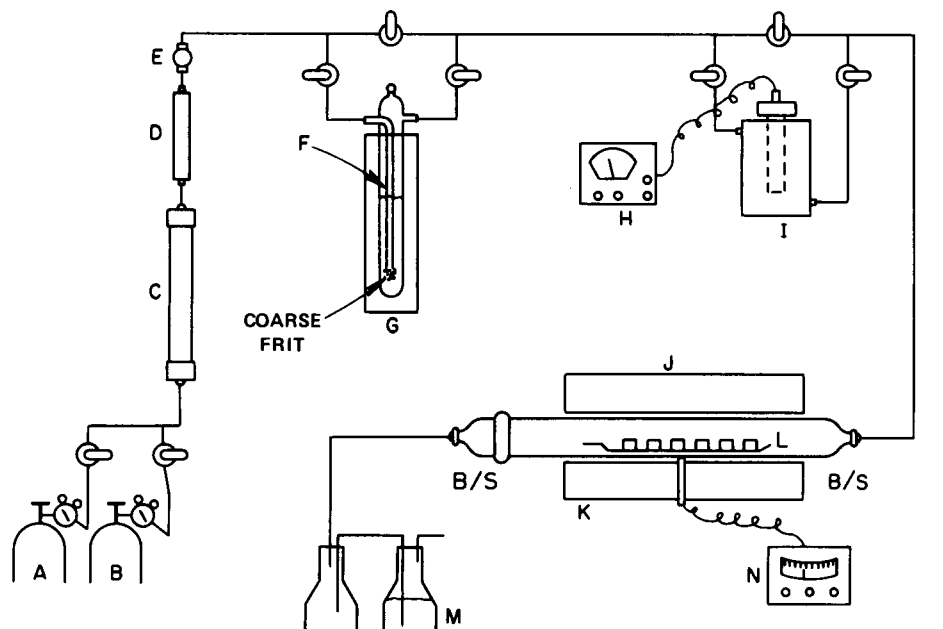

- | | | |
|--------------------------|-----------------------------|---------------------------|
| A. ARGON OR HELIUM | F. WATER BUBBLER | K. FUSED SILICA TUBE |
| B. 6% H ₂ -He | G. DEWAR FLASK | L. FUSED SILICA BOAT |
| C. DRYING TUBE | H. PANAMETRICS CONTROL UNIT | M. BUBBLER |
| D. FLOWMETER | I. PANAMETRICS PROBE | N. TEMPERATURE CONTROLLER |
| E. NEEDLE VALVE | J. FURNACE | Ⓢ BALL VALVE |

FIG. 10 O/M Apparatus



121.1.4 Place a whole pellet or pieces of a pellet having a total weight of 1 g or more in each boat and weigh within ± 0.1 mg (W_1) at room temperature.

121.1.5 Place the boats containing the samples into the furnace tube, replace the furnace tube in the furnace, and heat the samples for a minimum of 6 h under the conditions given in 121.1.1 (300 to 500 mL/min of water-saturated hydrogen-helium with the furnace at 800°C).

121.1.6 Remove the furnace tube from the furnace and allow the samples to cool to room temperature in the hydrogen-helium atmosphere.

121.1.7 Remove the boats from the furnace tube and weigh each within ± 0.1 mg (W_2).

121.1.8 Repeat 121.1.5 through 121.1.7 until each boat weight remains constant within ± 0.2 mg. (Heating for 6 h in 121.1.5 should be sufficient to attain constant weight.)

121.2 Powders:

121.2.1 Adjust the flow rate of dry helium (He) or argon (A) (see Fig. 10) to 300 mL/min, adjust valves so that the gas does not pass through the bubbler, turn on the furnace (J), and adjust its temperature to 800°C.

121.2.2 Heat the boats (L) under the above conditions for 1 h, remove the furnace tube from the furnace, and allow boats to cool in the dry gas atmosphere to room temperature.

121.2.3 Remove the boats from the furnace tube, weigh each within ± 0.1 mg, and repeat 121.2.2 and 121.2.3 until a constant tare weight (W_T) is obtained for each empty boat.

121.2.4 Add approximately 1.5 g of powder sample to each boat, adjust the furnace temperature to 150°C, replace the furnace tube in the furnace, place the boats with samples in the furnace tube, and dry the samples at 150°C for 1 h in the dry argon or helium flowing at 300 mL/min.

121.2.5 Transfer each boat and dried sample to a desiccator and allow the sample to cool to room temperature. Quickly weigh the boat and sample (W_1) within ± 0.1 mg.

121.2.6 Prepare the O/M apparatus as described in 121.1.1. Place the boats and samples into the furnace tube, and heat a

minimum of 6 h under the conditions given in 121.1.1 (300 to 500 mL/min water-saturated, hydrogen-helium gas flow at 800°C).

121.2.7 Adjust the furnace temperature to 150°C and adjust the valves so that the hydrogen-helium gas bypasses the ice bath bubbler.

121.2.8 Keep the samples at 150°C, increase the hydrogen-helium gas flow rate to about 1200 mL/min, and measure the moisture content of the exit gas with the moisture analyzer.

121.2.9 When the moisture content of the gas is reduced below 20 ppm, transfer the boats and samples to a desiccator. Allow them to cool to room temperature and quickly weigh each boat and sample (W_2) within ± 0.1 mg.

121.2.10 Repeat steps 121.2.7 through 121.2.9, if necessary, to obtain constant weights (W_2).

122. Calculation

122.1 Calculate the O/M ratio as follows:

$$O/M = 2.000 - \frac{(W_2 - W_1)F}{(W_2 - W_T)} \quad (25)$$

where:

W_2 = final weight of sample and boat,

W_1 = initial weight of sample and boat,

F = (formula weight of metal oxide)/15.999, and

W_T = tare weight of boat.

123. Precision and Bias

123.1 The standard deviations obtained with mixed oxide pellets are 0.001 to 0.002 in the O/M.

123.2 The bias of the test method cannot be tested reliably because of the lack of suitable reference or calibration materials. The absence of bias depends upon quantitative conversion of the sample to the stoichiometric dioxide. The conditions of analysis were selected on the basis of thermodynamic data to ensure complete conversion to the stoichiometric dioxide, and therefore no measurable bias should exist.

REFERENCES

- (1) American Standards Association Inc., Sectional Committee N6 and American Nuclear Society Standards Committee, *Nuclear Safety Guide*, USAEC Report TID-7016 (Rev. 1); AERDB, Goodyear Atomic Corp., 1961.
- (2) Metz, C. F., "Analytical Chemical Laboratories for the Handling of Plutonium," *Proceedings of the Second United Nations International Conference on the Peaceful Uses of Atomic Energy*, Geneva, 1958, Vol 17, pp. 681-690, United Nations, New York, 1959.
- (3) Wick, O. J., Ed., *Plutonium Handbook*, Gordon and Breach Science Publishers, Vol II, 1967.
- (4) Hakkila, E. A., and Waterbury, G. R., "The Determination of Nitride Nitrogen in Plutonium Metal, Alloys and Compounds," Los Alamos Scientific Laboratory Report LA-3452, 1966.
- (5) Metz, C. F., and Waterbury, G. R., "Sealed Tube Dissolution Method with Applications to Plutonium Containing Materials," Los Alamos Scientific Laboratory Report LA-3554, 1966.
- (6) Frant, M. S., and Ross, J. W., Jr., "Electrode for Sensing Fluoride Ion Activity in Solution," *Science*, KAGTA, Vol 154, 1966, p. 1553.
- (7) Rechnitz, G. A., "Ion-Selective Electrodes," *Chemical Engineering News*, CENEA, Vol 25, June 12, 1967, p. 1946.
- (8) Plucinski, C. E., "Determination of Microgram Quantities of Fluoride in Metal Oxides," BNWL-601, Pacific Northwest Laboratory, Richland, WA, March 1968.
- (9) Greenhalgh, R., and Riley, J. R., "The Determination of Fluoride in Natural Waters, with Particular Reference to Sea-Water," *Analytica Chimica Acta*, Vol 25, 1961, p. 179.
- (10) Rein, J. E., Matlack, G. M., Waterbury, G. R., Phelps, R. T., and Metz, C. F., Eds., "Methods of Chemical Analysis for FBR Uranium-Plutonium Oxide Fuel and Source Materials," USAEC Document LA-4622, AERDB, 1971, pp. 95-99.
- (11) *Methods for Emission Spectrochemical Analysis*, ASTM, Philadelphia, PA, 1971.
- (12) Dhumward, R. K., Joshi, M. V., and Patwardan, A. B., "Spectrographic Method for the Determination of Rare Earths in Plutonium—Use of Trilaurylamine," *Analytica Chimica Acta*, Vol 50, 1970, pp. 237-242.



- (13) Ko, R., "Analytical Chemistry Methods in Support of Driver Fuel Fabrication" USAEC Report WHAN-IR-5, Method 20.9, AERDB, August 1970.
- (14) Ralph J. Jones, Ed., "Selected Measurement Methods for Plutonium and Uranium in the Nuclear Fuel Cycle," TID-7029, 1963.
- (15) Rein, J. E., Zeigler, R. K., and Metz, C. F., "LMFBR/FFTF Fuel Development Analytical Chemistry Program (Phase II)," USAEC Report LA-4407, AERDB, 1970.
- (16) Carter, J. A. (1967). "Analysis of Solution and Radioactive Samples by Spark-Source Mass Spectrometry," USAEC, ORNL-P-3051, AERDB, Oak Ridge, TN.
- (17) Carter, J. A., "Quantitative Spark-Source Mass Spectrometric Techniques for the Simultaneous Determination of the Lanthanide and Actinide Elements in Microgram and Submicrogram Transuranium Samples," Ph.D. Dissertation, University of Tennessee, Knoxville, TN, 1970.
- (18) Carter, J. A., and Sites, J. R., "Analytical Chemistry Division Annual Progress Report," H. P. Raaen, Ed., USAEC Report ORNL-4466, AERDB, Oak Ridge, TN, 1970, pp. 93-94.
- (19) Ahearn, A. J., Ed., *Mass Spectrometric Analysis of Solids*, Elsevier Publishing Co., New York, NY, 1966.
- (20) Franklin, J. C., Griffin, E. B., and Catlett, C. E., "Spark-Source Mass Spectrographic Analysis of Uranium Metal," USAEC Report Y-KG-44, AERDB, Oak Ridge, TN, 1967.
- (21) Johnson, A. J., Kozy, A., Morris, R. N., "Sodium Fluoride as a Spectrographic Carrier for Plutonium Metal Analysis," USAEC Report RFP-143, AERDB, Golden, CO, 1969.
- (22) Nichalls, G. D., and Graham, A. L., "Precision and Accuracy in Trace Element Analysis of Geological Materials, Using Solid Source Spark Mass Spectrography," *Analytical Chemistry*, Vol 39, 1967, p. 584.
- (23) Rein, J. E., Matlack, G. M., Waterbury, G. R., Phelps, R. T., and Metz, C. F., Eds., "Methods of Chemical Analysis of FBR Uranium-Plutonium Oxide Fuel and Source Materials," USAEC Document LA-4622, AERDB, 1971, pp. 127-131.
- (24) Rein, J. E., Matlack, G. M., Waterbury, G. R., Phelps, R. T., and Metz, C. F., "Methods of Chemical Analysis for FBR Uranium-Plutonium Oxide Fuel and Source Materials," USAEC Document LA-4622, AERDB, 1971, p. 101.
- (25) Sandell, E. B., *Colorimetric Determination of Traces of Metals*, Interscience Publishers, Inc., New York, NY, (3rd ed), 1959, pp. 883-899.
- (26) Greenberg, P., "Spectrophotometric Determination of Tungsten in Tantalum, Titanium, and Zirconium Using Dithiol," *Analytical Chemistry*, ANCHA, Vol 29, 1957, p. 896.
- (27) Nelson, G. B., and Waterbury, G. R., "Analytical Chemistry in Nuclear Reactor Technology," Fifth Conference, Gatlinburg, TN, Oak Ridge National Laboratory, USAEC Document TID-7629, AERDB, 1961, p. 62.
- (28) Rein, J. E., Ziegler, R. K., and Metz, C. F., "LMFBR/FFTF Fuel Development Analytical Chemistry Program (Phase II)," USAEC Report LA-4407, AERDB, 1970.
- (29) "Methods for the Accountability of Plutonium Dioxide," General Chemistry Division, Lawrence Livermore Laboratory, Directorate of Regulatory Standards, U. S. Atomic Energy Commission, WASH-1335 (unclassified), December 1974.
- (30) Pietri, C. E., New Brunswick Laboratory, U. S. Atomic Energy Commission, *Proceedings of the Symposium on the Calorimetric Assay of Plutonium*, Oct. 24-25, 1973, 'The Determination of Plutonium Isotopic Composition by Mass Spectrometry and Alpha Spectrometry, and Americium-241 Content by Radiocounting.' " MLM-2177 (unclassified).
- (31) Rodden, C. J., "Selected Measurement Methods for Plutonium and Uranium In the Nuclear Fuel Cycle," (TID-7029, 2nd ed.), 1972, p. 310.
- (32) Garner, E. L., Machlan, L. A., Shields, W. R., NIST Special Publication 260-27, U. S. Government Printing Office, Washington, DC 20402, 1971, 150 pp.
- (33) Shields, W. R., NIST Technical Note 277, U. S. Government Printing Office, Washington, DC 20402, 1966, 99 pp.
- (34) Rodden, C. J., "Selected Measurements Methods for Plutonium and Uranium in the Nuclear Fuel Cycle" USAEC Document TID-7029, 2nd ed, 1972, p. 124.
- (35) Marsh, S. F., Ortiz, M. R., Abernathy, R. M., and Rein, J. E., "Improved Two-Column Ion Exchange Separation of Plutonium, Uranium, and Neodymium in Mixed Uranium-Plutonium Fuels for Burnup Measurement," USAEC Document LA556B, June 1974.
- (36) McNeilly, C. E., and Chikalla, T. D., "Determination of Oxygen/Metal Ratios for Uranium, Plutonium, and (U,Pu) Mixed Oxides," National Ceramic Society Meeting, Washington, DC, May 2-8, 1969.
- (37) *The Matheson Gas Data Book*, 4th Edition, The Matheson Co., 1966.
- (38) Rein, J. E., Matlack, G. M., Waterbury, G. R., Phelps, R. T., and Metz, C. F., Eds., "Methods of Chemical Analysis for FBR Uranium-Plutonium Oxide Fuel and Source Materials," USAEC Document LA-4622, AERDB, 1971, pp. 147-155.
- (39) Urie, M. W., Burt, M. C. and Delvin, W. L., "A Comparison of Thermogravimetric Methods Used to Determine Oxygen-to-Metal Ratios in Mixed-Oxide Fuels," Hanford Engineering Development Laboratory Report HEDL-TME-72-56, April 1972.

The American Society for Testing and Materials takes no position respecting the validity of any patent rights asserted in connection with any item mentioned in this standard. Users of this standard are expressly advised that determination of the validity of any such patent rights, and the risk of infringement of such rights, are entirely their own responsibility.

This standard is subject to revision at any time by the responsible technical committee and must be reviewed every five years and if not revised, either reapproved or withdrawn. Your comments are invited either for revision of this standard or for additional standards and should be addressed to ASTM Headquarters. Your comments will receive careful consideration at a meeting of the responsible technical committee, which you may attend. If you feel that your comments have not received a fair hearing you should make your views known to the ASTM Committee on Standards, at the address shown below.

This standard is copyrighted by ASTM, 100 Barr Harbor Drive, PO Box C700, West Conshohocken, PA 19428-2959, United States. Individual reprints (single or multiple copies) of this standard may be obtained by contacting ASTM at the above address or at 610-832-9585 (phone), 610-832-9555 (fax), or service@astm.org (e-mail); or through the ASTM website (www.astm.org).