



Designation: E 1008 – 9703

Standard Practice for Installation, Inspection, and Maintenance of Valve B-body Pressure R-relief Methods for Geothermal and Other High- Temperature Liquid Applications¹

This standard is issued under the fixed designation E 1008; the number immediately following the designation indicates the year of original adoption or, in the case of revision, the year of last revision. A number in parentheses indicates the year of last reapproval. A superscript epsilon (ϵ) indicates an editorial change since the last revision or reapproval.

1. Scope

1.1 This practice covers installation, inspection, and maintenance of valve body cavity pressure relief methods for valves used in geothermal and other high-temperature liquid service. The valve type covered by this practice is a design with an isolated body cavity such that when the valve is in either the open or closed position pressure is trapped in the isolated cavity, and there is no provision to relieve the excess pressure internally.

1.2 *This standard does not purport to address all of the safety concerns, if any, associated with its use. It is the responsibility of the user of this standard to establish appropriate safety and health practices and determine the applicability of regulatory limitations prior to use.*

2. Referenced Documents

2.1 *API Standard:*

¹ This practice is under the jurisdiction of ASTM Committee E44 on Solar, Geothermal, and Other Alternative Energy Sources and is the direct responsibility of Subcommittee E44.15 on Field Development.

Current edition approved Oct. 10 1997; 1, 2003. Published May 1998.

Originally published as E 1008-84. October 2003. Originally approved in 1984. Last previous edition E 1008-84 (1991) approved in 1997 as E 1008-97.

6D—Specifications for Pipe Line Valves, End Closures, Connectors and Swivels²

2.2

Proposed specification ISO/DIS 14313

3. Definitions

3.1 *relief device*— a spring loaded valve or rupture disk that will relieve excessive pressure from the body cavity at a predetermined ~~pressure level.~~ pressure.

4. Installation

4.1 Any valve conforming to the description in 1 of this practice shall have a body cavity pressure relief device installed in a manner to relieve excessive pressure from the body cavity. The relief pressure setting shall not exceed ~~100 psi~~ 700 kPa (101.5 psi) above the rated working pressure of the valve assembly at 40 °C (100° F) as defined in the latest edition of API 6D.

4.2 The installation shall be such that direct access to the body cavity is maintained and that the pressure relief device may be periodically removed, cleaned, inspected, and reinstalled without endangering the operating personnel or removing the valve from its functional application.

4.2.1 The relief device may be mounted with an automatic shutoff, such as a check valve held in the open position by the relief device. An example of such an assembly is shown in Fig. 1. The shutoff device will not be rendered inoperative.

5. Cold-Weather Considerations

5.1 ~~Temperatures below freezing temperatures~~ are considered due to ice formation within the body cavity and the associated expansion.

5.2 The recommended procedures for winterizing (for example, for temperatures below freezing temperatures) freezing valves of the type described in 1 of this recommended practice shall be as follows:

5.2.1 The valve must be fully closed or fully opened.

5.2.2 The body cavity should be purged with a nonreactive gas (for example, nitrogen) or filled with a fluid to produce a solution with a low freezing point (below -45° C (-49° F)).

6. Inspection

6.1 The pressure relief device shall be kept clean to ensure proper operation.

6.2 The relief device shall be removed, inspected, then cleaned, repaired, or replaced, and reinstalled on a schedule determined by the respective application. The recommended inspection period shall not exceed one year.

6.3 If removal of the relief device shall seal the valve body cavity, (for example, a spring loaded check valve as shown in Fig. 1) and the working temperature of the valve may change, then a substitute relief device shall be installed immediately.

6.4 The opening to the valve body cavity shall be inspected for blockage, and any blockage of scale or any other foreign material.

6.5 The pressure relief device shall be reinstalled in accordance with ~~of~~ this practice.

7. Keywords

7.1 geothermal valve; pressure-relief device

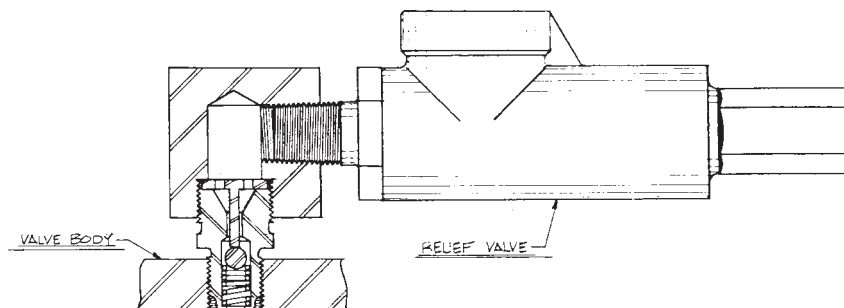

FIG. 1 Assembled Valve-B_{body} Pressure-R_{elieving}f Device

² Available from American Petroleum Institute, 2101 L St., N.W., Washington, DC 20037.

ASTM International takes no position respecting the validity of any patent rights asserted in connection with any item mentioned in this standard. Users of this standard are expressly advised that determination of the validity of any such patent rights, and the risk of infringement of such rights, are entirely their own responsibility.

This standard is subject to revision at any time by the responsible technical committee and must be reviewed every five years and if not revised, either reapproved or withdrawn. Your comments are invited either for revision of this standard or for additional standards and should be addressed to ASTM International Headquarters. Your comments will receive careful consideration at a meeting of the responsible technical committee, which you may attend. If you feel that your comments have not received a fair hearing you should make your views known to the ASTM Committee on Standards, at the address shown below.

This standard is copyrighted by ASTM International, 100 Barr Harbor Drive, PO Box C700, West Conshohocken, PA 19428-2959, United States. Individual reprints (single or multiple copies) of this standard may be obtained by contacting ASTM at the above address or at 610-832-9585 (phone), 610-832-9555 (fax), or service@astm.org (e-mail); or through the ASTM website (www.astm.org).