



Designation: E 1084 – 86 (Reapproved 1996)

Standard Test Method for Solar Transmittance (Terrestrial) of Sheet Materials Using Sunlight¹

This standard is issued under the fixed designation E 1084; the number immediately following the designation indicates the year of original adoption or, in the case of revision, the year of last revision. A number in parentheses indicates the year of last reapproval. A superscript epsilon (ϵ) indicates an editorial change since the last revision or reapproval.

1. Scope

1.1 This test method covers the measurement of solar transmittance (terrestrial) of materials in sheet form by using a pyranometer, an enclosure, and the sun as the energy source.

1.2 This test method also allows measurement of solar transmittance at angles other than normal incidence.

1.3 This test method is applicable to sheet materials that are transparent, translucent, textured, or patterned.

1.4 *This standard does not purport to address all of the safety concerns, if any, associated with its use. It is the responsibility of the user of this standard to establish appropriate safety and health practices and determine the applicability of regulatory limitations prior to use.*

2. Referenced Documents

2.1 *ASTM Standards:*

E 284 Terminology of Appearance²

E 772 Terminology Relating to Solar Energy Conversion³

2.2 *Other Document:*

ASHRAE Handbook of Fundamentals⁴

3. Terminology

3.1 *Definitions:*

3.1.1 *pyranometer, n*—a radiometer used to measure the total solar radiant energy incident upon a surface per unit time per unit area. This energy includes the direct radiant energy, diffuse radiant energy, and reflected radiant energy from the background.

3.1.2 *solar reflectance, n*—the ratio of reflected to incident solar flux.

3.1.3 *solar transmittance, n*—the ratio of transmitted to incident solar flux.

3.2 *Definitions of Terms Specific to This Standard:*

3.2.1 *solar flux, n*—the total radiation from the sun, both direct and diffuse.

4. Summary of Test Method

4.1 Using a pyranometer to measure the solar irradiance, the test specimen is inserted in the path of the rays from the sun to the pyranometer. An enclosure with a nonreflecting bottom is used to avoid measuring flux from around the edges of the specimen or from multiple reflections between the box and the specimen. The transmittance is the ratio of the flux measured with the specimen in the light path to the flux measured without the specimen in the path.

5. Significance and Use

5.1 Solar transmittance is an important factor in the admission of energy through fenestration, collector glazing, and protective envelopes. This test method provides a means of measuring this factor under fixed conditions. While the data may be of assistance to designers in the selection and specification of glazing materials, the solar transmittance is not sufficient to define the rate of net heat transfer without information on other important factors.

5.2 This test method has been found practical for both transparent and translucent materials, as well as for those with transmittance reduced by highly reflective coatings. This test method is particularly applicable to the measurement of transmittance of inhomogeneous, fiber reinforced, patterned, or corrugated materials since the transmittance is averaged over a large area.

5.3 This test method may be used to measure transmittance of glazing materials at angles up to 60° off normal incidence.

NOTE 1—A technique similar to the one described but using a pyrhe-liometer has been used for the measurement of specular solar reflectance; however, there is insufficient experience with this technique for standardization at present.

6. Apparatus

6.1 *Enclosure*—The required apparatus is a box capable of supporting a 0.60 m (24 in.) square specimen. The box shall have a square, clear aperture of no less than 0.50 m by 0.50 m (20 in. by 20 in.). The enclosure shall have provisions to hold specimens planar across the aperture with the additional capability to remove and replace the specimen easily during the measurement process. It shall also have the capability to move the specimen across the aperture in a systematic way. Light baffled air vents at the top and bottom of the enclosure are

¹ These test methods are under the jurisdiction of ASTM Committee E44 on Solar, Geothermal, and Other Alternative Energy Sources and is the direct responsibility of Subcommittee E44.05 on Solar Heating and Cooling Subsystems and Systems.

Current edition approved Feb. 21, 1986. Published April 1986.

² *Annual Book of ASTM Standards*, Vol 06.01.

³ *Annual Book of ASTM Standards*, Vol 12.02.

⁴ Available from American Society of Heating, Refrigerating, and Air Conditioning Engineers, 1791 Tullie Circle N.E., Atlanta, GA 30329.

ASTM E 1084

recommended to aid cooling of all components when a specimen is in place. The inside of the box shall have side walls covered with mirrors having specular, solar reflectance greater than 0.85 that extend from the opening down to the plane of the sensor element. Therest of the inside of the box shall be blackened so that its solar reflectance is less than 0.10. A typical unit is shown in Fig. 1.

NOTE 2—Mirrors having the necessary specular reflectance are bright anodized aluminum lighting sheet, aluminized polymer films, and con-

ventionally mirrored glass. For highly diffusing materials, a box with the specified aperture and blackened side walls, the test method could underestimate the transmittance by up to 0.03. Using highly reflecting side walls on the interior of the enclosure reduces this error for such materials to less than 0.01 transmittance unit. For highly specular materials, this error is negligible.

NOTE 3—For an enclosure with a highly reflecting bottom, the measured transmittance could be greater than 0.05 too high due to multiple reflections. A blackened bottom having less than 0.10 reflectance will hold

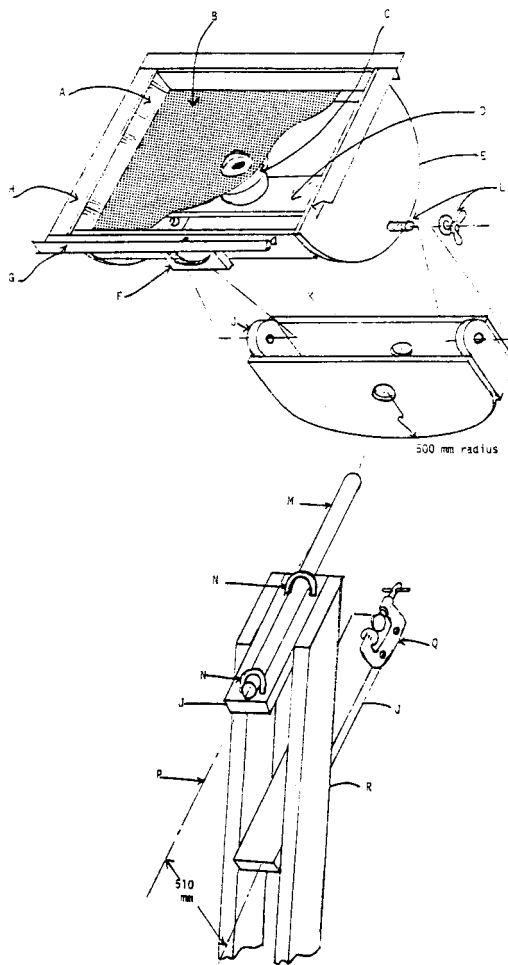

- (A) Specular mirror, 500 × 50 mm.
- (B) Nonreflecting, black bottom. Nontransmitting louvers or multiple layers of grill cloth that allow air circulation into the enclosure are preferable.
- (C) Pyranometer
- (D) Support shelf for pyranometer. The height of the shelf will depend on the pyranometer used.
- (E) Semicircular disk 538 mm diameter out of 3/4 in plywood.
- (F) Semicircular tracker with scale
- (G) Lip of flange turned up to 20 mm to help support specimens
- (H) 50 mm flange bent out of sheet metal or cut from wood. Top surface is painted back to prevent light entering enclosure due to multiple reflections from around the specimen edges.
- (J) Standard 2 × 4 in. wood framing, 75 mm long (bottom to center of hole)
- (K) Rectangular, 3/4 in. plywood, 500 × 75 mm.
- (L) 1/2 × 2 in. carriage bolt with wing and washer.
- (M) 3/4 in. iron pipe.
- (N) U-bolts.
- (P) Primary tracking axis, aligned parallel to earth's axis of rotation. The axis shall make an angle with the vertical equal to the local latitude and point toward the North Star.
- (Q) C-clamp attached to arm to lock equatorial angle during measurements.
- (R) Vertical support post approximately 1 m long. Made from standard 2 × 6 ft lumber.

NOTE 1—This apparatus consisting of enclosure, detector, and equatorial mount has been found acceptable for measuring solar transmittance of sheet materials. The majority of the pieces are cut from standard 2.4, 2 by 6, and 3/4 in. plywood construction materials.

FIG. 1 Apparatus Consisting of Enclosure, Detector, and Equatorial Mount

this error to less than 0.005 transmittance units.⁵

6.2 Tracking:

6.2.1 The enclosure shall be mounted in a manner that allows repositioning approximately every 15 min in order to track the sun. The use of an equatorial or altazimuth mount is recommended and automatic solar tracker is optional.

6.2.2 For manual tracking, an alignment device shall be used. Several acceptable devices are shown in Fig. 2.

6.3 Sensor:

6.3.1 The sensing element of this apparatus is a pyranometer that shall meet WMO Class 2 specifications (1, 2).⁶ The most important characteristics for the pyranometer are as follows:

6.3.1.1 a flat spectral sensitivity ($\pm 2\%$) over the region from 300 nm to 3000 nm that encompasses nearly all the terrestrial solar flux;

⁵ Flat black paints that are satisfactory for this purpose are 3M brand ECP-2200 available from 3M Company; Parson's Black available from Eppley Laboratories, Newport, RI; or Krylon Flat Black. Other flat black paints may also be satisfactory. Also, a lining of opaque black velvet cloth such as available from photographic suppliers is suitable.

⁶ The boldface numbers in parentheses refer to the list of references at the end of this standard.

6.3.1.2 sensitivity that is isotropic except for the usual cosine response with altitude angle; and

6.3.1.3 output linear to within $\pm 2\%$ from 0 to 1000 W/m² or calibration curves accurate to within $\pm 2\%$ over the same range. Additional desirable characteristics are relative short-time constants of a few seconds and good temperature stability.

NOTE 4—When using pyranometers meeting WMO Class 2 specifications in this procedure, the inaccuracies due to these sources are expected to be less than 1%. This is because relative, rather than absolute, readings are made over a dynamic range that is small compared to the range of the sensor. The procedure and apparatus specified in this test method minimize the thermal drift during the measurements.

6.3.2 The pyranometer shall be located so that the sensing thermopile (not the dome) is centered approximately 50 mm (2 in.) below the plane of the rim of the box. Normally pyranometers have a 180° viewing angle, but when placed as described, the field angle to the midpoint of the edges of the test specimen is 157°.

6.3.3 For pyranometers with thermal control shields having high reflectance, for example, the Eppley P.S.P.) it is important that the reflection from the pyranometer back toward the sheet material under test be minimized. This can be done by covering

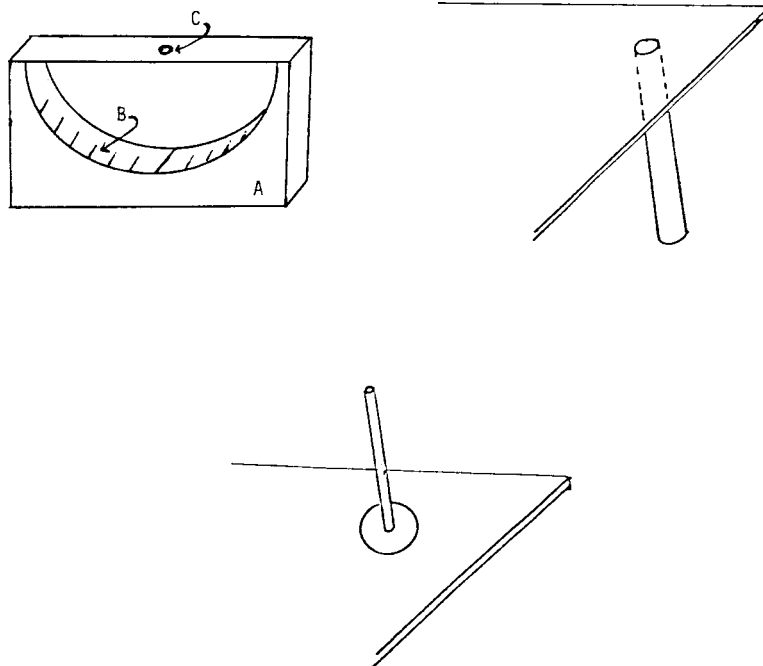

(a) Semicircle with scale
 (A) Semicircle with 143 mm radius cut out of 150 300 mm piece of 1/2 to 3/4 in. plywood.
 (B) Tape with 1 cm scale attached to inside of semicircle.
 (C) This opaque sheet (preferably metal) with 3 mm aperture centered above semicircle.

(b) 12.7 mm (1/2 in.) ID pipe by 195 mm (7.67 in.) long. Note—Realign when direct from the solar disk no longer traverses the pipe.

Note—A displacement of the light beam coming through the aperture of 1 cm on the circumference of the semicircle equals 4° misalignment. This tracker is convenient for determining angles for off normal incidence measurements.

(c) 9 mm diameter rod by 500 mm long centered on 80 mm diameter white disk.
 Note—Realign when shadow of rod falls outside of white disk.

NOTE 1—The dimensions are chosen to provide $\pm 4^\circ$ limits on deviations from normal to the sun. In (b) and (c) care must be taken to mount the rod or pipe perpendicular to the surface of the enclosure.

FIG. 2 Alignment Devices for Enclosure



the shield with a nonreflecting material or by mounting the pyranometer outside the enclosure with only the dome and sensor element projecting into the box.

NOTE 5—Mounting the pyranometer outside of the enclosure also reduces the heating load and cooling requirements for the pyranometer.

7. Specimens

7.1 The test specimens shall not be less than 0.60 by 0.60 m (24 by 24 in.). Care must be taken to prevent light leaks at the edges, especially if the cross-sectional shape of the specimen is not flat. Also, if the cross-sectional shape is not flat or if the specimen is patterned, a specimen enough larger to allow translation across the pyranometer by at least one period of the shape or pattern is required.

8. Procedure

8.1 Conduct the tests on a sunny day with no cloud cover within $\pm 15^\circ$ of the sun and a minimum normal solar irradiance of 700 W/m² and constant to within 1 % during the individual tests. Conduct testing as close to solar noon as possible but no more than 3 h before or after solar noon.

8.2 Set up apparatus at a location where no prominent structure or vegetation is nearby in the pyranometer's field of view.

8.3 Align the box aperture to within 4° of the normal to the sun's rays, and measure the solar flux with no specimen in place. Allow adequate time for the trace or reading to stabilize.

8.4 Place the test specimen on the box and measure the transmitted solar flux, again allowing adequate time for the trace or reading to stabilize.

NOTE 6—Operate the pyranometer as directed by its manufacture except that horizontal mounting requirements must be ignored. Long response times are undesirable because of the potential measurement error due to changing irradiance and the inconvenience of slow sample throughput. The manufacturer shall be consulted if response times other than original provided are desired.

8.5 Compute the solar transmittance of the test specimen as the ratio of the flux measured when the test specimen is placed between the sun and the sensor to the flux measured by the sensor with no test specimen in place.

NOTE 7—For a sensor with linear response, the ratio is equal to the ratio of the output signals with and without the specimen in place.

8.6 Repeat the steps in 8.3 and 8.4 a minimum of five times or until the estimated standard deviation of the average value for the calculated transmittance is acceptable. Make each measurement with the specimen in a different location.

8.7 Compute the estimated standard deviation of the average transmittance of the specimen using the following equation:

$$S_r = \sqrt{\frac{\sum_{j=1}^n (\bar{\tau} - \tau_j)^2}{(n)(n-1)}} \quad (1)$$

where:

S_r = the estimated standard deviation of the average,

$\bar{\tau}$ = the average transmittance,

j = the j th individual measurement of the transmittance, and

n = the number of individual measurements made.

8.8 Align the apparatus, at least every 15 min.

8.9 When measuring corrugated or nonuniformly transmitting specimens, translate the specimen in such a way as to obtain an average value for the transmittance. Since a systematic translation over one period of structure is required, it is permissible to perform the step in 8.3. Then take several measurements with sample on the box (8.4) before repeating the step in 8.3, provided these before and after readings are in close agreement.

NOTE 8—Do not leave the specimens on the box for periods longer than 10 min since it may cause overheating of the sensor, resulting in nonlinear response or even permanent damage.

8.10 Measurement of the solar transmittance of sheet materials at angles up to 60° off normal incidence is also permitted by this test method. To do this, align the box aperture with respect to the solar angle to provide the desired incidence angle, and follow the steps in 8.4 to 8.7.

9. Report

9.1 The report shall include the following information:

9.1.1 The source and identity of the test specimen,

9.1.2 A complete description of the test specimen, that is, thickness, cross-sectional shape, color, size, translucent or transparent, type of material.

9.1.3 The orientation of the sample based on any nonuniformity or anisotropy such as surface coatings, exposed surface fiber orientation, color bands, etc. during each measurement.

9.1.4 For each angle of incidence used, report the following information.

9.1.4.1 The angle of incidence.

9.1.4.2 The solar transmittance as the average of the five or more measurements to the nearest 0.01 transmittance unit.

9.1.4.3 The estimated standard deviation of the average calculated as in 8.7.

9.1.4.4 The number of measurements used in the computation.

9.1.5 The place, date, and time of the test.

9.1.6 The solar irradiance as measured in 8.3.

9.1.7 Type, model, serial number, and current calibration curves of sensing unit used,

9.1.8 Ambient air temperature, relative humidity, and atmospheric visibility.

10. Precision and Bias

10.1 *Precision:* The within laboratory precision in the measurement depends on the nature of the specimen and is defined as the estimated standard deviation in the average transmittance. The imprecision decreases as the number of measurements increases in a complex way that is approximately proportional to $(n)^{-1/2}$. Data from one series of tests using this test method is reproduced in Appendix X1. The estimated standard deviation obtained from eight measurements varies from ± 0.002 transmittance units for a transparent acrylic sheet to ± 0.025 transmittance units for a highly embossed diffuser for lighting fixtures.



10.1.1 The between laboratory precision is affected by the differences in the terrestrial irradiance distributions at various sites. These arise from differences in altitude, latitude, and atmospheric water vapor and aerosol levels. Differences of up to 0.04 transmittance units can be expected for some materials such as polymers that have considerable spectral dependence (3). Evidence for even larger variance in transmittance of weathered (yellowed) polymers exists. Thus, transmittance values obtained at an arid, high altitude site while using this test method may vary a few percent from the transmittance measured at a marine location. Obviously, each measured value is correct only for the particular measurement environment, and caution should be used in applying the results to other environments.

10.2 *Bias:*

10.2.1 No rigorous bias statement can be made because of a lack of standard reference materials and the variations in the terrestrial solar spectral irradiance.

10.2.2 For measurements made at normal incidence in a particular location and weather conditions, the bias of the results is expected to be better than 0.02 transmittance units for those particular conditions. This is based on the root mean square of the estimated uncertainties due to the various components of the apparatus described in Section 6.

10.2.3 The bias of the measurement decreases with increasing angle of incidence. For transparent materials, the transmittance measured at 60° incidence is shown in Table X1.2 to be within ±0.005 of the value calculated using Fresnel coefficients (4) and the data from measurements at normal incidences. For translucent materials, the errors for off normal incidence measurements could be as much as twice as large as those for transparent materials.

11. Keywords

11.1 sheet materials; solar transmittance; transmittance

APPENDIX

(Nonmandatory Information)

X1. Table X1.1 and Table X1.2

TABLE X1.1 Data for Solar Transmittance of Three Different Sheet Materials Obtained Using Test Method E 1084

Measure- ment Number	Solar Transmittance		
	Float Glass 6 mm thick	Translucent Shower Curtain	Prismatic Textured Diffuser
1	0.864	0.865	0.804
2	0.869	0.870	0.786
3	0.870	0.891	0.957
4	0.864	0.883	0.917
5	0.859	0.867	0.974
6	0.862	0.873	0.799
7			0.740
8			0.905
average	0.865	0.875	0.86
S_r^A	0.002	0.004	0.03

^A S_r = estimated deviation of average.

TABLE X1.2 Comparison of Angular Dependence of Transmittance Measured by Test Method E 1084 to that Calculated Using Fresnel Formulas (3)

Material	Index of Refrac- tion	Normal Incidence Absorptance	Transmittance				
			0°	15°	30°	45°	60°
Flat Glass	1.52	0.060					
			Measured	0.865 ± 0.002	0.865 ± 0.001	0.856 ± 0.001	0.840 ± 0.002
Calculated			0.865	0.864	0.859	0.843	0.783
Transparent Plexiglas	1.48	0.021					
			Measured	0.908 ± 0.002	0.909 ± 0.002	0.900 ± 0.003	0.893 ± 0.003
Calculated			0.908	0.908	0.905	0.890	0.830



REFERENCES

- (1) *Guide to Meteorological Instrument and Observing Practices*, 2nd ed., Chapter 9, World Meteorological Organization (WMO), 41 Ave. Giuseppe-Motta, Geneva, Switzerland.
- (2) Kinsell, Carson L., *Solar and Terrestrial Radiation*, Academic Press, New York, London, 1975, p. 100.
- (3) Lind, M. A.; Pettit, R. B.; Masterson, K. D., "The Sensitivity of Solar Transmittance, Reflectance, and Absorptance to Selected Averaging Procedures and Solar Irradiance Distributions," *Journal of Solar Energy Engineering*, ASME, February 1980.
- (4) *Handbook of Optics*. Walter G. Driscoll, ed., McGraw-Hill, New York, NY, 1978, pp. 10-6 to 10-12.

ASTM International takes no position respecting the validity of any patent rights asserted in connection with any item mentioned in this standard. Users of this standard are expressly advised that determination of the validity of any such patent rights, and the risk of infringement of such rights, are entirely their own responsibility.

This standard is subject to revision at any time by the responsible technical committee and must be reviewed every five years and if not revised, either reapproved or withdrawn. Your comments are invited either for revision of this standard or for additional standards and should be addressed to ASTM International Headquarters. Your comments will receive careful consideration at a meeting of the responsible technical committee, which you may attend. If you feel that your comments have not received a fair hearing you should make your views known to the ASTM Committee on Standards, at the address shown below.

This standard is copyrighted by ASTM International, 100 Barr Harbor Drive, PO Box C700, West Conshohocken, PA 19428-2959, United States. Individual reprints (single or multiple copies) of this standard may be obtained by contacting ASTM at the above address or at 610-832-9585 (phone), 610-832-9555 (fax), or service@astm.org (e-mail); or through the ASTM website (www.astm.org).