



# Standard Guide for Selection and Use of Portable Radiological Survey Instruments for Performing In Situ Radiological Assessments in Support of Decommissioning<sup>1</sup>

This standard is issued under the fixed designation E 1893; the number immediately following the designation indicates the year of original adoption or, in the case of revision, the year of last revision. A number in parentheses indicates the year of last reapproval. A superscript epsilon ( $\epsilon$ ) indicates an editorial change since the last revision or reapproval.

## 1. Scope

1.1 This standard provides recommendations on the selection and use of portable instrumentation that is responsive to levels of radiation that are close to natural background. These instruments are employed to detect the presence of residual radioactivity that is at, or below, the criteria for release from further regulatory control of a component to be salvaged or reused, or a surface remaining at the conclusion of decontamination and/or decommissioning.

1.2 The choice of these instruments, their operating characteristics and the protocols by which they are calibrated and used will provide adequate assurance that the measurements of the residual radioactivity meet the requirements established for release from further regulatory control.

1.3 This standard is applicable to the in situ measurement of radioactive emissions that include:

1.3.1 alpha

1.3.2 beta (electrons)

1.3.3 gamma

1.3.4 characteristic x-rays

1.3.5 The measurement of neutron emissions is not included as part of this standard.

1.4 This standard does not address instrumentation used to assess residual radioactivity levels contained in air samples, surface contamination smears, bulk material removals, or half/whole body personnel monitors.

1.5 This standard does not address records retention requirements for calibration, maintenance, etc. as these topics are considered in several of the referenced documents.

## 2. Referenced Documents

### 2.1 ASTM Standards:

E 170 Standard Terminology Relating to Radiation Measurements and Dosimetry<sup>2</sup>

E 181 Standard General Methods for Detector Calibration

and Analysis of Radionuclides<sup>2</sup>

C 1215 Standard Guide for Preparing and Interpreting Precision and Bias Statements in Test Method Standards Used in the Nuclear Industry<sup>3</sup>

### 2.2 ANSI Standards:

ANSI N323 Radiation Protection Instrumentation Test and Calibration<sup>4</sup>

ANSI N15.5 Statistical Terminology and Notation for Nuclear Materials Management<sup>4</sup>

ANSI N42.17A Performance Specifications for Health Physics Instrumentation-Portable Instrumentation for Use in Normal Environmental Conditions<sup>4</sup>

ANSI N42.17C Performance Specifications for Health Physics Instrumentation-Portable Instrumentation for Use in Extreme Environmental Conditions<sup>4</sup>

ANSI N42.3 Standard Test Procedure for Geiger Mueller Counters<sup>4</sup>

### 2.3 National Council on Radiation Protection and Measurements:

NCRP Report No. 57 Instrumentation and Monitoring Methods for Radiation Protection, National Council on Radiation Protection and Measurements, May 1978<sup>5</sup>

NCRP Report No. 58 A Handbook of Radioactivity Measurement Procedures, National Council on Radiation Protection and Measurements, 2nd Ed. February 1985<sup>5</sup>

NCRP Report No. 112 Calibration of Survey Instruments Used in Radiation Protection for the Assessment of Ionizing Radiation Fields and Radioactive Surface Contamination, National Council on Radiation Protection and Measurements, December 1991<sup>5</sup>

2.4 International Organization for Standardization (ISO): ISO-4037 X and Gamma Reference Radiations for Calibrating Dosimeters and Dose-rate Meters and for Determining their Response as a Function of Photon Energy, International Organization for Standardization, 1979<sup>6</sup>

<sup>1</sup> This guide is under the jurisdiction of ASTM Committee E10 on Nuclear Technology and Applications and is the direct responsibility of Subcommittee E10.03 on Radiological Protection for Decontamination and Decommissioning of Nuclear Facilities and Components.

Current edition approved June 10, 1997. Published March 1998.

<sup>2</sup> Annual Book of ASTM Standards, Vol 12.02.

<sup>3</sup> Annual Book of ASTM Standards, Vol 12.01.

<sup>4</sup> American National Standards Institute, 11 W. 42nd St., 13<sup>th</sup> Floor, New York, NY 10036

<sup>5</sup> National Council on Radiation Protection and Measurement, 7910 Wodmont Ave., Bethesda, MD 20814

<sup>6</sup> Available from ANSI Sales Department, 1430 Broadway, New York, NY 10018

ISO-6980 Reference Beta Radiations for Calibrating Dosimeters and Dose-rate Meters and for Determining Their Response as a Function of Beta Radiation Energy, International Organization for Standardization, 1984<sup>6</sup>

ISO-8769 Reference Sources for the Calibration of Surface Contamination Monitors – Beta Emitters (Maximum Beta Energy Greater than 0.15 MeV) and Alpha Emitters, International Organization for Standardization, 1988<sup>6</sup>

ISO-7503–1 Evaluation of Surface Contamination - Part 1: Beta Emitters (Maximum Beta Energy Greater than 0.15 MeV) and Alpha Emitters, International Organization for Standardization, 1988<sup>6</sup>

ISO-7503–2 Evaluation of Surface Contamination - Part 2: Tritium Surface Contamination, International Organization for Standardization, 1988<sup>6</sup>

ISO-7503–3 Evaluation of Surface Contamination - Part 3: Isomeric Transition and Electron Capture Emitters, Low Energy Beta Emitters ( $E_{\beta_{\max}} < 0.15$  MeV), International Organization for Standardization, 1993 (draft)

2.5 *Department of Energy (DOE):*

G-10CFR835/E1-Rev. 1 “Instrument Calibration for Portable Survey Instruments,” Implementation Guide for Use with Title 10, Code of Federal Regulations, Part 835, November 1994.

### 3. Terminology

3.1 *Definitions:*

3.1.1 *Calibration, v*—adjusting or determining the response or reading of an instrument relative to a series of conventionally true values for radiation sources (ANSI N323).

3.1.2 *Certified reference material, n*—a material that has been characterized by a recognized standard or testing laboratory for some of its chemical or physical or radiological properties, and that is generally used for calibration of a measurement system or for development or evaluation of a measurement method (ASTM E170).

3.1.3 *Calibration source, n*—as used in this standard guide, see certified reference material.

3.1.4 *Check source, n*—a radioactive source, not necessarily calibrated, which is used to confirm the continuing satisfactory operation of an instrument (ANSI N323).

3.1.5 *Functional check, n*—checks (often qualitative) to determine that an instrument is operational and capable of performing its intended function (ANSI N323).

DISCUSSION—such checks may include, for example, battery check, high voltage check/adjustment, zero setting, audio settings, alarm settings, scale checks and check source and background response.

3.1.6 *Traceability, n*—the ability to demonstrate that a particular measurement instrument or artifact standard has been calibrated at acceptable time intervals against a national or international standard, or against a secondary standard which has been, in turn, calibrated against a national standard or transfer standard (ASTM E170).

3.1.7 *National standard, n*—an artifact, such as a well-characterized instrument or radiation source, that embodies the international definition of primary physical measurement standard for national use (ASTM E170); see also certified reference material.

3.1.8 *Transfer standard, n*—a physical measurement standard that is calibrated by direct or indirect comparison to a national standard and is typically a measurement instrument or radiation source (ASTM E170).

3.1.9 *Accuracy, n*—the degree of agreement of an individual measurement or average of measurements with an accepted reference value or level (ASTM E170).

3.1.10 *Precision, n*—the degree of mutual agreement among individual measurements (ASTM E170).

DISCUSSION—Relative to a test method, precision is the degree of mutual agreement among individual measurements made under prescribed like conditions. The imprecision of a measurement may be characterized as the standard deviation of errors of measurement.

3.1.11 *Lower limit of detection, n*—the smallest amount of a measured quantity that will produce a net signal above the system noise for a given measurement system or process that will result in an acceptable false positive rate if nothing is present and that will be correctly interpreted as “real” with a desired probability.

DISCUSSION—the usual acceptable error rates for in situ measurements are a false positive rate of 5% (Type I error) and a false negative rate of 5% (Type II error).

3.1.12 *Hot Spot, n*—localized areas of elevated activity that are less than 100 cm<sup>2</sup> in extent and exceed the applicable average guideline value by greater than a factor of three.

3.1.13 *Minimum detectable activity (MDA), n*—see lower limit of detection (for purposes of this standard, MDA will be applied to the measurement of a point source or “hot spot” detection).

3.1.14 *Minimum surface sensitivity (MSS), n*—see lower limit of detection (for purposes of this standard, MSS will be applied to measurements of distributed activity, which will incorporate the detector area to enable direct comparison to regulatory guidelines for surface activity).

3.1.15 *Scan, n*—the process whereby the surveyor moves the probe over the area being surveyed in an attempt to locate areas with residual radioactivity.

DISCUSSION—the techniques of the scanning process will have significant affect on the MSS. Important parameters include scan speed, detector orientation, source-detector distance, scanned surface condition and the background response of the instrument.

3.1.16 *Scaler, n*—a digital electronic characteristic of a meter which counts the distinct number of input pulses within a preset period of time.

3.1.17 *Ratemeter, n*—an analog or digital electronic characteristic of a meter which provides the number of pulses per unit time.

3.1.18 *Unrestricted release, n*—the release of a material or a surface area for use without further radiological controls.

DISCUSSION—This occurs after the material or area has been surveyed and the results of the survey show that residual radioactivity is below project specific release criteria. All instrumentation and techniques used for this application must be capable of detecting radioactivity at levels below the release criteria.

3.1.19 *Control charts, n*—A plot of the results of a quality control action to record and demonstrate that control is being maintained within expected statistical variation or to indicate when control is or will be lost without intervention (DOE-G-10CFR835/E1).

DISCUSSION—This provides a method for tracking an instrument's operation to demonstrate that data collected is within expected statistical variation and to ensure that potential failures and/or negative trends are identified early.

#### 4. Significance and Use

4.1 The purpose of this standard is to provide the user information and guidance for selecting and using instrumentation that will provide measurement results that can be compared to criteria for unrestricted use.

4.2 Use of this standard will provide greater assurance that the measurements obtained will be technically and administratively sufficient for making decisions regarding completion of decontamination and/or demolition/removal activities.

4.3 Use of this standard will provide greater assurance that the measurements obtained will be technically and administratively sufficient to meet all applicable regulatory requirements for unrestricted release of a component for recycle or reuse, or for unrestricted release of a remaining surface or area at the completion of decommissioning activities.

#### 5. Instrument Selection

##### 5.1 General:

5.1.1 Criteria for release of materials for recycling, re-use, or disposal, and of surfaces or areas remaining at the completion of decommissioning activities are set by regulatory authorities. For surface contamination and selected volumetrically contaminated media, values provided by the Nuclear Regulatory Commission (NRC) have been generally applied to licensed facilities, both NRC and Agreement State licenses (1,2). The Department of Energy (DOE) applies standards that are essentially equivalent to those provided by the NRC (3). The Environmental Protection Agency (EPA) and NRC have developed criteria that are risk-based, resulting in radionuclide and pathway specific release values that will be applied to decommissioning activities.

5.1.2 *In situ* radioactive measurements related to unrestricted release to be treated in this standard include:

5.1.2.1 surface contamination measurements

5.1.2.2 measurements of radionuclide concentrations in media

5.1.2.3 dose-rate measurements

##### 5.2 General Selection Criteria:

5.2.1 The instrument to be utilized must provide an output signal that can be correlated to the appropriate release criteria applicable to the residual source characteristics; e.g., surface emission rate, specific or total activity, dose rate.

5.2.2 The characteristics and performance of the measuring instruments should be evaluated against the specifications described in ANSI N42.17 and N42.17C. This should include documentation that the instrument satisfies the calibration requirements described in ANSI N323. NCRP 112 provides additional supplemental guidance on survey instrument calibration.

5.2.3 Documentation should be available that verifies that the applicable specification requirements described in ANSI N323 for the particular measurement conditions have been met for the instrument selected; e.g., minimum sensitivity, energy response, environmental response, etc.

5.3 Minimum Sensitivity (minimum detectable activity). The minimum sensitivity of the instrument selected should be  $\leq 50$  percent of the applicable release criteria to which the measurement results will be compared. (Appendix A provides further information for determining this.)

5.4 Energy Response. An instrument, selected for a particular residual radionuclide particle emission, should be calibrated for response to the energy of that emission. General guidance for determining this is found in ANSI N323.

5.4.1 Photon Energy Response. In addition to the general provisions in ANSI N323, descriptions of reference sources for making the photon energy response determination are found in ISO-4037.

5.4.2 Beta Energy Response. In addition to the general provisions in ANSI N323, descriptions of reference sources for making the beta energy response determination are found in ISO-6980 and ISO-8769.

5.5 Surface Contamination Detection. Residual surface contamination should be evaluated using either alpha or beta detectors. For performing "hot spot" location surveys, the detector shall be coupled to a ratemeter for performing transient (scanning) surveys. For performing a residual activity (stationary) assessment, the probe may be coupled to either a ratemeter or a scaler (see Section 6.3.4).

5.5.1 When performing scan surveys, the alpha or beta probe window areas should be  $\geq 100 \text{ cm}^2$ .

NOTE 1—Smaller detector probes may be used to perform scan surveys where accessibility prevents utilization of larger probe sizes in accordance with scan requirements described in Section 6.4.1.

5.5.2 When performing stationary assessments, the probe window area should be  $100 \text{ cm}^2 \pm 30\%$ . Refer to Appendix X2 discussion on the effect of probe size on minimum detection.

NOTE 2—The probe area that is to be used in any measurement interpretation is the total window area, *not* the effective open window area.

5.5.2.1 Additional guidance for instrument selection to perform surface contamination measurements is provided for the following residual activities:

5.5.2.2 alpha and beta ( $E > 0.15 \text{ MeV}$ ) emitters - ISO 7503-1

5.5.2.3 tritium - ISO 7503-2

5.5.2.4 beta ( $E < 0.15 \text{ MeV}$ ), isometric transition, and electron capture emitters - ISO 7503-3.

5.6 *Specific Activity Measurements*—The *in situ* measurement of the residual activity distributed within a volumetric medium of interest shall be based on the photon emission rate from that medium. The results of the evaluations of this photon emission rate are normally expressed in units of picocuries per gram (pCi/gm) or becquerels per gram (Bq/gm). This evaluation will be dependent on the background response of the detector and on a conversion factor established for the medium of interest. Nonuniform distributed source geometries can



result in large interpretation errors of *in situ* measurements; therefore, caution should be used with these evaluations.

5.6.1 *Background response*—The photon detector should have a response to background at the photon energy range of interest that will result in a minimum detectable activity that is  $\leq 50\%$  of the applicable release criteria. Guidance on calibration and use of crystalline (germanium and sodium-iodide) detectors is provided in ASTM E181.

5.6.2 *Background reduction*—The background response of the detector may be reduced by shielding or collimation. The shielding configuration should be selected to maximize response to the source configuration of interest, and may range from pin-hole collimation to selective shadow shielding.

5.6.3 *Conversion factor*—A conversion factor that will relate the *in situ* instrument response to the distributed source must be established. This may be done directly by sampling and analysis or by analytical modeling. The protocols for performing this determination are beyond the scope of this standard. Additional guidance for sampling and assessing residual activity in soil and low density scrap media are found in ASTM Standards C998-90 (4), C999-90 (5), C1000-90 (6), and C1133-89 (7).

## 6. Instrument Use

### 6.1 General Requirements:

6.1.1 Prior to using a particular instrument to assess the residual radioactivity, ensure that the instrument is appropriate for the emissions and environmental conditions present by reviewing the criteria discussed in Section 5 and identified references.

6.1.2 Prior to using a particular instrument, ensure that documentation is available that indicates that the instrument has been calibrated in accordance with the requirements specified in ANSI N323, and that the interval for recalibration has not been exceeded.

6.1.3 Prior to assessing the *in situ* measurements of the residual radioactivity, determine the natural radiological conditions for the site using one or more background reference areas. These areas shall be measured for:

6.1.3.1 radiological composition of media, such as air, water, soil, or structural material

6.1.3.2 amount of each primary radionuclide present

6.1.3.3 total terrestrial plus cosmic radiation dose rate

6.1.3.4 These areas are defined as having similar physical, chemical, biological, and geological characteristics as the areas to be assessed.

6.1.4 Determine the response of the instrument to the natural background and any background variations. The background response of the instrument shall be determined at a location representative of the area to be measured, but not affected by site operations. The NRC has drafted guidance for determining the background at a particular site (8).

### 6.2 Calibration:

#### 6.2.1 General Criteria:

6.2.2 A calibration source will normally be used to establish the conversion factor used to convert the instrument response to an estimate of *in situ* residual radioactivity. The calibration shall be performed such that an *in situ* measurement can be accurately converted to the  $4\pi$  (total) emission rate of the

residual surface activity. Factors important to this conversion are discussed in Appendix X5. The calibration sources used for this determination shall, as a minimum, have the following characteristics:

6.2.2.1 have the same type of emissions (alpha, beta, or photon) as the residual radioactivity

6.2.2.2 have particle or photon energy that is within  $\pm 10\%$  of the energy emitted from residual radioactivity. Alternately, calibration may be established from a curve generated from at least three sources with energies that bracket the energy of interest.

6.2.2.3 have a particle or photon emission rate that is no more than 50 times the applicable standard for unrestricted release

6.2.3 The calibration source should also have the following characteristics:

6.2.3.1 physical and/or chemical composition that produces similar backscatter characteristics as the residual *in situ* radioactive matrix, for example:

In situ medium	Source amount
iron/steel	steel
concrete	aluminum
wood/plaster	plastic
soil	aluminum

6.2.3.2 distribution (geometry) either within or on the surface that is similar to the residual radioactive matrix

#### 6.2.4 Special Criteria for Beta and Alpha Detectors:

6.2.4.1 In addition to the criteria described in Section 6.2.1, the conversion factors for beta and alpha detectors should also consider the following:

6.2.4.2 the distance between the calibration source and the detector must be the same as the distance that will be used to quantify the *in situ* field activity.

6.2.4.3 for quantifying a point source, a “point source efficiency” should be used with the conversion factor.

6.2.4.4 for quantifying a distributed area source, a “surface source efficiency” should be used. The surface source used to determine the conversion factor should match the size and shape of the detector probe window area (see Section 5.5.2), but should not be smaller than  $100\text{ cm}^2$  regardless of probe window area.

### 6.3 Source Checks:

6.3.1 Each instrument used to perform residual radioactive measurements shall be tested (at least daily, or before each use if it is used less often than daily) using a suitable check source to verify operability within the allowable parameters.

6.3.2 Prior to using a particular instrument to assess the residual radioactivity, the mean reference response and reproducibility of the instrument, as defined in ASTM C1215, shall be established following a specific protocol.

6.3.3 The daily verification, using the same protocol and check source, is compared to the mean response. If the daily check deviates from the mean by more than  $\pm 20\%$ , the instrument shall be removed from service for repair and/or recalibration (ANSI N323).

NOTE 3—Control charts should be used to track the daily response against the mean to observe trends and take action before the instrument reaches a predetermined “failure” point.

6.3.4 The check source used to perform the protocol shall not decay by more than 25 % of the applicable response limits used with the control chart throughout the duration of the measurement task.

6.4 *Surface Contamination Measurements:*

6.4.1 Residual radioactivity on surfaces may be located by transient measurements (scanning) and quantified by stationary (fixed) measurements.

6.4.2 Scanning-Surface Activity. Surfaces are scanned to identify the presence of elevated radiation which might indicate residual radioactivity or hot spots in excess of the levels that would permit unrestricted release. Measurement protocols have been described for performing scanning surveys by a federal interagency task group (9). The following requirements, as a minimum, should be followed when performing scan surveys for surface radioactivity:

6.4.2.1 Alpha and/or beta emissions should be measured, as applicable.

6.4.2.2 Large area detectors should be used for measuring flat surfaces; e.g., probe area  $\geq 100 \text{ cm}^2$ .

6.4.2.3 The detector response should be used with a ratemeter with a short electronic response time (time required to reach 90 % of steady state), preferably 2–4 seconds.

6.4.2.4 The distance between the detector and the surface should be maintained between 0.5 cm and 1.0 cm.

6.4.2.5 The scanning velocity should not exceed 1 detector width per second. This velocity should be reduced to as low as  $\frac{1}{2}$  detector width per second when the minimum response of the detector is near the unrestricted release guideline level. The effects of detector geometry, source geometry, and scanning velocity on detector response are shown in Appendix X2.

6.4.3 Scanning-Volumetric Activity: For residual radioactivity distributed within a matrix such that self-shielding effects significantly degrade or eliminate the alpha and beta emissions, residual activity must be identified using measurements of gamma emissions. The following requirements, as a minimum, should be followed when performing gamma scan surveys:

6.4.3.1 Crystalline or solid-state (e.g., sodium-iodide, germanium) detectors should be used with a ratemeter having a short electronic response time, preferably 2–4 seconds.

6.4.3.2 The distance between the detector and the survey area should not exceed 15 cm. Greater heights will reduce the sensitivity for detecting hot spots.

6.4.3.3 The scanning should be performed with the probe moved in a serpentine pattern approximately 1 m wide while advancing at a speed of approximately 0.5 meter per second.

6.4.4 Audio Response. Audio output from the ratemeter is recommended to augment observations of meter fluctuations in the ratemeter reading. The audio signal is independent of the electronic time constant of the meter and is a more sensitive indicator of elevated activity, particularly for time constants > 4 seconds.

NOTE 4—Experiments using hidden sources (Co-57) with signal-to-background ratios from 0.6-6 resulted in approximately 75 % being located based on ratemeter observation alone, compared to approximately 90 % for audio response (10).

6.4.5 Direct (fixed) Measurements. The estimate of the level of residual radioactivity is based on a measurement with the

source-detector geometry fixed (stationary). When making these fixed measurements, the following requirements, as a minimum, should be complied with:

6.4.5.1 The detector should be coupled to a scaler for this measurement.

6.4.5.2 If a ratemeter is used with this measurement, a long response time should be used (> 20 sec). The detector shall be kept in position for at least three times the time constant of the ratemeter.

6.4.5.3 The effects of the concavity of the surfaces being measured on instrument efficiency shall be evaluated when the surface is not flat (examples are given in Appendix X5 for beta emissions).

6.4.5.4 For conditions where a visible layer of dirt, oxidation, or other coating cannot be removed, the effect on source-detector response shall be included for alpha and beta measurements (examples are given in Appendix X5 for beta emissions).

6.5 *Data Interpretation:*

6.5.1 *Alpha and Beta Emissions:*

6.5.2 The evaluation of surface activity for alpha or beta emissions (in dpm/100  $\text{cm}^2$ ) is given by the expression (ISO-7503-1)

$$A_s = \frac{(n - n_B)}{\epsilon_i \times \epsilon_s \times \frac{W}{100}}$$

where:

$n$  = total count rate in cpm

$n_B$  = background count rate in cpm

$\epsilon_i$  = instrument efficiency for alpha or beta radiation in cpm per dpm

$W$  = total physical window area of the detector in  $\text{cm}^2$

$\epsilon_s$  = source correction factor to account for differences between the calibration source and the residual activity, such as backscatter, self absorption, source protective coatings and/or surface coatings, geometry, etc. (unitless)

NOTE 5—The factor  $\epsilon_i$  may be defined for either a point source or a surface source. The point source efficiency should be used to quantify hot spots. The surface source efficiency should be used to evaluate surfaces without hot spots.

NOTE 6—Further explanation of the factor  $\epsilon_i$  and its relative magnitude are given in Appendix X5.

6.5.3 *Gamma Emissions:*

6.5.3.1 Gamma detection and subsequent interpretation is normally employed to evaluate the levels of residual activity that are distributed within a source matrix expressed as pCi/gm, Bq/kg, etc. For a uniformly distributed source, the volumetric source term is provided by the expression

$$S_v = \frac{n - n_B}{\epsilon_\gamma}$$

where:

$S_v$  = volumetric source term in pCi/gm

$n$  = total count rate in cpm

$n_B$  = background count rate in cpm

$\epsilon_\gamma$  = instrument efficiency for an infinitely distributed gamma source in cpm per pCi/gm.

NOTE 7—The gamma efficiency will normally be composed of two factors; a dose conversion in units of cpm/(mR/hr) measured with a known calibration source, and a source conversion factor in units of (mR/hr)/(pCi/gm) based on shielding theory. In general, the dose conversion factor for a particular detector is provided for a single photon energy, whereas,

the source conversion factor includes scattered photons (buildup) which leads to an estimate of the gamma source strength that is conservative. The response of various NaI detector geometries as a function of photon energy is shown in Appendix X9.

APPENDIXES

(Nonmandatory Information)

X1. MINIMUM DETECTABLE ACTIVITY (MDA)

X1.1 When measuring residual radioactivity at the completion of a D&D activity that must be within limits or guidelines that are very near to the levels that are present from natural background, the minimum amount of radioactivity that may be detected by a particular measurement system must be determined. With radiation measurement, the physical amount of the residual radiation source (pCi, dpm, Bq, etc.) is not directly measurable, but is observed as a measurement instrument response (digital counts, voltmeter deflection, etc.). Because radioactive decay follows statistical relationships, the statistics of detection and determination apply directly to the observed (or observable) signal (meter reading) and its associated random fluctuations. When measuring for the presence of low residual activity, one must distinguish between two fundamental aspects of the detection problem (10).

X1.2 Given a net signal that is greater in value than a similar signal that has been established as defining background, has a “real” activity above background been detected? (The “false positive” or Type I error)

X1.3 Given a completely specified measurement process, what is the minimum “real” activity that will produce an observed signal that will be detected? (The “false negative” or Type II error)

X1.4 The first aspect relates to making an *a posteriori* (after the fact) decision based upon the net signal(s) and a defined criterion for detection. This leads to the establishment of a “critical level” ( $L_c$ ) for which a signal exceeding this level will be interpreted as a residual activity with a probability  $\alpha$ , when in fact it is only background, (error of the first kind). Conversely, the second aspect relates to making an *a priori* (before the fact) estimate of the detection capabilities of the measurement process that yields a signal exceeding the critical level that is in fact from a “real” residual source of activity. This “detection limit” ( $L_D$ ) is the smallest value such that real residual radioactive material greater than  $L_D$  will be interpreted erroneously as background with a probability less than  $\beta$ . Mathematically these concepts are given as:

$$L_c = K_\alpha \sigma_0 + B_0 \tag{X1.1}$$

$$L_D = L_c + K_\beta \sigma_D \tag{X1.2}$$

where:

$\sigma$  = standard deviation

$K$  = statistical constant based error probability for normally distributed events

The relationships between  $L_c$  and  $L_D$  are shown on Fig. 1.

X1.5 The quantity  $L_c$  is used to test an experimental result,

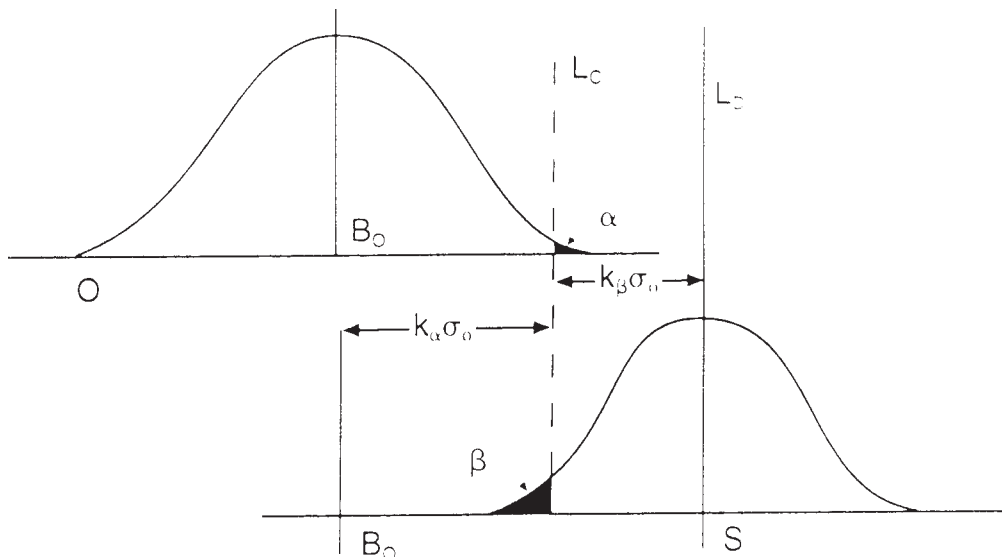

FIG. 1 Hypothesis Testing—Errors of the First and Second Kind

whereas  $L_D$  refers to the capability of the measurement process itself (10). The concept of “detection limit” ( $L_D$ ) has also been identified as “limit of detection” (11) and “minimum detectable activity” (MDA) (8). The term minimum detectable activity is most commonly encountered in radiation measurement reports, and will be utilized here. The basic relationship for estimating the MDA at the 95% confidence level is (19):

$$MDA = C_o (3.0 + 4.65 \sigma_o) \quad (X1.3)$$

where:

$C_o$  = proportionally constant relating the detector response to an activity

$\sigma_o$  = standard deviation of the background

For purposes of this discussion, MDA will be defined in units of activity expressed as dpm or pCi. This mathematical relationship for MDA will be applied to point source or “hot spot” residual. The concept of detection limit for distributed activity will be expressed using the “minimum surface sensitivity” (MSS) of the detector, which will incorporate the detector area as a function that will allow values of minimum surface sensitivity to be compared directly to surface activity regulatory guidelines.

X1.6 For time integrated measurements using a scaler readout:

$$MSS = \frac{3.0 + 4.65 \sqrt{B_o * t}}{t \cdot \epsilon_o \cdot (A_d/100)} \quad (X1.4)$$

For measurements involving a ratemeter signal, the relationship is:

$$MSS = \frac{4.65 \sqrt{B_o/2\tau}}{\epsilon_o \cdot (A_d/100)} \quad (X1.5)$$

where:

$B_o$  = background count rate (cpm)

$A_d$  = window area of detector probe (cm<sup>2</sup>)

$\epsilon_o$  = detector efficiency in counts/disintegration (includes all source surface and self attenuation effects - see Appendix X5)

$t$  = scaler count time (min)

$\tau$  = ratemeter time constant (min)

X1.7 Typical minimum sensitivities for scalers and ratemeters using common detector types are shown in Table X1.1.

## X2. DETECTION OF LOW-LEVEL RESIDUAL ACTIVITY

X2.1 The ability to evaluate the existence and amount of low-level residual activity in the presence of natural radioactive background is dependent on both the electromechanical characteristics of the detector system and upon the protocols by which the detector system is employed. At the completion of D&D activities, the most commonly utilized protocol for assessing the residual activity level is to employ a detector, coupled to a scaler, to obtain measurements on a fixed set of grid locations. For this type of measurement, one must know the minimum sensitivity of the detector system for comparison to guidelines that must be met. However, this technique is only

representative for uniformly distributed activity. It will not be effective for “hot” spot activity, particularly beta or alpha. For example, five measurements using a 100 cm<sup>2</sup> probe to characterize a 1 m × 1 m area will cover 5 percent of the surface being assessed. Even when applied at predetermined systematic or biased locations, it will only detect hot spots in a hit or miss fashion. Scanning, using the detector coupled to a ratemeter is the most effective method for locating “hot” spot activity. This technique however, is limited by the transient response characteristics of the detector and the ratemeter.

## X3. SCANNING EFFECTS - CONTAMINATION MONITORS

X3.1 The most common survey protocol utilized during D&D activities is scanning for the presence of residual radioactivity. This is accomplished by moving the radiation detector over the surface of interest. For radioactive source

levels very close to natural background levels, gamma monitors are not adequate for locating and assessing the presence of residual surface activity. Additionally, there are radionuclides of significance which decay by beta or alpha, with little or no

**TABLE X1.1 Typical Minimum Surface Sensitivities – Stationary Surveys**

Detector	Area (cm <sup>2</sup> )	Background (cpm)	Efficiency (counts/dis)	Minimum Surface Sensitivity (dpm/100cm <sup>2</sup> )	
				Scaler <sup>A</sup>	Ratemeter <sup>B</sup> (θ = 20 sec) <sup>C</sup>
Pancake GM	15.5	50	.30	760	1310
Large Area	128	300	.30	220	390
Floor Monitor	584	1000	.30	85	160
Alpha Scintillator	50	2	.15	120	160

<sup>A</sup> Derived from Eq X1.4, Appendix X1

<sup>B</sup> Derived from Eq X1.5, Appendix X1

<sup>C</sup> This is typical of analog ratemeters on “slow” response setting”

gamma emissions. For this reason, surface measurements for residual activity are performed using either beta or alpha survey meters. While these types of detectors are sufficiently sensitive to differentiate activity levels close to background, they are also more sensitive to the measurement protocols employed. The most significant variable effecting source detection and interpretation during scanning is source-detector geometry. Geometry will be a function of detector probe velocity, source and detector dimensions, and source-detector distance.

X3.2 For measurements, where the detector probe is in transient with respect to a low activity source of small size, the minimum sensitivity is dependent on several additional parameters such as detector probe velocity, source sizes, meter time constant and detector/surface distance. Detection of activity above background depends on the skill and senses of the surveyor to recognize an increase in either of two signal output modes: (1) deflection of the needle (analog) or sudden increase in counts (digital) on the ratemeter, or (2) the audio output of the instrument.

X3.3 The response of a detector probe to beta or alpha surface contamination is produced by particle interaction within the probe volume to produce a response signal. This is dependent on the particle “seeing” the opening (window) into the interactive volume. Fig. 2 illustrates the geometries involved.

X3.4 Consider this situation for a point source, as the detector probe passes over the surface. As the point source

location moves off-center with respect to the probe window, the particle must travel further and penetrate a greater thickness of intervening material (e.g., detector window) until the response diminishes beyond the edge of the window or is shielded by the detector wall.

X3.5 The response of a ratemeter to an input signal from a detector probe moving in relationship to the source is dependent, not only on the time the detector “sees” the source, but also on the response time of the meter electro-mechanical components to a transient input signal. For analog instruments, this is directly related to the RC time constant ( $\tau$ ) of the meter by the relationship where time response ( $\theta$ ) is defined as the time for the meter to reach 90% of steady state response.

$$R(\theta) / R(0) = 1 - e^{-\theta/\tau} \quad (X3.1)$$

where:

- R( $\theta$ ) = transient response of the meter to a fixed source
- R(0) = steady state response of the meter to a fixed source
- $\theta$  = response time of the meter
- $\tau$  = electronic time constant of the meter

X3.6 For digital rate meters, input pulses are gated to a register for a fixed time period. At the end of this time period, a fixed fraction of the register content is subtracted from the total. This cycle of accumulation for time T and fixed fraction subtraction F is repeated continuously until an equilibrium is exponentially approached where the rate pulses are added to the register is equal to the rate they are subtracted. This equivalent time constant is given by (17).

$$\tau = TF \quad (X3.2)$$

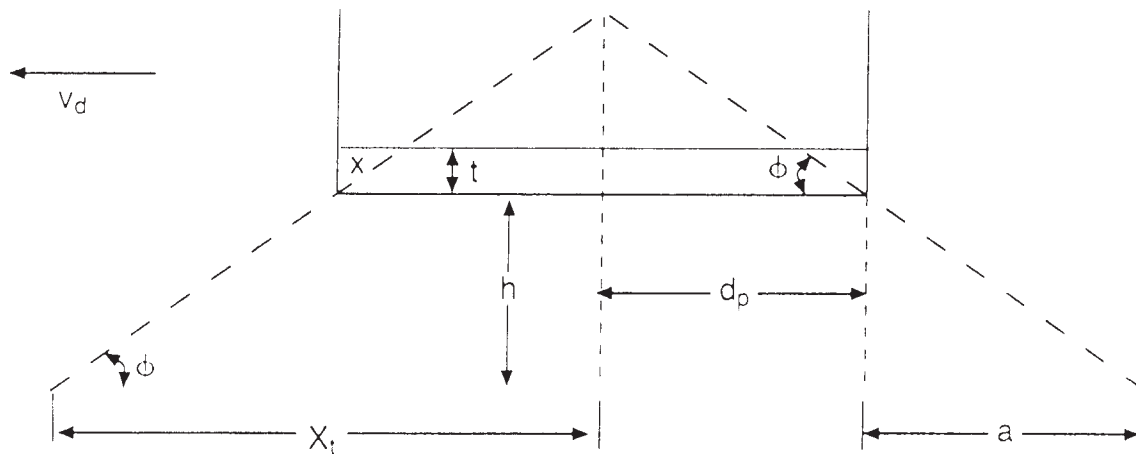

- h Distance from surface to probe
- t Apparent thickness of window, including screens
- $d_p$  Length of probe window in direction of travel
- $v_d$  Detector velocity

FIG. 2 Area of Detection



Where:

T = accumulation gating time

F = fraction of pulses subtracted at each step

X3.7 Most ratemeters in current use have a switch that allows operation in “fast” or “slow” time response mode. The following are typical ratemeter response times:

*Fast:*  $\theta_f = 2$  sec;  $\tau = 0.87$  sec (0.015 min)

*Slow:*  $\theta_s = 20$  sec;  $\tau = 8.7$  sec (0.15 min)

X3.8 When ratemeter output is utilized, the minimum sensitivity may be derived for point source activity and constant source/detector distance to account for the change in apparent detector efficiency as a function of probe velocity by the relationship.

$$\epsilon(V) = \epsilon_0 [1 - e^{-(d_p/v_d\tau)}] \quad (X3.3)$$

where:

$\epsilon(v)$  = “apparent” detector efficiency for detector velocity (v)

$\epsilon_0$  = detector efficiency for steady state source response

$d_p$  = distance detector probe travels with source within effective detection area (length of window in direction of travel)

$v_d$  = scanning velocity of the detector probe

$\tau$  = electronic time constant of the ratemeter

Equation Eq X1.5 would be modified for transient response as follows:

$$MSS = \frac{4.65 \sqrt{B_0/2\tau}}{\epsilon(v) \cdot (A_d/100)} \quad (X3.4)$$

X3.9 Fig. 3 illustrates the effects of different detector probe window sizes, and time responses on the transient response of the detector probe traveling at velocities up to 6-inches per second. Note that recommended practice is to scan at a probe velocity of 2-inches per second (5 cm/sec).

X3.10 When an audio output signal is used, experience has shown that a 25 % to 50 % increase may be easily identified at

ambient background levels of several thousand counts per minute (typical of gamma scintillators), but at ambient levels of 1–2 counts per minute (typical of alpha meters) a two to three fold increase in audible signal is required to be recognizable. These observations resulted in a conservative expression, based upon 3 times background:

$$MSS = \frac{3 \cdot B_0}{\epsilon_0 \cdot (A_d/100)} \quad (X3.5)$$

Other observers (13) have employed a term defined as minimum detection level (MDL) to denote the calculated minimum activity that can be detected using audio output during scanning. The MDL is based on the assumption that a doubling in the count rate can be recognized with the detector over the source for one second. This expression is:

$$MDL = \frac{B_0}{\epsilon_0 \cdot (A_d/100)} \quad (X3.6)$$

Table X1.1 presents a summary of estimated minimum sensitivities for various sizes of instruments used for beta and alpha detection using Equation Eq X1.4 for scaler and Equation Eq X1.5 for ratemeter. Minimum sensitivity is the term used to represent the “detection limit” for the ratemeters or scalers using the above expressions. For comparison, Table X3.1 presents a summary of estimated minimum sensitivities for these same instruments used with a ratemeter to perform scan surveys.

$$\text{Method 1 - MSS} = \frac{4.65 \sqrt{B_0/2\tau}}{\epsilon(v) \cdot (A_d/100)} \quad (X3.7)$$

$$\text{Method 2 - MSS} = \frac{(2B_0 - B_0)}{\epsilon_0 \cdot (A_d/100)} \quad (X3.8)$$

$$\text{Method 3 - MSS} = \frac{3B_0}{\epsilon_0 \cdot (A_d/100)} \quad (X3.9)$$

$\tau = 0.87$  sec (corresponds to a response time of 2 seconds)

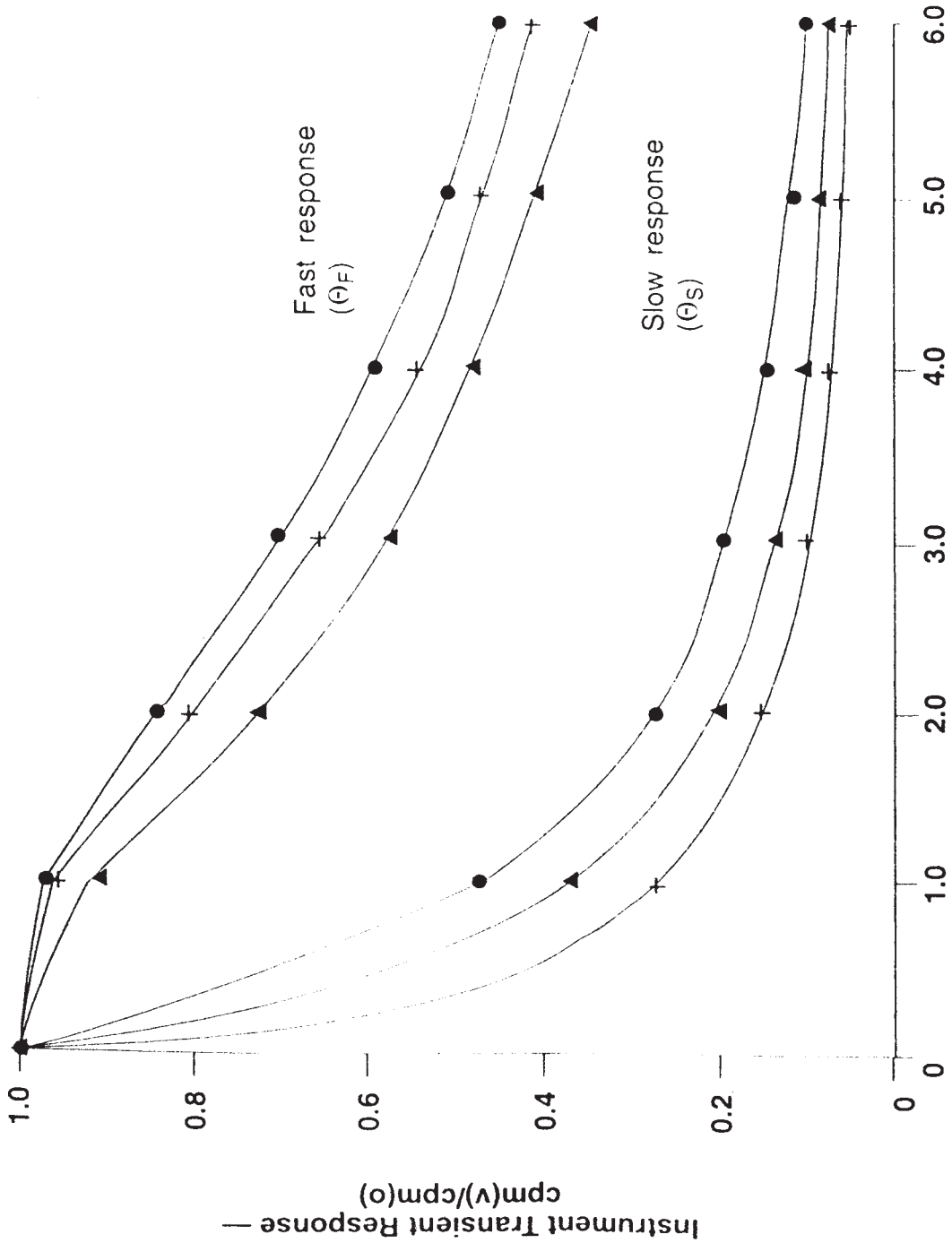

FIG. 3 Transient Response of Various Surface Contamination Detector Ratemeter Combinations

TABLE X3.1 Typical Minimum Surface Sensitivities – Scanning Survey

Detector	Area	Background (cpm)	Stationary Response (cpm/dpm)	Transient Response (cpm/dpm)	Minimum Surface Sensitivity (dpm/100cm <sup>2</sup> )		
					Method 1	Method 2	Method 3
Pancake GM	15.5	50	.30	.24	1660	1075	3225
Large Area	128.0	300	.30	.28	425	260	780
Floor Monitor	584.0	1000	.30	.29	160	570	1710
Alpha Scintillator	50.0	2	.15	.135	180	30	80

X4. EFFECTS OF SOURCE-DETECTOR GEOMETRY

X4.1 The theoretical relationships that relate dose rate as a function of source configuration, for both beta and photon particles, are derived for a point in space at some distance from the source. In other words, the detector is assumed to be a point in space. This is a reasonable assumption if the source-detector

distance is greater than five times the primary dimension of the detector ( $h > 5d_p$  in Fig. 2). Conversely, a small source size in relationship to the detector size may be treated as a point source if the above relationship is true with respect to the dimensions of the source. This is shown for two different

$$R(Z)/R(o) = \Omega(Z)/\Omega(o)$$

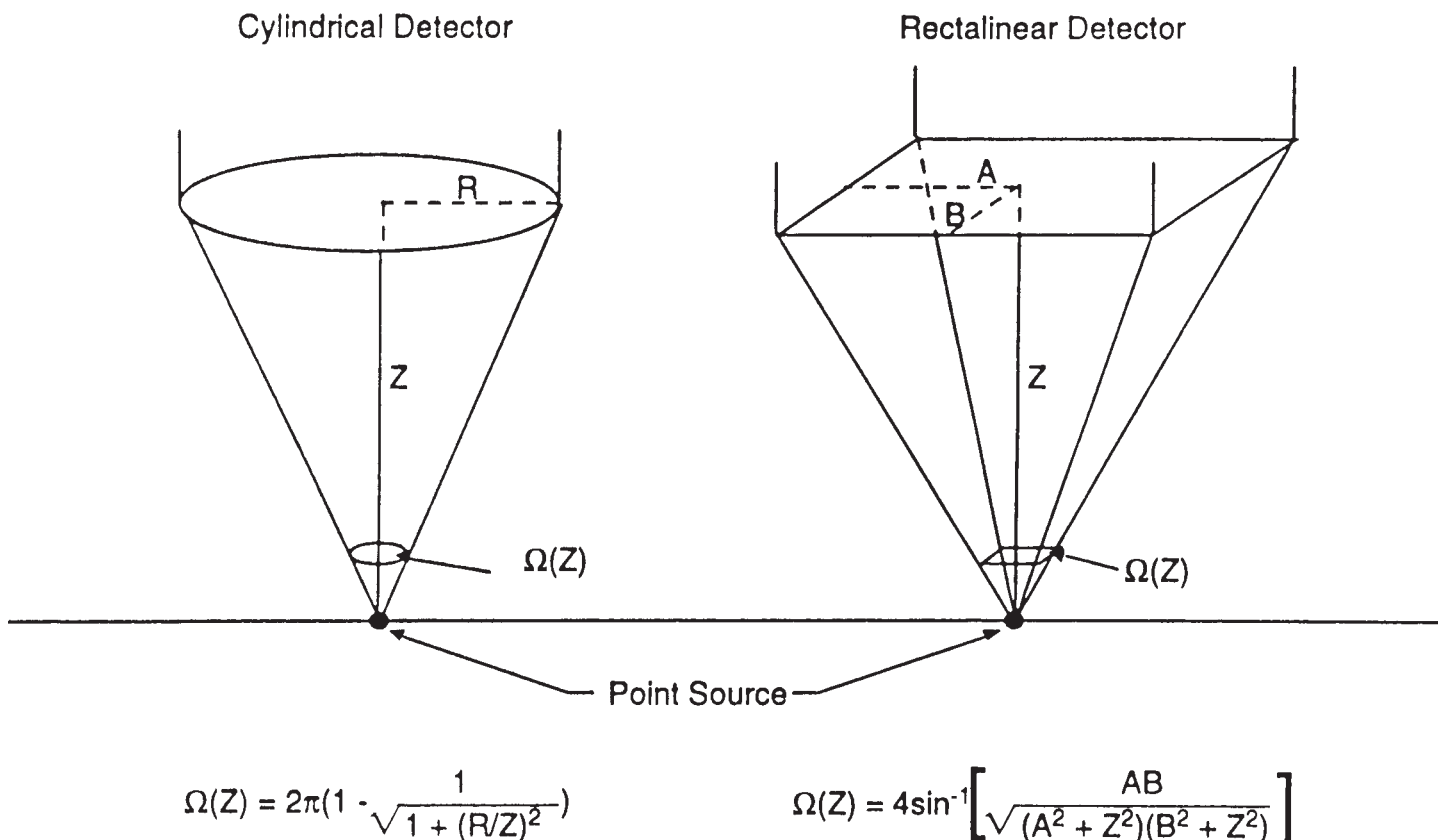

FIG. 4 Instrument Response as Function of Distance from Point Source

detector window geometries on Fig. 4.

X4.2 A series of beta measurements were obtained for different sizes at source-distances ranging from contact with the detector window to 2-inches for different source sizes (**15, 18**). The detectors used for this test were:

Pancake GM	$A_d = 15.5 \text{ cm}^2$
Large Area	$A_d = 128 \text{ cm}^2$
Floor Monitor	$A_d = 584 \text{ cm}^2$

X4.3 The sources used ranged in size from an active area of  $15 \text{ cm}^2$  to approximately  $250 \text{ cm}^2$ . The results of these measurements are shown on Fig. 5 and Fig. 6. On Fig. 5, the results are compared to point source theory. This figure confirms that point source theory is a valid relationship for

detector/source area ratios  $> 5$ . Note, however, the deviation from point source theory for the small detector probe area with respect to source size.

X4.4 Fig. 6 has not been correlated with theory. The curves shown are simply an attempt to “fit” the measured responses. The curves do, however, illustrate the reduction in response to a source that is equivalent in size to the detector as the detector distance from that source is changed. This factor is significant for small changes in scan height. For example, by increasing the scan height from  $\frac{1}{4}$  inch to  $\frac{1}{2}$  inch, the following reductions in scan efficiency could be anticipated:

Pancake GM:	~15 %
Large Area Probe:	~12 %
Floor Monitor:	~5 %



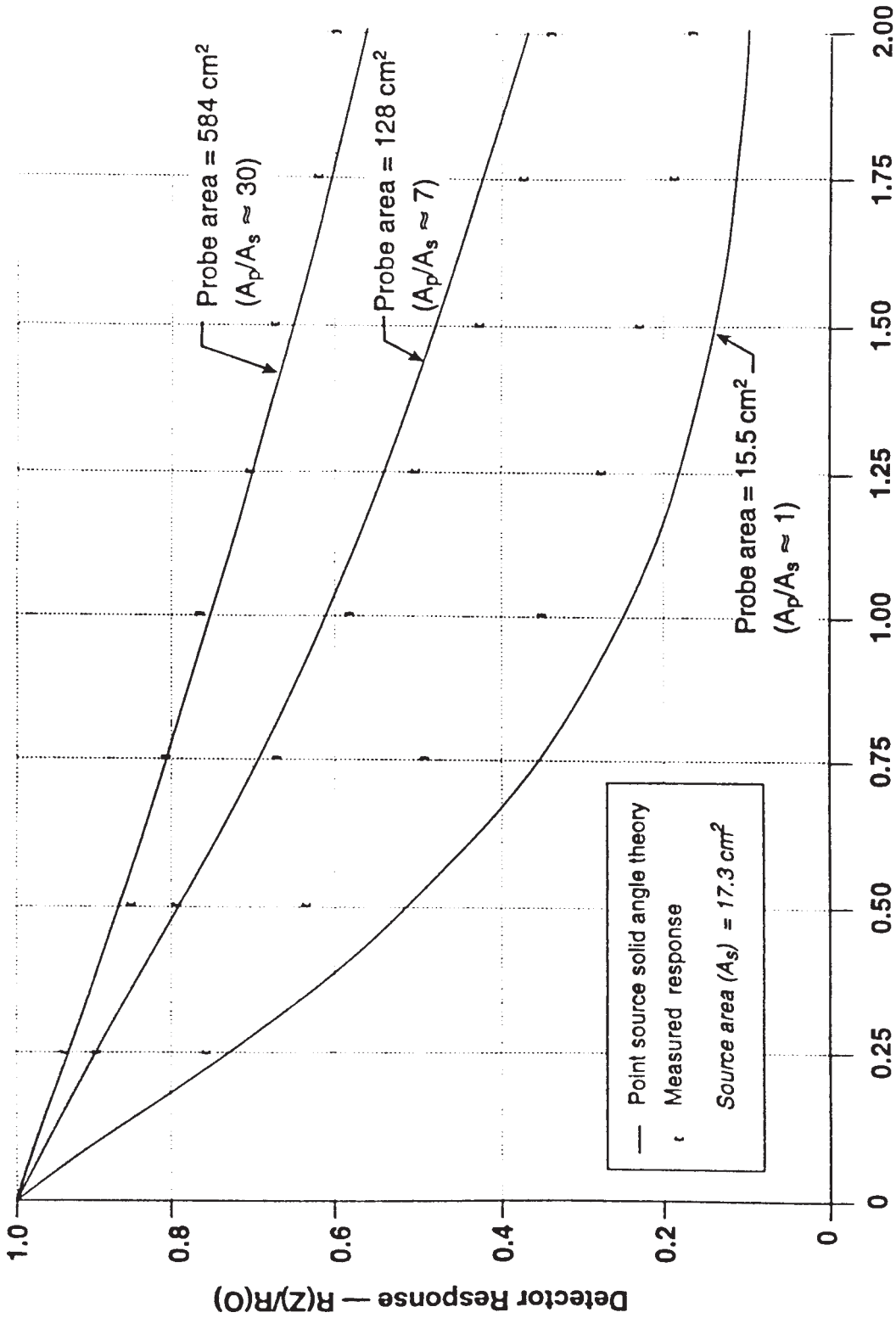
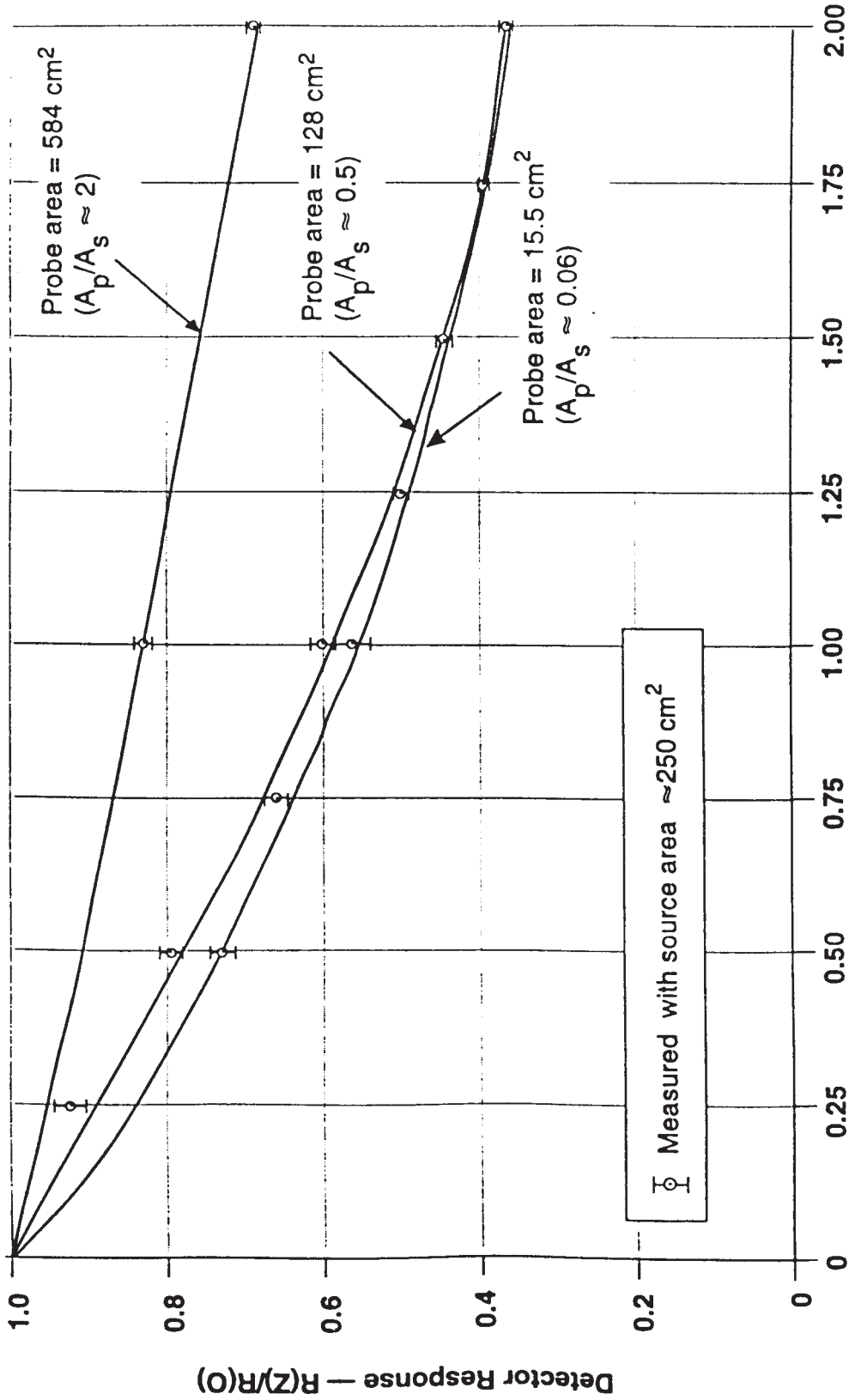

FIG. 5 Comparison of Detector Response to Point Source Theory for Various Probe Areas and a Small Area Source



Probe Height Distance from Surface (Z) — Inches

FIG. 6 Comparison of Detector Response for Various Probe Areas to a Large Area Source

**X5. FACTORS AFFECTING THE MEASUREMENT OF ALPHA AND BETA SURFACE CONTAMINATION**

X5.1 This appendix provides additional information on various characteristics of surface conditions that affect the evaluation of surface contamination level from an in situ detector response.

**GENERAL THEORY**

X5.2 The geometrical relationship between a particle detector and a source emitting those particles from a surface is shown on Fig. 7.

X5.3 Define the following parameters:

- $R_D$  = Detector response (cpm)
- $S_o$  = Total activity of source - (Bq, dpm)
- $S_T$  = Source emission rate -  $\beta/s$  or  $\alpha/s$
- $S_s$  =  $2\pi$  surface emission rate -  $\beta/s$  or  $\alpha/s$
- \* = Location of particle interaction by scattering or final absorption

X5.4 The relationship between total source activity (Bq) and source emission rate (particles/sec) is given by:

$$S_T = \epsilon_d S_o \tag{X5.1}$$

where:

$\epsilon_d$  = the decay efficiency or yield in particles per disintegration.

X5.5 In most field measurement situations  $\epsilon_d = 1.0$  so that  $S_T = S_o$ . For multiple particle emissions associated with an equilibrium decay daughter of the source activity (e.g., strontium-90/yttrium-90) this factor must be accounted for. From Fig. 7:

$$S_T = S_1 + S_2 + S_3 + S_4 + S_5 + S_6 \tag{X5.2}$$

$$S_s = S_1 + S_2 + S_3 + S_5 \tag{X5.3}$$

X5.6 Each component of the source is defined as:

$S_1$ —portion of emissions in *upper*  $2\pi$  solid angle that intersect the detector

$S_2$ —portion of emissions in *lower*  $2\pi$  solid angle that intersect the detectors by backscatter

$S_3$ —portion of emissions in *upper*  $2\pi$  solid angle that are absorbed between source and detector

$S_4$ —portion of emissions in *upper*  $2\pi$  solid angle that are absorbed within the source

$S_5$ —portion of emissions in *upper*  $2\pi$  solid angle that by-pass the detector

$S_6$ —portion of emissions in *lower*  $2\pi$  solid angle not “seen” by detector

X5.7 The objective of a radiation detector calibration is to enable an observer to correlate the response of the detector ( $R_D$ ) to a radiation source activity level ( $S_o$ ). This involves converting the detector response ( $R_D$ ) in counts per minute into a source activity ( $S_o$ ) in disintegrations per minute using a “calibration factor.”

$$\epsilon_o = R_D \text{ (cpm)} / S_o \text{ (dpm)} \tag{X5.4}$$

Following the protocol in ISO 7503-1, this factor may be described as part a product of:

$$\epsilon_o = \epsilon_i * \epsilon_s * \epsilon_d \tag{X5.5}$$

where:

$\epsilon_i$  = detector counting efficiency—fraction of ionizing particles intersecting the detectors volume that produce a signal

$\epsilon_s$  = source efficiency—fraction of particles emitted by the source that are emitted in the  $2\pi$  direction of the detector

$\epsilon_d$  = decay efficiency of the source (yield in particles per disintegration)

X5.8 The detector counting efficiency may be further reduced into a component that relates to the source-detector geometry and a factor that is a function of detector response to incident particle interaction.

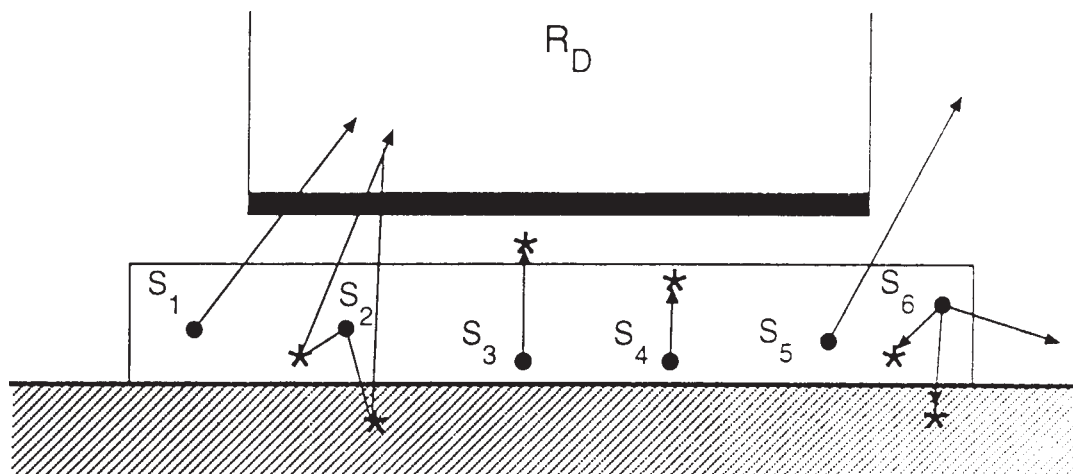

FIG. 7 Surface Source—Detector Geometry

$$\epsilon_i = \epsilon_g * \epsilon_e \quad (X5.6)$$

where:

$\epsilon_g$  = source-detector geometry factor—fraction of particles emitted in the  $2\pi$  direction of the detector that intersect the volume of the detector

$\epsilon_e$  = signal produced by detector for particles intersecting within the detector volume

X5.9 Algebraically, the “calibration factor” now becomes:

$$\epsilon_o = \epsilon_e * \epsilon_g * \epsilon_s * \epsilon_d \quad (X5.7)$$

where:

$$\epsilon_i = R_D / S_s = R_D / S_1 + S_2 + S_3 + S_5 = \epsilon_e * \epsilon_g$$

$$\epsilon_s = S_s / S_T = S_1 + S_2 + S_3 + S_5 / S_1 + S_2 + S_3 + S_5 + S_6$$

$$\epsilon_g = S_1 + S_2 / S_1 + S_2 + S_3 + S_5$$

$$\epsilon_e = R_D / S_1 + S_2$$

$$\epsilon_d = S_T / S_O$$

X5.10 For alpha and beta detection, each of the first three terms of Eq X5.5 include:

X5.10.1 detector response efficiency ( $\epsilon_e$ ) - attenuation through detector walls and window, interaction within detector ionization medium, etc.

X5.10.2 Source detector geometry factor ( $\epsilon_g$ )—solid angle between source and detector, air attenuation, particle scattering from surrounding structures, etc.

X5.10.3 Source geometry ( $\epsilon_s$ )—self-attenuation in source medium, shielding attenuation by protective coatings, backscatter from source surface medium, etc.

X5.11 For general use of the radiation detector calibration factor ( $\epsilon_o$ ) for measuring residual activity, the count rate (cpm) response of the detector per disintegration rate (dpm) of the calibration source must be the same as that for the residual activity:

$$\begin{aligned} \epsilon_o (\text{activity}) &= \epsilon_e * \epsilon_g * \epsilon_s * \epsilon_d (\text{activity}) = \\ \epsilon_o (\text{source}) &= \epsilon_e * \epsilon_g * \epsilon_s * \epsilon_d (\text{source}) \end{aligned} \quad (X5.8)$$

X5.12 This is true if, *and only if*, the following conditions are true:

X5.12.1 The beta energy of the residual surface activity or sample is equal to the calibration sources energy [the calibration source (S) is the same isotopic composition as the residual activity or sample (A)]:

$$\epsilon_d (A) * \epsilon_e (A) = \epsilon_d (S) * \epsilon_e (S) \quad (X5.9)$$

X5.12.2 The source/detector geometry is the same for the calibration source as the samples or surfaces to be analyzed [maintain the same geometry for the calibration source and the surface or sample]

$$\epsilon_g (A) = \epsilon_g (S) \quad (X5.10)$$

X5.12.3 The composition of the residual surface activity or sample is the same as the calibration source [calibration source is fabricated identically to unknown sample geometry and composition]:

$$\epsilon_s (A) = \epsilon_s (S) \quad (X5.11)$$

X5.13 The condition in X5.12.1 is usually (but not always)

met by using a calibration source with the same radionuclide as the anticipated field activity or by establishing a response vs. particle energy relationship for the detector and correcting for yield, when necessary.

X5.14 The condition in X5.12.2 requires that the distribution of the source be considered as well as the relative position of the source and the detector. Two source detector geometry factors are ordinarily determined:

X5.14.1  $\epsilon_{gp}$  (S) for a point source when the source is smaller than the detector

X5.14.2  $\epsilon_{gd}$  (S) for a distributed source

X5.14.3 The former is used when the residual activity is confined to an area smaller than the detector and the latter when the residual activity is distributed over an area that is greater than the detector area. A correction must be made for distributed residual activity if  $\epsilon_{gp}$  (S) for a point source is the only known calibration.

X5.15 The condition in X5.12.3 is rarely, if ever, met. To meet this condition, the following circumstances are normally necessary in order to convert from calibration source response to field interpretation:

X5.15.1 Backscatter of source = backscatter of residual activity

X5.15.2 Self-attenuation of source = self-attenuation of residual activity

X5.15.3 Surface condition of source = surface condition of residual activity

X5.16 The first two conditions are normally achieved by selecting a calibration source of the same isotopic composition as that of the unknown sources, and by maintaining the same counting geometry for both calibration and unknown source measurements. The third condition can only be met if the material and thickness of the calibration source is fabricated to reproduce those properties of the matrix containing the residual activity. This third condition is not usually attained in counting lab or in *in situ* measurement operations and must, therefore, be accounted for as a correction factor in the calibration procedure.

X5.17 The problem is further compounded in that beta calibration sources are normally specified by one of the following parameters:

X5.17.1 total disintegration rate or contained microcuries,  $S_o$  (dpm)

X5.17.2  $4\pi$  particle emission rate,  $S_T(4\pi-\beta/m)$

X5.17.3  $2\pi$  or surface, emission rate,  $S_s(2\pi-\beta/m)$

X5.18 In beta counting operations, the first two parameters are utilized to obtain an overall calibration factor, or “beta efficiency,” for the counting system. The third parameter is normally associated with sources mounted on a planchet. Depending on which of the above parameters are specified, the standard approach for establishing the beta calibration factor ( $\epsilon_o$ ) is determined by comparing the detector response to one of the source activity parameters as follows:





$$\begin{aligned} \epsilon_o &= R_d(\text{cpm}) / S_o(\text{dpm}) \\ \epsilon_o &= R_d(\text{cpm}) / S_T(4\pi - \beta / \text{m}) \\ \text{for } \epsilon_d &= 1.0 \end{aligned} \quad (\text{X5.12})$$

$$\epsilon_o = R_d(\text{cpm}) / \frac{2 S_s(2\pi - \beta / \text{m})}{(1 + f_b)} \quad (\text{X5.13})$$

where:

$f_b$  = Beta backscatter factor (see Fig. 8)

X5.19 To illustrate these points, consider a beta calibration source that is obtained with the same radionuclide expected in the uncharacterized activity and provides the same source/detector geometry as the field measurements. Before proceeding, however, two further considerations must be addressed:

X5.19.1 The relationship between the parameter that describes the calibration source activity and the total activity ( $S_o$ ) of the source.

X5.19.2 The relationship between the calibration source configuration and that of the unknown field source activity.

X5.20 If both conditions provide equivalence, a beta

calibration factor may be established and field measurement analysis can proceed. However, this is not usually the case.

X5.21 The parameter of interest is the total contained activity ( $S_o$ ) is the unknown field source. To determine this parameter, the value of  $S_o$  (dpm) in the calibration source (refer to Eq X5.2) must be known *or* a determination made of that parameter from a known value of  $S_s$  ( $\beta / \text{m}$ ) and the source geometry parameters. Since most beta calibration sources are certified by measuring  $S_s$ , the value of  $S_o$  may be determined by independent gamma analysis (for a  $\beta/\gamma$  source). However, this is not possible for a pure beta emitter, such as strontium/yttrium-90.

X5.22 The parameter that is most easily attained from the calibration source is detector counting efficiency ( $\epsilon_i$ ).

$$\epsilon_i = R_D/S_S \quad (\text{X5.14})$$

An example of this parameter is shown on Fig. 9 for two beta detector sizes. Factors that will modify this parameter, and additional factors for field source characteristics are presented in the following sections.

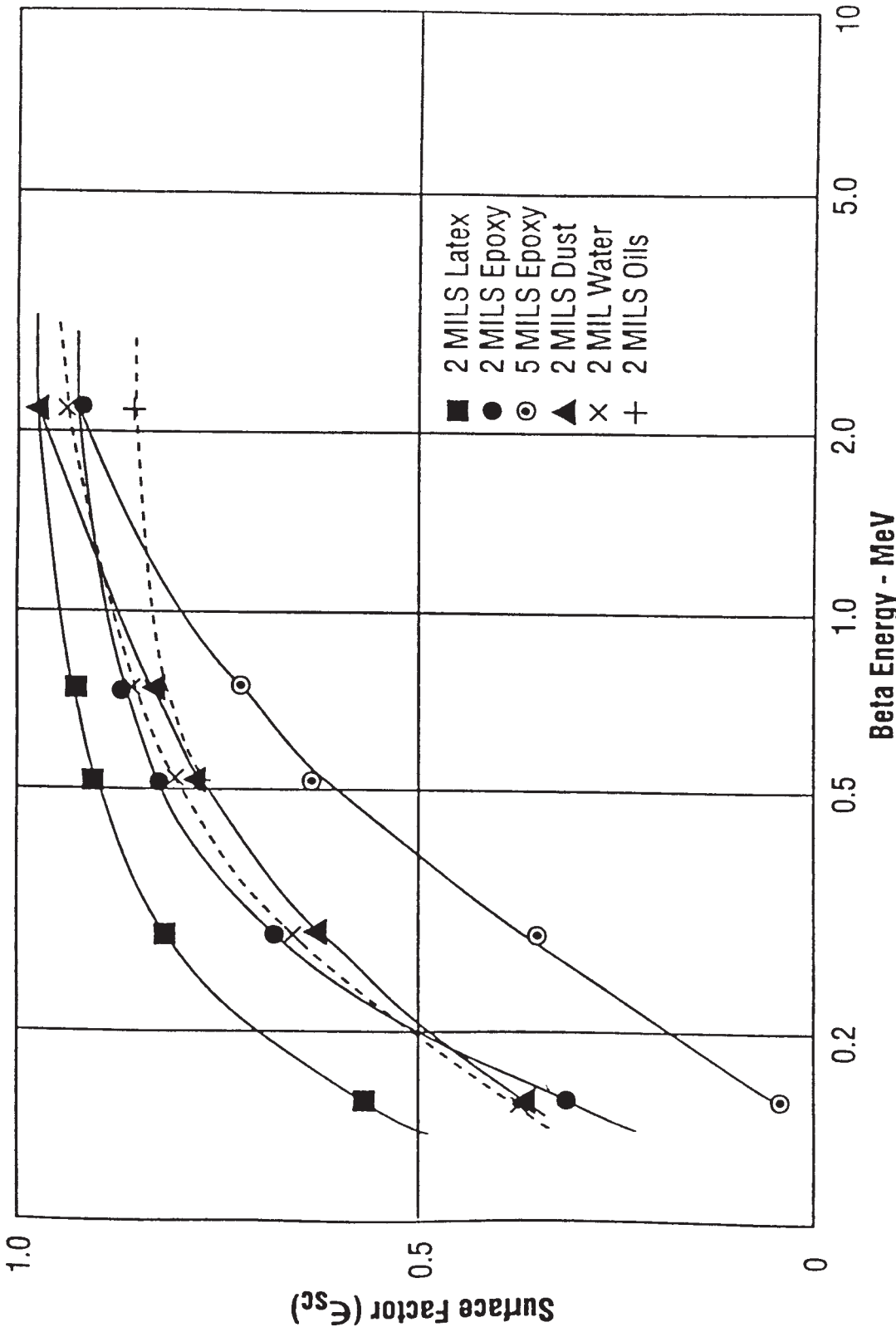

FIG. 8 Beta Measurement Surface Factor ( $\epsilon_{sc}$ )

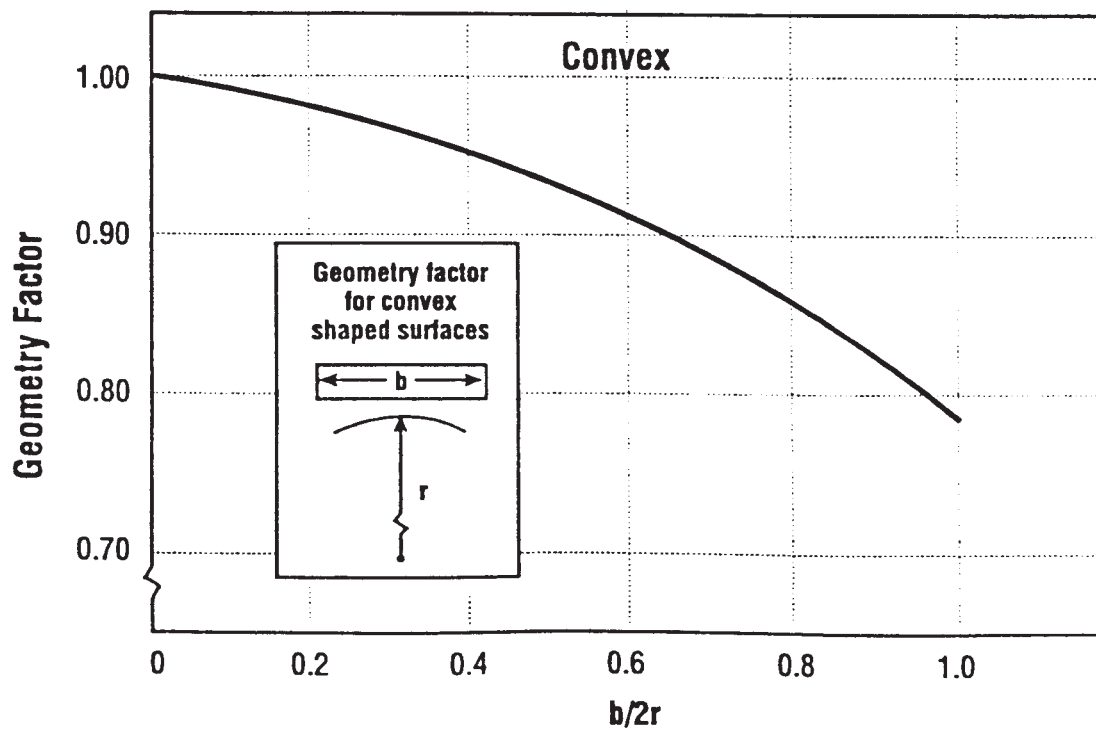
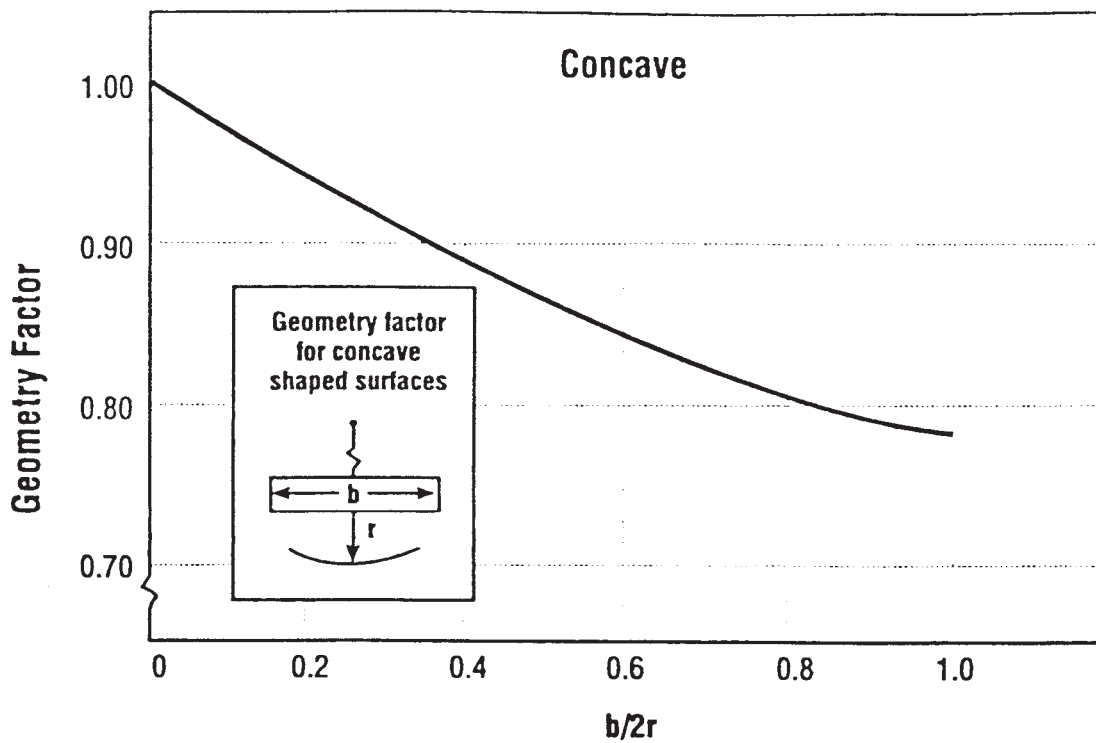

FIG. 9 Loss of Beta Counting from Source Surface No Air Attenuation

X6. GEOMETRY CORRECTIONS

X6.1 Generally, *in situ* measurements are made on flat surfaces using a “flat” faced detector calibrated with a flat surface source. However, many surfaces for which an *in situ* measurement is desired are curved with respect to the detector face. Fig. 10 presents a typical attenuation loss for beta measurements on a curved surface. This figure presents the

geometry factor ( $\epsilon_g$ ) by which the field measurement should be corrected as a function of the detector-to-surface relationship for a convex and a concave surface (16). This figure illustrates that as the radius of curvature of the surface exceeds approximately five (5) times the detector tangential dimension (another shielding rule of thumb), the effect of surface curvature

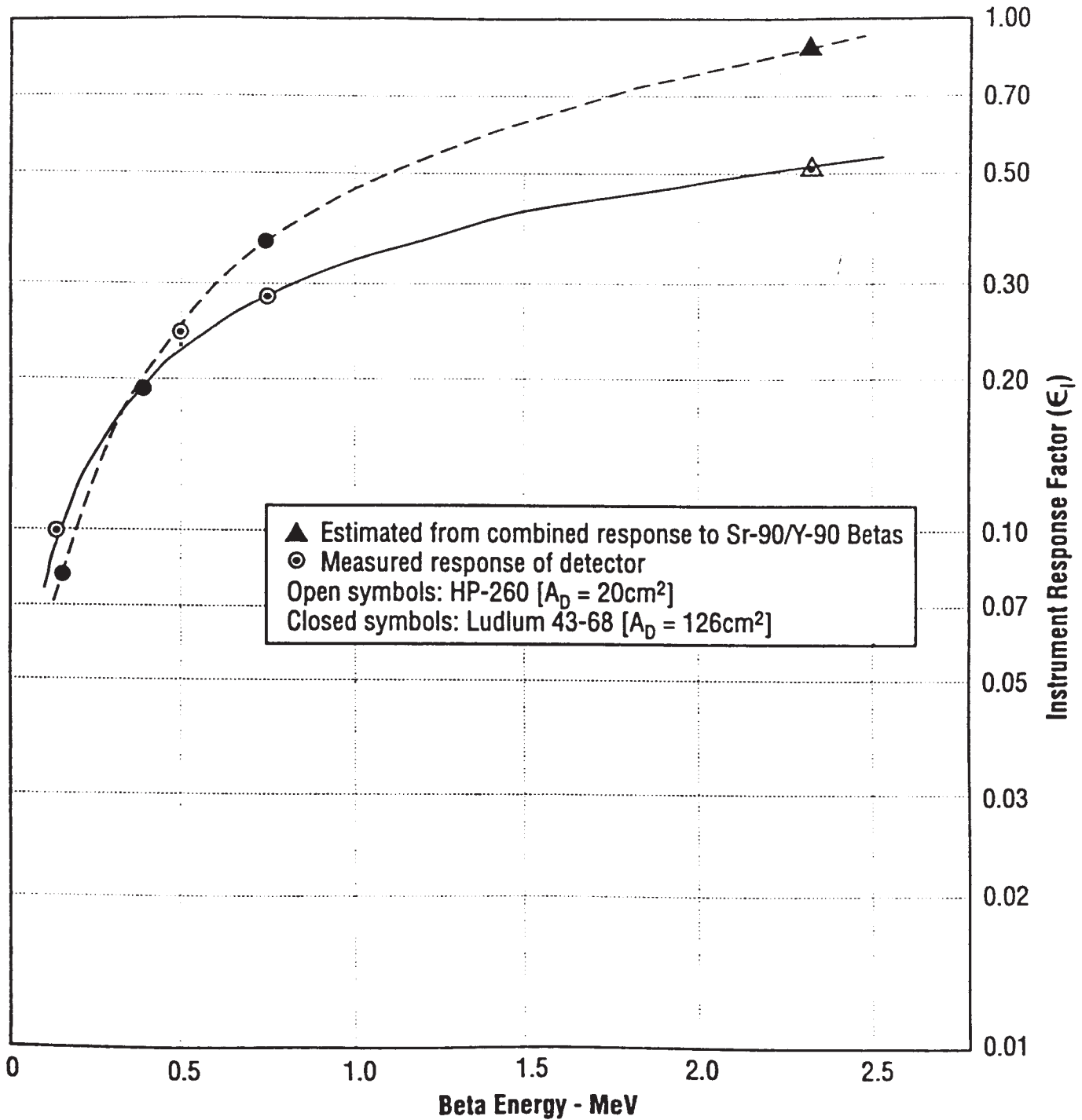

FIG. 10 Beta Instrument Response Factor ( $\epsilon_1$ )



becomes negligible.

## X7. SURFACE COATING EFFECTS

X7.1 Frequently, in situ measurements are made on surfaces that have coatings or surface films, the effects of which will not be accounted for with the “calibration” factor  $\epsilon_o$ . Surface films commonly encountered include, paint, dust, water film, oil film, metallic corrosion, etc. The attenuation effects of various coating types encountered during in situ measurements are shown in Fig. 8 as a function of beta and

point energy (**18**). Fig. 11 shows the attenuation of thorium-230 ( $E_\alpha = 4.65$  MeV) for various attenuating materials as a function of the material shielding thickness (**18**). The surface coating factor ( $\epsilon_{sc}$ ) must be included in the beta “calibration factor”  $\epsilon_o$  used to interpret the field measurements

$$\epsilon_o (A) = \epsilon_o (S) \cdot \epsilon_{sc} \quad (X7.1)$$

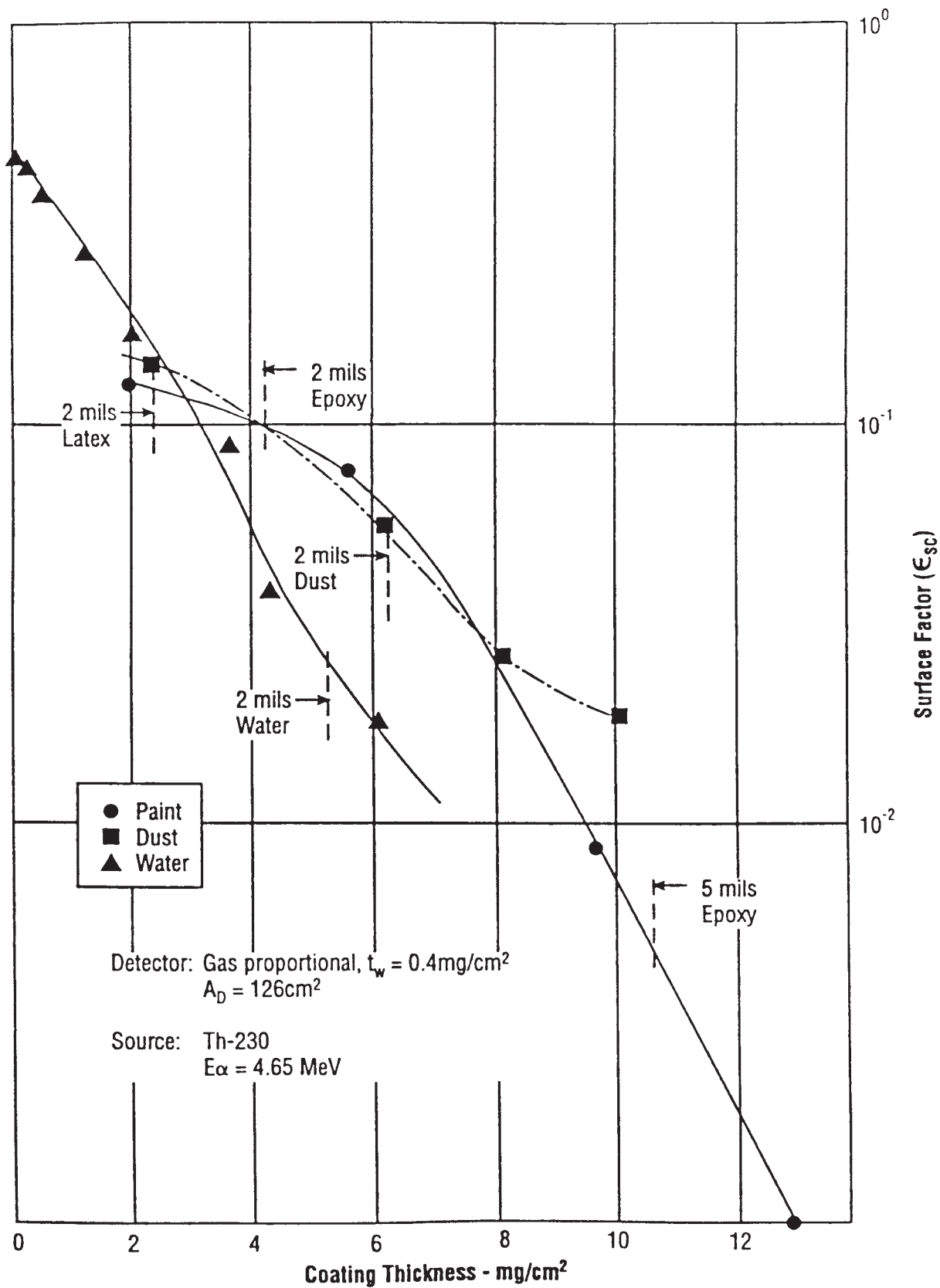

FIG. 11 Alpha Measurement Surface Factor ( $\epsilon_{sc}$ )

## X8. SURFACE BACKSCATTER EFFECTS

X8.1 A radioactive source on a solid surface will have a portion of the decay particles initially emitted toward that surface scattered back in the opposite direction. This “backscatter” occurs for photons, beta particles, and alpha particles. Backscatter ( $f_b$ ) for photons is typically a fraction of a percent of the initial forward flux. Backscatter for alpha particles is typically a few percent. Backscatter is usually ignored for interpreting photon and alpha measurements. Beta backscatter however is much more significant, with factors of up to 50 % observed dependent on beta particle energy and the electron density ( $Z$ ) of the backscatter media. This factor must be properly accounted for to evaluate beta measurements. This is done by adding the backscatter fraction ( $f_b$ ) to the beta particle emissions away from the surface. Referring to Fig. 7, the backscatter source is defined as  $S_2$  and the forward ( $2\pi$ ) source is  $S_T/2$ , where  $S_2 = f_b (S_T/2)$ . Then

$$S_s = \frac{S_T}{2} + S_2, \text{ or} \quad (\text{X8.1})$$

$$S_s = \frac{S_T}{2} (1 + f_b) \quad (\text{X8.2})$$

X8.2 Fig. 12 shows typical backscatter ( $1 + f_b$ ) effects for various surfaces as a function of incident beta energy. From Equation Eq X5.1, a surface source efficiency ( $\epsilon_s$ ) for a surface activity having negligible self-absorption ( $S_4 \approx 0$ ) is defined as:

$$\epsilon_s = S_s/S_T = \frac{1}{2} (1 + f_b) \quad (\text{X8.3})$$

X8.3 If the beta calibration factor  $\epsilon_o$  was determined using a calibration source with a different scattering medium than encountered with field measurements, this source calibration factor  $\epsilon_o$  (s) must be corrected by:

$$\epsilon_o (A) = \epsilon_o (S) \frac{(1 + f_b)_A}{(1 + f_b)_S} \quad (\text{X8.4})$$

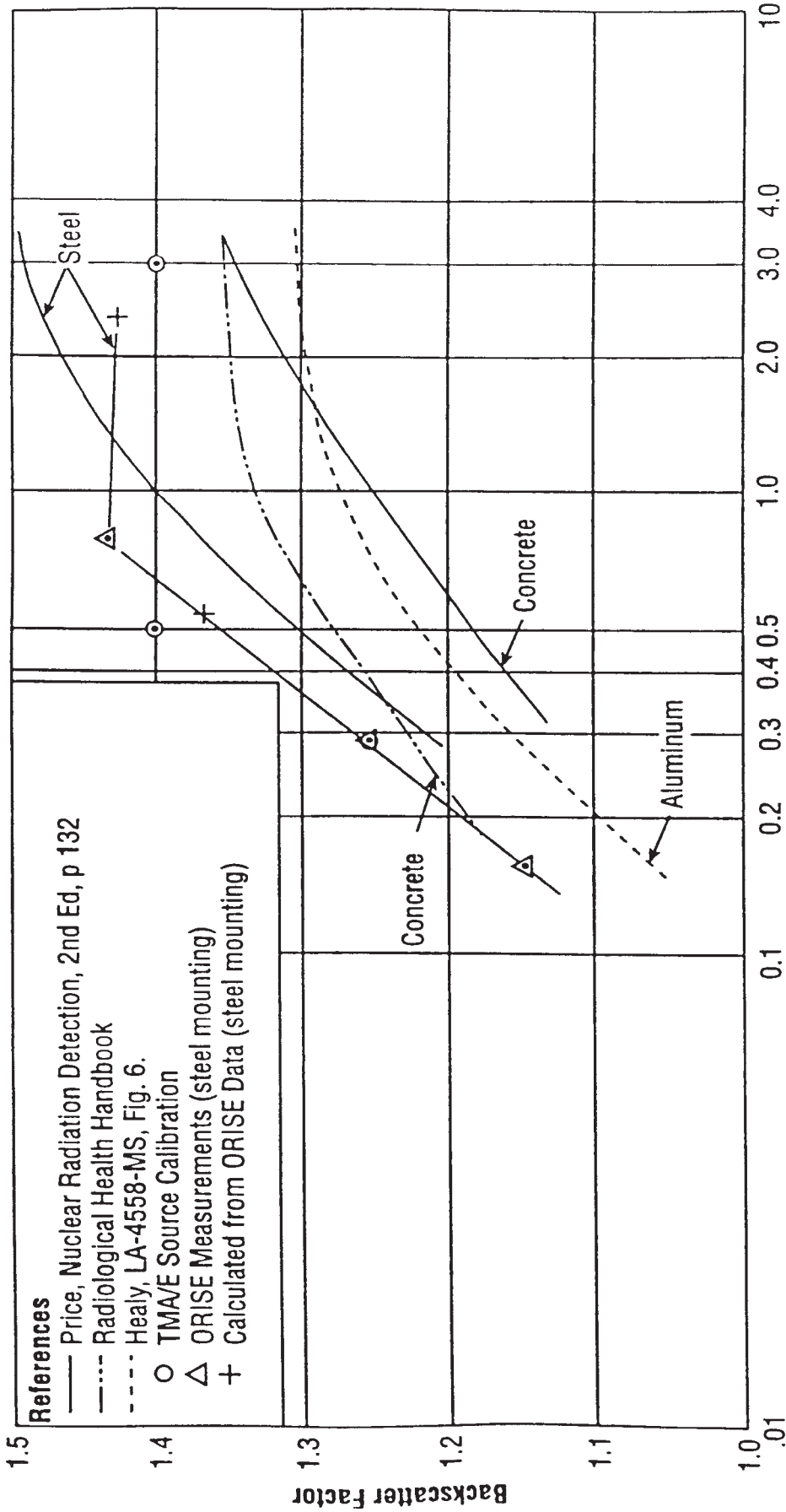

FIG. 12 Beta Backscatter from Various Surfaces

## X9. FACTORS AFFECTING THE MEASUREMENT OF GAMMA ACTIVITY

X9.1 The most common in situ measurement evaluation using gamma detection is estimating the activity concentration in the measured medium (i.e., soil concentration). Alpha or beta measurements are not practical for estimating activity concentrations in a thick absorbing medium. For detecting activity levels that are near background, scintillation detectors are generally employed because of their high level of response to low levels of residual activity. Activity concentration for scintillator detectors may be determined by using the expression:

$$S_v = \frac{n - n_B}{K_\gamma \cdot \xi_\gamma} \text{ (pCi/gm)} \quad (\text{X9.1})$$

where:

$n$  = total detector count rate (cpm)

$n_B$  = background count rate (cpm)

$\xi_\gamma$  = detector response factor (cpm/  $\mu\text{R/hr}$ ) dependent on emission energy

$K_\gamma$  = dose rate constant ( $\mu\text{R/hr}$ ) (pCi/gm) dependent on source depth distribution and emission energy

X9.2 Fig. 13 and Fig. 14 illustrate detector response as a function of photon energy for a variety of sodium-iodide (NaI) scintillator detectors of various geometries. The dose rate constant  $K_\gamma$  is a function of source-detector geometry and photon energy, and may be determined from shielding theory for the photon energy or isotope of interest. Fig. 15 illustrates this relationship for a radium-226 source uniformly distributed in a soil matrix.

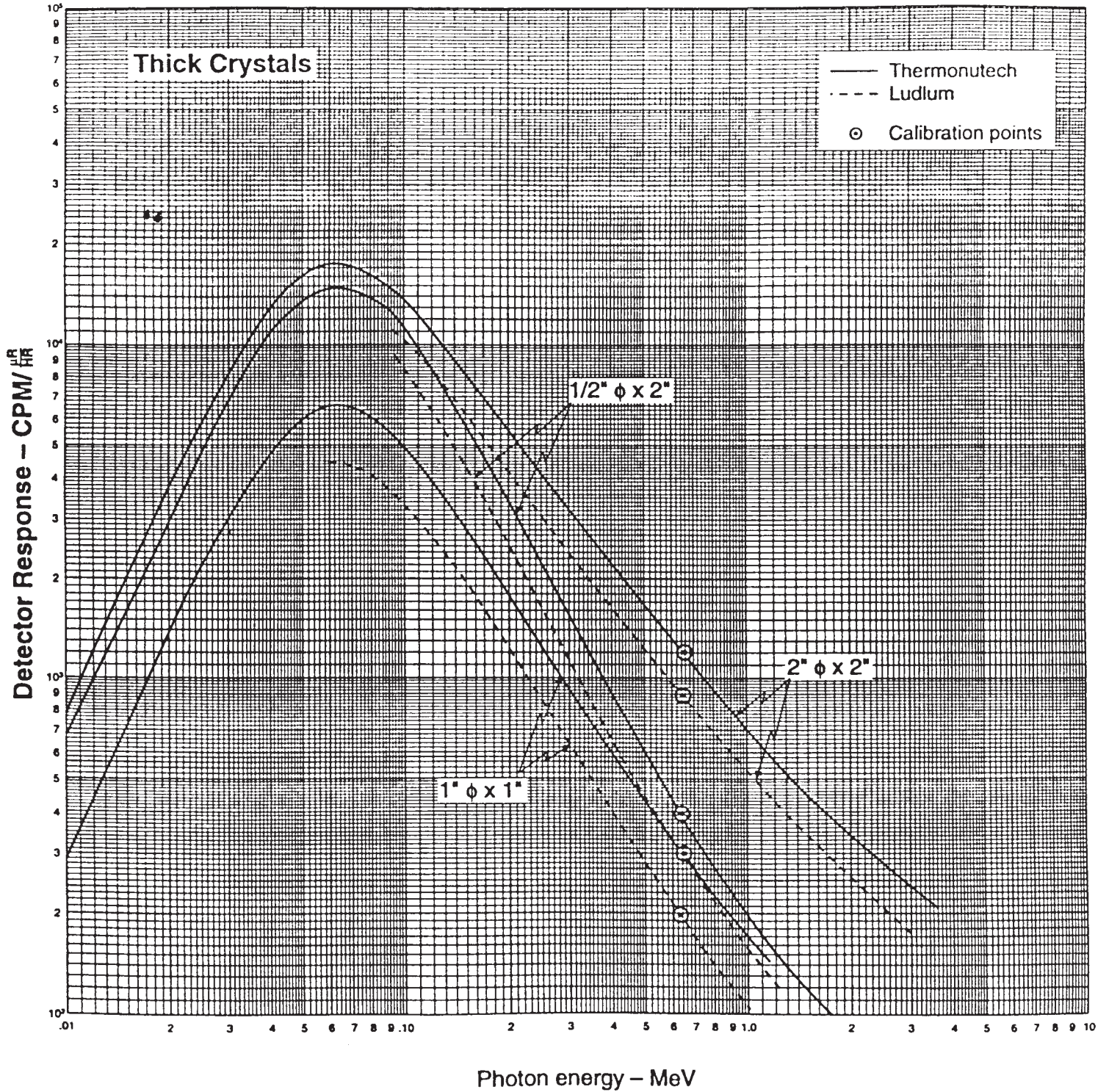

FIG. 13 Response vs Photon Energy for NaI Detectors



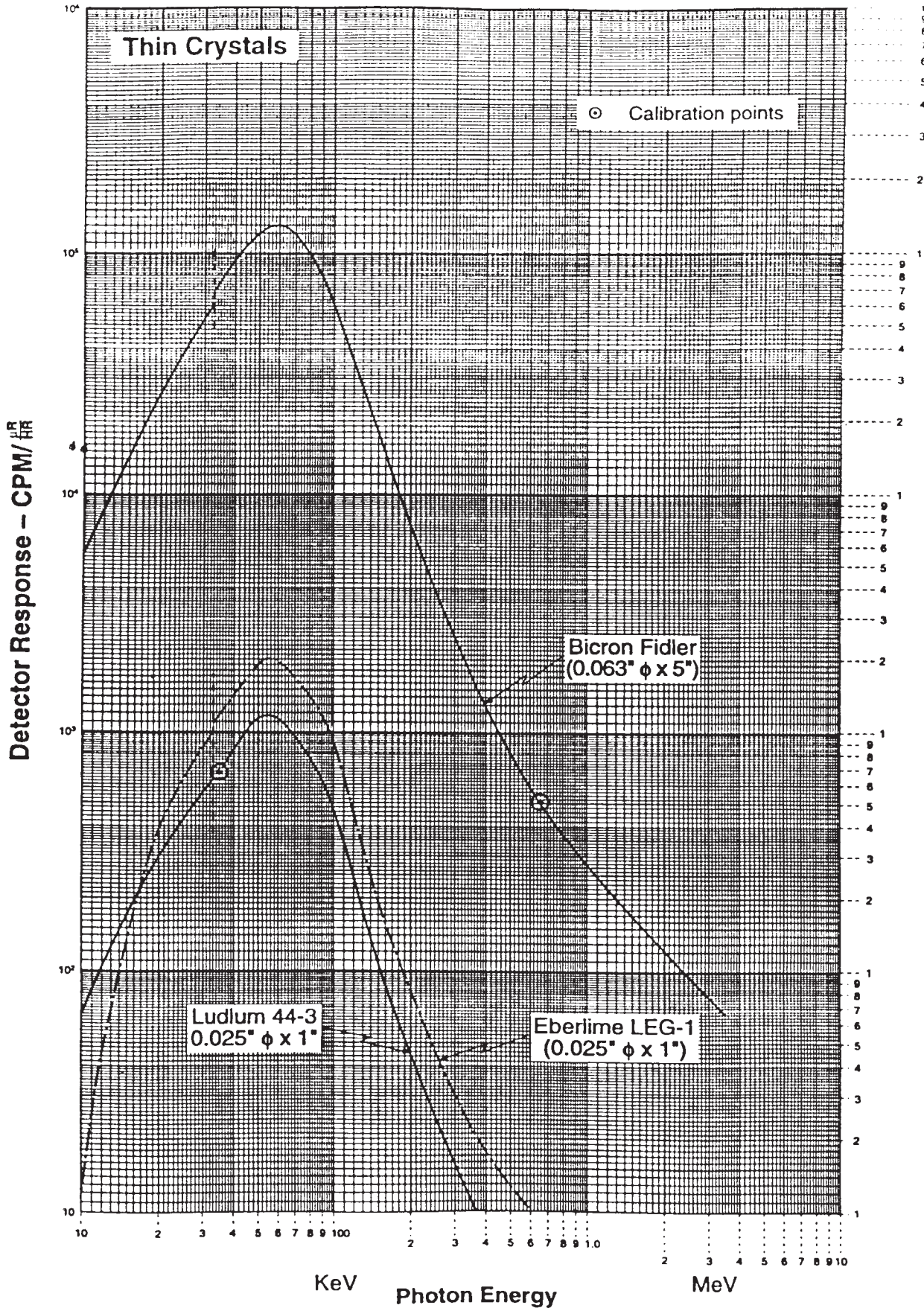

FIG. 14 Response vs Photon Energy for NaI Detectors

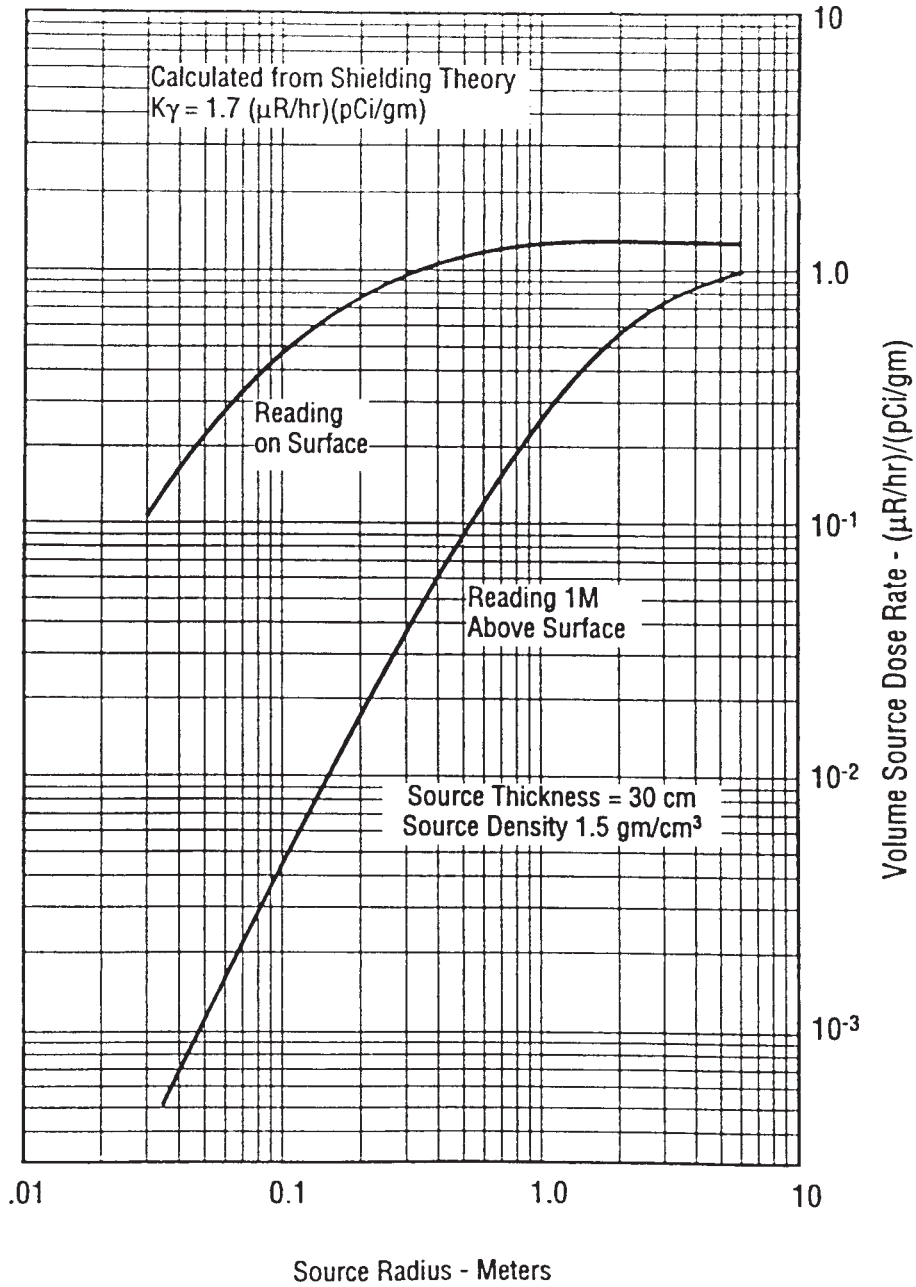

FIG. 15 Dose Rates Above Surface for Radium-226 in Soil



## REFERENCES

- (1) Regulatory Guide 1.86, Termination of Operating Licenses for Nuclear Reactors, U.S. Nuclear Regulatory Commission, Washington, DC, June 1974.
- (2) Branch Technical Position on Disposal or On-Site Storage of Thorium or Uranium Wastes from Past Operations, Federal Register Vol. 46, No. 205, Oct. 23, 1981, pp 52061-52063.
- (3) DOE Order 5400.5, Radiation Protection of the Public and the Environment, U.S. Department of Energy, Washington, DC. Feb. 8, 1990.
- (4) ASTM Standard C998-90, Standard Practice for Sampling Surface Soil for Radionuclides, Annual Book of ASTM Standards, Vol. 12.01, Philadelphia, PA, pp 515-517.
- (5) ASTM Standard C999-90, Standard Practice for Soil Sample Preparation for the Determination of Radionuclides, Annual Book of ASTM Standards, Vol. 12.01, Philadelphia, PA, pp 518-520.
- (6) ASTM Standard C1000-90, Standard Test Method for Radiochemical Determination of Uranium Isotopes in Soil by Alpha Spectrometry, Annual Book of ASTM Standards, Vol. 12.01, Philadelphia, PA, pp 521-524.
- (7) ASTM Standard C1133-89, Standard Test Method for Nondestructive Assay of Special Nuclear Material in Low Density Scrap and Waste by Segmented Passive Gamma-Ray Scanning, Annual Book of ASTM Standards, Vol. 12.01, Philadelphia, PA, pp 677-689.
- (8) NUREG/1501 (Draft). "Background as a Residual Radioactivity Criterion for Decommissioning," U.S. Nuclear Regulatory Commission, Washington, DC, August 1994.
- (9) MARSSIM (Draft), Multi-Agency Radiation Survey and Site Investigation Manual, EPA-NRC-DOE-DOD, Washington, D.C.
- (10) Borgstrom, Mark C., et al., "Detection of Small Radiation Sources: The Effect of Mode of Count-Rate Presentation, Medical Physics, Vol. 15, No. 2. March/April 1988, pp 221-223.
- (11) Currie, L. A., "Limits for Qualitative Detection and Quantitative Determination," Analytical Chemistry, Vol. 40, No. 3, March 1968, pp 586-593.
- (12) ISO/CD 11924-4, "Determination of the Lower Limits of Detection and Decision for Ionizing Radiation Measurements; Part 4: Fundamentals and Applications to Measurements by Use of Linear Scale Ratemeters without the Influence of Sample Treatment," draft standard issued for comment May 8, 1994.
- (13) Bishop, R. V., "Optimization of Detector Size and Scan Rate for Beta-Gamma Material Release Surveys," pages presented at the 1993 DOE Radiation Protection Workshop, Las Vegas, NV April 13-15, 1993.
- (14) Loevinger, Robert, PhD., "The Dosimetry of Beta Sources in Tissue - The Point Source Function," paper presented at the 40th Annual Meeting of the Radiological Society of North America, Los Angeles, CA Dec 8-10, 1954.
- (15) Walker, Edward, "Proper Selection and Application of Portable Survey Instruments for Unrestricted Release Surveys," paper presented at the 1994 International Symposium on D&D, Knoxville, TN, April 24-29, 1994.
- (16) ISO/CD 11932, "Activity Measurements of Solid Materials Considered for Recycling, Reuse, or Disposal as Non-Radioactive Waste," draft standard issued for comment April 28, 1992.
- (17) Knoll, G. F., "Radiation Detection and Measurement," 2nd ed.. J. Wiley and Sons, 1989.
- (18) NUREG-1507 (Draft), "Minimum Detectable Concentrations with Typical Radiation Survey Instruments for Various Contaminants and Field Conditions," U.S. Nuclear Regulatory Commission, Washington, DC. August 1995.
- (19) Brodsky, A. "Exact Calculation of Probabilities of False Positive and False Negatives for Low Background Counting", Health Physics 63(2):198-204, 1992.

*ASTM International takes no position respecting the validity of any patent rights asserted in connection with any item mentioned in this standard. Users of this standard are expressly advised that determination of the validity of any such patent rights, and the risk of infringement of such rights, are entirely their own responsibility.*

*This standard is subject to revision at any time by the responsible technical committee and must be reviewed every five years and if not revised, either reapproved or withdrawn. Your comments are invited either for revision of this standard or for additional standards and should be addressed to ASTM International Headquarters. Your comments will receive careful consideration at a meeting of the responsible technical committee, which you may attend. If you feel that your comments have not received a fair hearing you should make your views known to the ASTM Committee on Standards, at the address shown below.*

*This standard is copyrighted by ASTM International, 100 Barr Harbor Drive, PO Box C700, West Conshohocken, PA 19428-2959, United States. Individual reprints (single or multiple copies) of this standard may be obtained by contacting ASTM at the above address or at 610-832-9585 (phone), 610-832-9555 (fax), or service@astm.org (e-mail); or through the ASTM website (www.astm.org).*