



Designation: F 1223 – 03

Standard Test Method for Determination of Total Knee Replacement Constraint¹

This standard is issued under the fixed designation F 1223; the number immediately following the designation indicates the year of original adoption or, in the case of revision, the year of last revision. A number in parentheses indicates the year of last reappraisal. A superscript epsilon (ϵ) indicates an editorial change since the last revision or reappraisal.

1. Scope

1.1 The purpose of this test method is to establish a database of total knee replacement (TKR) motion characteristics with the intent of developing guidelines for the assignment of constraint criteria to TKR designs. (See the Rationale in Appendix X1.)

1.2 This test method covers the means by which a TKR constraint may be quantified according to motion delineated by the inherent articular design as determined while under specific loading conditions in an *in vitro* environment.

1.3 Tests deemed applicable to the constraint determination are antero-posterior draw, medio-lateral shear, rotary laxity, valgus-varus rotation, and distraction, as applicable. Also covered is the identification of geometrical parameters of the contacting surfaces which would influence this motion and the means of reporting the test results. (See Practices E 4.)

1.4 *This standard does not purport to address all of the safety concerns, if any, associated with its use. It is the responsibility of the user of this standard to establish appropriate safety and health practices and determine the applicability of regulatory limitations prior to use.*

2. Referenced Documents

2.1 ASTM Standards:

- E 4 Practices for Force Verification of Testing Machines²
- F 2083 Specification for Total Knee Prosthesis³

3. Terminology

3.1 *Definitions*—Items in this category refer to the geometrical and kinematic aspects of TKR designs as they relate to their human counterparts:

3.1.1 *anterior curvature*—a condylar design which is generally planar except for a concave—upward region anteriorly on the tibial component.

3.1.2 *anterior posterior* (AP)—any geometrical length aligned with the AP orientation.

3.1.3 *AP displacement*—the relative linear translation between components in the AP direction.

3.1.4 *AP draw load*—the force applied to the movable component with its vector aligned in the AP direction causing or intending to cause an AP displacement.

3.1.5 *biconcave*—a condylar design with pronounced AP and ML condylar radii seen as a “dish” in the tibial component or a “toroid” in the femoral component.

3.1.6 *bearing surface*—those regions of the component which are intended to contact its counterpart for load transmission.

3.1.7 *condyles*—entity designed to emulate the joint anatomy and used as a bearing surface primarily for transmission of the joint reaction force with geometrical properties which tend to govern the general kinematics of the TKR.

3.1.8 *distraction*—the separation of the femoral component(s) from the tibial component(s) in the *z*-direction.

3.1.9 *flexion angle*—the angulation of the femoral component (about an axis parallel to the *y*-axis) from the fully extended knee position to a position in which a “local” vertical axis on the component now points posteriorly.

3.1.9.1 *Discussion*—For many implants, 0° of flexion can be defined as when the undersurface of the tibial component is parallel to the femoral component surface that *in vivo* contacts the most distal surface of the femur. This technique may not be possible for some implants that are designed to have a posterior tilt of the tibial component. In these cases, the user shall specify how the 0° of flexion position was defined.

3.1.10 *hinge*—a mechanical physical coupling between femoral and tibial components which provides a singular axis about which flexion occurs.

3.1.11 *hyperextension stop*—a geometrical feature which arrests further progress of flexion angles of negative value.

3.1.12 *internal-external rotation*—the relative angulation of the moveable component about an axis parallel to the *z*-axis.

3.1.13 *joint reaction force*—the applied load whose vector is directed parallel to the *z*-axis, generally considered parallel to tibial longitudinal axis.

3.1.14 *medio-lateral* (ML)—the orientation that is aligned with the *y*-axis in the defined coordinate system.

3.1.15 *ML condylar radius*—the geometrical curvature of the component’s condyle in the frontal plane.

¹ This test method is under the jurisdiction of ASTM Committee F04 on Medical and Surgical Materials and Devices and is the direct responsibility of Subcommittee F04.22 on Arthroplasty.

Current edition approved Apr. 10, 2003. Published June 2003. Originally approved in 1989. Last previous edition approved in 2001 as F 1223 – 01.

² *Annual Book of ASTM Standards*, Vol 03.01.

³ *Annual Book of ASTM Standards*, Vol 13.01.

3.1.16 *ML dimension*—any geometrical length aligned with the ML orientation.

3.1.17 *ML displacement*—the relative linear translation between components in the ML direction.

3.1.18 *ML shear load*—the force applied to the moveable component with its vector aligned in the ML direction causing or intending to cause an ML displacement.

3.1.19 *post-in-well feature*—a TKR design which tends to influence kinematics through the coupling of a prominent eminence with a recess or housing in a mating component.

3.1.20 *rotary laxity (RL)*—degree of relative angular motion permitted of moveable component about the z-axis as governed by inherent geometry and load conditions.

3.1.21 *rotary torque*—the moment applied to the moveable component with its vector aligned to an axis parallel to the z-axis and causing or intending to cause an internal or external rotation.

3.1.22 *tibial eminence*—a raised geometrical feature separating the tibial condyles.

3.1.23 *valgus-varus constraint*—degree of relative angular motion allowed between the femoral and tibial components of post-in-well designs (or similar designs) in the coronal plane.

3.2 *Definitions of Terms Specific to This Standard:*

3.2.1 *constraint*—the relative inability of a TKR to be further displaced in a specific direction under a given set of loading conditions as dictated by the TKR’s geometrical design. This motion is limited, as defined in this test, to the available articular or bearing surfaces found on the tibial component. The actual relative motion values will be provided as an indicator of this type of constraint.

3.2.2 *coordinate system* (see Fig. 1)—a set of arbitrary cartesian coordinates affixed to the stationary component and aligned such that the origin is located at the intersection of the y and z axes.

3.2.2.1 *Discussion*—The y-axis is parallel to the ML direction, directed medially, and is coincident with the mated

components’ contact points when the knee is in the neutral position (see 7.2). The z-axis is located midway between the mated components’ contact points (or in the case of a singular contact point, located at that point) and aligned in the superior-inferior direction of the distal component. A third axis, x, mutually orthogonal to the two previous axes is directed posteriorly. For determination of contact points, see Annex A1 and Fig. 2. The contact point shall be located to a tolerance of ± 1 mm. In the case of multiple contact points on a condyle, an average location of the contact points shall be used.

3.2.3 *degrees of freedom*—although the knee joint is noted to have 6 df, or directions in which relative motion is guided (three translations: AP, ML, vertical; three angulations: flexion, internal-external rotation, valgus-varus), the coupling effects due to geometrical features reduce this number to five which are the bases of this test method: AP draw, ML shear, internal-external rotation, valgus-varus rotation, and distraction.

3.2.4 *neutral position* (see 7.2)—that position in which the TKR is at rest with no relative linear or angular displacements between components.

3.2.4.1 *Discussion*—This is design-dependent and there may be a unique neutral position at each flexion angle. It may be indicated that the femoral component, when implanted, be positioned at some angle of hyperextension as seen when the patient’s knee is fully extended; this, then becomes the neutral position for negative flexion angle tests. The neutral position

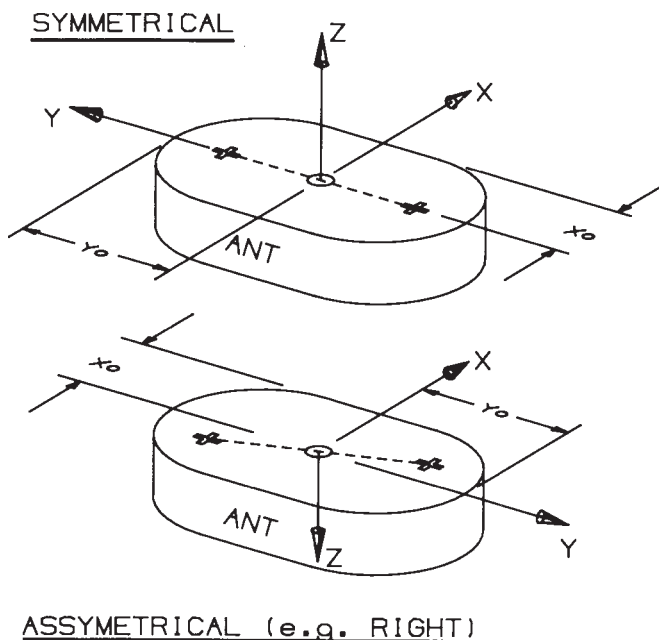
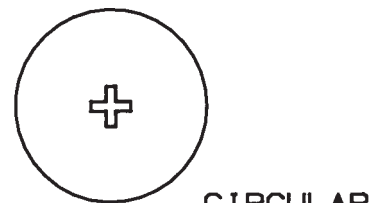

FIG. 1 Defined Coordinate System Examples



CIRCULAR



RECTANGULAR



GENERAL

CONTACT POINT (+) IS CENTROID OF CONTACT AREA

FIG. 2 Tibial Condyle Contact Point Location Examples

may be determined by either applying a compressive force of 100 N and allowing the implant to settle or by measuring the vertical position of the movable component with respect to the stationary and using the low point of the component as the neutral point. In those implants with a flat zone and no unique low point, the midpoint of the flat zone can be used as the neutral point. For those implants having a tibial component with a posterior tilt, the user may use other means to define the neutral point, but will report on how it was found.

3.2.5 *set point*—that numeric quantity assigned to an input such as a load.

3.2.6 *movable component*—that component identified either through design or test equipment attributes as providing the actual relative motion values.

3.2.6.1 *Discussion*—Depending upon the user’s fixtures and the stationary component, it can be either the tibial or femoral component.

3.2.7 *stationary component*—that component identified either through design or test equipment attributes as being at rest during that test to which actual relative motion values are referenced.

3.3 *Symbols: Parameters*—

3.3.1 *TAP*—overall AP tibial surface dimension.

3.3.2 *TML*—overall ML tibial surface dimension.

3.3.3 *x, y, z*—axes of neutral position coordinate system as defined in Annex A1.

3.3.4 *DIST*—a “yes/no” response to distraction test at the reported angle at which distraction is most likely to occur.

4. Significance and Use

4.1 This test method, when applied to available products and proposed prototypes, will attempt to provide a database of product functionality capabilities (in light of the suggested test regimens) that is hoped to aid the physician in making a more informed total knee replacement (TKR) selection.

4.2 A proper matching of TKR functional restorative capabilities and recipient’s (patient’s) needs is more likely provided for by a rational testing protocol of the implant in an effort to reveal certain device characteristics pertinent to the selection process.

4.3 The TKR product designs are varied and offer a wide range of constraint (stability). The constraint of the TKR in the *in vitro* condition is dependent on several geometrical and kinematic interactions among the implant’s components which can be identified and quantified. The degree of TKR’s kinematic interactions should correspond to the recipient’s needs as determined by the physician during clinical examination.

5. Apparatus

5.1 *General:*

5.1.1 The stationary component should be free to move only in directions parallel to the z-axis and not permitted to rotate about this axis in all but the distraction test. In the distraction test it is fully fixed.

5.1.2 The movable component shall be the displaced member when under loads specific to that test and shall be instrumented accordingly to obtain data pertinent to that test.

5.1.3 Load or torque actuators producing input vectors which tend to displace the movable component relative to the stationary component according to the guidelines of the specific tests shall be provided with a means of gradually applying the load or torque to the set point of that test.

5.1.4 Displacement sensing devices shall be arranged so as to measure relative motion between components in accordance with the prescribed coordinate system.

5.1.5 Output graphs depicting the relationship of load and displacement are required (See Fig. 3.)

5.1.6 The moveable component shall be mounted on a fixture with near zero friction or the effect of that friction must be subtracted from the applied force.

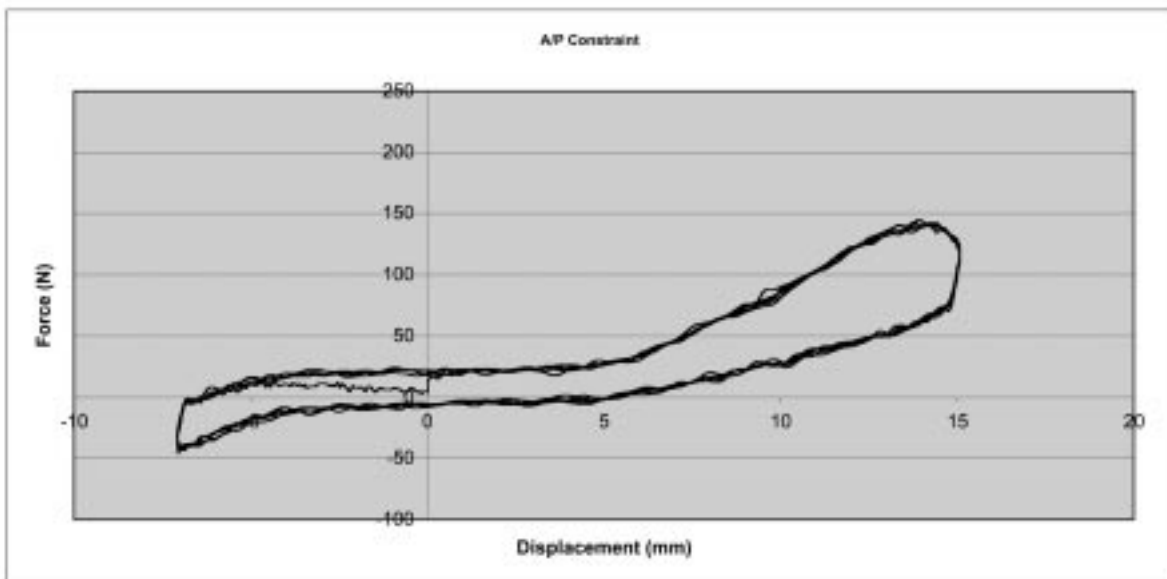

FIG. 3 Output Graph Example

5.1.7 *Tibial Tray Alignment*—The tibial tray shall be mounted to reflect the recommended amount of posterior slope, if any.

5.1.8 The femoral component alignment shall be mounted according to the manufacturer’s specifications, such that during flexion both femoral condyles are in contact with the tibial condyles.

5.2 *Antero-Posterior Draw Test*—The movable component shall be rigidly set in a fixture free to move in linear directions parallel to the *x*-axis only.

5.3 *Medio-Lateral Shear Test*—The movable component shall be rigidly set in a fixture free to move in linear directions parallel to the *y*-axis only.

5.4 *Rotary Laxity Test*—The movable component shall be rigidly set in a fixture free to move in angular displacements about an axis parallel to the *z*-axis only.

5.5 *Distraction Test:*

5.5.1 The movable component shall be rigidly set in a fixture free to move in only those directions tending to permit such distraction. Should distraction be possible at more than one angle of flexion the test should be conducted at that angle which would most likely permit the distraction.

5.5.2 The stationary component shall be rigidly set in a fixture and not permitted to move in those directions allowed to the movable component.

5.6 *Valgus-Varus Test:*

5.6.1 Install the tibial component in a fixture in which it is either completely fixed, or free to translate linearly in a medial-lateral direction (*y*-direction) and anterior-posterior direction (*x*-direction).

5.6.2 Install the femoral component in a fixture such that it is free to rotate in the coronal plane (*yz*-plane). If the tibial component is fixed, then the femoral component must be free to translate medial laterally and anterior posteriorly. The femoral component must be free to lift off of one condyle while the other condyle remains in contact.

6. Test Specimens

6.1 *TKR Specimens:*

6.1.1 The TKR should be the manufacturer’s designated “standard” or “medium” size as this is more suitable to the loading regimes encountered in the tests.

6.1.2 The implant shall be procured in its original packaging as supplied to the user by the manufacturer.

6.1.3 If the implant is not available in its package state, the condition of the device must meet all geometry and material specifications, but may contain slight surface irregularities (that is, “cosmetic rejects”) not considered influential in those regions of the device deemed critical to the specific test.

6.2 *TKR Prototype*—The implant shall be of quality as in 6.1.3.

7. Sample Measurement

7.1 *General:*

7.1.1 The constraint values refer to the relative ability of the components to be displaced under the loads applied while guided by the geometrical features inherent in the component design. These features are herein identified as being solely based on bearing surfaces, although certain designs offer

enhanced constraint (stability) due to other structures. The tibial bearing surfaces are used as a reference for relative displacement since the components should not move beyond the limits of these features, this being disarticulation.

7.2 *Neutral Position (NP)*—The neutral position is used as the initial at-rest condition prior to any test as defined in 3.2.4. It also corresponds to the measurement coordinate system which is affixed to the stationary component and aligned along anatomical planes. The location of the origin of the coordinate system is determined in Annex A1.

7.3 *Tibial Bearing Surface Dimensions:*

7.3.1 The TML and TAP reflect the medial-lateral width and antero-posterior length of the tibial tray. Typically, TML shall be the maximum width of the implant. The TAP shall be the maximum antero-posterior dimension, typically at the medial-lateral center of the implant.

7.3.2 Overall tibial surface dimensions are measured from their projection onto the coronal or *xy*-plane. Refer to Figs. 1-6, and (TAP, TML, *X_o*, and *Y_o*).

8. Conditioning

8.1 Expose the test specimens to a clean atmosphere at a temperature of 25 ± 5°C for 24 h prior to testing.

8.2 At the time of the test, the tibial bearing surface will be lightly coated with a film of silicon to reduce frictional effects. Before testing, the implant must be moved cyclically three times in the desired direction before data are acquired. These three repetitions can be performed by hand or using the method described in Section 9.

8.3 The implant shall be moved a minimum of four times in the desired test direction. The data in the last repetition shall be used for analysis.

9. Procedure

9.1 *General:*

9.1.1 Distraction and valgus-varus constraint test instructions are a special case, refer to 9.5 and 9.6.

9.1.2 Prior to installation of the tibial component, measure all relevant bearing surface dimensions as described in 7.3.

9.1.3 Install the stationary component in the apparatus such that the imaginary coordinate system attached to the stationary

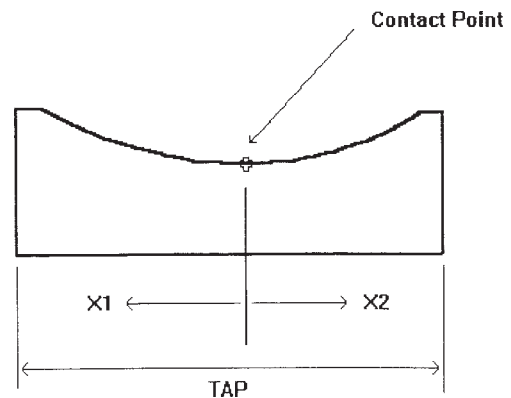

NOTE 1—Sagittal plane section view. Cut taken through the condylar contact points. Anterior is to the left.

FIG. 4 AP Dimensions and Displacement Examples

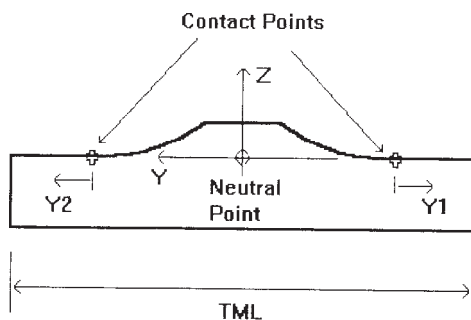

NOTE 1—Coronal plane section view. Cut taken through the condylar contact points. Medial is to the left.

FIG. 5 ML Dimensions and Displacements Example

component is aligned with that of the fixturing, that is, loading devices are aligned with their respective axes.

9.1.4 The tests shall be performed at flexion angles specified by Specification F 2083.

9.1.5 Install the movable component such that when mated to the stationary component the condylar contact points seen are the same as those used to describe the neutral position and, hence, the coordinate system for that flexion angle.

9.1.6 Null all output instrumentation.

9.1.7 Apply the joint reaction force to a set point of 710 N (160 lbf).

9.1.8 If the AP draw, ML shear, or rotary laxity tests are stopped before reaching the set point load or torque, due to possible dislocation of the components, the maximum load or torque reached will be recorded and included in the report.

9.1.9 Each test must be completed within 2 min from initiation of the AP drawer force, the ML shear force, or the torque. If the time required to complete the test is greater than 2 min, it shall be reported. However, to minimize variations in the joint reaction force, each test should not be completed in less than ten seconds.

9.1.10 If an *xy* slider is used to allow antero-posterior or medial motion, the slider friction will be measured and compensated for in the applied set point values.

9.1.11 If an implant has movable meniscal bearing inserts, they should not be constrained during each test.

9.2 AP Draw Test:

9.2.1 Apply the anteriorly directed AP draw load gradually. Stop the test when dislocation of the components is imminent, a mechanical stop prevents further motion, or if a dangerous or unrealistic situation is about to occur.

9.2.2 Record the AP displacement (in millimetres) and corresponding force (in N) during the test.

9.2.3 Remove the loads and relocate the movable component to the neutral position.

9.2.4 Repeat 9.1.6 and 9.1.7 and 9.2.1, but direct the AP load posteriorly.

9.2.5 Record the AP displacement (in millimetres) and force (in N).

9.2.6 For additional flexion angles repeat 9.1.5-9.1.7 and 9.2.1-9.2.5.

9.2.7 Alternatively, the test can be run continuously going from anterior to posterior to anterior without restarting at the neutral position.

9.3 ML Shear Test:

9.3.1 Gradually apply the ML shear load. Stop the test when dislocation of the components is imminent, a mechanical stop prevents further motion, or if a dangerous or unrealistic situation is about to occur.

9.3.2 Record the ML displacement (in millimetres) and force (in N).

9.3.3 Remove the loads and relocate the movable component to the neutral position.

9.3.4 Repeat 9.1.6 and 9.1.7 and 9.3.1, but direct the ML shear load laterally.

9.3.5 Record the ML displacement (in millimetres) and force (in N).

9.3.6 For additional flexion angles, repeat 9.1.5-9.1.7 and 9.3.1-9.3.5.

9.3.7 Alternatively, the test can be run continuously going from medial to lateral to medial without restarting at the neutral position.

9.4 Rotary Laxity Test:

9.4.1 Apply the rotary torque gradually, directed internally, until disarticulation of the components is imminent, a mechanical stop prevents further motion, a rotation of 20° is reached, or a torque of 25 N-m is reached.

9.4.2 Record the ending internal rotation (in degrees) and the torque (in N-m).

9.4.3 Remove the loads and relocate the movable component to the neutral position.

9.4.4 Repeat 9.1.5-9.1.7 and 9.4.1, but direct the rotary torque externally.

9.4.5 Record the external rotation (in degrees) and the torque (in N-m).

9.4.6 For additional flexion angles repeat 9.1.5-9.1.7 and 9.4.1-9.4.5.

9.4.7 Alternatively, the test can be run continuously going from internal to external to internal without restarting at the neutral position.

9.5 Distraction Test:

9.5.1 If distraction is deemed possible at more than one flexion angle, select that flexion angle at which distraction is most likely to occur.

9.5.2 Install the components in the apparatus such that the distraction force vector is in line with those design features normally providing the coupling for which distraction is being tested.

9.5.3 Apply the distraction force gradually to the movable component to a set point of 44.5 N.

9.5.4 If distraction occurred prior to or at the set point, report only that distraction occurred and the flexion angle for the occurrence.

9.6 Valgus-Varus Constraint Test:

9.6.1 Only those knee implant designs intended for valgus-varus constraint will be tested. Valgus angulation and varus angulation will be determined separately.

9.6.2 Position the femoral component such that the condylar contact points are the same as those used to describe the neutral position.

9.6.3 The test will be performed at flexion angles specified by Specification F 2083.

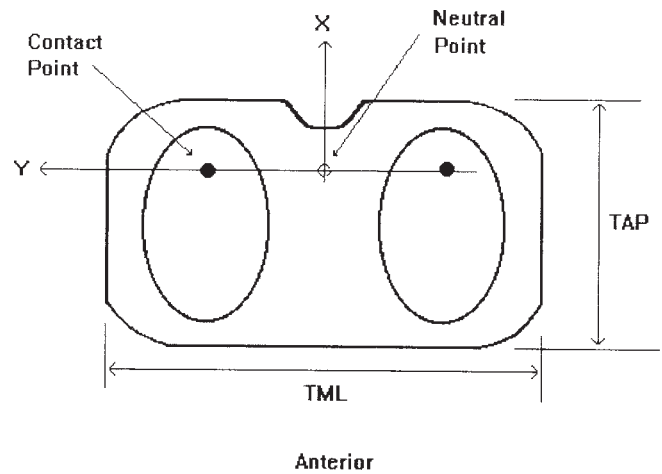
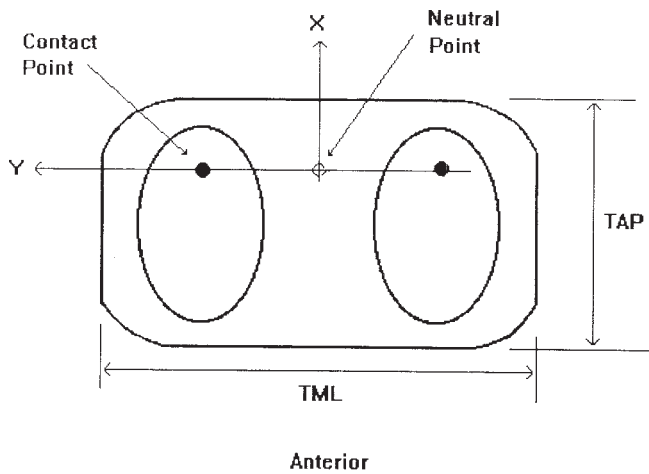

Note—Transverse plane section view. Center of rotation for rotary laxity test is about the neutral point.

Note—Transverse plane section view. Center of rotation for rotary laxity test is about the neutral point.

FIG. 6 A,B Neutral Point Determination Example

9.6.4 Apply a joint reaction force of 45 ± 1 N.

9.6.5 Measure the change in valgus-varus angle either directly with a device accurate to at least 0.1° (for example, digital protractor, tilt meter, and so forth) or indirectly by computing the angle from other measurements such as by using a LVDT.

9.6.6 Apply a valgus torque until contact between the tibial post and femoral well occurs. Measure the corresponding angle. The torque can be due to either a medial-lateral force or one in another direction that achieves the same purpose.

9.6.7 Apply a varus torque until contact between the tibial post and femoral well occurs. Measure the corresponding angle.

9.6.8 Repeat the valgus and varus loading five times.

10. Report

10.1 Product codes, lot and heat numbers, serial numbers, and special processes that might influence the test results should be noted.

10.2 Product sizing and specific dimensions relative to the performance of the tests that shall be recorded include *TAP* and *TML* (see Figs. 4-6).

10.3 Report the location (in millimetres) of each neutral position with respect to prominent landmarks on the movable component (see Fig. 1).

10.4 Report the AP, ML displacements and tibial rotation as a force/displacement or torque/rotation graph. Include the unloading portion of the test to show any hysteresis effect.

10.5 Report the valgus angulation, the varus angulation (mean and standard deviation of five trials).

10.6 Report the friction measured in the linear slider that was subtracted from the applied AP or ML force.

10.7 Report the tibial tray alignment and femoral component alignment at each tested flexion angle.

10.8 These reports should be made available to all interested parties, including the ASTM Committee F04 Task Group on Standard Specification for Cementable Total Knee Prostheses, for the purpose of assembling a database of the constraint of total knee replacements.

11. Precision and Bias

11.1 At the current time, a round-robin test is underway. Although four participants have completed the testing, additional testing is required before a statement on the precision and bias of this test method can be made.

12. Keywords

12.1 arthroplasty; constraint; joint; laxity; prosthesis; total knee replacement

ANNEX
(Mandatory Information)
A1. NEUTRAL POSITION (NP) COORDINATE SYSTEM

A1.1 The origin is located on the stationary component at the intersection of three mutually orthogonal axes which are positioned with respect to the contact point(s) of the two components when at rest at a specific flexion angle (see Fig. 6).

A1.2 The contact point(s) on the components, which may be found using a variety of visual techniques (for example, removable dye, pressure-sensitive film, fingerprint dust, vacuum grease with carbon black, or a molding material), are the geometric centers of the contact area(s) (see Fig. 2).

A1.3 Should a line connecting the two contact points be parallel to the ML direction, and perhaps to the anterior border, then this is the *y*-axis. If the line is not aligned with the ML direction, then a point midway between the contact points is chosen through which the *y*-axis will pass being aligned in the ML direction. If only one contact point exists, then the *y*-axis passes through this point. The *y*-axis is directed medially.

A1.4 The *x*-axis is perpendicular to the *y*-axis at the midpoint between the line connecting the contact points. If only one contact point exists then the *x*-axis passes through this point. It is directed posteriorly.

A1.5 The *xy*-plane is thus at the level of the contact points and is aligned with the coronal plane. The location of the origin may now be noted referencing reported landmarks particular to the design.

A1.6 The *z*-axis is perpendicular to the *xy*-plane through the origin. It is directed using right-hand rule conventions: upward for left and symmetrical TKR, downward for right TKR (see Fig. 1).

A1.7 The geometry of the TKR may cause the contact points to shift at different flexion angles resulting in unique coordinate systems and hence neutral positions. These must be reported with reference to stated plateau landmarks.

APPENDIX
(Nonmandatory Information)
X1. RATIONALE

X1.1 In clinical practice, there are significant differences among patients' requirements for total knee prostheses. These requirements will be determined by available bone stock and soft tissue capacities for stabilization. Because of these differences a method of classification of prosthetic total knee replacement (excluding patello-femoral interaction) is desirable to allow the surgeon to assess the applicability of the knee prosthesis to the particular patient problem under consideration.

X1.2 For instance, the patient with good soft tissue restraints will perhaps require a lesser constraint prosthesis, whereas the patient with major bone loss or destroyed ligamentous structures will more probably require a prosthesis with a higher degree of constraint.

X1.3 Biomechanical testing methods may take many directions depending upon the investigator or the facilities available, or both. Quite important to the standardization is the need for uniformity throughout the various testing programs. To provide comparable data from individual investigators, a standard test protocol is desired. These data, then, will provide some of the criteria for the selection of the prosthesis which will best fit the patient's needs. This test method provides quantitative data on the degree of constraint a prosthesis may provide and does not intend to contradict the three levels of constraint defined by the (Food and Drug Administration) FDA. The Specification for

Cementable Total Knee Prostheses can use these results to classify prostheses into different categories by considering the end use of the devices and the data. Note that these tests are not intended to be nor are they related to the durability or reliability of the prosthetic device. The loads that were chosen are for relative comparison of devices and are not intended to be related to any physiological loads. They are intended to test geometrical design factors without introducing viscoelastic effects or causing deformation of the implants. It has been suggested that different results would be obtained at higher compressive preloads, but it has been shown that in one mode of testing, rotary, laxity, and the amount of compressive load does not alter the relative classification order of the knee implants tested. More data will need to be examined in the future to determine whether the magnitude of the compressive preload alters the classification of total knee replacements. The extremes in the TKR's range of motion or the manner in which such is arrested or not, as the case may be, are not covered in this test method. The speed of the test has not been specified to allow the use of deadweights for the joint reaction force. Paragraphs 9.2.1, 9.3.1, and 9.4.1 simply indicate the load should be applied gradually to eliminate any displacement spikes.

X1.4 Test Method F 1223 has been revised from its original version approved in 1989 to clarify or simplify, or both, how

certain measurements are made. As a result of the round-robin testing, it was decided to not continue to require the calculation of a constraint ratio.

X1.5 In 1995, Test Method F 1223 was further revised to increase the contact point determination tolerance (3.2.2); to not require any humidity control (8.1); to allow the preliminary motions to be performed by hand or in accordance with Section 9 (8.2); to clarify the test time limits (9.1.9 and X1.3); add descriptive title in 104; and add reference to the Rationale (X1.3).

X1.6 The 2001 revision to Test Method F 1223 added a valgus-varus constraint test that may be helpful to surgeons when deciding whether an implant will be suitable for certain patients with knee collateral ligament deficiencies. Only those implants intended for valgus-varus constraint will be tested.

X1.7 The 2003 revision to Test Method F 1223 changes the vertical load and addresses issues of the linear slider friction, friction between the articulating surfaces, reporting of results, and the tibial tray angle.

ASTM International takes no position respecting the validity of any patent rights asserted in connection with any item mentioned in this standard. Users of this standard are expressly advised that determination of the validity of any such patent rights, and the risk of infringement of such rights, are entirely their own responsibility.

This standard is subject to revision at any time by the responsible technical committee and must be reviewed every five years and if not revised, either reapproved or withdrawn. Your comments are invited either for revision of this standard or for additional standards and should be addressed to ASTM International Headquarters. Your comments will receive careful consideration at a meeting of the responsible technical committee, which you may attend. If you feel that your comments have not received a fair hearing you should make your views known to the ASTM Committee on Standards, at the address shown below.

This standard is copyrighted by ASTM International, 100 Barr Harbor Drive, PO Box C700, West Conshohocken, PA 19428-2959, United States. Individual reprints (single or multiple copies) of this standard may be obtained by contacting ASTM at the above address or at 610-832-9585 (phone), 610-832-9555 (fax), or service@astm.org (e-mail); or through the ASTM website (www.astm.org).