



Standard Practice for Cyclic Fatigue Testing of Metallic Stemmed Hip Arthroplasty Femoral Components with Torsion¹

This standard is issued under the fixed designation F 1612; the number immediately following the designation indicates the year of original adoption or, in the case of revision, the year of last revision. A number in parentheses indicates the year of last reapproval. A superscript epsilon (ε) indicates an editorial change since the last revision or reapproval.

1. Scope

1.1 This practice covers a method for the fatigue testing of metallic stemmed femoral components used in hip arthroplasty. The described method is intended to be used for evaluation in comparisons of various designs and materials used for stemmed femoral components used in the arthroplasty. This practice covers procedures for the performance of fatigue tests using (as a forcing function) a periodic constant amplitude force.

1.2 This practice applies primarily to one-piece prostheses and femoral stems with modular heads, with the head in place. Such prostheses should not have an anterior-posterior A-P bow or a medial-lateral M-L bow, and they should have a nearly straight section on the distal 50 mm of the stem. This practice may require modifications to accommodate other femoral stem designs.

1.3 The values stated in SI units are to be regarded as the standard.

1.4 *This standard does not purport to address all of the safety concerns, if any, associated with its use. It is the responsibility of the user of this standard to establish appropriate safety and health practices and determine the applicability of regulatory limitations prior to use.*

2. Referenced Documents

2.1 ASTM Standards:

- E 4 Practices for Force Verification of Testing Machines²
- E 466 Practice for Constant Amplitude Axial Fatigue Tests of Metallic Materials²
- E 467 Practice for Verification of Constant Amplitude Dynamic Loads in an Axial Load Fatigue Testing Machine²
- E 468 Practice for Presentation of Constant Amplitude Fatigue Test Results for Metallic Materials²
- E 1150 Definitions of Terms Relating to Fatigue²

¹ This practice is under the jurisdiction of ASTM Committee F04 on Medical and Surgical Materials and Devices and is the direct responsibility of Subcommittee F04.22 on Arthroplasty.

Current edition approved Aug. 15, 1995. Published December 1995.

² Annual Book of ASTM Standards, Vol 03.01.

2.2 ISO Document:³

ISO 7206-3 (1988) Stem Test

3. Terminology (see Fig. 1 Fig. 2)

3.1 Definitions of Terms Specific to This Standard:

3.1.1 *cantilever plane*—a plane perpendicular to the line of load application at the level on the stem at which the stem becomes unsupported.

3.1.2 *distal stem axis*—the centerline in the A-P projection and the M-L projection of the most distal 50 mm of the stem.

3.1.3 *estimated maximum bending moment*—the maximum compressive load times the unloaded moment arm.

3.1.4 *geometric centroid (cantilever plane)*—the point in a cross-sectional area of the cantilever plane whose coordinates are the mean values of the coordinates of all of the points in the area.

3.1.5 *line of load application*—the loading axis of the test machine.

3.1.6 *R value*—the ratio of the minimum force to the maximum force,

$$R = \frac{\text{minimum force}}{\text{maximum force}}$$

3.1.7 Reference Line L1:

3.1.7.1 *distal stem axis*—the M-L centerline of the most distal 50 mm of stem in the A-P projection.

3.1.8 Reference Line L2:

3.1.8.1 *collared device*—the plane of the distal side of the collar in the A-P projection.

3.1.8.2 *collarless device*—the resection plane recommended for the device in the A-P projection.

3.1.9 *Reference Point P1*—the spherical center of the prosthesis head.

3.1.10 Reference Point P3:

3.1.10.1 *collared device*—the intersection of the principal axis of the collar (L2) with the medial surface of the stem in the A-P projection.

3.1.10.2 *collarless device*—the intersection of the resection

³ Available from American National Standards Institute, 11 W. 42nd St., 13th Floor, New York, NY 10036.

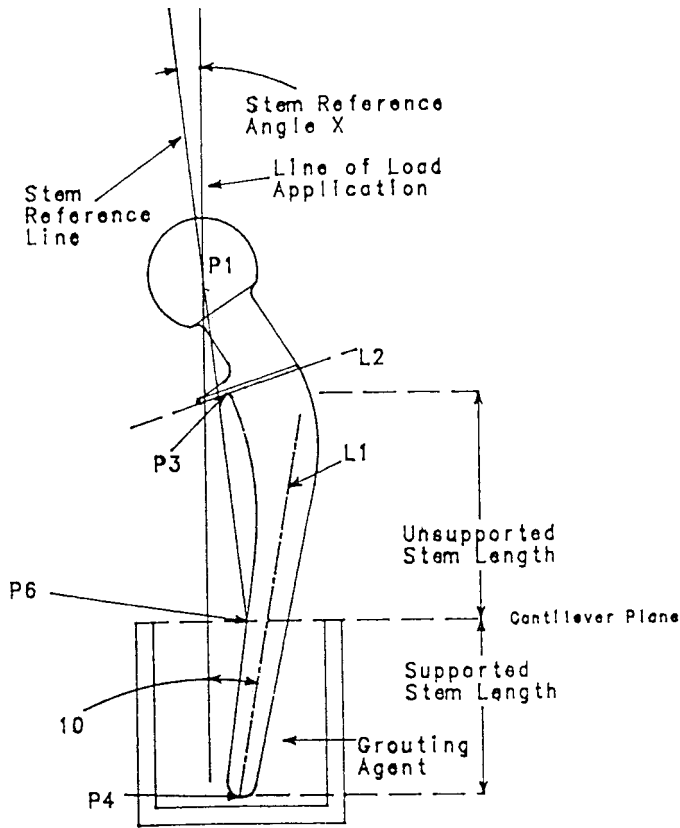

FIG. 1 1(a) Collared Device, M-L Projection

plane (L2) with the medial surface of the stem in the A-P projection.

3.1.11 *Reference Point P4*—the distal tip of the stem.

3.1.12 *Reference Point P6*⁴—the intersection of the cantilever plane with the medial surface of the stem in the A-P projection.

3.1.13 *stem reference angles*—Since the distal stem axis is obscured by the grouting agent after preparation of the test sample, the stem reference angles are to be used to measure the repeatability of the stem orientation. They may also be used to estimate the actual orientation of the distal stem to the line of load application if the stem geometry is well known.

3.1.13.1 *X (M-L)*—the angle between the stem reference line and line of load application in the M-L projection.

3.1.13.2 *X (A-P)*—the angle between the stem reference line and line of load application in the M-L and A-P projections.

3.1.14 *stem reference line*—a line passing through Reference Point P6 and the center of the prosthesis head (P1).

3.1.15 *supported stem length*—the vertical distance between the distal tip of the stem (P4) and cantilever plane.

3.1.16 *unloaded moment arm*—the vector sum of the perpendicular distance between the line of load application and geometric centroid of the stem cross section at the cantilever plane in the A-P and M-L projections.

⁴ The reference points and lines are consistent with the proposed Specification for Cementable Total Hip Prostheses with Femoral Stems. The Reference Points P2 and P5 in that specification are not relevant to this practice. Consequently, they are not used in this practice.

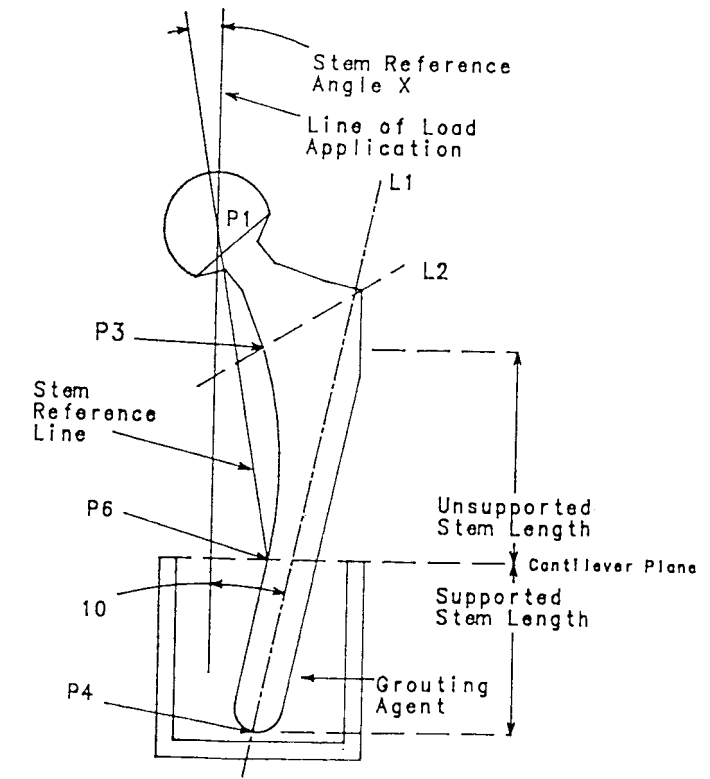

FIG. 2 1(b) Collarless Device, M-L Projection

3.1.17 *unsupported stem length*—the vertical distance between Point P3 and the cantilever plane.

4. Significance and Use

4.1 This practice can be used to describe the effects of materials, manufacturing, and design variables on the fatigue resistance of metallic stemmed femoral components subjected to cyclic loading for relatively large numbers of cycles. The recommended test assumes a worst case situation in which proximal support for the stem has been lost. It is also recognized that, for some materials, the environment has an effect on the response to cyclic loading (see section 12.7). The test environment used and rationale for the choice of that environment should be described in the test report.

4.2 It is recognized that actual in vivo loading conditions are not constant amplitude. However, sufficient information is not available to create standard load spectrums for metallic stemmed femoral components. A simple periodic constant amplitude force is accordingly recommended.

5. Purpose

5.1 In order for fatigue data on femoral stems to be useful for comparison, it must be reproducible among different laboratories. It is consequently essential that uniform procedures for testing and reporting test data be established.

6. Apparatus

6.1 The specimen shall be constrained by a suitable grouting agent within a rigid cavity. A common grouting agent used is polymethyl methacrylate (PMMA, bone cement). The minimum thickness of the grouting agent should be 1 cm. Although

bone cement is the recommended grouting agent, other material may be used, provided that it does not alter the test specimen chemically or mechanically.

6.2 The test fixtures shall be constructed so that the line of load application is in the implant A-P symmetry plane of the supported portion of the stem (Fig. 3).

6.3 The test fixtures shall be constructed so that the line of load application passes through the ball center.

6.4 A ball or roller bearing, low-friction mechanism shall be included in the loading apparatus to minimize loads not perpendicular to the cantilever plane. An example of such a mechanism is included in Appendix X2.

7. Specimen Selection

7.1 The specimen selected should have the same geometry as the final finished product, and the stem should be in the final finished condition.

7.2 The head of the prosthesis should have the same geometry and surface finish as the final finished product, unless it can be demonstrated that differences in the condition of the head have no effect on the fatigue response of the stem in this test.

7.3 The length of the neck of the prosthesis contributes to the magnitude of the maximum bending moment. The length of neck (or head offset) should be the longest possible that will be used with the femoral stem being evaluated. This will inherently maximize the maximum bending moment.

8. Equipment Characteristics

8.1 The action of the machine should be analyzed to ensure that the desired form and periodic force amplitude is maintained for the duration of the test. (see Practice E 467).

8.2 The test machine should have a load monitoring system such as the transducer mounted in line with the specimen. The test loads should be monitored continuously in the early stages of the test and periodically thereafter to ensure that the desired load profile is maintained. The varying load as determined by

suitable dynamic verification should be maintained at all times to within $\pm 2\%$ of the largest compressive force being used.

9. Procedure

9.1 *Specimen Test Orientation*—The angle between the distal stem axis and the line of load application in the M-L projection shall be $10 \pm 1^\circ$ (Fig. 1 Fig. 2)), and the angle between the distal stem axis and the line of load application in the A-P projection shall be $9 \pm 1^\circ$ (Fig. 3). An example of a method of accomplishing mounting the stem at the desired angle is given in Appendix X1.

9.2 *Specimen Mounting:*

9.2.1 Maintain the stem reference angles X (M-L) and X (A-P) within a range of $\pm 1^\circ$ over a test group.

9.2.2 Maintain the unsupported stem length within ± 2 mm.

9.2.3 Do not permit any relative motion between the prosthesis and grouting agent during hardening of the grouting agent.

9.2.4 Keep the surface of the grouting agent at the cantilever plane approximately level and perpendicular to the line of load application.

9.2.5 An example of a technique for setting a specimen in the grouting agent in the correct orientation is given in Appendix X1.

9.3 *Test Frequency*—Run all tests at a test frequency of 30 Hz or less (see section 12.8).

9.4 *R Value*—Run all tests with an R value of 10.0.⁵

9.5 Measure the unsupported stem length, stem reference angle, and moment arm for each specimen prior to testing. A possible means would be to use a shadowgraph of the A-P projection as shown in Fig. 1 Fig. 2 Fig. 3.

9.6 Measure the amount of horizontal deflection of the head in both the M-L and A-P projections in response to the periodic forcing function one time after the beginning of each test (see section 12.9).

10. Test Termination

10.1 Continue the test until the specimen fails or a predetermined number of cycles has been applied to the specimen. Specimen failure should be defined as a complete separation of the specimen, or exceeding of a deflection limit on a test machine. In reporting the results, state the criteria selected for defining specimen failure and the number of cycles shown as the predetermined runout of the test. Discard the data for a specific sample if the grouting agent fails prior to test completion.

11. Report

11.1 Report the fatigue test specimens, procedures, and results in accordance with Practice E 468.

11.2 In addition, report the following parameters: stem reference angles X (M-L) and X (A-P), unsupported stem

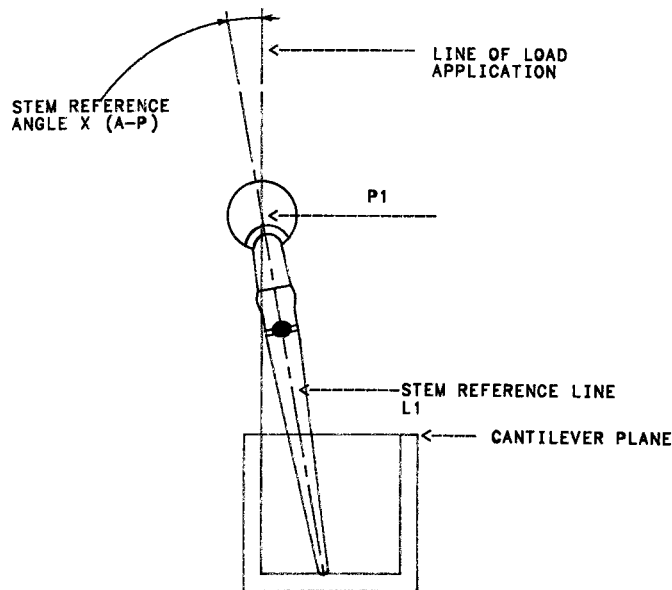

FIG. 3 Collared or Collarless Device, A-P Projection

⁵ In strict terms, since the force applied to the head is compressive, the maximum force is the largest algebraic value. The R value is consequently 10 when the negative signs cancel each other. As a numeric example, assume a test is conducted at a peak load of 3000 N (–3000). The least compressive load would be 10 % of that, or 300 N (–300). The R value would be $-3000/-300$, or 10. The R value would be 0.1 in terms of applied bending moment at the cantilever plane.

length, supported stem length, largest compressive force, R value, specimen material, cycles to failure, estimated maximum bending moment, location of fractures in relation to the cantilever plane, average dimensions of the stem cross section in the cantilever plane, grouting agent, test environment, test frequency, head/neck offset of the stem (neck length), and deflection limit used to cut off testing (see 10.1).

12. Precision and Bias

12.1 The precision and bias of this practice is being established.⁶

⁶ Test results that can be used to establish precision and bias are solicited.

APPENDIXES

(Nonmandatory Information)

X1. EXAMPLE PROSTHESIS MOUNTING PROCEDURE

X1.1 A drawing or shadowgraph of the prosthesis should be available before mounting to establish the angular relationship between the distal stem axis and stem reference angle.

X1.2 A gripping device, as illustrated in Fig. X1.1, or a ringstand and test tube holder can be used to grip the head of the subject prosthesis.

X1.3 The prosthesis is held by the head permitting the distal tip to rest on a flat surface. The angle jig illustrated in Fig. X1.2 is positioned with the distal stem in the notch. The stem is adjusted so that it is centered in the notch of the angle jig. This will orient the distal stem at approximately 10° to the line of load application. The head is now gripped firmly to maintain the angular orientation of the stem.

X1.4 The angle jig can be removed and the prosthesis mounted at the appropriate depth in an appropriate specimen holder.

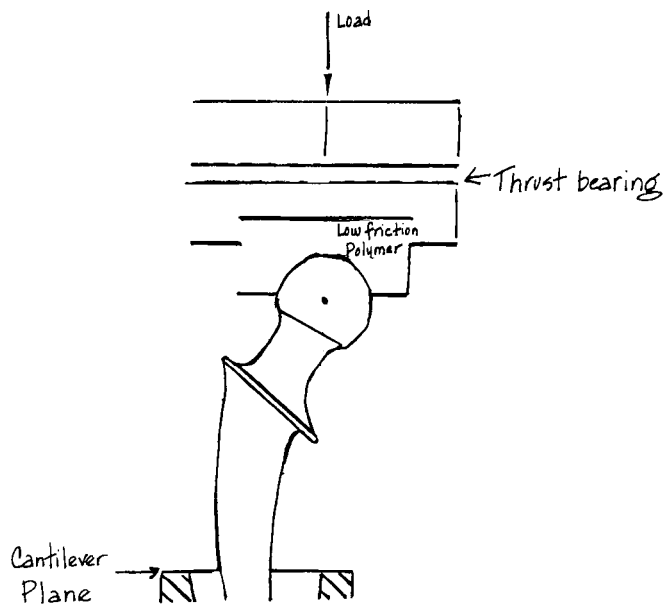

FIG. X1.1 Example of a Low-Friction Mechanism

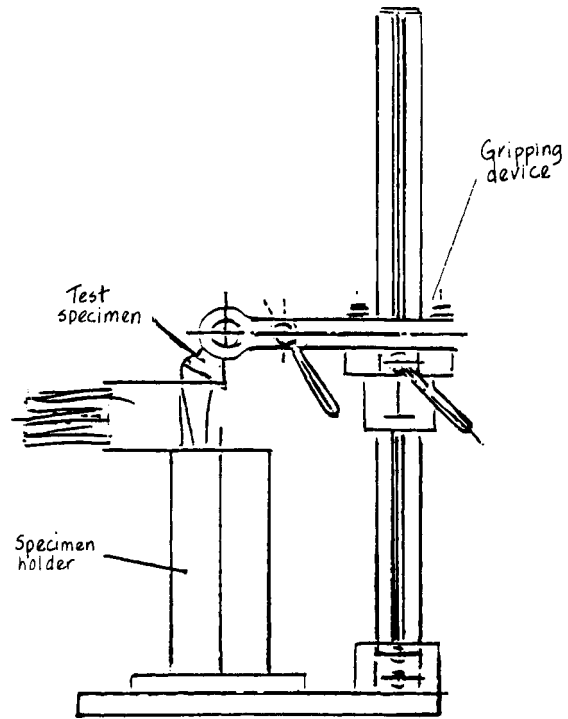

FIG. X1.2 Apparatus for Gripping the Test Specimen While Embedding it in the Correct Orientation

X1.5 Grouting material can be placed around the test prosthesis into the specimen holder and permitted to harden.

X1.6 The grip on the head of the prosthesis is released after hardening of the grouting agent, and a shadowgraph may be prepared of the profile of the test specimen and specimen holder assembly.

X1.7 A second adjustable stop may be added below the grip and adjusted to rest against the medial surface of an appropriately oriented prosthesis to facilitate repeatable mounting of the test group.

X2. RATIONALE

X2.1 The breakage of femoral stems in hip arthroplasty has occurred in clinical application. The stem design, PMMA support, quality of bone, and other features contribute to stem fracture. One recognizable mode of breakage is with the distal portion of the stem anchored firmly, while medial proximal support is lost. As the body loads are applied through the head of the prosthesis, significant stem stresses can result at the area where the cement is still firmly anchored. This simplified model was chosen for the fatigue testing of actual stems because it is believed that this proximal cement breakdown model is the primary reason behind breakage of the femoral stems. There are some problems with the proposed simplified model. The worst case assumes that proximal cement breakdown has already occurred. It does not address any features of a hip arthroplasty system that might help prevent cement breakdown or any features that aid in placing the femoral component in an optimal position with good cement support. While the latter approach is desirable, the test described can provide information on the relative fatigue strengths.

X2.2 This is a general purpose test method. It is not intended solely to be used on one specific test location on a stem but rather can estimate fatigue strengths at several different locations along the stem. There are various aspects of geometry or material features in the design of hip stems that could cause a local decrease in properties. The fatigue properties of these sections can be evaluated by changing the unsupported stem length to put the cantilever plane at or near the desired location.

X2.3 This practice attempts to model simply the orientation of the stemmed femoral component in relation to the peak loads that are applied in the human body. To accomplish this, the distal stem will have an anatomic orientation to the applied load in both the M-L and A-P plane of the prosthesis. Because of the A-P orientation, the applied load has a vector component that applies a rotation force to the main axis of the stem; this loading mode is designated "with torsion." The orientation of the applied load also causes a bending moment to be applied in two different planes. Local stresses in the prosthesis result from superposition of the stresses caused by the two bending moments and torsional component.

X2.4 It is also possible to use this practice for comparison of the relative fatigue strength of different stem designs. The unsupported stem length to select for this type of testing is difficult to select. Historically, earlier stem designs with clinical incidence of fracture fractured at several different locations along the stem. The selection of a single, unsupported stem length for all designs will have to be arbitrary. A stem performance document that references this practice will select a specific unsupported stem length. The ISO stem test document, ISO 7206-3 (1988), specifies an unsupported stem length of 80 mm. However, the ISO document defines the unsupported stem length using a simpler, but less consistent method. The ISO unsupported stem length is from the center of the head (Point P1) to the cantilever plane. The problem with this

method is that the actual stem cross section in the cantilever plane can be different, depending on the neck length of the device. The definition of unsupported stem length in this practice will test the same approximate stem section on a stem, even if the neck length is different. The Reference Line L2 can be difficult to determine on some collarless prostheses. This line corresponds to the approximate osteotomy line in the bone. It may be necessary to review the documentation from the stem manufacturer if the location of Line L2 is not obvious on the prosthesis. The stem manufacturer's literature or X-ray templates will usually include the desired location of the prosthesis relative to the osteotomy line.

X2.5 In Section 10 of this practice, there is no specification of the number of cycles for test runout. The fundamental idea behind this type of test is that the number of cycles to runout represents a limiting point beyond which the material will not fracture, no matter how many more cyclic loads are applied. This is referred to as a fatigue limit. However, most materials do not possess a true fatigue limit in real life. A compromise must consequently be made between the amount of testing (the number of test cycles) and the relationship of the test to actual device performance and device life. A typical runout point is often 10 million cycles since most of these tests are plotted and evaluated on a semilog or log-log plot. Doubling or tripling the number of test cycles to 20 or 30 million contributes only a small amount to the trend analysis on the log scale, but it doubles or triples the length of the test. In Europe, 5 million cycles has been used as a runout value for some stem tests.

X2.6 This test is a cantilever beam bending test. The load point in a cantilever beam bend test will tend to deflect in the direction of the applied load, with the amount of deflection depending on the elasticity of the test sample. The head of the prosthesis is the cantilever load point with this test. Since the direction of the load also applies a compressive force down the stem, only the vector portion of the force, perpendicular to the prosthesis' long axis, will contribute to the beam deflection. That contribution of beam bending will deflect the head to the side. This motion increases the bending moment arm effectively. This motion must be permitted. If the head is not allowed to deflect in a near frictionless manner, the portion of the test fixture that prevents the deflection is actually applying an unknown force against the head to keep it from deflecting. If the device is flexible enough, the magnitude of periodic motion of the head of the prosthesis (in the plane perpendicular to the line of load application) in response to the periodic forcing function can increase the applied maximum bending moment significantly. It may be important to measure this deflection and include it in maximum bending moment calculations.

X2.7 Any fatigue strengths as predicted by tests following the method described herein must be considered on a relative basis, that is, these tests may yield valuable information concerning the relative merits of different devices for particular applications, but they should not be used as a quantitative

indicator of the expected in vivo device lifetime.

X2.8 There is limited information in the literature regarding whether the materials used in hip arthroplasty femoral components experience a significant degradation in high-cycle fatigue initiation properties due to the presence of a physiological environment. If there is concern that the material used in the device may degrade significantly in a physiological environment, such material characteristics would be more realistically determined fatigue testing of a material test specimen in a

simulated physiological environment at rates of 1 cycle/s or less. A particular environment is not specified in this practice for these reasons, but a simulated environment is not prohibited. However, if a simulated environment is used, the test frequency should be so as to not mask the expected effects of the environment.

X2.9 Possible methods include dial gages, optical micrometers, or linear scales viewed with a strobe light to slow the apparent motion of the deflection.

The American Society for Testing and Materials takes no position respecting the validity of any patent rights asserted in connection with any item mentioned in this standard. Users of this standard are expressly advised that determination of the validity of any such patent rights, and the risk of infringement of such rights, are entirely their own responsibility.

This standard is subject to revision at any time by the responsible technical committee and must be reviewed every five years and if not revised, either reapproved or withdrawn. Your comments are invited either for revision of this standard or for additional standards and should be addressed to ASTM Headquarters. Your comments will receive careful consideration at a meeting of the responsible technical committee, which you may attend. If you feel that your comments have not received a fair hearing you should make your views known to the ASTM Committee on Standards, at the address shown below.

This standard is copyrighted by ASTM, 100 Barr Harbor Drive, PO Box C700, West Conshohocken, PA 19428-2959, United States. Individual reprints (single or multiple copies) of this standard may be obtained by contacting ASTM at the above address or at 610-832-9585 (phone), 610-832-9555 (fax), or service@astm.org (e-mail); or through the ASTM website (www.astm.org).