



## Standard Specification and Test Method for Metallic Bone Plates<sup>1</sup>

This standard is issued under the fixed designation F 382; the number immediately following the designation indicates the year of original adoption or, in the case of revision, the year of last revision. A number in parentheses indicates the year of last reapproval. A superscript epsilon ( $\epsilon$ ) indicates an editorial change since the last revision or reapproval.

### 1. Scope

1.1 This specification and test method is intended to provide a comprehensive reference for bone plates used in the surgical internal fixation of the skeletal system. The standard establishes consistent methods to classify, define the geometric characteristics, and performance characteristics of bone plates. The standard also presents a catalog of standard specifications that specify material; labeling and handling requirements; and standard test methods for measuring performance related mechanical characteristics determined to be important to the *in vivo* performance of bone plates.

1.2 It is not the intention of the standard to define levels of performance or case-specific clinical performance for bone plates, as insufficient knowledge is available to predict the consequences or their use in individual patients for specific activities of daily living. Furthermore, it is not the intention of the standard to describe or specify specific designs for bone plates used in the surgical internal fixation of the skeletal system.

1.3 This standard may not be appropriate for all types of bone plates. The user is cautioned to consider the appropriateness of the standard in view of a particular bone plate and its potential application.

1.4 This standard includes the following test methods used in determining the following bone plate mechanical performance characteristics.

1.4.1 Standard Test Method for Single Cycle Bend Testing of Metallic Bone Plates - Annex A1.

1.4.2 Standard Test Method for Determining the Bending Fatigue Properties Of Metallic Bone Plates - Annex A2.

1.5 Unless otherwise indicated, the values stated in SI units shall be regarded as the standard.

1.6 *This standard does not purport to address all of the safety concerns, if any, associated with its use. It is the responsibility of the user of this standard to establish appropriate safety and health practices and determine the applicability of regulatory limitations prior to use.*

### 2. Referenced Documents

#### 2.1 ASTM Standards:

F 67 Specification for Unalloyed Titanium for Surgical Implant Applications<sup>2</sup>

F 75 Specification for Cobalt-28 Chromium-6 Molybdenum Alloy Castings and Casting Alloy for Surgical Implants (UNS R30075)<sup>2</sup>

F 86 Practice for Surface Preparation and Marking of Metallic Surgical Implants<sup>2</sup>

F 90 Specification for Wrought Cobalt-20Chromium-15Tungsten-10Nickel Alloy for Surgical Implant Applications (UNS R56401)<sup>2</sup>

F 136 Specification for Wrought Titanium-6Aluminum-4Vanadium ELI (Extra Low Interstitial) Alloy for Surgical Implant Applications (UNS R56401)<sup>2</sup>

F 138 Specification for Wrought 18Chromium-14Nickel-2.5Molybdenum Stainless Steel Bar and Wire for Surgical Implants (UNS S31673)<sup>2</sup>

F 139 Specification for Wrought 18Chromium-14Nickel-2.5Molybdenum Stainless Steel Sheet and Strip for Surgical Implants (UNS S31673)<sup>2</sup>

F 543 Specification and Test Methods for Metallic Medical Bone Screws<sup>2</sup>

F 565 Practice for Care and Handling of Orthopedic Implants and Instruments<sup>2</sup>

F 620 Specification for Alpha Plus Beta Titanium Alloy Forgings for Surgical Implants<sup>2</sup>

F 621 Specification for Stainless Steel Forgings for Surgical Implants<sup>2</sup>

F 983 Practice for Permanent Marking of Orthopaedic Implant Components<sup>2</sup>

F 1295 Specification for Wrought Titanium-6Aluminum-7Niobium Alloy for Surgical Implant Applications<sup>2</sup>

F 1314 Wrought Nitrogen Strengthened-22Chromium-12.5Nickel-5Manganese-2.5Molybdenum Stainless Steel Bar and Wire for Surgical Implants (UNS S20910)<sup>2</sup>

F 1472 Specification for Alpha Plus Beta Titanium Alloy Forgings for Surgical Implants<sup>2</sup>

F 1713 Specification for Wrought Titanium-13Niobium-13Zirconium Alloy for Surgical Implant Applications<sup>2</sup>

<sup>1</sup> This test method is under the jurisdiction of ASTM Committee F04 on Medical and Surgical Materials and Devices and is the direct responsibility of Subcommittee F04.21 on Osteosynthesis.

Current edition approved Apr. 10, 2003. Published May 2003. Originally approved in 1973. Last previous edition approved in 1999 as F 382 – 99.

<sup>2</sup> Annual Book of ASTM Standards, Vol 13.01.

2.2 ISO Standard:<sup>3</sup>

FDIS 14602 Non-active surgical implants—Implants for Osteosynthesis particular requirements.

3. Terminology

3.1 Definitions—Geometric:

3.1.1 *auto compression*—a type of bone plate that by its design can generate a compressive force between adjacent unconnected bone fragments through the use of one or more ramped holes or another type of slot geometry. This ramp or slot geometry contacts the underside of the screw head, and induces compressive force as the screw is inserted and tightened to the bone plate.

3.1.2 *bone plate*—a metallic device with two or more holes or slot(s), or both, and a cross section that consists of at least two dimensions (width and thickness) which generally are not the same in magnitude. The device is intended to provide alignment and fixation of two or more bone sections, primarily by spanning the fracture or defect. The device is typically fixed to the bone through the use of bone screws or cerclage wire. A partial list of general types of bone plates is given in Section 4.1.

3.1.6 *contouring*—the manipulation and bending of a bone plate, either pre-operatively or intra-operatively, to match the anatomic geometry of the intended fixation location.

3.1.7 *crescent section*—a bone plate cross-section shape (perpendicular to the long axis of the bone plate) where the thickness is not constant along the section. Typically the section is thickest along the bone plate’s centerline and tapers to a smaller thickness at the bone plate’s edges (see Fig. 1b).

3.1.8 *uniform width*—referring to a bone plate where the width is constant along the bone plate’s length.

3.2 Definitions—Mechanical/Structural:

3.2.1 *bending stiffness,  $K$  (N/mm)*—of a bone plate, the maximum slope of the linear elastic portion of the load versus load-point displacement curve for a bone plate when tested according to the test method of Annex A1.

3.2.2 *bending strength (N-m)*—of a bone plate, the bending moment necessary to produce a 0.2 % offset displacement in the bone plate when tested as described in Annex A1.

3.2.3 *bending structural stiffness,  $EI$  (N-m<sup>2</sup>)*—of a bone plate, the bone plate’s normalized effective bending stiffness that takes into consideration the effects of the test setup’s

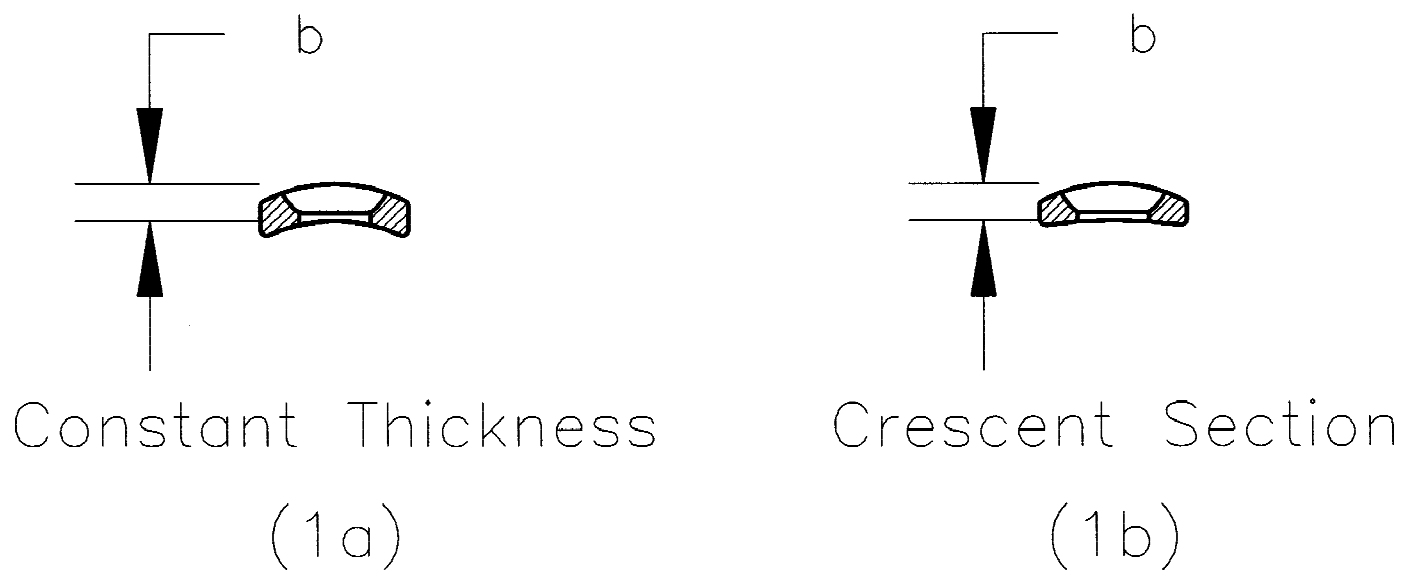

FIG. 1 Bone Plate Cross-sections

3.1.3 *bone plate length,  $L$  (mm)*—the linear dimension of the bone plate measured along the longitudinal axis as illustrated in Fig. 2.

3.1.4 *bone plate thickness,  $b$  (mm)*—the linear dimension of the bone plate measured parallel to the screw hole axis as shown in Fig. 1a, 1b, and Fig. 2. For a bone plate with a crescent section, the thickness is measured at the thickest point along the section.

3.1.5 *bone plate width,  $w$  (mm)*—the linear dimension of the bone plate measured perpendicular to both the length and thickness axes as shown in Fig. 2.

configuration when tested according to the method described in Annex A1.

3.2.4 *fatigue life,  $n$* —The number of loading cycles of a specified character that a given specimen sustains before failure of a specified nature occurs.

3.2.5 *fatigue strength at  $N$  cycles*—An estimate of the cyclic forcing parameter (for example, load, moment, torque, stress, and so on) at a given load ratio, for which 50 % of the specimens within a given sample population would be expected to survive  $N$  loading cycles.

4. Classification

4.1 Bone plates used in general orthopaedic surgery can be categorized into general types according to the following classifications.

<sup>3</sup> Available from International Standards Organization, Rue de Varembe, Case Postale 56, CH-1211, Geneva 20, Switzerland.

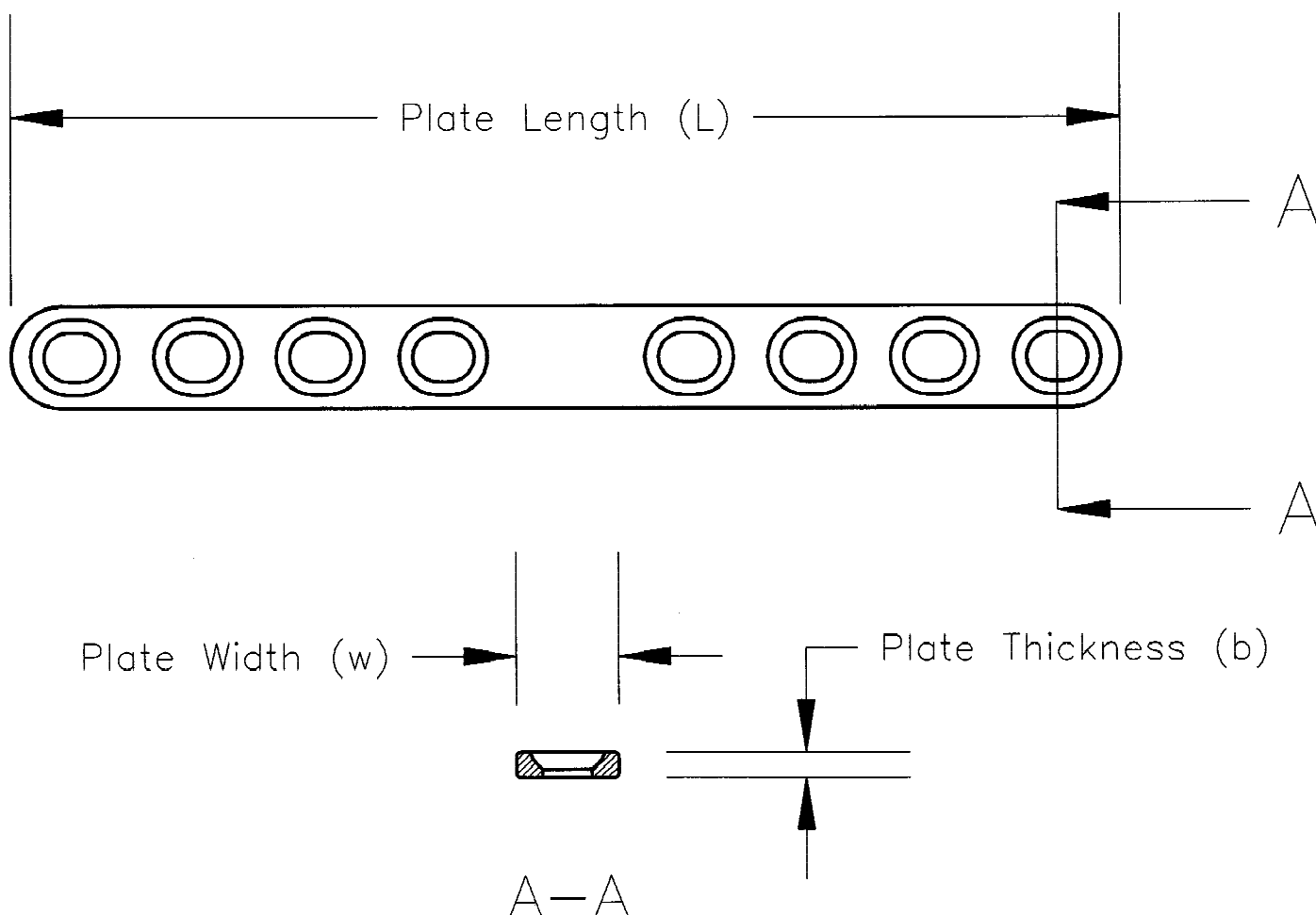

FIG. 2 Bone Plate Dimensions

4.1.1 *cloverleaf plate*—a bone plate that has one three-lobed end which contains screw holes.

4.1.2 *cobra head plate*—a bone plate that has one flared triangular or trapezoidal end which contains multiple screw holes or slots, or both. This type of bone plate is often used for hip arthrodesis.

4.1.3 *reconstruction plate*—a bone plate that does not have a uniform width, but usually has a smaller cross-section between the screw holes or slots. The reduced cross-section between screw holes/slots facilitates contouring the bone plate in several planes. Reconstruction plates are often used in fractures of the pelvis and acetabulum.

4.1.4 *straight plate*—a bone plate with uniform width and a straight longitudinal axis. Straight plates are often used for fractures of the diaphysis of long bones.

4.1.5 *tubular plate*—a bone plate whose cross-section resembles a portion of a tube, and which has a constant thickness or a crescent section. Tubular plates are often used for fractures of the smaller long bones (that is, radius, ulna, fibula).

## 5. Marking, Packaging, Labeling, and Handling

5.1 Dimensions of bone plates should be designated by the standard definitions given in Section 3.1.

5.2 Bone plates shall be marked using a method specified in accordance with either Practice F 983 or ISO 14602.

5.3 Markings on bone plates shall identify the manufacturer or distributor and shall be made away from the most highly stressed areas, where possible.

5.4 Packaging shall be adequate to protect the bone plates during shipment.

5.5 Package labeling for bone plates shall include when possible the following information:

- 5.5.1 Manufacturer and Product Name,
- 5.5.2 Catalog number,
- 5.5.3 Lot or serial number,
- 5.5.4 Material and, where applicable, its associated ASTM specification designation number,
- 5.5.5 Number of screw holes,
- 5.5.6 Bone plate width,
- 5.5.7 Bone plate length,
- 5.5.8 Bone plate thickness, and
- 5.5.9 ASTM specification designation number.

5.6 Bone plates should be cared for and handled in accordance with Practice F 565, as appropriate.

## 6. Materials

6.1 All bone plates made of materials which have an ASTM committee F04 standard designation shall meet those requirements given in the ASTM standards. A majority of materials

having ASTM specifications can be found in the list of referenced ASTM standards of Section 2.1.

6.2 Bone plates of forged Specification F 136 shall meet the requirements of specification F 620.

6.3 Bone plates of forged Specification F 138 shall meet the requirements of specification F 621.

## 7. General Requirements and Performance Considerations

7.1 *geometric considerations*—bone plates that are intended to be used with bone screws shall have design features (screw holes or slots) that conform or appropriately fit the corresponding bone screw.

7.2 *bending properties*—a critical characteristic of bone plates for orthopedic applications since the bone plate provides

the primary means of stabilizing the bone fragments. Additionally, the bending stiffness of the bone plate may directly affect the rate and ability of healing.

7.2.1 The relevant bending properties (bending stiffness, bending structural stiffness, and bending strength) shall be determined using the standard test method of Annex A1.

7.2.2 Determine the relevant bending fatigue properties according to the methods described in Annex A2.

## 8. Keywords

8.1 bend testing—surgical implants; fatigue test; bone plate; orthopedic medical devices—bone plates; surgical devices; test methods—surgical implants

## ANNEXES

### A1. STANDARD TEST METHOD FOR SINGLE CYCLE BEND TESTING OF METALLIC BONE PLATES<sup>1</sup>

#### A1.1 Scope:

A1.1.1 This test method describes methods for single cycle bend testing in order to determine intrinsic, structural properties of metallic bone plates. The test method measures the bending stiffness, bending structural stiffness, and bending strength of bone plates.

A1.1.2 This test method is intended to provide a means of mechanically characterize different bone plate designs. It is not the intention of this standard to define levels of performance for bone plates as insufficient knowledge is available to predict the consequences of the use of particular bone plate designs.

A1.1.3 *Units*—The values stated in SI units are to be regarded as standard. No other units of measurement are included in this standard.

A1.1.4 *This standard does not purport to address all of the safety concerns, if any, associated with its use. It is the responsibility of the user of this standard to establish appropriate safety and health practices and determine the applicability of regulatory limitations prior to use.*

NOTE A1.1—There is currently an ISO standard (ISO 9585—Implants for Surgery—Determination of Bending Strength and Stiffness of Bone Plates) that is similar, but not equivalent to this test method.

#### A1.2 Referenced Documents:

##### A1.2.1 ASTM Standards:

- E 4 Practices for Load Verification of Testing Machines<sup>4</sup>
- E 122 Practice for Choice of Sample Size to Estimate the Average Quality of a Lot or Process<sup>5</sup>

#### A1.3 Terminology:

##### A1.3.1 Definitions:

A1.3.1.1 *0.2 % offset displacement, q (mm)*—permanent deformation equal to 0.2 % of the center loading span distance. (point B in Fig. A1.1).

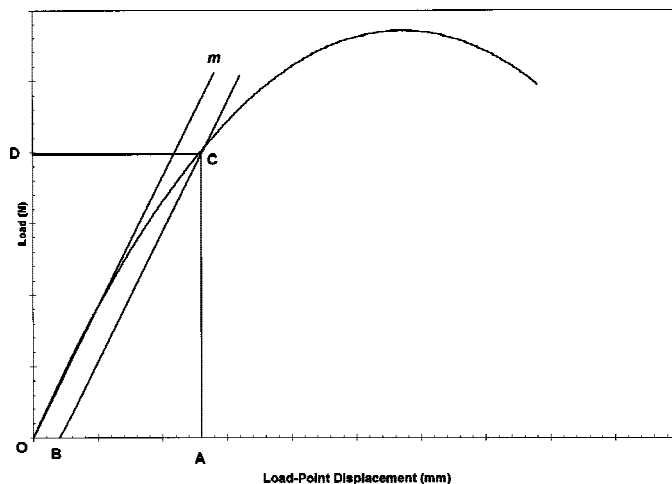

FIG. A1.1 Diagram Illustrating Methods For Determining Bending Properties of Bone Plates

A1.3.1.2 *bending strength (N-m)*—of a bone plate, the bending moment necessary to produce a 0.2 % offset displacement in the bone plate when tested as described in Section A1.8 (the bending moment corresponding to point D in Fig. A1.1.). If the bone plate fractures before the proof point is attained the bending strength shall be defined as the bending moment at fracture.

A1.3.1.3 *bending structural stiffness, (EI<sub>e</sub>) (N-m<sup>2</sup>)*—of a bone plate, the bone plate's normalized effective bending stiffness that takes into consideration the effects of the test setup's configuration. For this test method, the bending structural stiffness is determined from the single cycle bending response of the bone plate and the testing configuration.

A1.3.1.4 *bending stiffness, K (N/mm)*—of a bone plate, the maximum slope of the linear elastic portion of the load versus load-point curve when tested as described in section A1.8. (See the slope of line Om in Fig. A1.1).

A1.3.1.5 *bone plate width, w (mm)*—the width of the bone plate as shown in Fig. A1.3.

<sup>4</sup> Annual Book of ASTM Standards, Vol 03.01.

<sup>5</sup> Annual Book of ASTM Standards, Vol 14.02.

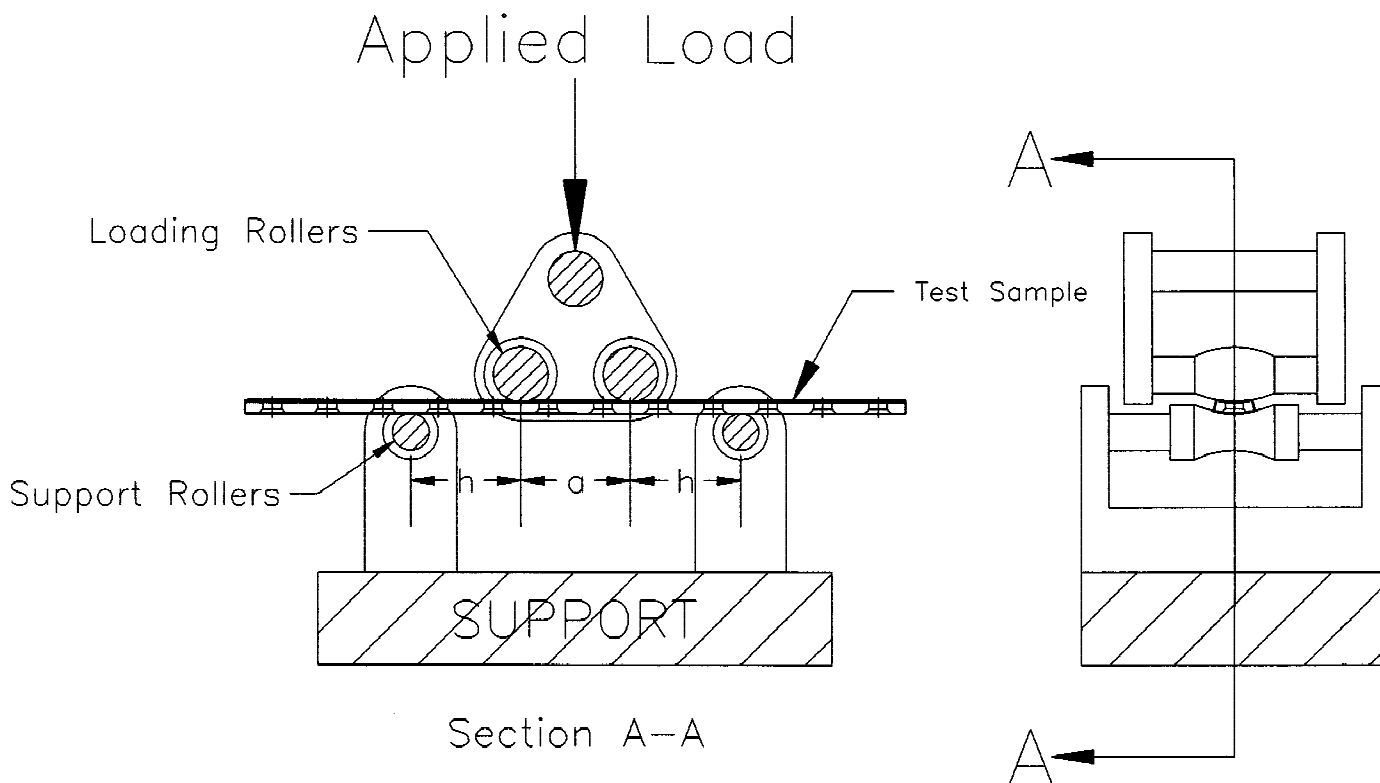

FIG. A1.2 Test Configuration

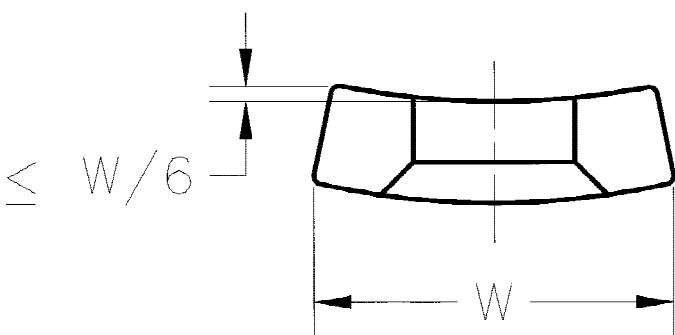

FIG. A1.3 Roller Profiling Requirements

A1.3.1.6 *center span, a (mm)*—the distance between the two loading rollers as shown in Fig. A1.2.

A1.3.1.7 *fracture load,  $F_{max}$  (N)*—the applied load at the time when the bone plate fractures.

A1.3.1.8 *loading span, h (mm)*—the distance between the loading roller and the nearest support as shown in Fig. A1.2.

A1.3.1.9 *permanent deformation (mm)*—the vertical displacement of the point of load application remaining after the applied load has been removed.

A1.3.1.10 *proof load, P (N)*—the applied load at the intersection point of line BC with the load versus load-point displacement curve. (See Fig. A1.1).

A1.3.1.11 *proof point displacement (mm)*—the load-point displacement associated with the bone plate's bending strength. (See point A in Fig. A1.1).

A1.3.1.12 *total deformation (mm)*—the vertical displacement of the point of application of the load when specified load is applied.

A1.4 *Summary of Test Method:*

A1.4.1 Bone plates are subjected to a single cycle four-point bending load. The bone plate's bending stiffness, bending structural stiffness, and bending strength are then derived from the test record generated during the test and the testing configuration.

A1.5 *Significance and Use:*

A1.5.1 This bend test is used to determine values for the mechanical response of bone plates to a specific type of bending load. The information resulting from this test method can give the surgeon some insight into the mechanical response of a given bone plate.

A1.5.2 Since the loading on the bone plate *in situ* will, in general differ from the loading configuration used in this method, the results obtained from this test method cannot be used directly to predict *in vivo* performance of the bone plate being tested. Such mechanical property data can be used to conduct relative comparisons of different bone plates designs.

A1.5.3 The bone plate's bending strength, as defined in Section A1.3.1.2, identifies the bending moment that must be applied to the bone plate in order to produce a specific amount a permanent deformation.

A1.5.4 The bending structural stiffness of the bone plate, as defined in Section A1.3.1.3, is an indicator of the bone plate's stiffness that is independent of the test configuration. Bending

structural stiffness is simply related to the bone plate's geometry and the material used in manufacturing the bone plate.

A1.5.5 This test method assumes that linear-elastic material behavior will be observed and therefore, the method is not applicable for the testing of materials that exhibit non-linear elastic behavior.

#### A1.6 Apparatus:

A1.6.1 The typical test configuration is illustrated in Fig. A1.2.

A1.6.1.1 All loads shall be applied through rollers of equal diameters within the range of 6 to 12 mm. The selected roller diameter should not be greater than the distance between two adjacent screw holes in the bone plate to be tested.

A1.6.1.2 Cylindrical rollers shall be used to test flat bone plates and bone plates of curved cross-section, in which the deviation from flatness at the center of the bone plate does not exceed  $w/6$ . Test other bone plates using rollers of profiled form corresponding to the cross-section of the bone plate to be tested (see Fig. A1.3).

A1.6.1.3 The loading and support rollers shall be positioned as follows:

A1.6.1.3.1 The loading rollers shall be positioned so that two screw holes will be located between the loading rollers. Record the center span distance.

A1.6.1.3.2 The support rollers shall be located equal distances away from the adjacent loading roller so that two screw holes will be located between the adjacent loading and support rollers. Record the distance between the loading roller and nearest support roller.

A1.6.1.3.3 The recommended testing configuration locates the loading rollers at approximately the one-third points between the supporting rollers.

A1.6.1.3.4 The applied load shall be shared equally by both loading rollers.

A1.6.1.4 Machines used for the bending test shall conform to the requirements of Practice E 4.

A1.6.2 The user is strongly encouraged to obtain bone plate test specimens of sufficient length that can be tested using the methods described in A1.6.1. However, alternative test configurations can be implemented to determine the single cycle bending properties of bone plates that do not lend themselves to the configuration of Sections A1.6.1 and A1.8.1. The user should bear in mind that the results obtained using the alternative method described below are not directly comparable to those obtained using the preferred method.

A1.6.2.1 Bone plates that do not have sufficiently long section of symmetry or do not have a section of symmetry can be attached to rigid extension segments. The rigid extension segments can be used to effectively lengthen the bone plate so that the bone plate can be tested with the four point bend test method (see Fig. A1.4 for an illustration). For these tests, the following requirements apply.

A1.6.2.1.1 The rigid extension segments shall be designed so that they do not interfere with the bone plate's deformation during the single cycle bend test.

A1.6.2.1.2 The loading rollers shall contact the rigid extension segments of the test setup during the test.

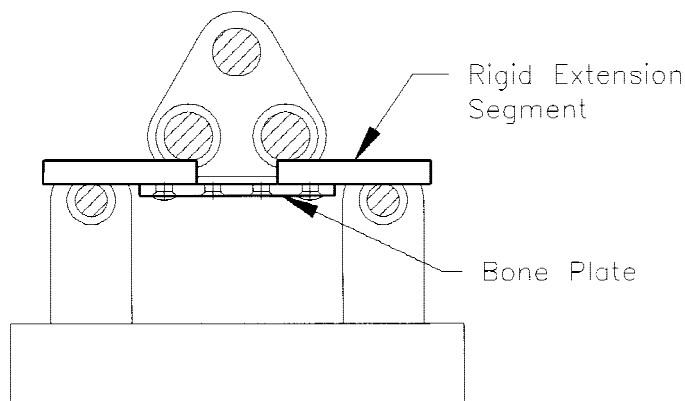

FIG. A1.4 Bone Plate with Rigid Extension Segments

A1.6.2.1.3 At the completion of the single cycle bend test, the bone plate anchor shall be examined in order to determine if the indicated permanent deformation can be related to the mechanical performance of the anchoring system.

A1.6.2.2 Alternative test configurations utilized in determining the single cycle bending properties of bone plates shall be described in the test report.

#### A1.7 Sampling:

A1.7.1 Determine sample size using the methods outlined in Practice E 122.

A1.7.2 Bone plates of different lengths but nominally identical cross sections, and made of the same material, may be used to constitute a sample.

#### A1.8 Procedure:

A1.8.1 Place the bone plate in the testing fixture and position it in accordance with the following:

A1.8.1.1 Place the bone plate so that the loading rollers are in contact with the surface of the bone plate intended to be in contact with the bone.

A1.8.1.2 If the bone plate is symmetrical, place it symmetrically with the two innermost screw holes between the loading rollers.

A1.8.1.3 If the bone plate has a central screw hole, place it with the central screw hole and one other screw hole symmetrically between the loading rollers.

A1.8.1.4 If the bone plate is asymmetrical, place it with two screw holes between the loading rollers so that the position of the fracture for which it is intended to be used shall be between the loading rollers.

A1.8.1.5 Ensure that the loading rollers are not in contact with parts of the bone plate where there is a screw hole. Wherever possible, the support rollers should not be in contact with parts of the bone plate which include a screw hole.

A1.8.1.6 Align the long axis of the bone plate so that it is perpendicular to the axes of the rollers.

A1.8.2 Apply loads of increasing magnitude, and generate a load versus load-point displacement diagram either auto-graphically or from numeric data acquired during the test.

NOTE A1.2—Displacement-controlled testing is strongly preferred over load-controlled testing. The measured deformation behavior past the yield

point can be different for load-controlled testing due to non-linear displacement rates.

A1.8.3 Determine the bending stiffness, bending structural stiffness, and bending strength for each tested bone plate according to the method that follows:

A1.8.3.1 A load versus load-point displacement curve (see Fig. A1.1) is produced either autographically or from numerical data acquired during the test.

A1.8.3.1.1 On the load versus load-point displacement diagram generated for the test, draw a best fit straight line ( $O_m$ ) through the initial (linear) portion of the load versus load-point displacement curve.

A1.8.3.1.2 Determine the bone plate's bending stiffness by calculating the slope of the line,  $O_m$ , drawn in Section 8.3.1.1.

A1.8.3.1.3 Determine the bone plate's bending structural stiffness with the following expression:

$$EI_e = \frac{(2h + 3a)Kh^2}{12} \quad (A1.1)$$

where:

- $K$  = the bending stiffness,
- $a$  = the center span distance, and
- $h$  = the loading span distance.

NOTE A1.3—Since the test method requires the inclusion of screw holes the center span region, then the bone plate's bending structural stiffness really represents and average of the  $EI_e$  over the center span region.

A1.8.3.1.4 Calculate the 0.2 % offset displacement from the expression:

$$q = 0.002 \times a \quad (A1.2)$$

where:

- $a$  = the center span distance.

A1.8.3.1.5 On the load versus load-point displacement diagram lay off  $OB$  equal to  $q$ . Then draw line  $BC$  parallel to  $O_m$ .

A1.8.3.1.6 Locate the proof load at the intersection point of line  $BC$  with the load versus load-point displacement curve.

A1.8.3.1.7 Calculate the bending strength of the bone plate from the expression:

$$\text{bending strength} = \frac{(Ph)}{2} \quad (A1.3)$$

where:

- $P$  = the proof load, and
- $h$  = the loading span distance.

A1.8.3.1.8 If the bone plate fractures prior to the load versus load-point displacement curve intersects the offset line  $BC$ , calculate the bending strength from the expression:

$$\text{bending strength} = \frac{F_{\max} \times h}{2} \quad (A1.4)$$

where:

- $F_{\max}$  = the fracture load, and
- $h$  = the loading span distance.

NOTE A1.4—It should be noted that these bending strength equations are only valid while the bone plate under test is exhibiting linear elastic behavior. The user is cautioned of this fact since this method may produce bending strength results that may not necessarily be equal to the corresponding theoretical calculations.

### A1.9 Report:

A1.9.1 Report the following information:

A1.9.1.1 Adequate description of the test material, including the number of bone plates tested,

A1.9.1.2 Adequate description of the test configuration,

A1.9.1.2.1 The center span and loading span dimensions ( $h$  and  $a$ ),

A1.9.1.3 The 0.2 % offset displacement,  $q$ , used to determine the bending strength,

A1.9.1.4 Mean and standard deviations of the bending stiffness values for the set of bone plates tested,

A1.9.1.5 Mean and standard deviations of the bending structural stiffness values for the set of bone plates tested,

A1.9.1.6 Mean and standard deviation of the bending strength values for the set of bone plates tested, and

A1.9.1.6.1 Number of bone plates fractured during the test.

A1.9.1.7 The method (either displacement or load) and rate utilized for controlling the test.

### A1.10 Precision and Bias:

A1.10.1 Precision—Data establishing the precision of the test method have not yet been obtained.

A1.10.2 Bias—No statement of bias can be made, since no acceptable reference values are available, nor can they be obtained since this test is a destructive test.

## A2. STANDARD TEST METHOD FOR DETERMINING THE BENDING FATIGUE PROPERTIES OF METALLIC BONE PLATES

### A2.1 Scope

A2.1.1 This test method describes methods for bending fatigue testing in order to determine intrinsic, metallic bone plate structural properties. The test method may be used to determine the fatigue life at a specific or over a range of maximum bending moment levels, or to estimate the fatigue strength for a specified number of fatigue cycles of a bone plate.

A2.1.2 This test method is intended to provide a means to mechanically characterize different bone plate designs. It is not the intention of this standard to define bone plate performance

levels since insufficient knowledge is available to predict the consequences of the use of a particular bone plate design.

A2.1.3 Units—The values stated in SI units are to be regarded as standard. No other units of measurement are included in this standard.

A2.1.4 *This standard does not purport to address all of the safety concerns, if any, associated with its use. It is the responsibility of the user of this standard to establish appropriate safety and health practices and to determine the applicability of regulatory limitations prior to use.*

NOTE A2.1—There is currently no ISO standard that is similar or

equivalent to this test method.

## A2.2 Referenced Documents

### A2.2.1 ASTM Standards:

- E 4 Practices for Load Verification of Testing Machines<sup>4</sup>
- E 467 Standard Practice for Verification of Constant Amplitude Dynamic Forces in an Axial Fatigue Testing System<sup>4</sup>
- E 1823 Standard Terminology Relating to Fatigue and Fracture Testing<sup>4</sup>
- E 1942 Standard Guide for Evaluating Data Acquisition Systems Used in Cyclic Fatigue and Fracture Mechanics Testing<sup>4</sup>
- F 565 Practice for Care and Handling of Orthopedic Implants and Instruments<sup>2</sup>

## A2.3 Terminology

A2.3.1 *Definitions: Unless otherwise defined in this test method, the terminology related to fatigue testing that is used in this test method will be in accordance to the definitions of ASTM E 1823.*

A2.3.1.1 *M-N diagram*—A plot of maximum moment versus the number of cycles to a specified failure point.

A2.3.1.2 *maximum moment*—The applied bending moment having the highest algebraic value during the loading cycle. A moment that generates a tensile stress on the surface of the bone plate specimen that contacts the outer support rollers (as shown in Fig. A2.1) is considered positive. Correspondingly, a moment that generates a compressive stress is considered negative.

A2.3.1.3 *median fatigue strength at 10<sup>6</sup> cycles*—An estimate of the maximum moment at which 50 % of the specimens of a given sample population would be expected to survive 10<sup>6</sup> loading cycles at a given R-ratio.

A2.3.1.4 *minimum moment*—The applied bending moment having the lowest algebraic value during the loading cycle. A moment that generates a tensile stress on the surface of the bone plate specimen that contacts the outer support rollers (as shown in Fig. A2.1) is considered positive. Correspondingly, a moment that generates a compressive stress is considered negative.

A2.3.1.5 *R-ratio*—The algebraic ratio relating the minimum and maximum values of the loading parameters of a fatigue cycle. For the purposes of this test method the R-ratio is defined as:

$$R = \frac{\text{Minimum Moment}}{\text{Maximum Moment}} \quad (\text{A2.1})$$

A2.3.1.6 *runout*—A predetermined number of cycles at which the testing on a particular specimen stopped, and no further testing on that specimen will be performed. When the intent of the fatigue test program is to determine the fatigue strength at N cycles, the runout is usually specified as N cycles.

## A2.4 Summary of Test Method

A2.4.1 A bone plate is placed in a four point bending fixture and oriented in such a way so that the bone plate's section that would normally bridge the fracture site is subjected to a uniform bending moment along the length of the section length. The bone plate is subjected to a constant frequency sinusoidal cyclic load waveform in four-point bending situation. The fatigue loading is continued until the specimen fails, a limit is reached which is indicative of failure, or the runout cycle count is reached.

A2.4.2 The data generated from a series of test samples is compiled and presented in a manner that is consistent with the goals of the study. The results can either be presented in a semi-log M-N diagram that will characterize the general fatigue behavior of the bone plate over a range of applied bending moments or simply the fatigue strength determined at 10<sup>6</sup> cycles.

## A2.5 Significance and Use

A2.5.1 The test method establishes a uniform four-point bending fatigue test to characterize and compare the fatigue performance of different bone plate designs. This test method may be used to determine a bone plate's fatigue life at either a specific or over a range of maximum bending moment conditions. Additionally, the test method may be alternatively used to estimate a bone plate's fatigue strength for a specified number of fatigue cycles.

A2.5.2 The test method utilizes a simplified bone plate load model that may not be exactly representative of the in-situ loading configuration. The user should note that the test results generated by this test method can not be used to directly predict the *in vivo* performance of the bone plate being tested. The data generated from this test method can be used to conduct relative comparisons of different bone plate designs.

A2.5.3 This test method may not be appropriate for all types of implant applications. The user is cautioned to consider the appropriateness of the method in view of the devices being tested and their potential application.

A2.5.4 This test method assumes that the bone plate is manufactured from a material that exhibits linear-elastic material behavior. Therefore, the method is not applicable for testing bone plates made from materials that exhibit non-linear elastic behavior.

A2.5.5 This test method is restricted to the testing of bone plates within the materials' linear-elastic range. Therefore, the test method is not applicable for testing bone plates under conditions that would approach or exceed the bending strength of the bone plate being tested.

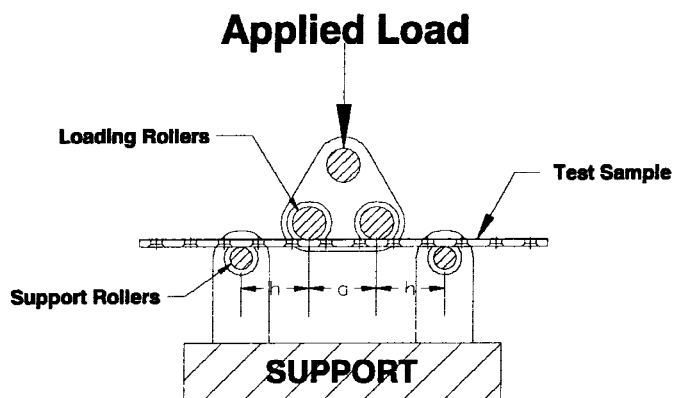

FIG. A2.1 Test Configuration



## A2.6 Apparatus

A2.6.1 Test machines used for the bending fatigue test shall conform to the requirements of Practice E 4 and E 467.

A2.6.2 The suitability of any data acquisition systems used in monitoring the progress of these tests should be evaluated in accordance to the guidelines of Guide E 1942.

A2.6.3 The typical four-point bend test configuration employed for this test is illustrated in Fig. A2.1.

A2.6.3.1 The test fixture is configured in accordance to the requirements of either section A1.6.1 or A1.6.2 of Annex A1 of this standard.

A2.6.3.2 The test fixture employed should provide a means to prevent the expulsion of the test specimen during the fatigue test. Whatever means is selected, the specimen must be free to bend in response to the applied load and shall not affect the loading situation generated in the test specimen.

A2.6.4 A cycle counter is required that is capable of counting the cumulative number of loading cycles that are applied to the specimen during the course of the fatigue test.

A2.6.5 When required, a limit detector that is capable of sensing when a test parameter (for example, load, actuator displacement, dc error, and so on) reaches a limiting value and produces a signal or action that terminates the test.

## A2.7 Test Specimens and Sampling

A2.7.1 All test components shall be representative of implant quality products with regard to material, cross-section, surface finish, markings, and manufacturing processes. Any deviation from this requirement must be noted in the final report.

A2.7.2 Per Practice F 565, bone plates that have been either implanted or contoured (reshaped) for implantation are not suitable for this test method and shall be excluded from the sample.

A2.7.3 Bone plates of different lengths but nominally identical cross sections, and made of the same material, may be used to constitute a sample.

A2.7.4 *M-N Diagram Testing*: The minimum sample size necessary for reporting the fatigue life of a given bone plate at a given maximum bending moment condition is three. A rudimentary M-N diagram with a corresponding fatigue curve would require three replicate tests at three load levels. Under ideal conditions, conduct five replicate tests at each of five maximum bending moment levels in order to enhance the statistical significance of the resulting information.

A2.7.5 *Fatigue Strength Testing*: No minimum sample size can be identified for this testing method since the total number of data points needed to make such a determination is dependent upon the methodology used and many other related factors. The user should be aware that such a study may require approximately twenty test specimens in order to generate statistically meaningful results.

## A2.8 Procedure

A2.8.1 Prior to testing, the load level(s) for testing must be determined. To evaluate the fatigue performance of a bone plate, the user has several methodologies at their disposal whose selection is based upon the output goals of the study. Two recommended methods are as follows.

A2.8.1.1 *M-N Diagram*: The user may test a given bone plate design over a range of maximum bending moment levels to characterize the general fatigue behavior trend of the device. The user's experience is the best guide that can be used for determining the initial loading conditions. In the absence of such experience, the best recommendation would be to use initial fatigue loads corresponding to 75, 50, and 25 % of the bending strength determined in accordance to this standard's Annex A1 test method. The applied moment and the cycle to test termination data are then plotted on a semi-log M-N diagram. A curve fit may be appropriately applied to the data to develop an M-N curve.

A2.8.1.2 *Fatigue Strength Determination*: The user may also test a given bone plate design in order to determine the fatigue strength at a given number of fatigue cycles. This method recommends that the fatigue strength be determined at a 1 million loading cycles (see rationale in Appendix X3). The maximum difference between the load levels used for the fatigue strength determination shall be no greater than 10 % of the bending strength determined in accordance to this standard's Annex A1 test method. Acceptable methods which can be employed to determine the bone plate's fatigue strength include the up and down method and a modified up and down method.<sup>6,7</sup>

A2.8.2 Place the bone plate in the testing fixture and position it in accordance with the following:

A2.8.2.1 Place the bone plate so that the loading rollers are in contact with the surface of the bone plate intended to be in contact with the bone.

A2.8.2.2 If the bone plate is symmetrical, place it symmetrically with the two innermost screw holes between the loading rollers.

A2.8.2.3 If the bone plate has a central screw hole, place it with the central screw hole and one other screw hole symmetrically between the loading rollers.

A2.8.2.4 If the bone plate is asymmetrical (as in the case with most specialty plates), place it with two screw holes between the loading rollers so that the position of the fracture for which it is intended to be used is located between the loading rollers.

A2.8.2.5 Ensure that the loading rollers are not in contact with plate sections that contain a screw hole. If it is not possible to meet this requirement with the bone plate design being tested, then the alternative configuration recommended in section A1.6.2 of Annex A1 of this standard should be used for the fatigue test.

A2.8.2.6 Align the long axis of the bone plate so that it is perpendicular to the axes of the rollers.

A2.8.3 Ensure that the applied load is equally shared between the test specimen loading points. The magnitude of the applied load is determined from the following expression.

<sup>6</sup> Little, R. E., and Jebe, E. H.: *Manual on Statistical Planning and Analysis for Fatigue Experiments*, STP 588, American Society of Testing and Materials, 100 Barr Harbor Drive, West Conshohocken, PA, 19428, 1975.

<sup>7</sup> Little, R. E., "Optimal Stress Amplitude Selection in Estimating Median Fatigue Limits Using Small Samples", *J. of Testing and Evaluation*, ASTM, 1990, pp. 115-122.

$$P = \frac{2M}{h} \quad (\text{A2.2})$$

Where M is the maximum moment and h is the loading span distance (see Fig. A2.1).

A2.8.4 Load the test specimen with the test system in load control using an appropriate waveform so that the resultant time dependent bending moment generated in the test specimen is cyclic and sinusoidal in nature. Select a cyclic frequency for the tests that will not produce strain sensitive affects in the bone plate's material. Typically, a cyclic frequency of 5 Hz is more than adequate for completing the test in a timely manner and will still not affect the bone plate's material.

A2.8.5 The recommended R-ratio is 0.1. Any deviations from this should be reported and justified in the final report.

A2.8.6 The cycle counter shall record the cumulative number of cycles applied to the test specimen, and the appropriate limits should be set to indicate specimen failure or deviations, or both, from the intended load parameters.

A2.8.7 Testing shall continue until the specimen breaks, a limit is reached which terminates the test, or the total cycle count reaches the runout limit.

## A2.9 Calculation and Interpretation of Results

A2.9.1 Record the results of each test including the maximum moment, cycle count at test termination, and the failure location and failure mode, if applicable.

A2.9.2 If the goal of the study is to generate an M-N diagram, then the maximum moment and cycles to test termination data is plotted on a semi-log graph. Various techniques may be used to estimate the mean or median fatigue lives, statistical differences between groups, curve fits to the fatigue data, probability of survival curves, etc.<sup>8,9</sup>

<sup>8</sup> Conway, J. B., and Sjodahl, L. H.: *Analysis and Representation of Fatigue Data*, ASM International, Materials Park, OH, 1991.

<sup>9</sup> Collins, J. A.: *Failure of Materials in Mechanical Design*, John Wiley and Sons, New York, NY, 1981.

A2.9.3 If the goal of the study is to determine the fatigue strength at 10<sup>6</sup> cycles, it is recommended that the fatigue strength be determined as the median fatigue limit (50 % probability of survival), using acceptable techniques.<sup>6,7</sup>

## A2.10 Report

A2.10.1 The test report will include the following information:

A2.10.1.1 Manufacturer of the bone plate specimen.

A2.10.1.2 The bone plate description and catalog number (if applicable).

A2.10.1.3 The bone plate material including applicable ASTM or ISO specifications.

A2.10.1.4 Deviations from normal implant product.

A2.10.1.5 The center and loading span dimensions (h and a).

A2.10.1.6 The loading roller diameters and profile.

A2.10.1.7 R-ratio.

A2.10.1.8 Test frequency.

A2.10.1.9 Description of the test environment.

A2.10.1.10 Deviations from recommended test method.

A2.10.1.11 Tabular listing that summarizes the maximum moment and the resulting cycles to test termination data.

A2.10.1.12 A description of the failure mode and failure location for each specimen which failed.

A2.10.1.13 If appropriate, a semi-log plot of the M-N diagram is generated. Include descriptions of any analytical or statistical techniques used when interpreting the fatigue data.

A2.10.1.14 If appropriate, an estimate of the fatigue strength should be reported. Include descriptions of any analytical or statistical techniques used for determining the fatigue strength.

## A2.11 Precision and Bias

A2.11.1 *Precision*—Data establishing the precision of the test method have not yet been obtained.

A2.11.2 *Bias*—No statement of bias can be made, since no acceptable reference values are available, nor can they be obtained since this test is a destructive test.

# APPENDIXES

## (Nonmandatory Information)

### XI. RATIONALE FOR SPECIFICATION

X1.1 This specification is intended to provide useful and consistent information related to the terminology, performance, application of test methods, and the application of bone plates used for maintenance of alignment and fixation during the bone healing process. Bone plate geometrical definitions, classification and terminology; material specifications; and performance definitions are provided.

X1.2 The orthopaedic surgeon should be able to select the device that they feel is appropriate for the indication. In order to do this, the surgeon must have confidence that the device's designation and sizing has a specific, known meaning that is

quantifiable and reliable regardless of the manufacturer or design. The mechanical behavior and material properties must also be described in a reliable, known manner which is irrespective of the manufacturer or design. In order to accomplish this uniformity of designations, the terminology, mechanical properties, material properties must be standardized.

X1.3 The subcommittee's goal is to produce a single standard identifying all pertinent information, requirements, and test methods for orthopedic bone plates. The first step in achieving this goal was to combine the current versions of F 382 and F 786. This revision of F 382 completes this first

step. Additional subcommittee goals include the development of a bending fatigue and torsion test methods.

## **X2. RATIONALE FOR ANNEX A1**

X2.1 This test method is designed to measure the mechanical properties of bone plates subjected to bending, which is the most common type of loading encountered *in vivo*. This test method addresses itself to properties of the device rather than the material from which the bone plate is made. A four-plate loading is specified since it produces a constant moment over the central span.

X2.2 The key quantities that are assessed (bending stiffness, bending structural stiffness, and bending strength) provide the user information on the bone plate's strength and stiffness.

X2.3 The previous version of this test method included an assessment of the bone plate's ductile behavior. Although this information is useful to the user, the supporting information needed to conduct this evaluation was not available. Therefore, the bone plate's ductile behavior evaluation has been eliminated from the test method.

X2.4 The offset displacement criteria used to determine the bone plate's bending strength has been reduced from 2 % to 0.2 % in the standard's current version. This was done for two reasons; (1) to establish a bending strength criteria that was minimally influenced by nonelastic bending of the bone plate, and (2) to make the test method consistent with the previous version of the F 382 standard test method. In the previous version of the standard the center span length was set at 1.57

inches with an offset displacement criteria of 0.004 in. (approximately 0.2 % of the center span length). The use of a 2 % offset displacement criteria would result in nearly eight times as much permanent deformation to occur prior to establishing the bone plate's yield point. One typically chooses an offset that is small enough so that the elastic limit has just been reached, but large enough so that any slippage or singular behavior at the elastic limit is avoided (0.1 % and 0.2 % for the ASTM tensile test). The use of the 2 % offset displacement criteria would result in the determination of the bone plate's bending strength that has little meaning since it is located well into the plastic region. Therefore, the adoption of the 0.2 % offset criteria will satisfy both requirements.

X2.5 The test method has been adapted to accommodate the testing of smaller bone plates and/or plates that do not have enough screw holes to meet the requirements of Sections A1.6.1 and A1.8.1. In order to accommodate these tests, the option to add rigid extension segments to the bone plate being tested is allowed (see Section A1.6.2). These extension segments effectively lengthen the bone plate so that the four point bend test configuration can be used to impart a nearly constant bending moment along the section of the bone plate located in the center span of the test setup. This is the only feasible means to test bone plates that have less than six optimally located screw holes.

## **X3. RATIONALE FOR ANNEX A2**

X3.1 Bone plate fatigue properties are an important factor when considering the surgical treatment of skeletal fractures. The bone plate may be subjected to a significant number of repetitive stress cycles during the healing process. In some situations, the bone plate may be expected to experience these conditions for several weeks until the bone healing process progresses adequately so that the bone can provide mechanical support which will reduce the stresses in the bone plate. Therefore, it is important for the surgeon to have some means to judge the fatigue performance of a given bone plate.

X3.2 Since the time frame, number of loading cycles and loading conditions are uncontrollable and unpredictable, there is no acceptable limit which can be set for the bending moment or number of cycles of load which the bone plate should withstand in any given case.

X3.3 One of the objectives of this test method is to provide a consistent methodology for determining an estimate of the bone plate fatigue strength at  $10^6$  cycles for comparative purposes. Bone plates are classified as temporary skeletal fixation devices since fractures and skeletal deformity corrections are generally resolved within 2-3 months (approximately 150 000 to 250 000 cycles). Even though the test method's recommendation of one million cycles for estimating the fatigue strength has been arbitrarily chosen, it still can be considered conservative since no bone plate in clinical service would normally be expected to withstand  $10^6$  high stress loading cycles.

X3.4 The reporting of cyclic bending fatigue strength and/or fatigue life using this standard testing technique are only suitable for comparative evaluations between devices of different sizes, designs, and materials.

 **F 382 – 99 (2003)**

*ASTM International takes no position respecting the validity of any patent rights asserted in connection with any item mentioned in this standard. Users of this standard are expressly advised that determination of the validity of any such patent rights, and the risk of infringement of such rights, are entirely their own responsibility.*

*This standard is subject to revision at any time by the responsible technical committee and must be reviewed every five years and if not revised, either reapproved or withdrawn. Your comments are invited either for revision of this standard or for additional standards and should be addressed to ASTM International Headquarters. Your comments will receive careful consideration at a meeting of the responsible technical committee, which you may attend. If you feel that your comments have not received a fair hearing you should make your views known to the ASTM Committee on Standards, at the address shown below.*

*This standard is copyrighted by ASTM International, 100 Barr Harbor Drive, PO Box C700, West Conshohocken, PA 19428-2959, United States. Individual reprints (single or multiple copies) of this standard may be obtained by contacting ASTM at the above address or at 610-832-9585 (phone), 610-832-9555 (fax), or [service@astm.org](mailto:service@astm.org) (e-mail); or through the ASTM website ([www.astm.org](http://www.astm.org)).*