



Designation: F 451 – 99a<sup>ε1</sup>

## Standard Specification for Acrylic Bone Cement<sup>1</sup>

This standard is issued under the fixed designation F 451; the number immediately following the designation indicates the year of original adoption or, in the case of revision, the year of last revision. A number in parentheses indicates the year of last reapproval. A superscript epsilon ( $\epsilon$ ) indicates an editorial change since the last revision or reapproval.

---

---

<sup>ε1</sup> NOTE—Figure 1 was editorially corrected in June 2003.

---

---

### 1. Scope

1.1 This specification covers self-curing resins used primarily for the fixation of internal orthopedic prostheses. The mixture may be used in either the predough or dough stage in accordance with the manufacturer's recommendations.

1.2 Units of premeasured powder and liquid are supplied in a form suitable for mixing. The mixture then sets in place.

1.3 While a variety of copolymers and comonomers may be incorporated, the composition of the set cement shall contain poly(methacrylic acid esters) as its main ingredient.

1.4 This specification covers compositional, physical performance, and biocompatibility as well as packaging requirements. The

---

<sup>1</sup> This specification is under the jurisdiction of ASTM Committee F-4 F04 on Medical and Surgical Materials and Devices and is the direct responsibility of Subcommittee F04.11 on Polymeric Materials.

Current edition approved May 10, 1999. Published July 1999. Originally published as F 451 – 76. Last previous edition F 451 – 95.

biocompatibility of acrylic bone cement as it has been traditionally formulated and used has been reported in the literature (1, 2).<sup>2</sup>

1.5 This standard does not purport to address all of the safety concerns, if any, associated with its use. It is the responsibility of the user of this standard to establish appropriate safety and health practices and determine the applicability of regulatory limitations prior to use.

## 2. Referenced Documents

### 2.1 ASTM Standards:

D 695 Test Method for Compressive Properties of Rigid Plastics<sup>3</sup>

D 3835 Test Method for Determination of Properties of Polymeric Materials by Means of a Capillary Rheometer<sup>4</sup>

E 29 Practice for Using Significant Digits in Test Data to Determine Conformance With Specifications<sup>5</sup>

E 141 Practice for Acceptance of Evidence Based on the Results of Probability Sampling<sup>5</sup>

F 619 Practice for Extraction of Medical Plastics<sup>6</sup>

F 748 Practice for Selecting Generic Biological Test Methods for Materials and Devices<sup>6</sup>

F 749 Practice for Evaluating Material Extracts by Intracutaneous Injection in the Rabbit<sup>6</sup>

F 756 Practice for Assessment of Hemolytic Properties of Materials<sup>6</sup>

F 763 Practice for Short-Term Screening of Implant Materials<sup>6</sup>

F 813 Practice for Direct Contact Cell Culture Evaluation of Materials for Medical Devices<sup>6</sup>

F 895 Practice for Agar Diffusion Cell Culture Screening for Cytotoxicity<sup>6</sup>

F 981 Practice for Assessment of Compatibility of Biomaterials (Nonporous) for Surgical Implants with Respect to Effect of Materials on Muscle and Bone<sup>6</sup>

### 2.2 ANSI/ADA Standard:

No. 15 Specification for Acrylic Resin Teeth<sup>7</sup>

## 3. Terminology

### 3.1 Definitions of Terms Specific to This Standard:

3.1.1 *doughing time*—the time after commencement of mixing at which the mixture ceases to adhere to a standard probe (see 7.5).

3.1.2 *exothermic or maximum temperature*—the maximum temperature of the mixture due to self-curing in a standard mold (see 7.6).

3.1.3 *extrusion*—the rate of flow of the material through a standard orifice under load (see 7.8.1).

3.1.4 *intrusion*—the distance of flow of the mixture into a standard mold under load (see 7.8.2).

3.1.5 *setting time*—the time after commencement of mixing at which the temperature of the curing mass equals the average of the maximum and ambient temperatures (see 7.7).

3.1.6 *unit*—one package or vial of premeasured powder component and one package or vial of premeasured liquid component.

## 4. Physical Requirements

### 4.1 Liquid:

4.1.1 *Appearance*—The liquid shall be free of extraneous particulate matter or obvious visual contaminants in its container.

4.1.2 *Stability*—After being heated for 48 h at  $60 \pm 2^\circ\text{C}$ , the viscosity of the liquid shall not increase by more than 10 % of its original value (see 7.3).

4.1.3 *Sterility*—The liquid, as poured from its container, shall pass the tests described in “Sterility Tests—Liquid and Ointments” (7.4) (3).

### 4.2 Powder:

4.2.1 *Appearance*—The powder shall be pourable and free of extraneous materials, such as dirt or lint (7.2.2).

4.2.2 *Sterility*—The powder, as poured from its package, shall pass the tests described in “Sterility Tests—Solids” (7.4) (2).

### 4.3 Powder-Liquid Mixture:

4.3.1 If the mixture is to be used in its predough stage, the material shall conform to the properties given in Table 1.

4.3.2 If the mixture is to be used in its dough stage, the material shall conform to the properties given in Table 1.

4.3.3 If the mixture can be used in either its predough or dough stages, separate units must be tested for compliance with 4.3.1 and 4.3.2.

4.4 *Cured Polymer*—The material after setting shall conform to the properties given in Table 2.

## 5. Weights and Permissible Variations

5.1 Weight and volume measurements shall be made on the respective powder and liquid components of five units (see 3.1).

<sup>2</sup> The boldface numbers in parentheses refer to the list of references at the end of this standard.

<sup>3</sup> *Annual Book of ASTM Standards*, Vol 08.01.

<sup>4</sup> *Annual Book of ASTM Standards*, Vol 08.02.

<sup>5</sup> *Annual Book of ASTM Standards*, Vol 14.02.

<sup>6</sup> *Annual Book of ASTM Standards*, Vol 13.01.

<sup>7</sup> Available from American National Standards Institute (ANSI), 25 W. 42nd St., 43rd Floor, New York, NY 10036.

**TABLE 1 Requirements for Powder Liquid Mixture**

Property	Extrusion, Viscosity Tests	Dough Usage, Intrusion Tests
Max Dough Time, min.	5.0	5.0
Setting Time Range, min.	5 to 15	5 to 15
Temperature, max., °C	90	90
Intrusion, min., mm	...	2.0

**TABLE 2 Requirements for Cured Polymer After Setting**

Property	Requirement
Compressive Strength, min., MPa	70

These units may be subsequently utilized in any of the nonsterile tests of this specification.

5.2 The weights, or volume of the powder and liquid components, or both, shall not deviate by more than 5 % from those stated on the package (9.2.2), of each of five units.

5.3 Where a radiopaque material is supplied for addition to the powder at the discretion of the surgeon, the weight or volume percent of the radiopaque material shall not deviate by more than 15 % from the value stated on the package (9.2.3).

## 6. Sampling

6.1 Units of powder and liquid shall be procured to provide sufficient material for all the tests of this specification. The units shall be obtained from regular retail distribution channels. Provided no repeat tests are required, this will amount to between seven and ten units.

6.2 It will only be necessary to maintain sterility in tests described in 7.4. All other tests described in this specification need not be conducted under sterile conditions.

## 7. Test Methods and Sample Size

7.1 Maintain all equipment, mixing surfaces, and materials at  $23 \pm 2^\circ\text{C}$  at least 2 h prior to testing and conduct all tests at  $23 \pm 2^\circ\text{C}$  and  $50 \pm 10\%$  relative humidity unless otherwise specified.

7.2 *Inspection*—Use visual inspection in determining compliance to the requirements outlined in 4.1.1, 4.2.1, 8.1 and 8.2.

7.2.1 The liquid component of two separate units shall comply with the requirements of 4.1.1 and 8.1.

7.2.2 The powder component of two separate units shall comply with the requirements of 4.2.1 and 8.1.

7.3 *Liquid Component Viscosity*—Record the viscosity change of two separate units (4.1.2) before and after the heating exposure by timing the flow of the liquid level between the 0 and 5 mL marks of a 10 mL measuring pipet. Calculate the percent change as follows:

$$\% \text{ Change} = \frac{t_a - t_b}{t_b} \times 100 \quad (1)$$

where:

$t_b$  = flow time before heating, and

$t_a$  = flow time after heating exposure (4.1.2) of  $60 \pm 2^\circ\text{C}$  for 48 h in the dark in a closed container.

7.3.1 An alternative method for viscosity may be used if it can be demonstrated to yield similar results. Both shall comply to the less than 10 % change specified (4.1.2).

7.4 The components of the two units shall be tested for sterility in accordance with the test methods described in U.S. Pharmacopoeia, “Sterility Tests” (3).

7.5 *Doughing Time:*

7.5.1 *Environment*—All equipment, mixing surfaces, and material (unit size) shall be maintained at  $23 \pm 1^\circ\text{C}$  at least 2 h prior to testing and tests shall be conducted at  $23 \pm 1^\circ\text{C}$ . The relative humidity shall be  $50 \pm 10\%$ .

7.5.2 Mix all the powder and liquid of a single unit together as directed by the manufacturer’s instructions (see 8.2). Start a stop watch at the onset of combining the liquid to the powder and read all subsequent times from this stop watch. Approximately 1.5 min after the onset of mixing, gently probe the mixture with a non-powdered surgically gloved (latex) finger. Take visual notice as to the formation of fibers between the surface of the mix and the finger as it leaves the surface. Repeat this process from that time on at 15 s intervals with a clean portion of the glove until the gloved finger separates cleanly. Denote the time at which this is first observed as the doughing time. Mix the mixture between determinations to expose fresh material for each probing.

7.5.3 Determine the average doughing time from two separate units.

7.5.4 The two values found shall agree within 30 s of each other, otherwise repeat the test on two additional units. Report the average of all four tests and the range of values.

7.5.5 Report the doughing time to the nearest 15 s as the average of all determinations. Maximum and minimum values of doughing times measured shall not differ by more than  $\pm 1\frac{1}{2}$  min from the average.

7.6 *Exothermic Temperature*—Within 1 min after doughing time, gently pack approximately 25 g of the dough described in 7.5 into the mold described in Fig. 1. This mold shall be made of polytetrafluoroethylene (PTFE), poly(ethyleneterephthalate), polyoxymethylene, high density polyethylene, or ultra-high molecular weight polyethylene (UHMWPE) and be equipped with a No. 24 gage wire thermocouple, or similar device, positioned with its junction in the center of the mold at a height of 3.0 mm in the internal cavity. Immediately seat the plunger with a C-clamp or suitable press to produce the 6.0 mm specimen height. Upon producing plunger seating, remove the excess material and the C-clamp or press for the remainder of the procedure. Continuously record the temperature with respect to time from the onset of mixing the liquid and the powder until cooling is observed, Fig. 2. Report the maximum temperature recorded to the nearest 1°C. This should not exceed the value given in Table 1.

7.6.1 The maximum temperature shall be the average of two separate determinations reported to the nearest 1°C.

7.6.2 If the difference between the maximum temperature for the two determinations is greater than 5.0°C, repeat the test on two additional units and report the average of all four runs to the nearest 1°C. Individual maximum and minimum values for maximum temperature shall not differ by more than ±4°C of the average value of all determinations.

7.7 *Setting Time*— From the continuous time versus temperature recording of 7.6, the setting time ( $T_{set}$ ) is the time when the temperature of the polymerizing mass is as follows:

$$(T_{max} + T_{amb})/2 \tag{2}$$

where:

$T_{max}$  = maximum temperature, °C, and

$T_{amb}$  = ambient temperature of 23 ± 1°C.

7.7.1 Report the setting time to the nearest 5 s.

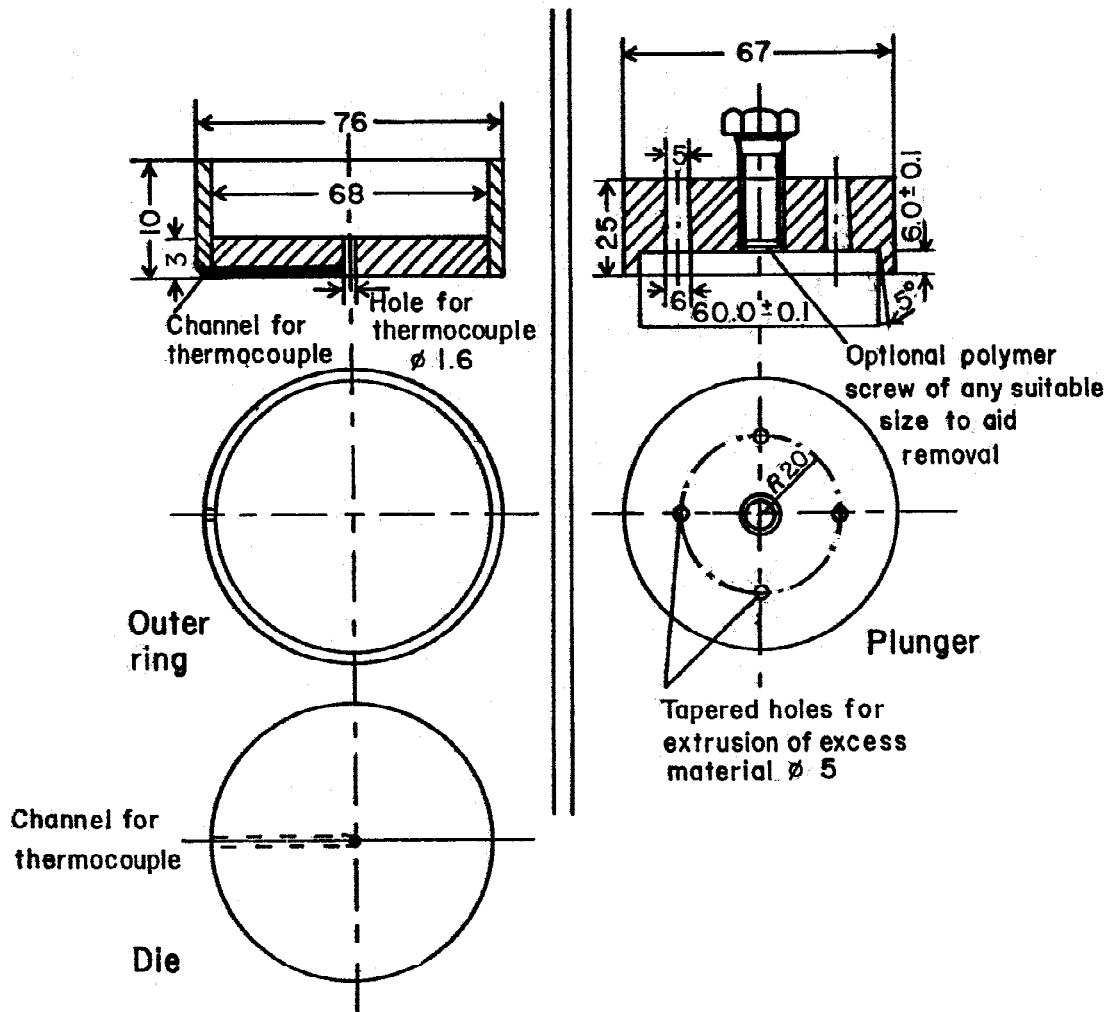

NOTE 1—Dimensions in millimetres and ±0.2 unless otherwise specified. Material for all components: Polytetrafluoroethylene, poly(ethyleneterephthalate), polyoxymethylene, high density polyethylene, or ultra-high molecular weight polyethylene (UHMWPE).

FIG. 1 Exothermic Heat Mold

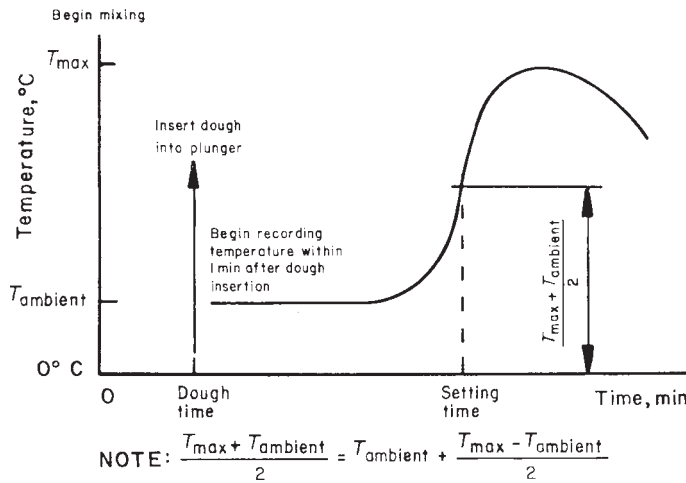

FIG. 2 Continuous Temperature Record

7.7.2 Make two separate determinations of the setting time.

7.7.3 The two values should agree within 1 min of each other, otherwise repeat the test on two additional units and report the average of all runs.

7.7.4 Report the setting time to the nearest 15 s as the average of all determinations.

7.8 *Flow Properties and Viscosity Determination*—The manufacturer must specify whether the cement may be used in its pre-dough or dough state, or both. The determination of its usage dictates which of the following tests the cement should comply with. If the mixture is to be utilized in the pre-dough stage, use the extrusion, viscosity test (7.8.1) and Table 1. If the mixture is to be utilized in the dough stage, use the intrusion test (7.8.2) and Table 1. If the mixture is to be used as a dual usage cement, then both the extrusion (7.8.1) and intrusion (7.8.2) tests must be performed.

7.8.1 *Extrusion, Viscosity:*

7.8.1.1 *Apparatus:*

7.8.1.1.1 *Rheometer*—Any capillary rheometer is satisfactory in which acrylic bone cement can be forced from a reservoir through a capillary die and in which temperature, applied force, output rate, and barrel and die dimensions can be controlled and measured accurately. Equipment that provides a constant shear rate has been shown to be equally useful. The capillary die of the rheometer shall have a smooth straight bore that is held within  $\pm 0.0076$  mm ( $\pm 0.0003$  in.) in diameter and shall be held to within  $\pm 0.025$  mm ( $\pm 0.001$  in.) in length. The bore and its finish are critical. It shall have no visible drill or other tool marks and no detectable eccentricity.

7.8.1.1.2 Due to the extreme sensitivity of flow data to the capillary dimensions, it is important that the capillary dimensions are measured with precision and reported. The length to diameter ratio shall normally be between 20 and 40. Larger ratios and ratios less than that suggested require applying large corrections to the data (4, 5). In addition, the ratio of the reservoir diameter to capillary diameter should be between 3 and 15. See Test Method D 3835 for further details of capillary rheometers.

7.8.1.2 *Calibration*—Perform the test with a certified standard viscosity fluid approximating that expected for bone cement (50 N·s/m<sup>2</sup> to 500 N·s/m<sup>2</sup>). Determine the viscosity of the standard fluid and the percent error from its specified value. Report this error along with the viscosity of the tested cements.

7.8.1.3 *Corrections*—Since bone cement is a non-Newtonian fluid, the data may be reported as corrected data. For example, true shear rates, corrected for non-Newtonian flow behavior and true shear stress corrected for end effects or kinetic energy losses, may be calculated. In such cases, the exact details of the mode of correction must be reported. Some correction factors which may apply are:

- ((a) (a) Piston friction,
- ((b) (b) Plunger back flow,
- ((c) (c) Cement compressibility,
- ((d) (d) Barrel back pressure,
- ((e) (e) Capillary entrance effects (Bagley correction) (6),
- ((f) (f) Rabinowitsch shear rate correction (7).

7.8.2 *Procedure:*

7.8.2.1 Select conditions of temperature and shear stress or shear rate in accordance with expected usage so that the flow rate will fall within desired limits.

7.8.2.2 Inspect the rheometer and clean it if necessary. Ensure that previous cleaning procedures and usage have not changed the dimensions or caused scratches or defects in the capillary or apparatus. Make the necessary measurements on the apparatus for future calculations. Prepare the apparatus for running the test.

7.8.2.3 Mix one or more complete unit(s) of powder and liquid in the recommended manner. Start a stop watch at the onset of

mixing and read all subsequent times from this watch. After complete mixing, transfer the cement to the thermally equilibrated reservoir, and eject any entrapped air or excess bone cement.

7.8.2.4 Start the apparatus at a time not greater than 2½ min from the start of mixing and continue operating until the estimated dough time or the viscosity exceeds 500 N·s/m<sup>2</sup>.

7.8.2.5 Disassemble the apparatus quickly before the cement sets and clean the apparatus of all remaining cement.

7.8.3 *Calculations*— Perform the calculation for viscosity of the cement at time intervals of 15 s from the start to finish of test run. Use the following equations:

$$\text{Shear Stress, Pa} = \frac{Pr}{2L} = \frac{Fr}{2\pi R^2 L} \quad (3)$$

$$\text{Shear Rate, s}^{-1} = \frac{4Q}{\pi r^3} = \frac{4V}{\pi r^3 t} \quad (4)$$

$$\text{Viscosity, Pa} \cdot \text{s} = \frac{P\pi r^4}{8LQ} = \frac{Fr^4 t}{8R^2 LV} \quad (5)$$

where:

- $P$  = pressure by ram, Pa,
- $F$  = force on ram,  $N$ ,
- $r$  = radius of capillary, m,
- $R$  = radius of barrel, m,
- $L$  = length of capillary, m,
- $Q$  = flow rate, m<sup>3</sup>/s,
- $V$  = volume extruded, m<sup>3</sup>, and
- $t$  = extrusion time, s.

7.8.3.1 These equations yield true shear rate and true viscosity for Newtonian fluids only; for non-Newtonian fluids, such as bone cement, the apparent shear rate and viscosity are obtained.

7.8.4 *Report*—The report of the flow properties of the cement shall include:

- 7.8.4.1 Description of the rheometer used.
- 7.8.4.2 Temperature at which the data were obtained.
- 7.8.4.3 The capillary diameter and length to diameter ratio of the capillary.
- 7.8.4.4 The shear rate at which the test was performed.
- 7.8.4.5 Viscosity versus observation time for three runs.
- 7.8.4.6 Statement as to whether any correction factors (7.8.1.3) were applied.

7.8.5 *Intrusion*:

7.8.5.1 The mold necessary for this test shall be made of polytetrafluoroethylene (PTFE), poly(ethyleneterephthalate), polyoxymethylene, high density polyethylene, or ultra-high molecular weight polyethylene (UHMWPE) and is shown in Fig. 3.

7.8.5.2 Following the set, remove the specimen and measure the average height of the intrusion into all four of the 1.0-mm diameter holes of the die to the nearest 0.5 mm.

7.8.5.3 Run this test once. If the requirement is not met, it must be met so in a repeat test.

7.9 *Compressive Strength*—The test specimens shall be cylinders 12 mm high and 6 mm in diameter. The ends of the specimens shall be flat and smooth and shall be parallel to each other and at right angles to the long axis of the cylinder. An apparatus found convenient for forming these test cylinders is shown in Fig. 4. An apparatus containing more or less holes may be used as long as adequate spacing between holes is maintained. A mold release agent or silicone spray may be sparingly applied to facilitate specimen removal.

7.9.1 Place the specimen mold on a flat glass or smooth metal plate and slightly overfill using one unit of mixed cement of standard proportions at the commencement of dough time. Press a second flat glass or smooth metal plate on top of the mold. Hold the mold and plates firmly together with a small C-clamp. Then, 1 h later, surface the ends of the cylinder plane at right angles to the axis. The ends of the specimens may be ground flat to the axis by use of a small amount of 240-mesh silicon carbide powder and water. Draw the molds containing the specimens back and forth across the plate coated with the abrasive and water. After surfacing, remove the specimens from the mold. The specimens should be visually examined for surface defects. A surface defect is defined as a surface discontinuity greater than 500 microns in major diameter. Acceptable specimens for testing shall appear to be uniform and meet the dimensional requirements of 7.9. A minimum of five specimens shall be selected from the remaining acceptable specimens and tested. Report the results of all specimens tested.

7.9.2 The time lapse between the start of mixing and the measurement of the compressive strength testing shall be 24 ± 2 h. Storage of the specimens before testing shall be at 23 ± 2 °C and 50 ± 10 % relative humidity. Run specimens on any universal testing machine equipped to record load versus deformation. Employ a deformation cross head speed of 20 to 25.4 mm/min. Test the specimens without use of any type of pad between the specimen and the platens of the machine. The failure load shall be the

**ASTM F 451 – 99a<sup>ε1</sup>**

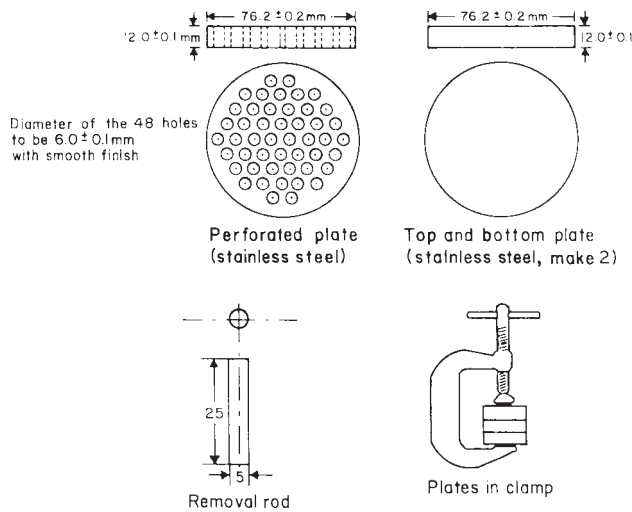

**FIG. 4 Compression Specimens Mold**

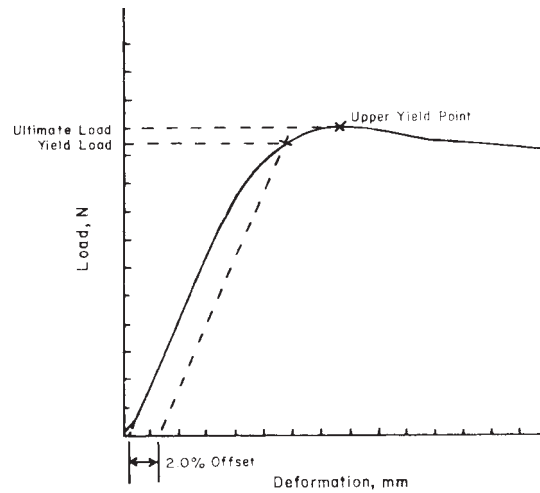

**FIG. 5 Failure Load Criteria**

load at the 2.0 % offset (2.0% proof stress), upper yield point, or at fracture, whichever occurs first (Fig. 5).

7.9.2.1 The load at 2.0 % offset is the load at the intersection of the S/N curve and a straight line parallel to the Hookean portion of the S/N curve (See Fig. X1.1 in Test Method D 695) but offset along the strain axis by 2.0 % of the test's gauge length (specimen's height).

7.9.2.2 Calculate the compressive strength as the failure load divided by the calculated cross-sectional area.

7.9.2.3 Report the compressive strength of the material as the average of the compression strengths of the specimens tested in 7.9.2 to the nearest 1 MPa (145 psi). A minimum of five specimens is required.

7.10 *Precision and Bias*—Since 1976, the original Specification F 451 methodologies have reportedly been routinely utilized by the various manufacturers. With the exception of the viscosity method of 7.8.1, which is based on another accepted ASTM document (Test Method D 3835), each test methodology in Section 7 contains its own statement of reporting acceptable levels of performance, reproducibility, and precision. Therefore, no interlaboratory studies have been performed by the Committee F-4.

## 8. Packaging

8.1 Materials shall be supplied in properly sealed containers made of materials that shall not contaminate or permit contamination of the contents. The containers shall be packaged so as to prevent damage or leakage during shipping and storage. Materials must be packaged to permit sterile transfer of contents to the sterile field.

8.2 The contents shall be easily accessible, easy to open, and convenient to mix in the operating room. Entire package contents (both powder and liquid) must be mixed to achieve recommended proportions.

## 9. Labeling

9.1 Labeling on these cements must be in conformance with the Federal Food, Drug, and Cosmetic Act, Code of Federal Regulations, and other pertinent laws and regulations.

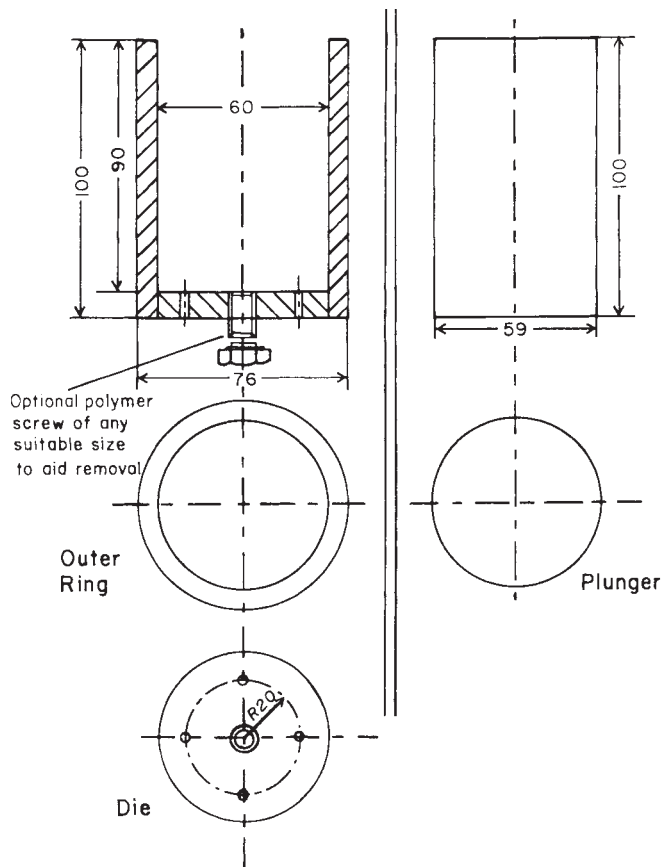

NOTE 1—Dimensions in millimetres; 4 holes in bottom to be  $1.00 \pm 0.05$ . Tolerance on all other dimensions  $\pm 0.2$ . Material for all components: Polytetrafluoroethylene, poly(ethyleneterephthalate), polyoxymethylene, high density polyethylene, or ultra-high molecular weight polyethylene (UHMWPE).

FIG. 3 Intrusion Mold

9.2 The following minimal information must appear on the container label.

9.2.1 It shall be clearly stated or color coded, or both, if the mixture is intended for usage in the pre-dough, dough, or dual usage state.

9.2.2 The weight or volume, or both, of the liquid and powder components must be stated.

9.2.3 Constituents of the powder and liquid shall be clearly stated in terms of weight or volume percent. This shall include the generic names of polymers, copolymers, chemical initiators, stabilizers, cross-linking agents, and any other ingredients, such as radiopacify agents, gels, fillers, or antibiotics.

9.2.4 A statement that the contents are sterile and that the sterility shall be guaranteed only if the containers are undamaged.

9.2.5 The following warning shall appear on the label: (a) Flammable liquid; (b) Store below 25°C, and (c) Protect from light.

9.2.6 A statement to the effect that federal law restricts this device for sale by or on the order of a physician should be displayed.

9.2.7 The manufacturer and distributor shall be identified.

9.2.8 Each individual component of the package unit must be clearly identified as to batch or lot number.

9.3 The following information shall appear on the product insert labeling accompanying each package.

9.3.1 Adequate and accurate instruction shall be given for handling the components and preparing the cement. Instructions shall include a directive to mix all of the powder with all the liquid of a single unit. Procedures required to mix the materials, along with recommended mixing utensils, shall be given.

9.3.2 Proper technique for administration and recommended procedures for using the cement, including any special precautions, shall be indicated.

9.3.3 Toxic, hazardous, or irritating characteristics associated with the handling and use of the components and cement shall be indicated.

9.3.4 A statement shall be included that states that high temperatures of either the ambient surroundings or material will cause shorter doughing, working, and setting times, while low temperatures of either the ambient surroundings or material will increase doughing, working, and setting times.



9.3.5 The ranges of doughing and setting times as measured at  $23 \pm 1^\circ\text{C}$  (7.5 and 7.7) shall be clearly stated.

## 10. Biocompatibility

10.1 The biocompatibility of acrylic bone cement has been reported in the literature (1, 2). The material has been shown to produce a well characterized level of biological response following long-term clinical use and laboratory studies. The results of these studies and the clinical history indicate an acceptable level of biological response in applications in which the material has been utilized. When new applications of the material, or significant modification to the material, or its physical forms are being contemplated, the recommendations of Practice F 748 and testing as described in Practices F 619, F 749, F 756, F 763, F 813, F 895, and F 981 should be considered.

## 11. Keywords

11.1 acrylic bone cement; compression strength; doughing time; exothermic temperature; extrusion; intrusion; poly(methacrylic acid esters); setting time

## APPENDIX

### (Nonmandatory Information)

#### X1. RATIONALE

X1.1 Acrylic bone cement is a powder-liquid system that is currently sold in the United States for the fixation of internal orthopedic appliances. Because it plays a key role in highly synchronized surgical procedures, such as total joint replacement, its setting characteristics must be known and consistent each time. The material must also have adequate physical properties for placement and function. To these ends, the standard is addressed.

X1.2 While many of the tests are obvious forms of good manufacturing practice, others may be slightly more subtle and require some elaboration.

X1.2.1 The stability test measures the viscosity after storing the liquid at  $60^\circ\text{C}$ . This is an accelerated aging test to ensure that the monomeric component of the bone cement does not readily polymerize prematurely while stored before use.

X1.2.2 The dough and set times check that the material will be ready for placement at the proper time in the surgical procedure *and that it will set* neither prematurely nor in a delayed fashion.

X1.2.3 The maximum temperature test makes sure that the mass will *not release excessive heat* during setting. This could be damaging to the patient's tissue if not properly controlled.

X1.2.4 The dough and setting times and maximum temperature test also evaluate other important parameters. These tests will only respond consistently in the required time and temperature ranges if the powder particle size distribution, the liquid to powder ratio, the complex chemical compositions of both the powder and liquid, and the catalyst amount and distribution have been properly formulated and meted out and strict quality control during all stages of manufacturing is carefully monitored.

X1.2.5 The viscosity tests of the predough material and intrusion evaluations demonstrate that the material will flow into the bony interstices and around prostheses to produce adequate mechanical interlocking upon setting of the material.

X1.2.6 The compressive strength test measures if the set material will be strong enough for clinical applications.

X1.3 Further topics presently under consideration for eventual addition to the specification are as follows:

X1.3.1 Other mechanical tests, such as tension, flexion, and fracture toughness, which may be more sensitive to internal porosity and surface defects than the current compression test.

X1.3.2 Statement of biocompatibility of the cement.

X1.3.3 Shortening the time spans of the indentation tests.

X1.3.4 Requiring doughing and setting time data to be furnished with product information.

X1.3.5 Investigating changes in physical properties when leachable additives, such as antibiotics, are purposefully added.

X1.3.6 To define the optimum conditions of the viscosity test methodology so that the performance standards can be established.

X1.4 It should be noted that this document contains both test methodology and performance standards. Currently, in the case of viscosity measurement, only the test methodology has been described. This methodology will serve as a basis for future performance standards.

**REFERENCES**

- (1) Williams, D. F., and Roaf, R., *Implants in Surgery*, W. B. Saunders Co., Ltd., London, 1973, pp 216–218.
- (2) Linder, L., *Biocompatibility of Orthopedic Implants*, Vol II, Boca Raton: CRC Series in Biocompatibility, Williams, D. F. (ed.), CRC Press, 1982, pp. 1 to 23.
- (3) *U.S. Pharmacopoeia*, Revision 20, Mack Publishing Co., Easton, PA, 1980, p 880.
- (4) Tordella, J. P., ed., *Transactions of the Society of Rheology*, Vol 1, 1957, p 203.
- (5) Philippoff, W., and Gaskins, F. H., eds., *Transactions of the Society of Rheology*, Vol 2, 1958, p 263.
- (6) Bagley, E. B., and Birk, A. M., eds., *Journal of Applied Physics*, Vol 31, 1960, p 556.
- (7) Rabinowitsch, R., *Zeitschrift Fuer Physikalische Chemie*, Vol A145, 1929, p 1.

*ASTM International takes no position respecting the validity of any patent rights asserted in connection with any item mentioned in this standard. Users of this standard are expressly advised that determination of the validity of any such patent rights, and the risk of infringement of such rights, are entirely their own responsibility.*

*This standard is subject to revision at any time by the responsible technical committee and must be reviewed every five years and if not revised, either reapproved or withdrawn. Your comments are invited either for revision of this standard or for additional standards and should be addressed to ASTM International Headquarters. Your comments will receive careful consideration at a meeting of the responsible technical committee, which you may attend. If you feel that your comments have not received a fair hearing you should make your views known to the ASTM Committee on Standards, at the address shown below.*

*This standard is copyrighted by ASTM International, 100 Barr Harbor Drive, PO Box C700, West Conshohocken, PA 19428-2959, United States. Individual reprints (single or multiple copies) of this standard may be obtained by contacting ASTM at the above address or at 610-832-9585 (phone), 610-832-9555 (fax), or [service@astm.org](mailto:service@astm.org) (e-mail); or through the ASTM website ([www.astm.org](http://www.astm.org)).*