



Designation: **F 564 – 002**

## Standard Specification and Test Methods for Metallic Bone Staples<sup>1</sup>

This standard is issued under the fixed designation F 564; the number immediately following the designation indicates the year of original adoption or, in the case of revision, the year of last revision. A number in parentheses indicates the year of last reapproval. A superscript epsilon ( $\epsilon$ ) indicates an editorial change since the last revision or reapproval.

### 1. Scope

1.1 This specification covers characterization of the design and mechanical function of metallic staples used in the internal fixation of the muscular skeletal system. It is not the intention of this specification to describe or specify specific designs for metallic bone staples.

1.2 This specification includes the following four test methods for measuring mechanical properties of metallic bone staples:

1.2.1 Test Method for Constant Amplitude Bending Fatigue Tests of Metallic Bone Staples—Annex A1.

1.2.2 Test Method for Pull-Out Fixation Strength of Metallic Bone Staples—Annex A2.

1.2.3 Test Method for Soft Tissue Fixation Strength of Metallic Bone Staples—Annex A3.

1.2.4 Test Method for Elastic Static Bending of Metallic Bone Staples—Annex A4.

1.3 Unless otherwise indicated, the values stated in SI units are to be regarded as standard. The values given in parentheses are given for information only.

1.4 *This standard does not purport to address all of the safety concerns, if any, associated with its use. It is the responsibility of the user of this standard to establish appropriate safety and health practices and determine the applicability of regulatory limitations prior to use.*

### 2. Referenced Documents

2.1 *ASTM Standards:*

<sup>1</sup> This specification is under the jurisdiction of ASTM Committee F04 on Medical and Surgical Materials and Devices and is the direct responsibility of Subcommittee F04.21 on Osteosynthesis.

Current edition approved ~~May~~ Apr. 10, 2000<sup>2</sup>. Published ~~August 2000~~. June 2002. Originally published as F 564 – 85. Last previous edition ~~F 564 – 85 (1997)<sup>1</sup>~~. F 564 – 00.

E 4 Practices for Force Verification of Testing Machines<sup>2</sup>

E 122 Practice for ~~Choice of~~ Calculating Sample Size to Estimate, ~~With a Measure of Quality Specified Tolerable Error, the~~ Average for a Characteristic of a Lot or Process<sup>3</sup>

E 467 Practice for Verification of Constant Amplitude Dynamic ~~Loads Forces~~ in an Axial Load Fatigue Testing Machine<sup>2</sup>

F 75 Specification for Cast Cobalt-28Chromium-6Molybdenum Alloy for Surgical ~~Implant Applications~~ Implants (UNS R30075)<sup>4</sup>

F 86 Practice for Surface Preparation and Marking of Metallic Surgical Implants<sup>4</sup>

F 382 Test Method for Static Bending Properties of Metallic Bone Plates<sup>4</sup>

~~F 565 Standard Practice~~ 565 Practice for Care and Handling of Orthopedic Implants and Instruments<sup>4</sup>

F 601 Practice for Fluorescent Penetrant Inspection of Metallic Surgical Implants<sup>4</sup>

F 629 Practice for Radiography of Cast Metallic Surgical Implants<sup>4</sup>

### 3. Finish

3.1 Staples conforming to this specification shall be finished and identified in accordance with Practice F 86, as appropriate.

### 4. Inspection Practices

4.1 Staples made in accordance with Specification F 75 should be inspected in accordance with Practice F 601 or X-rayed in accordance with Practice F 629.

### 5. Care and Handling

5.1 Staples should be cared for and handled in accordance with Practice F 565, as appropriate.

### 6. Keywords

6.1 bending test; bone fixation; fatigue test; fixation devices; metallic bone staples; orthopaedic medical devices; pullout test; soft tissue fixation; surgical implants

---

<sup>2</sup> Annual Book of ASTM Standards, Vol 03.01.

<sup>3</sup> Annual Book of ASTM Standards, Vol 14.02.

<sup>4</sup> Annual Book of ASTM Standards, Vol 13.01.

## ANNEXES

### (Mandatory Information)

#### A1. TEST METHOD FOR CONSTANT AMPLITUDE BENDING FATIGUE TESTS OF METALLIC BONE STAPLES

##### A1.1 Scope

A1.1.1 This test method covers procedures for the performance of constant amplitude fatigue testing of metallic staples used in internal fixation of the musculoskeletal system. This test method may be used when testing in air at ambient temperature or in an aqueous or physiological solution.

A1.1.2 The values stated in SI units are to be regarded as the standard.

A1.1.3 *This standard does not purport to address all of the safety concerns, if any, associated with its use. It is the responsibility of the user of this standard to establish appropriate safety and health practices and determine the applicability of regulatory limitations prior to use.*

##### A1.2 Summary of Test Method

A1.2.1 Metallic bone staples are tested under bending loads until the specimen fails or a predetermined number of cycles has been applied to it. Bending tests may be performed in one of two modes: either pure, in-plane bending; or tension (or compression) combined with in-plane bending. Tests using either of these methods may be conducted at ambient conditions or in aqueous or physiological solutions (at either room temperature or 37°C).

##### A1.3 Significance and Use

A1.3.1 This test method is used to determine the fatigue resistance of metallic bone staples when subjected to repetitive loading for large numbers of cycles. This information may also be useful for comparing the effect of variations in staple material, geometry, surface condition, or placement under certain circumstances.

A1.3.2 It is essential that uniform fatigue practices be established in order that such basic fatigue data be comparable and reproducible and can be correlated among laboratories.

A1.3.3 The results of fatigue tests are suitable for direct application to design only when the service conditions parallel the test conditions exactly. This test method may not be appropriate for all types of bone staple applications. The user is cautioned to consider the appropriateness of the test method in view of the materials being tested and their potential application.

**A1.4 Apparatus**

A1.4.1 *Testing Machines*, conforming to the requirements of Practices E 4 and E 467. The loads used for determining strengths shall be within the loading range of the testing machine as defined in Practices E 4 and E 467.

A1.4.2 *Gripping Devices:*

A1.4.2.1 *Staple Extensions*—Pairs of specially designed metal blocks that permit the holding of individual staples for the application of bending fatigue loads. The legs of each staple are fitted into fixation holes in each block with minimal clearance to restrict bending of the staple within the hole. The staple is fixed securely in the block using a moldable filling or grouting agent. The extension design should minimize the weight to reduce the influence on the staple while maintaining sufficient stiffness to transfer the load to the staple without undesirable deflection. Holes for pin and clevis fixation are optional (see Figs. A1.1-A1.3).

NOTE A1.1—Variations in fixation hole configuration may be required for staple legs with noncircular cross sections. Also, it is necessary to provide a gap between the underside of the staple bridge and edge of the staple extender in most cases. This is necessary to eliminate contact between the staple bridge (or other bridge features such as tissue spikes) and the staple extender. However, this gap should be standardized within any test group as required.

A1.4.2.2 *4-Point Bend Fixture*—A standard or modified bending fixture that produces pure bending in the staple without appreciable shear or torsion when used to apply load to the staple through the staple extensions.

A1.4.2.3 *Pin and Clevis Fixture*—A standard or modified fixture used to apply a distractive or compressive load to the staple through the staple extensions to produce bending in the staple similar to that seen in vivo.

A1.4.3 *Filling or Grouting Agent*—A stiff, moldable filler, such as epoxy, acrylic cement, or a low-melting point alloy (for example, Wood’s metal) used to secure the staple leg within the staple extension.

A1.4.4 *Aqueous Solution*—Tap water, distilled water, physiological saline, or similar aqueous solutions, used to immerse the test specimens fully during the test.

A1.4.5 *Constant Temperature Bath*—An aqueous bath capable of maintaining the samples and containers at physiologic temperatures,  $37 \pm 2^\circ\text{C}$ , for the specified testing periods.

**A1.5 Test Specimen**

A1.5.1 *Staple*—A generally U-shaped metal loop, with at least two legs, that is driven into the surface of bone to either fix or immobilize adjacent pieces of bone or to fasten soft tissue or other material to bone. All test samples shall be representative of the material under evaluation. Samples for comparative tests shall be produced from the same material lot or batch and under the same fabricating conditions, unless noted specifically.

A1.5.2 *Staple Leg*—The parallel or nearly parallel extensions that are intended to penetrate the bone tissue; these may be round, square, or polygonal in cross section, and they may possess serrations or barbs to increase the fixation or purchase strength in the bone.

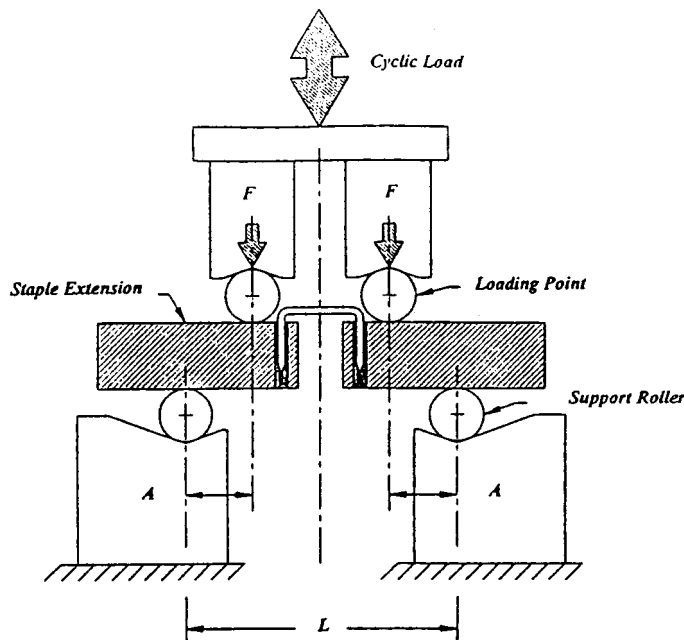

FIG. A1.1 4-Point Bending of Staples in Extension

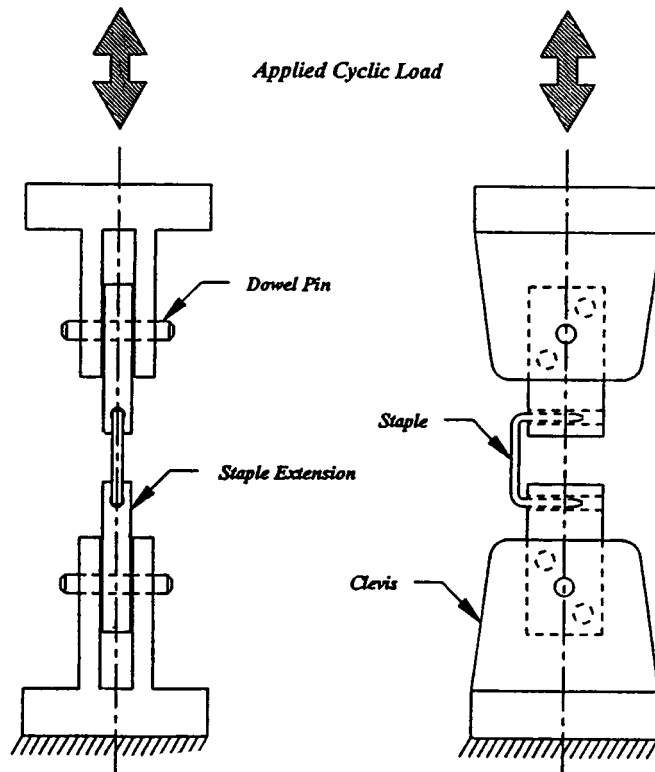

FIG. A1.2 Combined Tension (or Compression) and Bending of Staples

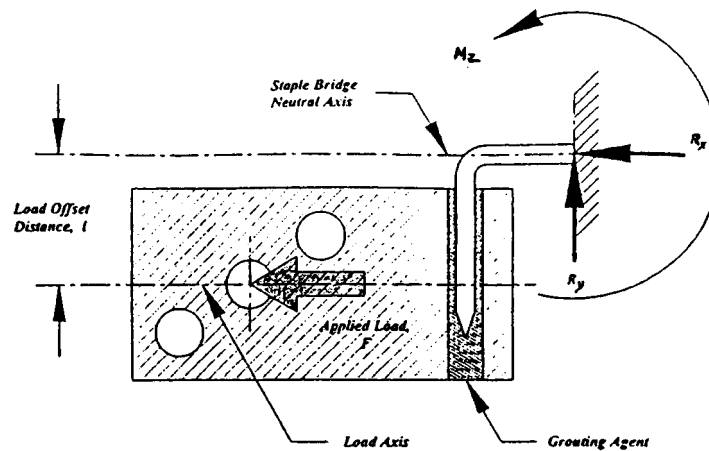

FIG. A1.3 Diagram of Extender-Staple Forces Under Combined Bending and Tension

A1.5.3 *Staple Bridge*—The cross member of the staple connecting the legs; the bridge may be smooth or possess spikes or projections on the underside for the retention of soft tissue or other material.

**A1.6 Procedure**

A1.6.1 *Mounting the Specimen*—Fix the staple leg in an extension block using the filling agent. A fixture should be used to ensure proper in-plane alignment of the two extensions and the staple during this process. Also, each staple should be fixed such that the bridge is the same distance from the top of each extension.

NOTE A1.2—This distance is at the discretion of the operator, but it determines the portion of the staple subjected to the bending loads.

A1.6.2 *4-Point Bend Testing:*

A1.6.2.1 Place the staple and attached staple extensions in the 4-point bending fixture such that the loading point and support rollers contact the staple extensions on either side of the staple; direct contact of the rollers with the staple shall not be permitted during the test. Alignment of the loading point rollers shall be symmetric on the centerline between the support rollers (see Fig. A1.1).

A1.6.2.2 Apply cyclic loads (sinusoidal, sawtooth, ~~etc.~~, and so forth), generating bending moments in the staple without permanent deformation. Appropriate starting loads should be 50 to 75 % of the static bending strength, unless indicated otherwise.

NOTE A1.3—It may be necessary to provide a low-friction means of maintaining the position of the staple and attached extensions. Also, the fixtures should be designed so that loads are applied equally at the loading points during each deflection throughout the test.

A1.6.2.3 Compute the bending moment,  $M$ , by the following formula, where  $F$  = force applied at each loading point and  $A$  = distance between the loading point and support roller,  $M_{\text{bending}} = FA$ .

A1.6.2.4 Continue the test until failure of the staple or the fixation or a predetermined number of load cycles has been applied.

A1.6.3 *Combined Tension or (Compression) and Bending:*

A1.6.3.1 Place the staple and attached staple extensions in the axial bending fixture. The pins and clevises should permit free rotation of the staple extensions, with minimal friction, while maintaining alignment of the staple legs (and extensions) in the same plane (see Fig. A1.2).

A1.6.3.2 Apply cyclic loads (sinusoidal, sawtooth, ~~etc.~~, and so forth), generating bending moments in the staple without permanent deformation. Appropriate starting loads should be 50 to 75 % of the static yield strength, unless indicated otherwise.

NOTE A1.4—It may be necessary to maintain a minimum tensile or compressive load on the specimen throughout the test, since operating at or near zero load may result in either loss of machine control due to discontinuity in the load feedback loop or undesirable transient loading of the staple.

A1.6.3.3 Compute the bending moment in the staple bridge,  $M$ , by the following formula, where  $F$  = force applied at each center of each pin and  $L$  = distance between the load application axis, that is, the pin center, and the neutral axis of the staple bridge,  $M_{\text{bending}} = FL$  (see Fig. A1.3).

NOTE A1.5—The application of this test method produces bending, tensile (or compressive), and shear stresses in the staple. The direction and magnitudes of these stresses should be analyzed using superposition theory or other suitable methods.

A1.6.3.4 Continue the test until failure of the staple or the fixation or a predetermined number of load cycles has been applied.

A1.6.4 *Stress Verification*—It is recommended that strain gages (or extensometry) be used to measure the bending strains induced in the specimen. This is accomplished most easily on the staple bridge, but it may be possible to perform on a portion of the staple leg or at the leg-bridge junction under certain circumstances and with certain staple designs. The recommended technique is to strain gage the actual fatigue test specimens, if possible, provided that the installation of strain gage will not influence the test results.

## A1.7 Test Termination

A1.7.1 Continue the tests until the specimen fails or a predetermined number of cycles has been applied to the specimen. Failure should be defined as complete separation, a crack visible at a specified magnification, a crack of certain dimensions, or by some other criterion. State the criterion selected for defining failure when reporting the results.

A1.7.2 A test shall be considered invalid if a loosening of the staple occurs in the embedding medium or if noticeable yielding or permanent deformation occurs in the specimen.

## A1.8 Report

A1.8.1 Report the following information:

A1.8.1.1 *Staple Description*—Type, size, special features (barbs, spikes, and so forth), manufacturer, material, batch or lot number, and dimensions (including leg length, bridge width, and length), as appropriate.

A1.8.1.2 *Test Type*—4-point or combined tension (or compression) and bending.

A1.8.1.3 *Fixation Geometry*—Load point separation distances (4-point bending), load offset distance (combined tension and bending), staple bridge-extension distance, and so forth.

A1.8.1.4 Minimum and maximum cycle loads, test frequency (for example, cycles/s), and forcing function type (sine, ramp, saw tooth, and so forth).

A1.8.1.5 Bending moment,  $M$  (N-m).

A1.8.1.6 Load ratio,  $R$ , where  $R$  = minimum load/maximum load.

A1.8.1.7 *Test Environment*—Ambient air or physiological solution.

A1.8.1.8 Number of cycles at failure or test termination (runout).

A1.8.1.9 Location of fatigue fracture (if applicable).

A1.8.1.10 Reason for test termination, that is, staple failure, fixation failure, runout to specified cycle limit, ~~etc.~~ and so forth.

## A1.9 Precision

A1.9.1 Intralaboratory and interlaboratory reproducibility have not been determined systematically.

## A1.10 Rationale (Nonmandatory Information)

A1.10.1 This test method is intended to aid in characterizing the fatigue behavior of metallic bone staples used for the fixation of bone to bone or soft tissue to bone. The data obtained using this test method may be used to compare staple materials, designs, or placements under certain circumstances.

A1.10.2 This test method is intended to simulate potential in vivo staple loading conditions. However, in vitro testing of these devices may not duplicate their in vivo behavior adequately.

## **A2. TEST METHOD FOR PULL-OUT FIXATION STRENGTH OF METALLIC BONE STAPLES**

### **A2.1 Scope**

A2.1.1 This test method covers testing of the hard tissue pull-out fixation strength of metallic staples used in the internal fixation of the musculoskeletal system. This test method may be used with physiologic bone or a synthetic substitute. It may also be used when testing in an aqueous or physiological solution.

A2.1.2 The values stated in SI units are to be regarded as the standard.

A2.1.3 *This standard does not purport to address all of the safety concerns, if any, associated with its use. It is the responsibility of the user of this standard to establish appropriate safety and health practices and determine the applicability of regulatory limitations prior to use.*

### **A2.2 Summary of Test Method**

A2.2.1 A thin, flat, flexible metal or fabric strap is fixed to bone (or a substitute) using a single staple. Tension is applied equally to both ends of the strap in a direction parallel to the staple legs until loss of staple fixation occurs. Tests using this test method may be conducted at ambient conditions or in aqueous or physiological solutions at either room temperature or 37°C.

### **A2.3 Significance and Use**

A2.3.1 This test method is intended to help assess the axial holding strength of various metallic bone staples used to fix either soft or hard tissue to bone. This information may be useful for comparisons of staple materials, designs, or placement under certain circumstances.

A2.3.2 This test method may not be appropriate for all types of bone staple applications. The user is cautioned to consider the appropriateness of the test method in view of the materials being tested and their potential application.

### **A2.4 Apparatus**

A2.4.1 *Testing Machines*, conforming to the requirements of Practices E 4. The loads used for determining strengths shall be within the loading range of the testing machine as defined in Practices E 4.

A2.4.2 *Gripping Devices*:

A2.4.2.1 *Hard Tissue Grips*—Grips designed specifically for secure grasping of bones, bone segments, or bone substitutes with minimal material effects at the staple fixation site during the application of tension to the metal or fabric strap. These grips must allow for variation in bone geometry and permit proper orientation and alignment of the bone (or substitute) during the test.

A2.4.2.2 *Metal or Fabric Strap Grips*—Grips designed for secure grasping of the metal or fabric strap with minimal damage during the application of tension. Typical grips may be actuated mechanically, pneumatically, or hydraulically to compress the strap between two flat grip faces parallel to the line of load application. The grip faces may be smooth or serrated.

A2.4.2.3 *Constant Temperature Bath*—An aqueous bath capable of maintaining the samples and containers at physiologic temperatures, 37 ± 2°C, for the specified testing periods.

### **A2.5 Test Specimen**

A2.5.1 *Staple*—A generally U-shaped metal loop, with at least two legs, that is driven into the surface of bone to either fix or immobilize adjacent pieces of bone or to fasten soft tissue or other material to bone. All test samples shall be representative of the material under evaluation. Samples for comparative tests shall be produced from the same material lot or batch and under the same fabricating conditions, unless noted specifically.

A2.5.2 *Staple Leg*—The parallel or nearly parallel extensions that are intended to penetrate the bone tissue; these may be round, square, or polygonal in cross section, and they may possess serrations or barbs to increase the fixation or purchase strength in the bone.

A2.5.3 *Staple Bridge*—The cross member of the staple connecting the legs; the bridge may be smooth or possess spikes or projections on the underside for the retention of soft tissue or other material.

A2.5.4 *Bone*—Fresh, fresh frozen, or preserved bone with material properties representative of the staple placement site; either cadaveric or animal bone may be suitable.

A2.5.5 *Bone Substitute*—A material with known, consistent properties, similar in strength, density, or rigidity to fresh, fresh frozen, or preserved bone. Substitutes such as natural wood, solid plastics, composites, or rigid foams may be suitable, depending on type, material properties, and configuration.

A2.5.6 *Metal or Fabric Tension Strap*—A thin, flat, flexible, highly conformable metal strip or fabric (woven or braided) that is used to apply a balanced lifting or pull-out force under the staple bridge. The strap should have a width sufficient to support 90 % of the staple bridge and have sufficient tensile properties so that it does not deform plastically or rupture under the applied loads.

A2.5.7 *Aqueous Solution*—Tap water, distilled water, physiological saline, or similar aqueous solutions, used to either maintain hydration of the soft tissue and bone used in the test or bathe or immerse the test specimens fully during the test.

**A2.6 Procedure**

A2.6.1 Prepare the staple fixation site(s) on the bone (or substitute); this may require predrilling to accommodate the staple legs without damage or fracture of the bone (or substitute).

A2.6.2 Insert and seat the staple in the bone (or substitute) in a standardized, repeatable manner using all appropriate surgical instrumentation specified by the manufacturer. The staple should be positioned over the tension strap, interposing the metal or fabric between the staple bridge and bone surface, leaving equal lengths of the strap on either side of the staple bridge. The strap should also be centered under the staple bridge, and the strap bulk should permit the staple to be seated against the bone fully. The staple bridge should be perpendicular to the long axis of the strap.

NOTE A2.1—In order to either reduce the inherent variability of manual staple insertion techniques or investigate the effects of deliberate variation of insertion parameters, it is permissible to devise special instrumentation in addition to that provided by the manufacturer. These additional instruments may be used to limit staple angulation, control insertion depth, or standardize insertion forces. However, any use of nonstandard surgical instrumentation for staple insertion must be described and reported fully.

A2.6.3 Record the insertion method (manual or mechanical), staple orientation, and position from known landmarks (if applicable).

A2.6.4 Fix the bone (or substitute) in the machine grips and align so that tension can be applied to the strap ends parallel to the staple legs. The bone should be gripped at a sufficient distance from the staple fixation site so that the fixation site is left undamaged and undisturbed (see the schematic of staple pull-out testing in Fig. A2.1).

A2.6.5 Grasp the ends of the strap, place them together, and secure them between the flat grip faces under equal tension (see Fig. A2.1).

NOTE A2.2—It is recommended that self-alignment devices such as universal joints, pin pivots, and so forth be placed in the load train in order to minimize the eccentric loading of either the tension strap or the staple.

A2.6.6 Apply load to the strap at a constant displacement, load, or strain rate.

A2.6.7 Monitor the load-displacement continuously until one of the test termination criteria is reached.

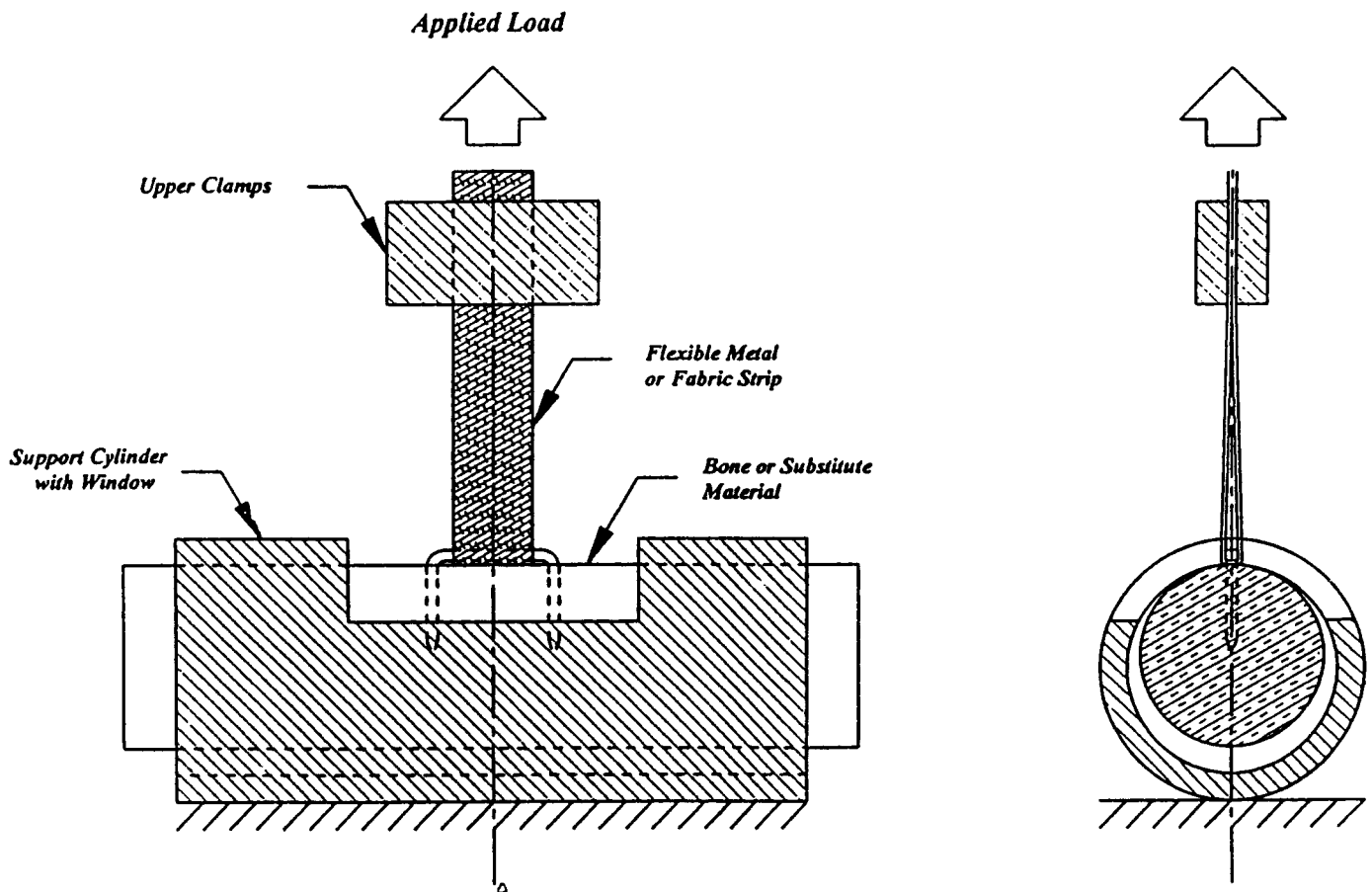

FIG. A2.1 Schematic of Staple Pull-Out Testing

NOTE A2.3—Elastic deformation in the strap may require a separate method of monitoring staple movement during the test.

## A2.7 Test Termination

A2.7.1 Testing of the samples shall be terminated when one or more of the following has occurred:

- A2.7.1.1 A significant drop in tensile load after peak,
- A2.7.1.2 Visible tearing or rupture of the strap (or substitute),
- A2.7.1.3 Fracture of the bone (or bone substitute), or
- A2.7.1.4 Loosening of the staple(s) or disruption of the staple-bone interface.

## A2.8 Report

A2.8.1 Report the following information:

A2.8.1.1 *Staple Description*—Type, size, special features (barbs, spikes, ~~etc.~~), and so forth, manufacturer, material, batch or lot number, and dimensions (including leg length, bridge width, and length), as appropriate.

A2.8.1.2 Fixation site and orientation (if applicable).

A2.8.1.3 Staple placement method, that is, manual or mechanical. Provide detail on the method used to insert the staples in a repeatable way.

A2.8.1.4 Speed of testing, that is, crosshead separation rate, load application rate, ~~etc.~~ and so forth.

A2.8.2 *Test Materials*:

A2.8.2.1 *Bone*—Species, location, type (cancellous or cortical), cortical thickness, and method of preservation (if applicable).

A2.8.2.2 *Bone Substitute*—Material, thickness, density, tensile or compressive mechanical properties (strength, stiffness, and so forth), grain direction, and so forth.

A2.8.2.3 *Strap*—Material, construction, tensile strength, and dimensions (width, thickness, and length).

A2.8.2.4 *Aqueous Solution (if used)*—Composition, temperature, and method of application.

A2.8.2.5 *Gage Length*—The minimum distance between the top of the staple bridge and lower end of the grip faces.

A2.8.2.6 Peak pull-out strength (average and standard deviation) or other fixation criteria (for example, load at the onset of defined staple movement), as deemed appropriate.

A2.8.2.7 Failure mode (pull-out of staple, rupture of strap, bone fracture, and so forth).

## A2.9 Precision

A2.9.1 Intralaboratory and interlaboratory reproducibility have not been determined systematically.

## A2.10 Rationale (Nonmandatory Information)

A2.10.1 This test method is intended to aid in determining the pull-out fixation strength of metallic bone staples used for the fixation of soft tissue to bone. Data obtained using this test method may be used to compare staple materials, design, or placement under certain circumstances.

A2.10.2 It is recognized that the use of substitute materials for bone may be necessary due to the practical limitations of obtaining sufficient suitable biological materials for comparing fixation strengths. Also, the inherent variability in biological materials makes the use of substitute materials preferable in some applications. However, in vitro testing, particularly with substitute materials, may not duplicate the in vivo behavior of implant devices adequately.

A2.10.3 The use of various tissue sources or synthetic substitutes is encouraged since this test method is intended to permit comparisons. Thus, the fixation of thinner, weaker tissue (for example, gracilis tendon) with a particular staple design may result in failure due to tearing or tissue rupture, while the use of the same staple to fix a thicker, stronger tissue (for example, patellar tendon) may produce a loss of fixation at higher loads due to staple movement. Similarly, the use of synthetic substitutes may highlight staple design differences, provide a useful measure of staple suitability to fix a substitute safely, or provide information regarding the staple seating depth versus fixation strength, and so forth.

# A3. TEST METHOD FOR SOFT TISSUE FIXATION STRENGTH OF METALLIC BONE STAPLES

## A3.1 Scope

A3.1.1 This test method covers testing the soft tissue fixation strength of metallic staples used in internal fixation of the musculoskeletal system. This test method may be used with physiologic soft tissue and bone or synthetic substitutes for either, or both. This test method may also be used when testing in an aqueous or physiological solution.

A3.1.2 The values stated in SI units are to be regarded as the standard.

A3.1.3 *This standard does not purport to address all of the safety concerns, if any, associated with its use. It is the responsibility of the user of this standard to establish appropriate safety and health practices and determine the applicability of regulatory limitations prior to use.*



### A3.2 Summary of Test Method

A3.2.1 Soft tissue, or a synthetic substitute, is fixed to bone (or a substitute) using single or multiple bone staples. Tension is applied to the soft tissue (or substitute) at a right angle to the plane of the staple legs until rupture or tearing of the soft tissue (or substitute) occurs or the staple purchase in the bone (or substitute) is disrupted. Tests using this test method may be conducted at ambient conditions or in aqueous or physiological solutions (either at room temperature or 37°C).

### A3.3 Significance and Use

A3.3.1 This test method is intended to help assess the tissue holding characteristics of various metallic bone staples used to fix soft tissue (tendons, ligaments, other grafts, ~~etc.~~ and so forth) to bone. This information may be useful for comparisons of staple materials, design, or placement under certain circumstances.

A3.3.2 This test method may not be appropriate for all types of bone staple applications. The user is cautioned to consider the appropriateness of the test method in view of the materials being tested and their potential application.

A3.3.3 *Measurement System*—Dimensions, loads, ~~etc.~~ and so forth shall be stated in SI units.

### A3.4 Apparatus

A3.4.1 *Testing Machines*, conforming to the requirements of Practices E 4. The loads used in determining strengths shall be within the loading range of the testing machine as defined in Practices E 4.

A3.4.2 *Gripping Devices*:

A3.4.2.1 *Hard Tissue Grips*—Grips designed specifically for secure grasping of bones, bone segments, or bone substitutes with minimal material effects at the staple fixation site during the application of tension to the soft tissue (or substitute). These grips must allow for variation in bone geometry and permit proper orientation and alignment of the bone (or substitute) during the test.

A3.4.2.2 *Soft Tissue Grips*—Grips designed specifically for secure grasping of soft tissue or a synthetic substitute in the proper orientation with minimal damage during the application of tension.

A3.4.3 *Constant Temperature Bath*—An aqueous bath capable of maintaining the samples and containers at physiologic temperatures,  $37 \pm 2^\circ\text{C}$ , for the specified testing periods.

### A3.5 Test Specimen

A3.5.1 *Staple*—A generally U-shaped metal loop, with at least two legs, that is driven into the surface of bone to either fix or immobilize adjacent pieces of bone or to fasten soft tissue or other material to bone. All test samples shall be representative of the material under evaluation. Samples for comparative tests shall be produced from the same material lot or batch and under the same fabricating conditions, unless noted specifically.

A3.5.2 *Staple Bridge*—The cross member of the staple connecting the legs; the bridge may be smooth or possess spikes or projections on the underside for the retention of soft tissue or other material.

A3.5.3 *Staple Leg*—The parallel or nearly parallel extensions that are intended to penetrate the bone tissue; these may be round, square, or polygonal in cross section, and they may possess serrations or barbs to increase the fixation or purchase strength in the bone.

A3.5.4 *Bone*—Fresh, fresh frozen, or preserved bone with material properties representative of the staple placement site; either cadaveric or animal bone may be suitable.

A3.5.5 *Bone Substitute*—A material with known, consistent properties, similar in strength, density, or rigidity to fresh, fresh frozen, or preserved bone. Substitutes such as natural wood, solid plastics, composites, or rigid foams may be suitable, depending on type, material properties, and configuration.

A3.5.6 *Soft Tissue*—Fresh, fresh frozen, or preserved soft tissue (ligament, tendon, ~~etc.~~ and so forth) representative of tissue affixed with staples; either cadaveric or animal tissue may be suitable.

A3.5.7 *Soft Tissue Substitute*—A material with known, consistent properties, similar in strength, stiffness, or behavior to fresh, fresh frozen, or preserved soft tissue. Suitable substitutes may be flat or round in cross section, consisting of either woven, twisted, or braided natural or synthetic fibers.

A3.5.8 *Aqueous Solution*—Tap water, distilled water, physiological saline, or similar aqueous solutions, used either to maintain hydration of the soft tissue and bone used in the test or to bathe or immerse the test specimens fully during the test.

### A3.6 Procedure

A3.6.1 Prepare the staple fixation site(s) on the bone (or substitute); predrilling in accordance with the manufacturer's recommendation may be required to accommodate the staple legs without damage or fracture to the bone.

A3.6.2 Insert and seat the staples in the bone (or substitute) in a standardized, repeatable manner using all appropriate surgical instrumentation specified by the manufacturer. The staples should be centered over the soft tissue or substitute, interposing them between the staple bridge and bone surface. Record the insertion method (manual or mechanical), distance between the staples (if applicable), staple orientation, and position from known landmarks (if applicable).

NOTE A3.1—In order to either reduce the inherent variability of manual staple insertion techniques or investigate the effects of deliberate variation of insertion parameters, it is permissible to devise special instrumentation in addition to that provided by the manufacturer. These additional instruments may

be used to limit or fix staple angulation, control insertion depth, or standardize insertion forces, provided that they do not alter the normal insertion mechanics substantially. Any use of nonstandard surgical instrumentation for staple insertion must be described and reported fully.

A3.6.3 Fix the bone (or substitute) in the machine grips and align so that tension can be applied to the soft tissue (or substitute) parallel to its long axis. Grip the bone or soft tissue a sufficient distance from the staple fixation site(s) so they are not damaged or disturbed (see Fig. A3.1).

NOTE A3.2—Failure of the bone or soft tissue (or their substitutes) at the interface with the grips shall not be considered a fixation failure.

A3.6.4 Apply load to the soft tissue (or substitute) at a constant displacement, load, or strain rate.

NOTE A3.3—It is recommended that self-alignment devices such as universal joints, pin pivots, etc. and so forth be placed in the load train in order to minimize eccentric loading of either the soft tissue or the staple.

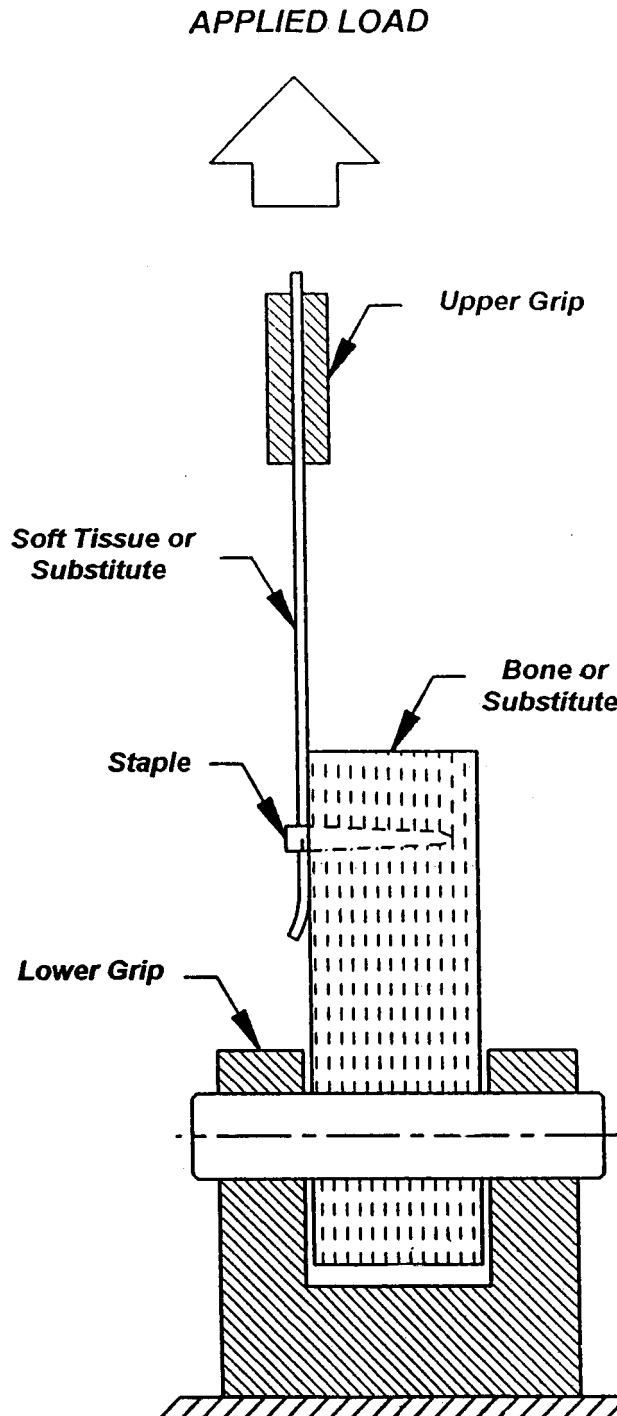

FIG. A3.1 Schematic of Tissue Fixation Strength Test

A3.6.5 Monitor the load-displacement continuously until one of the test termination criteria is reached.

### **A3.7 Test Termination**

A3.7.1 Testing of samples shall be terminated when one or more of the following has occurred:

- A3.7.1.1 A significant drop in tensile load after peak,
- A3.7.1.2 Visible tearing or rupture of the soft tissue (or substitute),
- A3.7.1.3 Slippage of the soft tissue from under the staple(s),
- A3.7.1.4 Fracture of the bone (or bone substitute), or
- A3.7.1.5 Loosening of the staple(s) or disruption of the staple-bone interface.

### **A3.8 Report**

A3.8.1 Report the following information:

A3.8.1.1 Staple type, size, special features (barbs, spikes, and so forth), manufacturer, material, batch or lot number, and dimensions (including leg length, bridge width, and length), as appropriate,

A3.8.1.2 Staple placement configuration (that is, single, double, belt-buckle, and so forth) and orientation (along length, across width, and so forth),

A3.8.1.3 Staple placement method, that is, manual or mechanical. Provide details on the method used to insert the staples in a repeatable way, and

A3.8.1.4 Speed of testing, that is, crosshead separation rate, load application rate, and so forth.

A3.8.2 *Test Materials*:

A3.8.2.1 *Bone*—Species, location, type (cancellous or cortical), cortical thickness, and method of preservation (if applicable).

A3.8.2.2 *Bone Substitute*—Material, thickness, density, tensile or compressive mechanical properties (strength, stiffness, and so forth), grain direction, and so forth.

A3.8.2.3 *Soft Tissue*—Species, tissue type (ligament, tendon, and so forth), dimensions (thickness, width, and so forth), and method of preservation (if applicable).

A3.8.2.4 *Soft Tissue Substitute*—Material, geometry (width, thickness, diameter, and so forth), tensile strength and stiffness, and construction (braided, woven, and so forth).

A3.8.2.5 *Aqueous Solution*—Composition, temperature, and method of application.

A3.8.2.6 Peak fixation strengths (average and standard deviation) or other fixation criteria (peak load at the onset of tissue slip, and so forth), as deemed appropriate.

A3.8.2.7 Failure mode (for example, onset of tissue slip, rupture of soft tissue or substitute, loosening of staple, and so forth).

### **A3.9 Precision**

A3.9.1 Intralaboratory and interlaboratory reproducibility has not been determined systematically.

### **A3.10 Rationale (Nonmandatory Information)**

A3.10.1 This test method is intended to aid in characterizing the mechanical behavior of metallic bone staples used for the fixation of soft tissue to bone. Data obtained using this test method may be used to compare staple materials, design, or placement under certain circumstances.

A3.10.2 It is recognized that the use of substitute materials for bone and soft tissue may be necessary due to the practical limitations of obtaining sufficient suitable biological materials for comparing fixation strengths. Also, the inherent variability in biological materials makes the use of substitute materials preferable in some applications. However, in vitro testing, particularly with substitute materials, may not duplicate the in vivo behavior of implant devices adequately.

A3.10.3 The use of various tissue sources or synthetic substitutes is encouraged since this test method is intended to permit comparisons. Thus, the fixation of thinner, weaker tissue (for example, gracilis tendon) with a particular staple design may result in failure due to tearing or tissue rupture, while the use of the same staple to fix a thicker, stronger tissue (for example, patellar tendon) may produce a loss of fixation at higher loads due to staple movement. Similarly, the use of synthetic substitutes may highlight staple design differences, provide a useful measure of staple suitability to fix a substitute safely, or provide information regarding the staple seating depth versus fixation strength, ~~etc.~~ and so forth.

A4. TEST METHOD FOR ELASTIC STATIC BENDING OF METALLIC BONE STAPLES<sup>5</sup>

A4.1 Scope

A4.1.1 This test method covers a procedure for determining the rigidity of bone staples.

A4.1.2 The values stated in either inch-pound or SI units are to be regarded separately as the standard. The units given in parentheses are for information only.

A4.1.3 *This standard does not purport to address all of the safety concerns, if any, associated with its use. It is the responsibility of the user of this standard to establish appropriate safety and health practices and determine the applicability of regulatory limitations prior to use.*

A4.2. Terminology

A4.2.1 Definitions:

A4.2.1.1 *staple, n*—a generally U-shaped metal loop, with at least two legs, that is driven into the surface of bone to either fix or immobilize adjacent bone pieces, or to fasten soft tissue or other material to bone.

A4.2.1.2 *staple bridge, n*—the cross member of the staple connecting the legs; these may be smooth or possess spikes or projections on the underside for retention of soft tissue or other material.

A4.2.1.3 *staple leg, n*—the parallel or nearly parallel extensions which are intended to penetrate the bone tissue; these may be round, square or polygonal in cross section, and may possess serrations or barbs to increase the fixation or purchase strength in the bone.

A4.3 Summary of Test Method

A4.3.1 This test method is based on a paper<sup>5</sup> that examined the bending rigidity of bone staples. The authors identified the initial slope of the bending curve as a parameter which could distinguish the staple stiffness from one staple to another. This parameter may be determined by placing each staple leg in a beam-like holder (see Fig. A4.1) and then bending the system in a four-point bending load apparatus (see Fig. A4.2). The applied force and displacement in the direction of the applied load will produce a bending curve from which the initial slope may be determined.

A4.4 Significance and Use

A4.4.1 This test method is intended to help assess the structural stiffness or rigidity of metallic bone staples for use in fixating or immobilizing bone or in fastening soft tissue or other material to bone. Under some circumstances, the test method may be of use in maintaining the batch uniformity of a test lot.

<sup>5</sup> Liberace, R., and Zvi L., "Mechanical Testing of Stainless Steel Bone Staples", *Journal of Testing and Evaluation*, Vol 20, No. 3, May 1992, pp. 217-224.

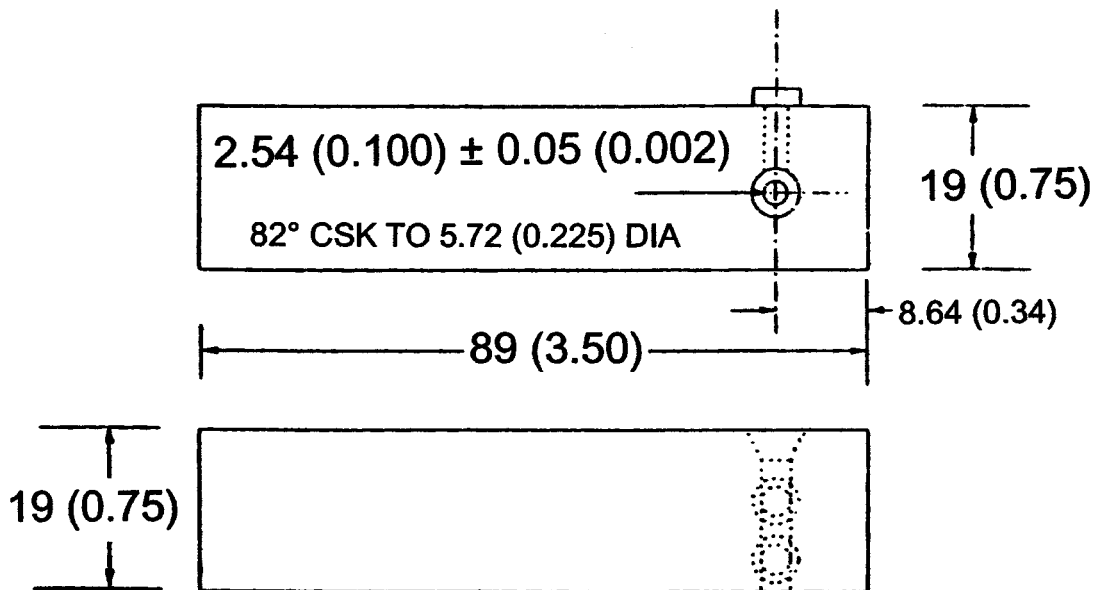

NOTE 1—All dimensions have a tolerance of 0.5 mm (0.02 in.) unless noted.

NOTE 2—Extension block as shown is for a 2.38 mm (3/32 in.) staple only; adjust dimensions accordingly.

FIG. A4.1 Staple Extension Block

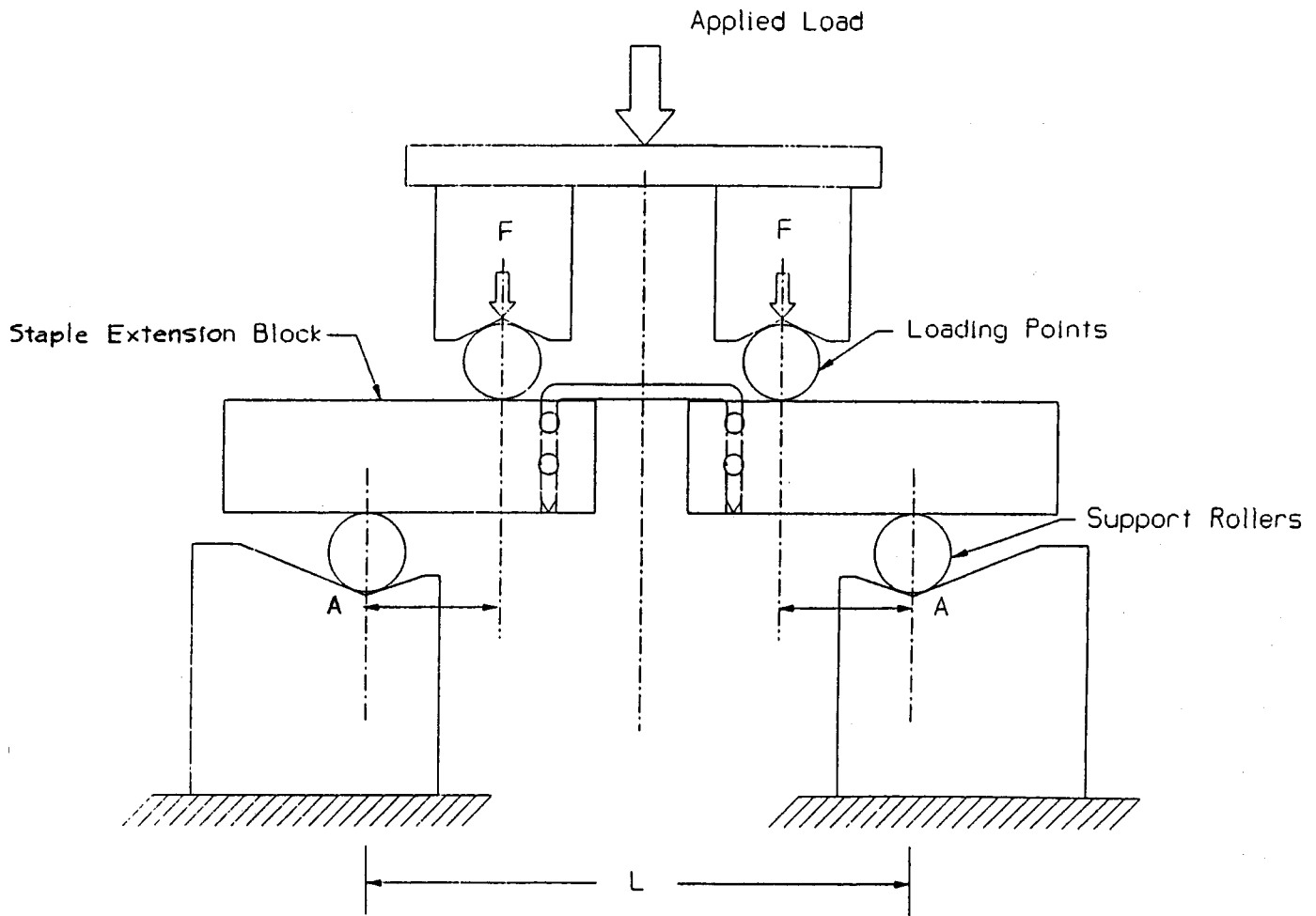

FIG. A4.2 Staple in Four-Point Bending Load Apparatus

#### A4.5 Apparatus

A4.5.1 *Testing Apparatus*—Figs. A4.1 and A4.2 show the test apparatus. Fig. A4.1 is a holder designed to hold one of the staple legs as the entire assembly is placed in a four-point bending load apparatus (see Fig. A4.2). The design in this figure is only a suggested type for a cylindrical wire type staple.

##### A4.5.2 *Staple Extension Blocks:*

A4.5.2.1 The staple extension blocks shown in Fig. A4.1 can be constructed of aluminum, steel, iron or any other metallic material. Each must be long enough to fit over the support roller bearings and be much stiffer than the staple. The dimensions shown in Fig. A4.1 are suitable, but not mandatory. Fig. A4.1 shows a system which can accommodate a  $\frac{3}{32}$  in. staple. When the staples are placed in the holders, each leg is held in place by two set screws on the side of the holder. When the staple is fully inserted into the holder, the underside of the staple bridge should contact the top surface of the staple extension block. For those staples that have stiffening webs, additional countersinking of the holding holes or the cutting of notches in the staple extension block may be necessary so that the bridge of the staple will fit in the extension blocks as shown in Fig. A4.2.

A4.5.2.2 Other holding systems may be used. However, each system should firmly fasten the legs of the staple so that bending occurs only at the bends in the staple and not in the staple legs. The system shown uses two set screws for this purpose. For other shaped staples, triangular, square, etc., and so forth, special holding blocks should be developed to custom fit the legs of the staples so that forces holding the staple legs are uniformly spread along the legs. For these staples an alternative holding procedure is to drill cylindrical holes large enough to accommodate the staple legs and then firmly cement the staple in place by using epoxy or some other agent. This procedure will eliminate the use of set screws that might produce uneven stresses upon the staple legs.

##### A4.5.3 *Four-Point Bending Fixture:*

A4.5.3.1 Fig. A4.2 shows the holders and a test staple placed in a four-point bending load apparatus. This apparatus is similar to that used in testing bone plates (see Test Method F 382):

$L$  = the horizontal length between the two lower rollers' centers, and

$A$  = the horizontal distance between upper and lower rollers' centers.

A4.5.3.2 The lower supports consist of two rollers,  $L = 120$  mm (4.7 in.) apart and the upper loading apparatus has rollers placed 40 mm (1.57 in.) apart, which are one-third the distance from the lower support, so that all loads shall be equally supported by

the rollers. Thus, the horizontal distance, *A*, between the centers of the upper and lower rollers will also be 40 mm (1.57 in.). The direction of the applied load shall be restricted to that shown in Fig. A4.2. All rollers should be well lubricated and have diameters of 12.5 mm (0.50 in.). The applied force and crosshead or actuator displacement should be measured by instruments suitable for bending tests that conform to Practices E 4.

**A4.6 Sampling**

A4.6.1 Representative random samples may be taken from each processing quantity in accordance with Practice E 122.

**A4.7 Procedure**

*A4.7.1 Measuring Testing Machine Compliance:*

A4.7.1.1 Before any staples are analyzed, the overall deflection produced by applying force to the test system must be examined. Deflection under load of the four-point bending fixtures, staple extension, ~~etc.,~~ and so forth, should be determined experimentally. The deflections in the test fixtures can be neglected if the compliance of the staple extension blocks and other parts of the test system are less than 2 % of the measured compliance of the staples and fixtures.

A4.7.1.2 A suggested means for estimating deflections in the test system alone is as follows: fabricate a single one-piece block of the same width and depth of the staple extension blocks and of a length sufficient to span beyond the two lower support rollers. The compliance of the test system alone can then be determined from the inverse of the initial slope of a plot of applied force versus crosshead or actuator displacement. A measurement of this quantity should then be obtained employing each distinct type of staple tested inserted in the extension blocks. If the ratios of compliances of the former test system to the latter test systems with staples are all less than 2 %, the compliance of the test fixtures can be neglected. Otherwise, compensation for measured fixture deflections should be made in the staple bending curves, or the staple extension blocks should be refabricated from a stiffer grade or type of metal.

*A4.7.2 Testing Procedures:*

A4.7.2.1 Place the staple in the extension blocks and in the four-point bending load apparatus as shown in Fig. A4.2.

A4.7.2.2 Apply a load to the staple at a constant displacement rate of ~~1 in./min (25.4 mm/min)~~ 25.4 mm/min (1 in./min) and measure the crosshead or actuator displacement.

A4.7.2.3 Plot the applied load versus the crosshead or actuator displacement (as in Fig. A4.3).

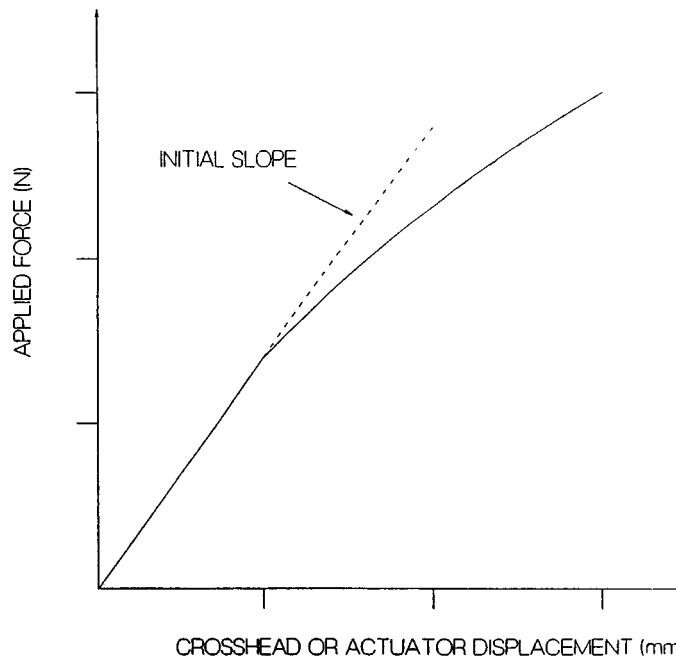

**FIG. A4.3 Typical Load-Deflection Curve for Bone Staple in Four-Point Bending**

A4.7.2.4 The point at which the crosshead or actuator displacement should be stopped is determined by the operator’s judgment. The only guides are:

A4.7.2.5 A sufficient length of curve must be developed so that a suitable tangent to the initial portion of the curve can be drawn; and

A4.7.2.6 No damage to the test fixture should occur.

A4.7.2.7 Calculate staple stiffness by measuring the initial slope of the load-displacement curve and report the result in N/mm (lb/in.).

#### **A4.8 Report**

A4.8.1 All standard units for reporting results from this test method shall be in SI units.

A4.8.2 Report the following information:

A4.8.2.1 The staple description shall conform to those measurable quantities and descriptions stated in Specification F 564. For those staples which cannot be described by the procedure in Specification F 564, a drawing of the staples shall be furnished;

A4.8.2.2 Material of composition;

A4.8.2.3 Dimensions of the test apparatus and staple extension blocks, if different from that specified in 4.2 and 4.3;

A4.8.2.4 The number of test specimens;

A4.8.2.5 Mean and standard deviation of the slope of the bending curve; and

A4.8.2.6 Manufacturer, part number, and lot number if available.

#### **A4.9 Precision and Bias**

A4.9.1 Data establishing the precision and bias to be expected from this test method have not yet been obtained.

#### **A4.10 Rationale (Nonmandatory Information)**

A4.10.1 This test method provides a procedure that can measure the structural stiffness or rigidity of the staple. This property is an indication to the user of the relative stiffness of the staple from which the user can compare one staple with another.

*ASTM International takes no position respecting the validity of any patent rights asserted in connection with any item mentioned in this standard. Users of this standard are expressly advised that determination of the validity of any such patent rights, and the risk of infringement of such rights, are entirely their own responsibility.*

*This standard is subject to revision at any time by the responsible technical committee and must be reviewed every five years and if not revised, either reapproved or withdrawn. Your comments are invited either for revision of this standard or for additional standards and should be addressed to ASTM International Headquarters. Your comments will receive careful consideration at a meeting of the responsible technical committee, which you may attend. If you feel that your comments have not received a fair hearing you should make your views known to the ASTM Committee on Standards, at the address shown below.*

*This standard is copyrighted by ASTM International, 100 Barr Harbor Drive, PO Box C700, West Conshohocken, PA 19428-2959, United States. Individual reprints (single or multiple copies) of this standard may be obtained by contacting ASTM at the above address or at 610-832-9585 (phone), 610-832-9555 (fax), or service@astm.org (e-mail); or through the ASTM website (www.astm.org).*