



Standard Specification for Thermocouple Connectors¹

This standard is issued under the fixed designation E 1129/E 1129M; the number immediately following the designation indicates the year of original adoption or, in the case of revision, the year of last revision. A number in parentheses indicates the year of last reapproval. A superscript epsilon (ϵ) indicates an editorial change since the last revision or reapproval.

1. Scope

1.1 This specification covers separable single-circuit thermocouple connectors with two round pins. Connectors covered by this specification must be rated for continuous use to at least 300 °F (150 °C), but they may optionally be rated higher.

1.2 This specification does not cover multiple-circuit connectors, multi-pin connectors, miniature connectors, or connectors intended primarily for panel mounting. High temperature connectors (for example, those designed for continuous use at temperatures above approximately 500 °F (260 °C)) are not intended to be covered by this specification.

1.3 The values stated in either inch-pound units or SI units are to be regarded separately as standard.

1.4 The following precautionary statement pertains only to the test method portion, Section 9, of this specification. *This standard does not purport to address all of the safety concerns, if any, associated with its use. It is the responsibility of the user of this standard to establish appropriate safety and health practices and determine the applicability of regulatory limitations prior to use.*

2. Referenced Documents

2.1 The following documents of the latest issue form a part of this specification to the extent referenced herein. In case of conflict between this specification and another referenced document, this specification shall take precedence.

2.2 ASTM Standards:

E 230 Specification and Temperature-Electromotive Force (EMF) Tables for Standardized Thermocouples²

E 344 Terminology Relating to Thermometry and Hydrometry²

E 608 Specification for Mineral-Insulated, Metal-Sheathed Base-Metal Thermocouples²

3. Terminology

3.1 *Definitions:* The definitions given in Terminology E 344 shall apply.

¹ This specification is under the jurisdiction of ASTM Committee E20 on Temperature Measurement and is the direct responsibility of Subcommittee E20.04 on Thermocouples.

Current edition approved Oct. 10, 2002. Published May 2003. Originally approved in 1986. Last previous edition approved in 1998 as E 1129 – 98.

² *Annual Book of ASTM Standards*, Vol 14.03.

3.2 Definitions of Terms Specific to This Standard:

3.2.1 *connector pair, n*—an assembly consisting of a plug and a jack, each having both positive and negative inserts, that will connect two parts of an electrical circuit and provide a means of physically disconnecting the two parts without the use of tools.

3.2.2 *contact insert, n*—metallic conductor assemblies that, when installed in connector bodies, provide connections between two parts of an electrical circuit. Plug connectors will contain projecting prong contacts, while jack connectors will contain recessed socket or receptacle contacts.

3.2.3 *service life, n*—interval of time that a connector assembly will be put to use and retain all physical and thermoelectric properties.

3.2.4 *test difference, n*—apparent thermoelectric difference attributable to mated connectors observed by the test procedure of this specification.

4. Significance and Use

4.1 The widespread use of thermocouple connectors requires standardization of mating dimensions and performance characteristics.

4.2 This specification describes standardized thermocouple connector dimensions and capabilities and includes test procedures suitable for evaluating the performance of a particular specimen or design. The tests described are not intended for routine inspection or rapid testing of large groups of connectors or for quality control purposes.

5. Classification

5.1 Plugs or Jacks:

5.1.1 Connectors shall be constructed as either plugs or jacks, and these two forms shall be designed to connect with each other.

5.1.2 Plug connectors shall have two external prong contacts of differing diameters to prevent improper mating. The negative prong shall be the larger, as shown in Table 1 and Fig. 1.

5.1.3 Jack connectors shall have two internal socket contacts sized and spaced to receive and accommodate the prong contacts of the mating plug. Jack connectors shall also include a means of producing and maintaining sufficient contact pressure to meet all of the other requirements of this specification.

TABLE 1 Dimensions

Dimension	Symbol ^A	Minimum, in. (mm)	Maximum, in. (mm)
Body length	L	...	1.505 (38.23)
Body width	W	...	1.088 (27.64)
Body thickness	T	...	0.515 (13.08)
Length of prong	P	0.535 (13.59)	0.650 (16.51)
Depth of socket	J	0.650 (16.51)	...
Prong spacing	X	0.432 (10.97)	0.442 (11.23)
Positive pin diameter	D1	0.152 (3.86)	0.158 (4.02)
Negative pin diameter	D2	0.182 (4.62)	0.190 (4.83)
Location of detent	E	0.180 (4.57)	0.200 (5.08)
Width of detent	G	0.040 (1.02)	...
Depth of detent	F	0.010 (0.25)	0.025 (0.64)

^A Symbols are according to Fig. 1.

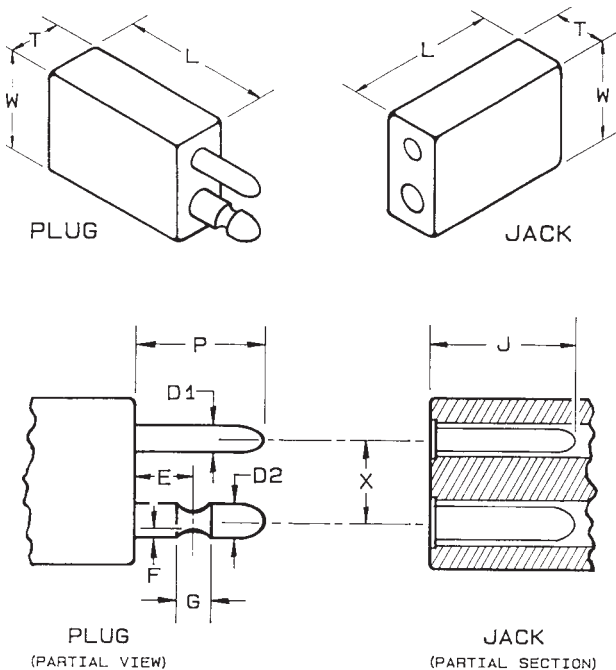

NOTE—A solid prong is shown for clarity of design.

FIG. 1 Thermocouple Connector Dimensions, (see Table 1)

5.2 ANSI/ASTM Type:

5.2.1 Connectors shall be produced in versions to match each of the standardized ANSI/ASTM thermocouple types as given in Table 2.

TABLE 2 Identification

ANSI/ASTM Type	Body Color Coding
T	Blue
J	Black
E	Purple
K	Yellow
N	Orange
R or S	Green
B (Cu/Cu) ^A	White

^A Uncompensated (Cu/CU) connectors are customarily used with Type B thermocouples.

5.2.2 The insert materials of each plug and jack shall have thermoelectric properties conforming to the characteristics of the corresponding thermocouple type as given in Specification E 230 over the temperature range specified in Table 3.

5.2.3 Calibration conformance and gradient testing is not applicable to Type B thermoelectrically neutral (Cu/Cu) connectors.

6. Ordering Information

6.1 Orders for connectors under this specification shall include the following:

6.1.1 Quantity of plugs or jacks (specify which),

6.1.2 ANSI/ASTM thermocouple type (see Table 2),

6.1.3 Any optional accessories that may be required, such as those listed in 7.4.3,

6.1.4 Special testing requirements, and

6.1.5 Requirements for certificates of conformance to the specifications or reports of the results of any required testing.

7. Materials and Manufacture

7.1 Body:

7.1.1 The dimensions of the connector bodies shall fall within the limits given in Table 1.

7.1.2 The connector body shall be made of an electrically insulating material capable of continuous use at any temperature between 0 °F (-18 °C) and 300 °F (150 °C) for the service life given in Table 3, without losing its ability to conform to this specification.

7.1.3 The connector bodies shall be colored in accordance with the color code given in Table 2 to provide rapid and permanent identification of the thermocouple calibration with which it is designed to be used. Each plug and jack shall be permanently marked with a symbol or symbols to identify positive and negative conductor inserts. All connectors shall bear the supplier's name or other means of source identification, unless otherwise specified in the purchasing documents.

7.1.4 An insulating barrier shall be incorporated into each connector body to prevent inadvertent contact between thermoelements or wires.

7.2 Inserts:

7.2.1 Contact inserts may be either solid or hollow as long as all of the requirements of this specification are met.

TABLE 3 Ratings

Characteristic	min	max
Operating temperature	0 °F (-18 °C)	300 °F (-150 °C)
Insertion force	6 lb (27 N)	18 lb (80 N)
Withdrawal force	6 lb (27 N)	18 lb (80 N)
Contact resistance (each leg)	...	0.04 ohms
Insulation resistance	...	10 ⁷ ohms
Test difference	...	±2 °F (±1.1 °C)
Repeated cycles (coupled or uncoupled)	25	...
Service life	5000 h	...

7.2.2 Contact inserts shall be fabricated of materials that meet the requirements of Section 5.

7.2.3 The inside diameter and depth of the jack connector shall be such as to receive the corresponding plug prong smoothly and easily when inserted. A spring loaded detent device shall be incorporated in the negative side of the jack connector to engage the detent in the negative plug prong. The function of the detent system shall be to cause positive locking together of a plug and jack when fully mated. The detent system shall not permit the two connectors to be separated by more than 0.03 in. (0.8 mm) when subjected to a withdrawal force less than the minimum given in Table 3.

7.2.4 The forces required for complete engagement or disengagement shall be within the limits listed in Table 3.

7.2.5 The connector pair shall be capable of repeated insertion and withdrawal cycles as given in Table 3 without losing the ability to conform to the requirements of this specification.

7.2.6 The dimensions and locations of the inserts in the connector bodies shall fall within the limits given in Table 1.

7.3 Construction and Assembly:

7.3.1 Wire attachment shall be by means of a screw or clamp suitable for use with wire diameters from 30 AWG (0.01 in. or 0.25 mm in diameter) to 18 AWG (0.04 in. or 1.0 mm in diameter).

7.3.2 Contact inserts and wire attaching parts shall be held captive to one of the body parts.

7.3.3 Connections and final closures of the connector shall be accomplished with simple hand tools such as screwdrivers, wrenches, or pliers.

7.4 Optional Accessories:

7.4.1 Connector accessories are not covered by this specification and may be unique to a manufacturer's specific design.

7.4.2 All required optional accessories are to be specified separately from the connectors.

7.4.3 The following is a partial list of useful accessory items:

7.4.3.1 Cable clamping devices, for attaching flexible cables;

7.4.3.2 Clamps for rigid tubing and sheaths in a range of diameters as listed in Specification E 608;

7.4.3.3 Elastomeric boots to seal connector assemblies against moisture in service;

7.4.3.4 Safety clamps or other devices to prevent inadvertent separation of connectors under conditions of severe vibration; and

7.4.3.5 Flat washers for use under wire attachment screw heads as an aid in the retention of the wires.

7.4.4 Some suppliers may not offer all of the above items while others may offer additional items. Supplier catalogs and literature should be consulted for details.

8. Physical Properties

8.1 The physical size of connectors conforming to this specification shall fall within the limits given in Table 1 for all dimensions indicated in that table. All other dimensions and all details of construction shall be determined by a manufacturer's specific design.

9. Test Methods

9.1 Contact Resistance Test:

9.1.1 A direct current of 1.0 A from a constant current source shall be passed through one half (for example, the positive leg) of a mated connector pair. The voltage drop across that leg of the mated pair shall be measured and recorded. The procedure shall be repeated on the same leg of the mated connector pair but with reversed polarity. The average of the two measured voltage drops shall be calculated to eliminate thermoelectrical effects. The contact resistance in ohms is then computed by dividing the average drop in volts by the current in amperes.

9.1.2 The entire procedure of 9.1.1 is then repeated for the other half (negative leg) of the mated connector pair.

9.1.3 The contact resistance value for each leg must be within the limit given in Table 3.

9.1.4 Alternate test methods may be used if agreeable to both the supplier and the purchaser. In such event, the test method to be used shall be identified.

9.2 Thermal Gradient Test:

9.2.1 Apparatus:

9.2.1.1 *Heated Chamber*, obtain or construct a chamber made of suitable heat resisting materials. Use Fig. 2 as a general guide for construction. A controlled heat source other than light bulbs may be used.

9.2.1.2 *Test Panel*, fabricated and fitted similar to that shown in Fig. 2. The small, removable, central panel through which the plug and jack are mated should be made of electrically insulating, heat-resistant material not more than about 0.032 in. (0.8 mm) thick. This central panel should be somewhat larger than the outside dimensions of the connectors to be tested. The panel is pierced with two clearance holes through which the connector prongs pass during the test. A third hole is provided alongside the connector location through which a single length of duplex thermocouple wire can pass.

9.2.2 Test Specimen Preparation:

9.2.2.1 For uniformity of test results, use 24 AWG (0.020 in. or 0.5 mm diameter) thermocouple wire or extension wire of the type corresponding to the connector to be tested. Larger diameter wire will produce higher values of measured test difference, while smaller diameter wire will produce lower values.

9.2.2.2 Cut (in half) a continuous length of appropriate duplex thermocouple wire. Strip all cut ends. Form a single junction by welding four conductors at one end into a common bead. Cut one of the two wire lengths at a distance of 4 to 6 in. (10 to 15 cm) from the junction bead. Strip these newly cut ends and connect the jack connector being tested to the short wire length extending from the weld bead. Then connect the separated segment of wire to the plug connector being tested, as shown in Fig. 3.

9.2.2.3 Assemble the connectors in the removable test panel by pushing the plug prongs through two holes in the test panel and mating the jack to it as shown in Fig. 2. Pass the uncut length of wire from the junction bead through the third hole in the test panel.

9.2.3 Test Procedure:

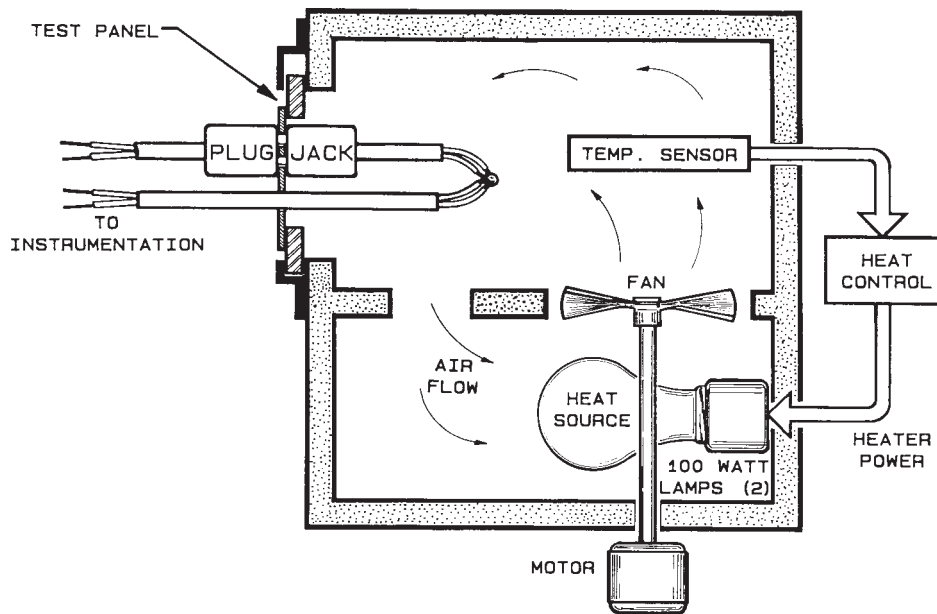

FIG. 2 General Arrangement for Thermal Gradient Test

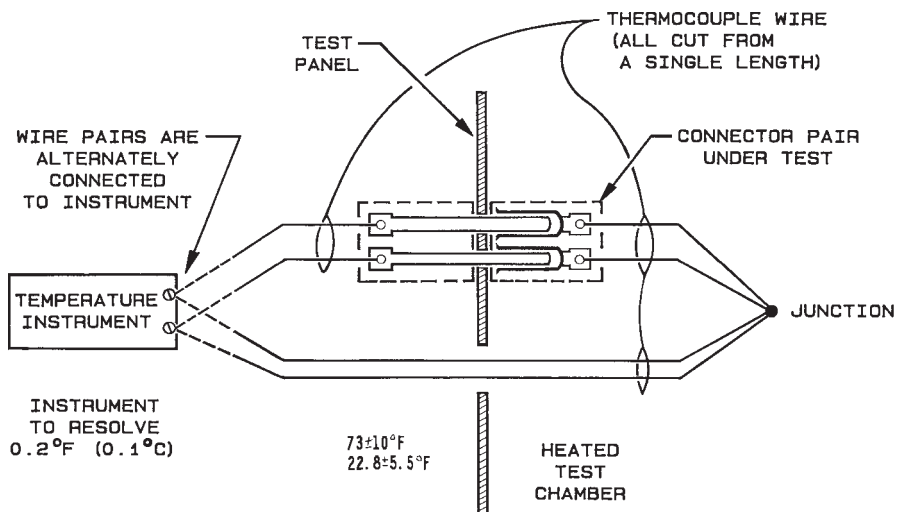

FIG. 3 Test Circuit for Thermal Gradient Test

9.2.3.1 Install the test panel containing the previously wired connectors in an opening in the test chamber so that the junction bead and jack connector are inside the heated chamber as shown in Fig. 2. Stabilize the test chamber at $150 \pm 10^\circ\text{F}$ ($65 \pm 5^\circ\text{C}$) and allow the system to reach thermal equilibrium.

9.2.3.2 Connect an instrument capable of resolving 0.2°F (0.1°C) or less, to the wire pair passing through the hole in the test panel. Measure and record the chamber temperature. Reconnect the instrument to the wire pair extending from the connector plug under test. Measure and record the new reading. The difference between the first reading, taken directly, and the second, taken through the connector pair under test, is the test difference.

9.2.3.3 The test difference expresses quantitatively the effect of the connector pair's presence in the circuit under the test

conditions. The test difference shall not be greater than the value given in Table 3 for qualification under this specification.

NOTE 1—The test difference plus the thermocouple wire error must be combined to determine total error in a thermocouple circuit under these test conditions.

9.3 Insulation Resistance Test:

9.3.1 Insulation resistance between legs shall be measured with a megohm meter using a voltage between 25 and 100 Vdc. The measured resistance shall not be less than the value given in Table 3 when tested at any temperature within the rated range.

9.3.2 The insulation resistance between each leg and any other exposed metallic part or electrically conducting portion of a thermocouple connector assembly, including fasteners,



shall not be less than the value given in Table 3 when tested in a manner similar to 9.3.1.

10. Rejection

10.1 Material that fails to conform to the requirements of this specification may be rejected.

11. Keywords

11.1 connector; contact inserts; jack; plug; quick disconnect; thermocouple; thermocouple connector; thermocouple quick disconnect

ASTM International takes no position respecting the validity of any patent rights asserted in connection with any item mentioned in this standard. Users of this standard are expressly advised that determination of the validity of any such patent rights, and the risk of infringement of such rights, are entirely their own responsibility.

This standard is subject to revision at any time by the responsible technical committee and must be reviewed every five years and if not revised, either reapproved or withdrawn. Your comments are invited either for revision of this standard or for additional standards and should be addressed to ASTM International Headquarters. Your comments will receive careful consideration at a meeting of the responsible technical committee, which you may attend. If you feel that your comments have not received a fair hearing you should make your views known to the ASTM Committee on Standards, at the address shown below.

This standard is copyrighted by ASTM International, 100 Barr Harbor Drive, PO Box C700, West Conshohocken, PA 19428-2959, United States. Individual reprints (single or multiple copies) of this standard may be obtained by contacting ASTM at the above address or at 610-832-9585 (phone), 610-832-9555 (fax), or service@astm.org (e-mail); or through the ASTM website (www.astm.org).