



Standard Specification for Thermocouples, Sheathed, Type K and Type N, for Nuclear or for Other High-Reliability Applications¹

This standard is issued under the fixed designation E 235; the number immediately following the designation indicates the year of original adoption or, in the case of revision, the year of last revision. A number in parentheses indicates the year of last reapproval. A superscript epsilon (ϵ) indicates an editorial change since the last revision or reapproval.

1. Scope

1.1 This specification covers the requirements for sheathed, Type K and N thermocouples for nuclear service. Depending on size, these thermocouples are normally suitable for operating temperatures to 1652 °F (900 °C); special conditions of environment and life expectancy may permit their use at temperatures in excess of 2012 °F (1100 °C). This specification was prepared specifically to detail requirements for using this type of sheathed thermocouple in nuclear environments. This specification can be used for sheathed thermocouples which are required for laboratory or general commercial applications where the environmental conditions exceed normal service requirements. The intended use of a sheathed thermocouple in a specific nuclear application will require evaluation by the purchaser of the compatibility of the thermocouple, including the effect of the temperature, atmosphere, and integrated neutron flux on the materials and accuracy of the thermoelements in the proposed application. This specification does not attempt to include all possible specifications, standards, etc., for materials that may be used as sheathing, insulation, and thermocouple wires for sheathed-type construction. The requirements of this specification include only the austenitic stainless steels and other alloys as allowed with Specification E 585/E 585M for sheathing, magnesium oxide or aluminum oxide as insulation, and Type K and N thermocouple wires for thermoelements (see Note 1).

1.2 *General Design*—Nominal sizes of the finished thermocouples shall be 0.0400 in. (1.016 mm), 0.0625 in. (1.588 mm), 0.125 in. (3.175 mm), 0.1875 in. (4.763 mm), or 0.250 in. (6.350 mm). Sheath dimensions and tolerances for each nominal size shall be in accordance with Table 1. The classes of thermocouples covered by this specification are as follows:

1.2.1 *Class 1 (grounded)*—Measuring junction electrically connected to conductive sheaths, and

1.2.2 *Class 2 (ungrounded)*—Measuring junctions are electrically isolated from conductive sheaths and from reference ground.

1.3 The values stated in inch-pound units are to be regarded as the standard. The values given in parentheses are for information only.

1.4 *This standard does not purport to address all of the safety concerns, if any, associated with its use. It is the responsibility of the user of this standard to establish appropriate safety and health practices and determine the applicability of regulatory limitations prior to use.*

2. Referenced Documents

2.1 ASTM Standards:²

- A 262 Practices for Detecting Susceptibility to Intergranular Attack in Austenitic Stainless Steels
- E 3 Practice for Preparation of Metallographic Specimens
- E 45 Test Methods for Determining the Inclusion Content of Steel
- E 94 Guide for Radiographic Examination
- E 112 Test Methods for Determining Average Grain Size
- E 165 Test Method for Liquid Penetrant Examination
- E 220 Test Method for Calibration of Thermocouples by Comparison Techniques
- E 230 Specification for Temperature-Electromotive Force (EMF) Tables for Standardized Thermocouples
- E 344 Terminology Relating to Thermometry and Hydrometry
- E 585/E 585M Specification for Compacted Mineral-Insulated, Metal-Sheathed, Base Metal Thermocouple Cable
- E 780 Test Method for Measuring the Insulation Resistance of Sheathed Thermocouple Material at Room Temperature
- E 839 Test Methods for Sheathed Thermocouples and Sheathed Thermocouple Material
- E 883 Guide for Reflected-Light Photomicrography
- E 1652 Specification for Magnesium Oxide and Aluminum Oxide Powder and Crushable Insulators Used in the Manufacture of Metal-Sheathed Platinum Resistance Thermometers, Base Metal Thermocouples, and Noble Metal Thermocouples

¹ This specification is under the jurisdiction of ASTM Committee E20 on Temperature Measurement and is the direct responsibility of Subcommittee E20.04 on Thermocouples.

Current edition approved Nov. 1, 2003. Published January 2004. Originally approved in 1964. Last previous edition approved in 1996 as E 235 – 88 (1996) ^{ϵ 1}.

² For referenced ASTM standards, visit the ASTM website, www.astm.org, or contact ASTM Customer Service at service@astm.org. For *Annual Book of ASTM Standards* volume information, refer to the standard's Document Summary page on the ASTM website.

TABLE 1 Dimensions for Class 1 and 2 Measuring Junctions

Nominal	Sheath Outside Diameter, A		Minimum Sheath Wall, B	Minimum Insulation Thickness, C	Minimum Wire Diameter, D	E, Tolerance		F, Tolerance	
	Tolerance					min	max	min	max
	min	max							
Inches									
0.0400	0.0390	0.0415	0.006	0.004	0.005	0.006	0.020	0.004	0.021
0.0625	0.0615	0.0640	0.009	0.005	0.010	0.009	0.032	0.005	0.032
0.1250	0.1240	0.1265	0.012	0.012	0.020	0.012	0.062	0.012	0.063
0.1875	0.1865	0.1890	0.020	0.022	0.031	0.020	0.093	0.022	0.095
0.2500	0.2480	0.2520	0.030	0.024	0.040	0.030	0.125	0.024	0.125
Millimetres									
1.016	0.991	1.054	0.15	0.10	0.13	0.15	0.51	0.10	0.53
1.588	1.562	1.626	0.23	0.13	0.25	0.23	0.81	0.13	0.81
3.175	3.150	3.213	0.30	0.30	0.51	0.30	1.57	0.30	1.60
4.763	4.737	4.801	0.51	0.56	0.79	0.51	2.36	0.56	2.41
6.350	6.299	6.401	0.76	0.61	1.02	0.76	3.18	0.61	3.18

2.2 ANSI Standard:

B46.1 Surface Texture³

2.3 American Welding Society Standard:

A5.9 Specification for Corrosion-Resisting Chromium and Chromium-Nickel Steel-Welding Rods and Bare Electrodes⁴

3. Terminology

3.1 The definitions given in Terminology E 344 shall apply to this specification.

4. Ordering Information and Basis of Purchase

4.1 The purchase order documents shall specify the following information:

4.1.1 The quantity, length, and nominal diameter of the sheathed thermocouple,

4.1.2 The thermocouple type and tolerance on initial values of emf versus temperature, if other than standard (see Specification E 230),

4.1.3 The type of ceramic insulation required, either alumina (Al₂O₃) or magnesia (MgO),

4.1.4 The type of sheath material and other information required (see 5.1.1),

4.1.5 The class of thermocouple measuring junction,

4.1.6 The type of dye-penetrant inspection procedure to be used, and

4.1.7 Any deviations from this specification or the referenced specifications.

5. Materials and Manufacture

5.1 All materials used shall be in accordance with the following requirements:

5.1.1 *Sheath Materials*—The sheath material used for the thermocouples described in this specification must meet the requirements of Specification E 585/E 585M. The purchaser of the thermocouples shall specify only the name of the material

(seamless or welded), grade, optional requirements, test report required, and ASTM designation.

5.1.1.1 The inclusion level of the tubing shall be determined by mounting a 1-in. minimum length of a longitudinal section of the tubing using Test Methods E 45, Microscopical Method A, for examination. The inclusion level shall be less than 3 A through D, thin or heavy.

5.1.1.2 The grain size of the tubing shall be determined by a specimen taken in accordance with Test Methods E 112. Grain size shall be as specified in Table 2, or finer, as determined by the Comparison Procedure of Test Methods E 112.

5.1.1.3 Each lot of tubing used shall be sampled using Practices A 262 as follows. Samples shall be tested by Practice A, and further tested as outlined by Table 1 in Practices A 262, where screening tests so indicate. Acceptance levels for these tests shall be agreed upon between the purchaser and the producer.

5.1.2 *Thermoelement*—Thermoelements referred to in this specification shall be Type K or Type N with a tolerance on initial values of emf versus temperature specified if other than standard.

NOTE 1—The purchaser may specify an alternative type of thermoelement as designated in Specification E 230 by indicating this deviation in the ordering documents.

5.1.3 *Insulation*—The insulating material shall be either magnesia (MgO) or alumina (Al₂O₃) and shall comply with Specification E 1652 Type 1 material requirements:

5.1.3.1 A certified analysis of the composition of the insulating material as supplied to the thermocouple manufacturer shall be furnished to the purchaser. The thermocouple manufacturer shall be responsible for maintaining the purity within the specified limits in the finished product.

TABLE 2 Maximum Grain Sizes

Sheath Outside Diameter, in. (mm)	Maximum
0.0400 (1.016)	6
0.0625 (1.588)	5
0.1250 (3.175)	
0.1875 (4.763)	
0.2500 (6.35)	

³ Available from American National Standards Institute (ANSI), 25 W. 43rd St., 4th Floor, New York, NY 10036.

⁴ Available from The American Welding Society (AWS), 550 NW LeJeune Rd., Miami, FL 33126.

5.1.4 *Welding Rod*—Filler rod material used for welding on the sheath or thermocouple closures shall comply with the requirements of AWS Specification A 5.9 for the tubing material specified on the ordering documents.

5.2 *Processing:*

5.2.1 *Cleanliness*—The surface of the completed thermocouples at the time of delivery shall be free of residues containing nuclear poisons, such as boron and cadmium compounds, or foreign substances, such as chlorine compounds, strong acids, bases, oils, greases, or dust that could become the source of corrosion or chemistry changes in a primary coolant or heat-transfer medium. The use of compounds containing halogens is prohibited for final cleaning. Alcohol, or methyl isobutyl ketone may be used unless otherwise specified.

5.2.2 *Annealing*—The sheath of the finished thermocouple shall be solution annealed and shall not be sensitized.

6. Inspection and Test Methods

6.1 *General Procedure*—Inspect and approve all thermocouples in accordance with the sampling procedures specified in this section and with inspection requirements stated herein and in referenced specifications. Acceptance of the sample inspection results does not relieve the thermocouple manufacturer of the responsibility that all thermocouples shall conform to all requirements of this specification and the latest issue of the referenced specifications.

6.1.1 Acceptance of thermocouples manufactured in accordance with this specification requires the satisfactory completion of the general tests specified for all thermocouples and two additional tests on selected sample thermocouples.

6.1.2 Select a sample thermocouple at random from each “lot” of thermocouples. A “lot” of thermocouples is defined as a group of not more than 15 thermocouples, manufactured from the same materials in the same production run. Use a section of the sample thermocouple for the tests required in 6.7 and 6.10.2. For the test in 6.10.2, fabricate a measuring junction of the same class as that in the original “lot.” Inspection and testing of this measuring junction, such as that in 6.3, is not required.

6.2 *Insulation Resistance*—Perform the insulation resistance test in accordance with Test Method E 780. The electrical resistance between thermoelements and the sheath shall be in accordance with Table 3, with the applied voltage specified (both direct and reversed polarity) before closures on both Class 1 and Class 2 thermocouples for a thermocouple length not exceeding 50 ft (15 m). This section also applies to completed Class 1 thermocouples in the respect that the purchaser may select a sample thermocouple from each lot and remove the measuring junction to perform the test and exercise

due caution to prevent moisture pickup. If the thermocouple fails this test, reject the “lot” of thermocouples. This section also applies to completed Class 2 thermocouples with respect to the insulation resistance between wires and sheath; in this case the purchaser may accept or reject thermocouples individually.

6.3 *Radiographic Inspection:*

6.3.1 Examine a length of the fabricated thermocouple extending a minimum of 4 in. (102 mm) from the measuring junction, including the weld closure, by radiography to determine that the dimensions are in conformance with Table 1 and that any defects do not exceed the requirements in 6.3.1.1 and 6.3.1.2:

6.3.1.1 Cracks, voids, or inclusions in the sheath wall greater than 15 % of the sheath wall thickness, or 0.002 in. (0.05 mm), whichever is greater,

6.3.1.2 Cracks, voids, inclusions, discontinuities, or local reduction of the conductors, insulation, or sheath diameter in or near the thermal junction greater than 0.002 in. (0.05 mm).

6.3.2 Radiograph the thermocouple in two directions 90 ° apart and perpendicular to the thermocouple axis.

6.3.3 Perform the radiography in accordance with Guide E 94, at a sensitivity level at 2-1T.

6.3.4 The use of nonfilm techniques is permitted.

6.3.5 Supply the radiograph to the purchaser with appropriate means to identify the thermocouple with its radiograph.

6.4 *Sheath Integrity:*

6.4.1 Inspect in accordance with Test Methods E 839, Sheath Integrity-Mass Spectrometer Method.

6.5 *Surface Finish*—The surface of the sheaths of all thermocouples in the completed condition shall have a bright appearance with a finish no rougher than 32 rms μ m. Make a visual comparison with roughness standards in accordance with ANSI B46.1.

6.6 *Surface Defects*—There shall be no cracks, seams, holes, or other defects on the surface of the sheath of the finished thermocouples when tested in accordance with Procedure A2 or B3 of Test Method E 165. Any indication of cracks, seams, holes, or other defects shall be cause for rejection.

6.7 *Metallurgical Structure of the Sheath:*

6.7.1 Conduct tests on the austenitic stainless-steel sheath on a section of the sample thermocouple selected in accordance with 6.1. Close wind the selected section of the sheath three full turns on a mandrel twice the sheath diameter. Cut the center turn from the section and mount for metallographic examination. Prepare the metallographic specimen in accordance with Practice E 3. The sheath material at the mounted specimen shall not contain evidence of cracks or localized wall thinning when longitudinally sectioned and examined by

TABLE 3 Insulation Resistance

Sheath Outside Diameter, in. (mm)	Applied D-C Voltage (Both Direct and Reversed Polarity)	Required Minimum Insulation Resistance at Room Temperature, M Ω
0.040 to 0.058 (1.0 to 1.48)	50	1000
0.059 to 0.250 (1.49 to 6.35)	500	5000

normal metallographic practice at a magnification of 200 to 500 × in accordance with Guide E 883.

6.7.2 Mount a transverse section from the sample thermocouple, which has not been bent, and examine for grain size, defects, and grain boundary attack. Grain size shall not exceed the maximum specified in Table 2 as determined by the Comparison Procedure of Test Methods E 112. Defects or grain boundary attack shall not penetrate the wall in excess of 10 % of the wall thickness or 0.002 in. (0.05 mm), whichever is smaller.

6.7.3 Mount a longitudinal section from the sample thermocouple, which has not been bent, and determine the inclusion level by Method A of Test Methods E 45. The inclusion level shall be less than 3 A through D, thin or heavy. Defects or grain boundary attack shall not penetrate the wall in excess of 10 % of the wall thickness or 0.002 in. (0.05 mm), whichever is smaller.

NOTE 2—If specified by the purchaser of the thermocouples, the embrittlement test specified in Practices A 262 can be performed on the sample thermocouple as a check for intergranular attack or excessive carbide precipitation. Acceptance levels shall be agreed upon between the purchaser and the producer.

6.8 *Thermal Cycling of Measuring Junction*—Test the individual conductive wires of each finished thermocouple for electrical continuity, at a voltage not to exceed 6 V ac (rms) or 6 V dc, after five consecutive thermal cycles as follows:

6.8.1 The testing medium shall be noncorrosive, and shall be maintained at a temperature of 775 ± 25 °F (413 ± 14 °C) during the test.

6.8.2 Cycle by immersing the measuring junction end of the thermocouple in the testing medium at a minimum depth of 3 in. (76.2 mm) and hold for 2 to 5 min. Remove from the testing medium and cool by means of a room temperature water quench within 5 s. The total elapsed time at room temperature shall be no less than 1 min before recycling.

6.9 *Insulation Resistance After Thermal Cycling*—The Class 2 thermocouple shall be retested and shall meet the requirements of 6.2.

6.10 *Calibration:*

6.10.1 *Calibration After Conducting Thermal Cycling Tests*—Calibrate the finished thermocouple at the following temperatures: 212 °F (100 °C), 450 °F (232 °C), and 787 °F (419 °C); all test temperatures must be realized within ±25 °F (±14 °C). The tolerance on initial values of emf versus temperature shall be in accordance with Specification E 230.

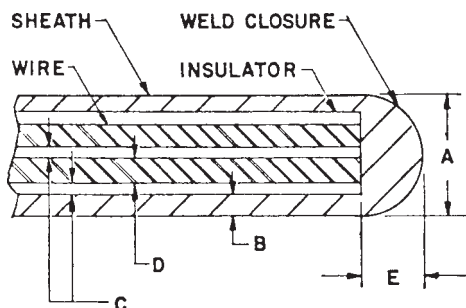

FIG. 1 Grounded Measuring Junction, Class 1

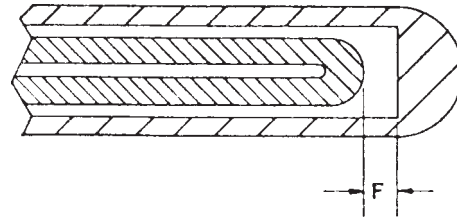

FIG. 2 Insulated (Ungrounded) Measuring Junction, Class 2

Perform the calibration in accordance with the general procedures outlined in Test Method E 220.

6.10.2 *Calibration of the Sample Thermocouple at Higher Temperatures*—Calibrate the section of the sample thermocouple (selected in accordance with 6.1) that has a measuring junction, at the following temperatures: 1000 °F (538 °C), 1350 °F (732 °C), and 1650 °F (899 °C); all test temperatures must be realized within ±25 °F (±14 °C). The tolerance on initial values of emf versus temperature shall be in accordance with Specification E 230. Perform the calibration in accordance with 6.10.1.

6.11 *Minimum Insulation Density*—The minimum density of the compacted electrical insulation shall be 70 % of the maximum theoretical density, which is 0.129 lb/in.³ (3580 mg/cm³) for MgO and 0.143 lb/in.³ (3970 mg/cm³) for Al₂O₃ (alpha alumina).

NOTE 3—These values are taken from the *Handbook of Chemistry and Physics*, Chemical Rubber Publishing Co.

NOTE 4—The test method for determining compaction density are specified in Test Methods E 839 and should be used unless otherwise agreed upon between the purchaser and the producer.

7. Certification and Test Reports

7.1 Submit copies of the following certification test and inspection reports to the purchaser:

- 7.1.1 Certification that the thermoelements used in the manufacture of the thermocouples are in accordance with the purchaser’s ordering documents and the requirements of Specification E 230, for the designated material described in 5.1.2,
- 7.1.2 Chemical analysis of the sheath material, and
- 7.1.3 Certified results of insulation composition tests (see 5.1.3).

7.2 Submit copies of the following general test:

- 7.2.1 Test results on insulation resistance tests (see 6.2),
- 7.2.2 Radiograph results of radiographic inspection (see 6.3),
- 7.2.3 Test results of sheath integrity tests (see 6.4),
- 7.2.4 Results of liquid penetrant inspection (see 6.6), and
- 7.2.5 Test results from thermal cycle tests (see 6.8).

7.3 Submit copies of the following sample tests.

- 7.3.1 Test results on metallurgical structure (see 6.7) and
- 7.3.2 Calibration results (see 6.10.1 and 6.10.2)

8. Packaging, Marking, Shipping, and Preservation

8.1 *Sealing*—Seal-weld all open ends of each thermocouple prior to shipment. To distinguish the sealed end from the thermal-junction end of each thermocouple, the sealed end shall have a weld bead at least twice the sheath diameter.

8.2 *Thermocouple Identification*—Individually identify each thermocouple by two corrosion-resisting metal tags, each

approximately 0.75 in. (19 mm) by 2 in. (51 mm) affixed to the thermocouple, with paper or plastic-coated corrosion-resistant wire. Locate the tags approximately 6 in. (152 mm) from each end. The tags shall bear the thermocouple manufacturer's name and serialized identification number for easy cross-reference to all records on sheath, insulation, conductor wires, and radiographs for each thermocouple. Also indicate the buyer's purchase order.

8.3 Packaging and Shipping—Clean the thermocouple outer sheaths free of grease, oil, fingermarks, dirt, scale, and other foreign matter before packaging. Ship thermocouples in straight lengths if under 10 ft (3.0 m) in length or if greater than 0.1250 in. (3.175 mm) in diameter, or in coils of a diameter not less than 200 times sheath diameter or 18 in. (460 mm) in coil

diameter, whichever is greater. Protect the thermocouples in a dust-tight container. It shall be the responsibility of the manufacturer to construct the container in a manner to prevent thermocouples from being damaged during shipment and handling.

8.4 Marking—Plainly mark each shipping container with the address of the purchaser, purchase order number, and the name of the manufacturer.

9. Keywords

9.1 grounded junction; high-reliability thermocouple; insulated junction; metal-sheathed; mineral insulated; thermocouple

ASTM International takes no position respecting the validity of any patent rights asserted in connection with any item mentioned in this standard. Users of this standard are expressly advised that determination of the validity of any such patent rights, and the risk of infringement of such rights, are entirely their own responsibility.

This standard is subject to revision at any time by the responsible technical committee and must be reviewed every five years and if not revised, either reapproved or withdrawn. Your comments are invited either for revision of this standard or for additional standards and should be addressed to ASTM International Headquarters. Your comments will receive careful consideration at a meeting of the responsible technical committee, which you may attend. If you feel that your comments have not received a fair hearing you should make your views known to the ASTM Committee on Standards, at the address shown below.

This standard is copyrighted by ASTM International, 100 Barr Harbor Drive, PO Box C700, West Conshohocken, PA 19428-2959, United States. Individual reprints (single or multiple copies) of this standard may be obtained by contacting ASTM at the above address or at 610-832-9585 (phone), 610-832-9555 (fax), or service@astm.org (e-mail); or through the ASTM website (www.astm.org).