



Standard Test Method for Thermal Conductivity of Refractories by Hot Wire (Platinum Resistance Thermometer Technique)¹

This standard is issued under the fixed designation C 1113; the number immediately following the designation indicates the year of original adoption or, in the case of revision, the year of last revision. A number in parentheses indicates the year of last reapproval. A superscript epsilon (ϵ) indicates an editorial change since the last revision or reapproval.

1. Scope

1.1 This test method covers the determination of thermal conductivity of non-carbonaceous, dielectric refractories.

1.2 Applicable refractories include refractory brick, refractory castables, plastic refractories, ramming mixes, powdered materials, granular materials, and refractory fibers.

1.3 Thermal conductivity k-values can be determined from room temperature to 1500°C (2732°F), or the maximum service limit of the refractory, or to the temperature at which the refractory is no longer dielectric.

1.4 This test method is applicable to refractories with k-values less than 15 W/m·K (100 Btu·in./h·ft²·°F).

1.5 In general it is difficult to make accurate measurements of anisotropic materials, particularly those containing fibers, and the use of this test method for such materials should be agreed between the parties concerned.

1.6 The values stated in SI units are to be regarded as standard.

1.7 *This standard does not purport to address the safety concerns, if any, associated with its use. It is the responsibility of the user of this standard to establish appropriate safety and health practices and determine the applicability of regulatory limitations prior to use.*

2. Referenced Documents

2.1 ASTM Standards:

C 134 Test Methods for Size and Bulk Density of Refractory Brick and Insulating Firebrick²

C 201 Test Methods for Thermal Conductivity of Refractories²

C 865 Practice for Firing Refractory Concrete Specimens²

E 691 Practice for Conducting an Interlaboratory Test Program to Determine the Precision of Test Methods³

2.2 ISO Standard:

DIS*8894-2 Refractory Materials - Determination of Thermal Conductivity up to 1250°C of Dense and Insulating

Refractory Products According to the Hot Wire Parallel Method⁴

3. Terminology

3.1 Symbols:

3.1.1 R_T —hot wire resistance at any temperature, ohms.

3.1.2 R_0 —hot wire resistance at 0°C (32°F) (from an ice bath), ohms.

3.1.3 L —hot wire length, cm.

3.1.4 T —sample test temperature, °C.

3.1.5 V —average voltage drop across hot wire, volts.

3.1.6 V_s —average voltage drop across standard resistor, volts.

3.1.7 R_s —average resistance of standard resistor, ohms.

3.1.8 I —average current through hot wire (V_s/R_s), amperes.

3.1.9 Q —average power input to hot wire (I^2V^*100/L) during test, watts/m.

3.1.10 t —time, min.

3.1.11 B —slope of linear region in R_T vs. $\ln(t)$ plot.

3.1.12 k —thermal conductivity, W/m·K.

3.1.13 a , b , c —coefficients of a second degree polynomial equation relating hot wire resistance and temperature.

3.1.14 V , I , and Q are preferably measured in the linear region of the R_T versus $\ln(t)$ plot for maximum data accuracy.

4. Summary of Test Method

4.1 A constant electrical current is applied to a pure platinum wire placed between two brick. The rate at which the wire heats is dependent upon how rapidly heat flows from the wire into the constant temperature mass of the refractory brick. The rate of temperature increase of the platinum wire is accurately determined by measuring its increase in resistance in the same way a platinum resistance thermometer is used. A Fourier equation is used to calculate the k-value based on the rate of temperature increase of the wire and power input.⁵

5. Significance and Use

5.1 The k-values determined at one or more temperatures can be used for ranking products in relative order of their thermal conductivities.

¹ This test method is under the jurisdiction of ASTM Committee C-8 on Refractories and is the direct responsibility of Subcommittee C08.02 on Thermal and Thermochemical Properties.

Current edition approved March 10, 1999. Published July 1999. Originally published as C 1113-90. Last previous edition C 1113-90 (1997)^{E1}.

² Annual Book of ASTM Standards, Vol 15.01.

³ Annual Book of ASTM Standards, Vol 14.02.

⁴ Available from American National Standards Institute, 11 W. 42nd St., 13th Floor, New York, NY 10036.

⁵ Morrow, G.D., "Improved Hot Wire Thermal Conductivity Technique", *Bull. Amer. Ceram. Soc.*, 58(7), 1979, pp. 687-90.

5.2 Estimates of heat flow, interface temperatures, and cold face temperatures of single, and multi-component linings can be calculated using k-values obtained over a wide temperature range.

5.3 The k-values determined are “at temperature” measurements rather than “mean temperature” measurements. Thus, a wide range of temperatures can be measured, and the results are not averaged over the large thermal gradient inherent in water-cooled calorimeters.

5.4 The k-values measured are the combination of the k-values for the width and thickness of the sample, as the heat flow from the hot wire is in both of those directions. The water-cooled calorimeter measures k-value in one direction, through the sample thickness.

5.5 The test method used should be specified when reporting k-values, as the results obtained may vary with the type of test method that is used. Data obtained by the hot wire method are typically 10 to 30 % higher than data obtained by the water calorimeter method given in Test Method C 201.

6. Apparatus

6.1 A block diagram of a suggested test apparatus is shown in Fig. 1. Details of the equipment are as follows:

6.1.1 *Furnace*, with a heating chamber capable of supporting two 228-mm (9-in.) straight brick. The furnace temperature may be controlled with a set point controller adjusted manually between test temperatures, with a programmable controller, or with the computer. If a programmable controller is used, and the hot wire power is applied by computer, the furnace temperature program must be synchronized with the computer program used to collect the test data. The furnace temperature should be accurate to $\pm 5^\circ\text{C}$ (9°F) and controlled to within a $\pm 1^\circ\text{C}$ (1.8°F) precision such that the temperature variation with time is minimized. Temperature stability measurements are not required by this test method because small temperature variations with time are difficult to measure and dependent on thermocouple placement (in air, a protection tube, or in the sample). However, if sample temperature measurements are averaged during a 30 minute period after furnace equilibration (prior to a hot wire test), the maximum-minimum difference should preferably be less than 1°C (1.8°F). In addition, if a linear regression analysis is done on the average temperature

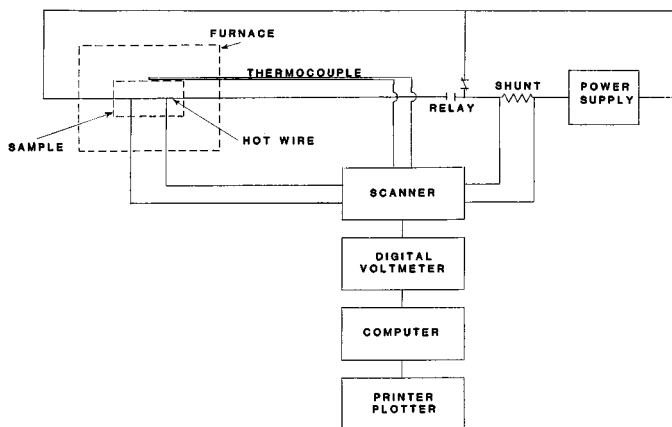

FIG. 1 Diagram of Apparatus

vs. time data, the rate of temperature change should preferably be less than 0.05°C (0.09°F)/min. Four holes with alumina protection tubes shall be provided in the kiln wall for the platinum voltage and current leads. These holes should be widely spaced to minimize electrical conductivity at elevated temperatures.

6.1.2 *Thermocouple*, to measure sample temperature.

6.1.3 *Programmable Power Supply*, capable of constant current control in the range from 0 to 10 A (0 to 50 V). During a 10-min test period, stability should be ± 0.002 A. Size the power supply according to the anticipated wire harnesses diameter and type of materials to be tested. A high (5–10 A) ampere supply is suggested for large diameter wire and/or testing of high conductivity materials. However, lower ampere supplies will give better current control for low currents used for low conductivity materials or with a smaller diameter wire harness.

6.1.4 *Shunt*, with a resistance of 0.1Ω rated at 15 A.

6.1.5 *Programmable Scanner*, capable of directing several different voltage inputs to the digital voltmeter. It is also used to activate a relay to turn on and off the test circuit.

6.1.6 *Relay*, with a current rating of 25 A at 24 V.

6.1.7 *Programmable Digital Voltmeter*, with auto ranging, auto calibration, and $6 \frac{1}{2}$ digit resolution.

6.1.8 *Computer*, capable of controlling the operation of the power supply, scanner, and digital voltmeter. It must also be able to collect and analyze the test results. Commercially available data acquisition (with an IEEE device and sequential file numbering capability) and analysis (spreadsheet with macro capability) software is acceptable; custom software is not necessary.

6.1.9 *Printer/Plotter*, capable of documenting the raw data and various calculated values. The plotter function is used to plot the resistance versus \ln (time) relationship. This is used to visually determine if a linear relationship was obtained and the location of the linear region.

6.2 *Reusable Test Harness*, consisting of a straight section at least 30-cm (11.8-in.) long with two perpendicular voltage leads about 15-cm (5.9-in.) apart near the center per Fig. 2. To avoid thermocouple effect voltage errors, use pure platinum wire for the test harness, and for the entire length of voltage leads. Platinum alloy wire may be used only for current leads from outside the furnace to the test harness section itself. The platinum voltage lead wires may be taken to an insulated terminal box on the side of the furnace for connection to lower temperature lead wires, or run all the way back to the digital voltmeter terminals. The main part of the harness wire shall be between 0.330 and 0.508-mm (0.013 and 0.020-in.) diameter. The voltage leads may be the same size as the main harness wire, although it is recommended that they be 0.330-mm (0.013-in.) or smaller such that their area is less than half that of the main wire. The current leads up to the main harness shall be at least the same size as the main harness wire. The main harness may be fabricated by butt welding voltage leads to a solid main wire using a micro torch or arc percussion welder, or by arc welding the wires into a bead. If beads are made by arc welding, keep the bead size as small as possible, and carefully straighten out the bead to form a tee joint with the

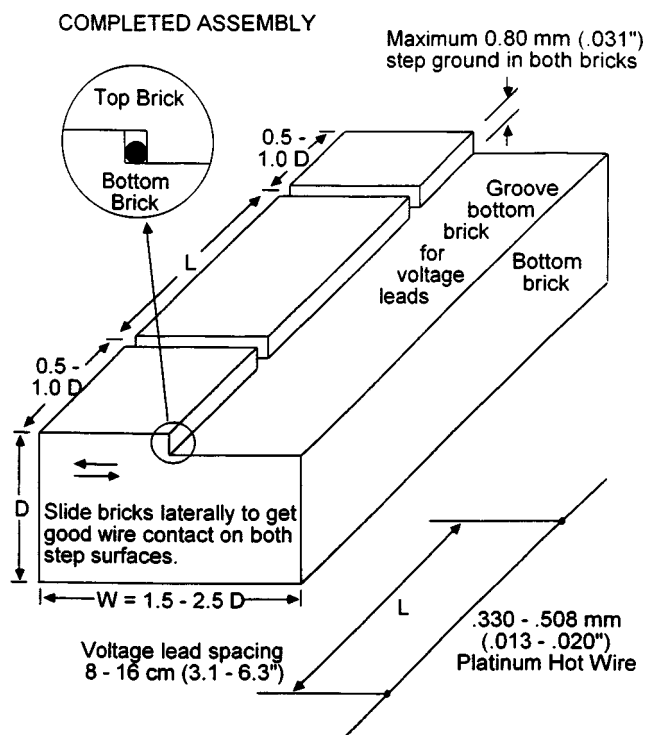

FIG. 2 Hot Wire Sample Setup

and voltage leads, it is permissible to chip out small cavities in the brick at these locations using a hammer and center punch.

7.2.2 Refractory Castables—Refractory castables specimens can be cut into brick shapes and prepared as in 7.2.1 or a special castable mold with the 0.8-mm (0.032 in.) step can be used to form the brick shapes. Two thin grooves must be cut for the perpendicular voltage leads in one of the brick. The hot wire harness can also be cast in place for a single usage.

7.2.3 Plastic Refractories and Ramming Mixes—Immediately after forming, press the hot wire harness between two 228-mm (9-in.) straight bricks. Pressure should be applied during drying to keep the brick in very close contact.

7.2.4 Low-Strength Materials—Use a sharp knife to scribe grooves into one of the brick into which the hot wire harness will be pressed.

7.2.5 Compressible Refractory Fiber Blankets—Fabricate a weighted cover to compress and hold the samples to the desired thickness (and bulk density) during testing. A cover and side spacers are required.

7.2.6 Powdered or Granular Materials—A refractory container must be fabricated to contain powdered or granular materials. The container may be of two parts each the size of a 228-mm (9-in.) straight brick. The lower part will have four sides and a bottom. The upper part will have four sides only. Alternatively, a container of one part only may be used. The one-part container will have the volume of two 228-mm (9-in.) brick. Record the weight and interior volume for use in calculating the apparent bulk density of the test material.

voltage lead perpendicular to the main wire.

7. Sampling and Specimen Preparation

7.1 The test specimens consist of two 228-mm (9-in.) straight brick or equivalent. Select these specimens for uniformity of structure and bulk density. Bulk density should be determined in accordance with Test Method C 134.

7.2 The hot wire harness is positioned near the center of the two brick shaped specimens and in intimate contact with both either by using samples with a step diamond ground into the mating surface, by forming the sample around the harness, or by deformation of soft samples. See Fig. 2 for a schematic of how the steps provide intimate lateral contact with both halves of the sample assembly.

7.2.1 Refractory Brick—The steps cut in the brick shall have a maximum depth of 0.8-mm (0.032-in.), although lesser depths can be used for wires smaller than the 0.508-mm (0.020-in.) maximum wire size. To insure that samples do not rock, the average depth of both steps shall be within 0.1-mm (0.004-in.) of each other. In addition, the mating surfaces shall be flat to less than 0.1-mm (0.004-in.) as determined by the following procedure. After the steps are ground, the bricks shall be placed together with the steps touching each other to check for any noticeable rock or movement between the two bricks; no visible movement is acceptable. Rock is most often caused by the use of a grinding wheel which has a high spot in the center, causing a smaller step depth close to the step than across the rest of the mating surface. Dressing the wheel so that it is flat or that the side which forms the step edge is high will normally provide acceptable results. After the step height and mating surfaces are acceptable, voltage lead grooves shall be cut across the high part of the step in one of the samples. To accommodate the weld beads at the junctions of the main wire

8. Calibration

8.1 Depending on the data analysis calculation method used, it may be necessary to determine the resistance of each test harness at 0°C (32°F) (R_o). This can be done experimentally by placing the harness in a plastic tray with a slurry of crushed ice, and measuring the resistance using the same 4-wire method which is used for elevated temperature resistance measurements. An alternate method is to measure the resistance of the harness at room temperature and calculate an R_o value from $R_T/R_o = (a + b * T + c * T^2)$ where the equation coefficients are obtained from prior tests of the wire lot. Wire harness calibration at 0°C (32°F) is not required if the wire resistance vs. temperature measurement method is used.

9. Setup Procedure

9.1 Measure the hot wire length, L, to the nearest 0.025-cm (0.01-in.). This distance is measured between the voltage leads.

9.2 Refractory Brick—Position the hot wire harness on the grooved brick. Place the other brick on top and slide them together to lock the wire into very close contact with both bricks.

9.3 Low-Strength Materials—Press the hot wire harness into the scribed grooves.

9.4 Compressible Refractory Fiber Blankets—Position the hot wire harness between the fiber samples. Several layers may be necessary for thin samples.

9.5 Powdered or Granular Materials—If a two-part container is used, fill the lower part with sample material level to its top. Position the hot wire harness in the top center of the lower part. Place the upper container part in position and fill it

with additional test material. If a one-part container is used, fill it approximately half way with test material, install the hot wire harness through small holes drilled in the container, and complete the filling with test material. For either type sample container, weigh the entire test setup and calculate the apparent bulk density.

9.6 Place the assembled test specimens into the furnace chamber on two supports to ensure uniform heating and weld the voltage and current leads to the corresponding hot wire leads. A micro-torch is well suited for this. Compress soft fiber samples with a weighted cover to the desired thickness (and bulk density). Position the thermocouple at the top center of the test specimens. Pull excess voltage lead wire outside the furnace to minimize wire length inside which may pick up AC noise from heating elements above 1000°C (1832°F).

10. Test Procedure

10.1 Program the computer and any separate furnace controller to obtain the desired test temperatures and soak times. Heating rates below 180°C/h (324°F/h) are recommended for all materials to avoid thermal shock damage to the furnace and samples. Rates as slow as 55°C/hr (100°F/h) are preferred for castable test specimens (see Practice C 865). Once the desired test temperature is reached, soak for minimum of 4 h before beginning test measurements if the furnace is separately controlled. Soak periods of 8 h may be required at lower temperatures, especially for low conductivity materials. If the furnace is controlled by a computer which is programmed to check for thermal stability, the minimum soak period is not required. At least four test temperatures (for example, room and three additional points) shall be used to generate data for curve fitting. For monolithic (unfired) materials, test the samples only during the initial heating cycle to obtain heating curve data; other materials may be tested using either heating or cooling test points.

10.2 Measure the hot wire resistance at each test temperature to the nearest 1.0×10^{-6} ohms using a low power input. This is best done by setting the test unit power supply for a 0.1–0.2 A output and using the voltage drop across the standard resistor to accurately measure the current. The same method of measuring resistance should be used at all temperatures.

10.3 Power the wire with a test current to obtain a maximum temperature rise (dT/dt) of 0.5°C/min (0.9°F/min). Power levels may be calculated by the computer or preselected for each material and test temperature combination. Table 1 is provided as a guide for preselecting test currents. A maximum current of 8 amperes at room temperature corresponds to a maximum power input of about 6 watts, or about 0.5 watts/cm (1.3 watts/in.) of wire. Close the test circuit, apply the current for a period of 5 (high conductivity materials) to 10 (low conductivity materials) min, and record the resistance versus time data with the computer at time intervals of 3 s or less. At the end of the test period, open the test circuit and discontinue data acquisition while the sample temperature re-equilibrates.

10.4 Wait a minimum of 1 h for the sample temperature to equilibrate, and then repeat the power test at least three times at each test temperature. The same test current need not be used for each test repetition, depending on the software utilized. At room temperature, there is a tendency for the furnace tempera-

TABLE 1 Maximum Currents in Amps for 0.508 mm (0.020 in.) Wire^A

Density kg/m ³ (lb/ft ³)	Typical Material	Temperature °C (°F)			
		25 (77)	400 (753)	800 (1472)	1200 (2192)
120 (7.49)	Fiber Blanket	0.4	0.6	0.8	1
300 (18.7)	Fiber Board	1	0.8	0.8	0.8
370 (23.1)	Block Insulation	1	0.8	0.8	0.8
480 (30.0)	2000 Insulating Brick	1.2	0.8	0.6	0.6
640 (39.9)	2300 Insulating Brick	1.4	1	0.8	0.6
800 (49.9)	2600 Insulating Brick	1.6	1.2	1	1
960 (59.9)	2800 Insulating Brick	1.6	1.4	1.2	1
1000 (62.4)	Al ₂ O ₃ Powders	1.4	1	0.8	0.8
1200 (74.9)	Insulating Castables	2	1.4	1.2	1.2
1300 (81.1)	Bubble Al ₂ O ₃ Brick	3.6	2	1.6	1.4
1500 (93.6)	Foundry Sand (loose)	1.6	1.2	1.2	1.2
1500 (93.6)	Foundry Sand (bonded)	2.8	1.6	1.4	1.2
1700 (106.1)	Fused SiO ₂	3.2	2	1.8	1.6
2100 (131.0)	Firebrick	3.6	2.4	1.8	1.6
2400 (149.8)	Firebrick	4	2.4	2	1.8
2500 (156.0)	SiC Monolithics	6	4	3.2	reacts ^B
2600 (162.2)	SiC Brick	8 ^C	6	5	reacts ^B
2700 (168.5)	60 % Al ₂ O ₃ LC Castables	5	2.8	2.4	2
2900 (181.0)	Bonded AZS or 80 % Al ₂ O ₃	5	3.2	2.4	2
>3000 (187.2)	>95 % Al ₂ O ₃	8	4	3.2	2.8
>3000 (187.2)	>95 % MgO	8 ^C	5	4	3.6
>3200 (199.7)	Cr ₂ O ₃ /MgO Brick	6	5	3.2	2.8
>3200 (199.7)	Fused AZS	5	3.2	2.8	2.4
>3200 (205.9)	Zirconia Brick	3.2	2	1.8	1.6

^AFor 0.406-mm (0.160-in.) wire, multiply above settings by 0.80 to obtain about the same temperature rise; for 0.330-mm (0.130-in.) wire, multiply the above settings by 0.65.

^BPlatinum wire will react with SiC at high temperature. Testing of SiC products above 540°C (1000°F) may cause damage.

^CHigh conductivity materials give low R versus $\ln(t)$ slopes and may not give repeatable results if the k value exceeds 15 W/m-K (104 Btu-in./h-ft²°F).

ture to rise gradually even though the furnace power is off, so wait periods longer than 1 h are desirable at this temperature.

10.5 Calculate the final test results after all elevated temperature testing is completed so that R_T data from the entire temperature range can be curve fit.

11. Calculation

11.1 *Regression Coefficients*—Use a polynomial regression analysis to curve fit the low power resistance or resistivity (R_T/R_o) versus temperature data to a polynomial equation of the form $a + b*T + c*T^2$ using data from a minimum of 4 test temperatures (for example, room temperature and 3 elevated temperatures).

11.1.1 The classical method is to use R_T/R_o (resistance/resistance at 0°C (32°F)) data, in which case R_o must be measured or calculated. Since R_o will vary with use due to stretching or cold work of the wire, or both, it must be periodically remeasured using a 0°C (32°F) ice bath slurry, or recalculated from a room temperature measurement and previously determined polynomial regression coefficients in accordance with the relation $R_T/R_o = a + b*T + C*T^2$. The advantage of using R_T/R_o data is that the regression coefficients are normalized and directly comparable to data from other sources (for example, different runs of the same wire or data from harnesses of different lengths or wire diameters).

11.1.2 An alternate method is to curve fit only resistance and temperature data. The advantage of this method is that all data are determined with the sample in place, eliminating the need for ice bath measurements of R_o , and eliminating handling effects which cause subtle changes in resistance. Thus,

this method is generally preferred for routine testing. The disadvantage is that the resistance/temperature regression coefficients require each experimental run to be made to elevated temperatures, and that the coefficients will vary with harness length and diameter.

11.2 *Slope Calculation*—Calculate the slope (B) of the R_T versus $\ln(t)$ plot from the linear region of each test using an appropriate linear regression analysis method. The linear region may be determined by computer analysis with software, or by visual examination of the R_T versus $\ln(t)$ plots. To avoid biasing the linear regression analysis toward the upper part of the R_T versus $\ln(t)$ plot, it is recommended that the analysis be done over uniform $\ln(t)$ intervals. This may involve acquiring the data in ever increasing periods of time, or averaging an increasing number of data points collected at a uniform sampling rate, before conducting the regression analysis. If a linear region is not found, either the material is unsuitable, or an operating error may have been made and the test should be repeated.

11.3 *k-Value Calculation*—Calculate thermal conductivity (k) from the slope (B) of the resistance versus $\ln(t)$ data collected during each high power test, and the polynomial equation coefficients from 11.1, using Eq 7 or Eq 8: The Fourier equation for heat flow from a line source is as follows:

$$k = \frac{Qd\ln(t)}{4\pi dT} \quad (1)$$

if:

$$\frac{R_T}{R_o} = a + bT + cT^2, \text{ then } \frac{dR_T}{dT} = dR_o(b + 2cT) \quad (2)$$

if:

$$B = \text{slope of } R_T \text{ versus } \ln(t) = \frac{dR_T}{d\ln(t)} = \frac{dTR_o(b + 2cT)}{d\ln(t)} \quad (3)$$

Then:

$$d\ln(t) = \frac{dTR_o(b + 2cT)}{B} \text{ and substituting in } k, \quad (4)$$

$$k = \frac{QR_o(b + 2cT)}{4\pi B} \quad (5)$$

Substituting:

$$Q = \frac{VI100}{L} = \frac{VV_s100}{R_sL} \text{ in } k, \quad (6)$$

$$k = \frac{VV_s100R_o(b + 2cT)}{R_sLA\pi B} \quad (7)$$

where the units are W/m·K in accordance with Section 3. Alternately, if the relation $R_T = a + bT + cT^2$ is used, then:

$$k = \frac{VV_s100(b + 2cT)}{R_sLA\pi B} \quad (8)$$

where: the units are W/m·K in accordance with Section 3. If desired, calculate the k values in Btu·in./h·ft²·°F units by

multiplying the W/m·K values by 6.93577.

11.4 *Rate of Temperature Rise*—For each test, calculate the rate of temperature rise of the wire at a time of 1 min using Eq 13 or Eq 16:

if:

$$\frac{R_T}{R_o} = a + bT + cT^2 \text{ is the equation used,} \quad (9)$$

then:

$$\frac{dR_T}{dT} = R_o(b + 2cT), \text{ and } dR_T = R_o(b + 2cT)dT \quad (10)$$

also:

$$B = \frac{dR_T}{d\ln(t)} = \frac{dR_T}{dT}, \text{ so } dR_T = \frac{Bdt}{t} = R_o(b + 2cT)dT \quad (11)$$

rearranging:

$$\frac{dT}{dt} = \frac{B}{R_o(b + 2cT)t} \quad (12)$$

so for:

$$t = 1 \text{ minute, } \frac{dT}{dt} = \frac{B}{R_o(b + 2cT)} \quad (13)$$

alternately, for:

$$R_T = a + bT + cT^2, \quad (14)$$

so for:

$$\frac{dT}{dt} = \frac{B}{(b + 2cT)t} \quad (15)$$

$$t = 1 \text{ min, } \frac{dT}{dt} = \frac{B}{(b + 2cT)} \quad (16)$$

12. Report

12.1 Report the following information:

12.1.1 Brand name or other identifying information,

12.1.2 In the case of unfired materials, any thermal pretreatment given,

12.1.3 The average bulk density of the dried samples,

12.1.4 The individual temperatures and k-values measured at each temperature,

12.1.5 The average temperature and k-value measured at each temperature, and

12.1.6 A curve of thermal conductivity versus temperature.

13. Precision and Bias

13.1 It has been determined by Subcommittee C08.02 that this revision requires a new determination of precision and bias. This information is being developed. Refer to Test Method C 1113–90 for precision and bias of this test method before revision.

14. Keywords

14.1 hot wire; refractories; thermal conductivity

 **C 1113**

The American Society for Testing and Materials takes no position respecting the validity of any patent rights asserted in connection with any item mentioned in this standard. Users of this standard are expressly advised that determination of the validity of any such patent rights, and the risk of infringement of such rights, are entirely their own responsibility.

This standard is subject to revision at any time by the responsible technical committee and must be reviewed every five years and if not revised, either reapproved or withdrawn. Your comments are invited either for revision of this standard or for additional standards and should be addressed to ASTM Headquarters. Your comments will receive careful consideration at a meeting of the responsible technical committee, which you may attend. If you feel that your comments have not received a fair hearing you should make your views known to the ASTM Committee on Standards, 100 Barr Harbor Drive, West Conshohocken, PA 19428.