



Designation: C 1291 – 00a

Standard Test Method for Elevated Temperature Tensile Creep Strain, Creep Strain Rate, and Creep Time-to-Failure for Advanced Monolithic Ceramics¹

This standard is issued under the fixed designation C 1291; the number immediately following the designation indicates the year of original adoption or, in the case of revision, the year of last revision. A number in parentheses indicates the year of last reapproval. A superscript epsilon (ϵ) indicates an editorial change since the last revision or reapproval.

1. Scope

1.1 This test method covers the determination of tensile creep strain, creep strain rate, and creep time-to-failure for advanced monolithic ceramics at elevated temperatures, typically between 1073 and 2073 K. A variety of specimen geometries are included. The creep strain at a fixed temperature is evaluated from direct measurements of the gage length extension over the time of the test. The minimum creep strain rate, which may be invariant with time, is evaluated as a function of temperature and applied stress. Creep time-to-failure is also included in this test method.

1.2 This test method is for use with advanced ceramics that behave as macroscopically isotropic, homogeneous, continuous materials. While this test method is intended for use on monolithic ceramics, whisker- or particle-reinforced composite ceramics as well as low-volume-fraction discontinuous fiber-reinforced composite ceramics may also meet these macroscopic behavior assumptions. Continuous fiber-reinforced ceramic composites (CFCCs) do not behave as macroscopically isotropic, homogeneous, continuous materials, and application of this test method to these materials is not recommended.

1.3 The values in SI units are to be regarded as the standard (see Practice E 380).

1.4 *This standard does not purport to address all of the safety concerns, if any, associated with its use. It is the responsibility of the user of this standard to establish appropriate safety and health practices and determine the applicability of regulatory limitations prior to use.*

2. Referenced Documents

2.1 *ASTM Standards:*

¹ This test method is under the jurisdiction of ASTM Committee C-28 on Advanced Ceramics and is the direct responsibility of Subcommittee C28.01 on Properties and Performance.

Current edition approved ~~June~~ Oct. 10, 2000. Published ~~October 2000~~ January 2001. Originally published as C 1291 – 95. Last previous edition ~~1291 – 95¹~~ 1291 – 00.

- E 4 Practices for Force Verification of Testing Machines²
- E 6 Terminology Relating to Methods of Mechanical Testing²
- E 83 Practice for Verification and Classification of Extensometers²
- E 139 Practice for Conducting Creep, Creep-Rupture, and Stress-Rupture Tests of Metallic Materials²
- E 177 Practice for Use of the Terms Precision and Bias in ASTM Test Methods³
- E 220 Test Method for Calibration of Thermocouples by Comparison Techniques⁴
- E 230 Temperature-Electromotive Force (EMF) Tables for Standardized Thermocouples⁴
- E 380 Practice for Use of the International System of Units (SI)⁵
- E 639 Test Method for Measuring Total-Radiance Temperature of Heated Surfaces Using a Radiation Pyrometer⁶
- E 691 Practice for Conducting an Interlaboratory Study to Determine the Precision of a Test Method³
- E 1012 Practice for Verification of Specimen Alignment Under Tensile Loading²

3. Terminology

3.1 *Definitions*—The definitions of terms relating to creep testing, which appear in Section E of Terminology E 6 shall apply to the terms used in this test method. For the purpose of this test method only, some of the more general terms are used with the restricted meanings given as follows.

3.2 *Definitions of Terms Specific to This Standard:*

3.2.1 *axial strain, ϵ_a , [nd], n*—the average of the strain measured on diametrically opposed sides and equally distant from the specimen axis.

3.2.2 *bending strain, ϵ_b , [nd], n*—the difference between the strain at the surface and the axial strain.

3.2.2.1 *Discussion*—In general, it varies from point to point around and along the gage length of the specimen.

3.2.3 *creep-rupture test, n*—a test in which progressive specimen deformation and the time-to-failure are measured. In general, deformation is greater than that developed during a creep test.

3.2.4 *creep strain, ϵ_c , n*—the time dependent strain that occurs after the application of load which is thereafter maintained constant. Also known as engineering creep strain.

3.2.5 *creep test, n*—a test that has as its objective the measurement of creep and creep rates occurring at stresses usually well below those that would result in fast fracture.

3.2.5.1 *Discussion*—Since the maximum deformation is only a few percent, a sensitive extensometer is required.

3.2.6 *creep time-to-failure, t_f , [s], n*—the time required for a specimen to fracture under constant load as a result of creep.

3.2.6.1 *Discussion*—This is also known as creep rupture time.

3.2.7 *gage length, l , [m], n*—the original distance between fiducial markers on or attached to the specimen for determining elongation.

3.2.8 *maximum bending strain, ϵ_{bmax} , [nd], n*—the largest value of bending strain along the gage length. It can be calculated from measurements of strain at three circumferential positions at each of two different longitudinal positions.

3.2.9 *minimum creep strain rate, ϵ_{min} , [s^{-1}], n*—minimum value of the strain rate prior to specimen failure as measured from the strain-time curve. The minimum creep strain rate may not necessarily correspond to the steady-state creep strain rate.

3.2.10 *slow crack growth, v , [m/s], n*—subcritical crack growth (extension) which may result from, but is not restricted to, such mechanisms as environmentally assisted stress corrosion, diffusive crack growth, or other mechanisms.

3.2.11 *steady-state creep, ϵ_{ss} , [nd], n*—a stage of creep wherein the creep rate is constant with time.

3.2.11.1 *Discussion*—Also known as secondary creep.

3.2.12 *stress corrosion, n*—environmentally induced degradation that initiates from the exposed surface.

3.2.12.1 *Discussion*—Such environmental effects commonly include the action of moisture, as well as other corrosive species, often with a strong temperature dependence.

3.2.13 *tensile creep strain, ϵ_p , [nd], n*—creep strain that occurs as a result of a uniaxial tensile-applied stress.

4. Significance and Use

4.1 Creep tests measure the time-dependent deformation under load at a given temperature, and, by implication, the load-carrying capability of the material for limited deformations. Creep-rupture tests, properly interpreted, provide a measure of the load-carrying capability of the material as a function of time and temperature. The two tests compliment each other in defining the load-carrying capability of a material for a given period of time. In selecting materials and designing parts for service at elevated temperatures, the type of test data used will depend on the criteria for load-carrying capability that best defines the service usefulness of the material.

4.2 This test method may be used for material development, quality assurance, characterization, and design data generation.

² Annual Book of ASTM Standards, Vol 03.01.

³ Annual Book of ASTM Standards, Vol 14.02.

⁴ Annual Book of ASTM Standards, Vol 14.03.

⁵ Discontinued 1997; Replaced by IEEE/ASTM SI-10.

⁶ Annual Book of ASTM Standards, Vol 15.03.

4.3 High-strength, monolithic ceramic materials, generally characterized by small grain sizes (<50 μm) and bulk densities near their theoretical density, are candidates for load-bearing structural applications at elevated temperatures. These applications involve components such as turbine blades which are subjected to stress gradients and multiaxial stresses.

4.4 Data obtained for design and predictive purposes should be obtained using any appropriate combination of test methods that provide the most relevant information for the applications being considered. It is noted here that ceramic materials tend to creep more rapidly in tension than in compression (**1, 2, 3**).⁷ This difference results in time-dependent changes in the stress distribution and the position of the neutral axis when tests are conducted in flexure. As a consequence, deconvolution of flexural creep data to obtain the constitutive equations needed for design cannot be achieved without some degree of uncertainty concerning the form of the creep equations, and the magnitude of the creep rate in tension vis-a-vis the creep rate in compression. Therefore, creep data for design and life prediction should be obtained in both tension and compression, as well as the expected service stress state.

5. Interferences

5.1 *Time-Dependent Phenomena*—Other time-dependent phenomena, such as stress corrosion and slow crack growth, can interfere with determination of the creep behavior.

5.2 *Chemical Interactions with the Testing Environment*—The test environment (vacuum, inert gas, ambient air, etc.) including moisture content (for example, % relative humidity (RH)) may have a strong influence on both creep strain rate and creep rupture life. In particular, materials susceptible to slow crack growth failure will be strongly influenced by the test environment. Surface oxidation may be either active or passive and thus will have a direct effect on creep behavior by changing the material's properties. Testing must be conducted in environments that are either representative of service conditions or inert to the materials being tested depending on the performance being evaluated. A controlled gas environment with suitable effluent controls must be provided for any material that evolves toxic vapors.

5.3 *Specimen Surfaces*—Surface preparation of test specimens can introduce machining flaws that may affect the test results. Machining damage imposed during specimen preparation will most likely result in premature failure of the specimen but may also introduce flaws that can grow by slow crack growth. Surface preparation can also lead to residual stresses which can be released during the test. Universal or standardized methods of surface preparation do not exist. It should be understood that final machining steps may or may not negate machining damage introduced during earlier phases of machining which tend to be rougher.

5.4 *Specimen/Extensometer Chemical Incompatibility*—The strain measurement techniques described herein generally rely on physical contact between extensometer components (contacting probes or optical method flags) and the specimen so as to measure changes in the gage section as a function of time. Flag attachment methods and extensometer contact materials must be chosen with care to ensure that no adverse chemical reactions occur during testing. Normally, this is not a problem if specimen/probe materials that are mutually chemically inert are employed (for example, SiC probes on Si_3N_4 specimens). The user must be aware that impurities or second phases in the flags or specimens may be mutually chemically reactive and could influence the results.

5.5 *Specimen Bending*—Bending in uniaxial tensile tests can cause extraneous strains or promote accelerated rupture times. Since maximum or minimum stresses will occur at the surface where strain measurements are made, bending may introduce either an over or under measurement of axial strain, if the measurement is made only on one side of the tensile specimen. Similarly, bending stresses may accentuate surface oxidation and may also accentuate the severity of surface flaws.

5.6 *Temperature Variations*—Creep strain is often related to temperature through an exponential function. Thus fluctuations in test temperature or change in temperature profile along the length of the specimen in real time can cause fluctuations in strain measurements or changes in creep rate.

6. Apparatus

6.1 Load Testing Machine:

6.1.1 Specimens may be loaded in any suitable testing machine provided that uniform, direct loading can be maintained. The testing machine must maintain the desired constant load on the specimen regardless of specimen deformation with time, either through dead-weight loading or through active load control. The force measuring system can be equipped with a means for retaining readout of the force, or the force can be recorded manually. The accuracy of the testing machine must be in accordance with Practice E 4.

6.1.2 *Allowable Bending*—Allowable bending, as defined in Practice E 1012, should not exceed 5 %. This is based on the same assumptions as those for tensile strength testing (see Ref 4, for example). It should be noted that unless percent bending is monitored until the end-of-test condition has been reached, there will be no record of percent bending for each specimen. The testing system alignment including the test machine, gripping devices (as described in 6.2), and load train couplers (as described in 6.3), must be verified using the procedure detailed in the appendix such that the percent bending does not exceed 5 at a mean stress equal to one half the anticipated test stress. This verification must be conducted at a minimum at the beginning and the end of each test series. An additional verification of alignment is recommended, although not required, at the middle of the test series. Either a dummy or actual test specimen may be used. Tensile specimens used for alignment verification should be equipped with a recommended eight separate longitudinal strain gages to determine bending contributions from both eccentric and angular

⁷ The boldface numbers in parentheses refer to the list of references at the end of this test method.

misalignment of the grip heads. (Although it is possible to use a minimum of six separate longitudinal strain gages for specimens with circular cross sections, eight strain gages are recommended here for simplicity and consistency in describing the technique for both circular and rectangular cross sections.) If dummy specimens are used for alignment verification, they should have the same geometry and dimensions as the actual test specimens as well as an elastic modulus that closely matches that of the test material to ensure similar axial and bending stiffness characteristics.

6.2 *Gripping Devices:*

6.2.1 Various types of gripping devices may be used to transmit the measured load applied by the testing machine to the test specimens. The brittle nature of advanced ceramics requires a uniform interface between the grip components and the gripped section of the specimen. Line or point contacts and nonuniform pressure can produce Hertzian-type stresses leading to crack initiation and fracture of the specimen in the gripped section. Gripping devices can be classed generally as those employing active and those employing passive grip interfaces as discussed in the following sections. Regardless of the type of gripping device chosen, it must be consistent with the thermal requirements imposed on it by the elevated temperature nature of creep testing. This requirement may preclude the use of some material combinations and gripping designs.

6.2.1.1 *Active Grip Interfaces*—Active grip interfaces require a continuous application of a mechanical, hydraulic, or pneumatic force to transmit the load applied by the test machine to the test specimen. Generally, these types of grip interfaces cause a load to be applied normal to the surface of the gripped section of the specimen. Transmission of the uniaxial load applied by the test machine is then accomplished by friction between the specimen and the grip faces. Thus, important aspects of active grip interfaces are uniform contact between the gripped section of the specimen and the grip faces, and constant coefficient of friction over the grip/specimen interface.

(1) For cylindrical specimens, a one-piece split collet arrangement acts as the grip interface (4, 5). Generally, close tolerances are required for concentricity of both the grip and specimen diameters. In addition, the diameter of the gripped section of the specimen and the unclamped, open diameter of the grip faces must be within similarly close tolerances to promote uniform contact at the specimen/grip interface. Tolerances will vary depending on the exact configuration used.

(2) For flat specimens, flat-face, wedge-grip faces act as the grip interface. Generally, close tolerances are required for the flatness and parallelism as well as wedge angle of the grip faces. In addition, the thickness, flatness, and parallelism of the gripped section of the specimen must be within similarly close tolerances to promote uniform contact at the specimen/grip interface. Tolerances will vary depending on the exact configuration used.

6.2.1.2 *Passive Grip Interfaces*—Passive grip interfaces transmit the load applied by the test machine to the test specimen through a direct mechanical link. Generally, these mechanical links transmit the test loads to the specimen by means of geometrical features of the specimens such as button-head fillets, shank shoulders, or holes in the gripped head. Thus, the important aspect of passive grip interfaces is uniform contact between the gripped section of the specimen and the grip faces.

(1) For cylindrical specimens, a multi-piece split collet arrangement acts as the grip interface at button-head fillets of the specimen (6). Because of the limited contact area at the specimen/grip interface, soft, deformable metallic collets may be used to transfer the axial load to the exact geometry of the specimen. In some cases, tapered collets may be used to transfer the axial load to the shank of the specimen rather than into the button-head radius (6). Generally, moderate tolerances on the collet height must be maintained to promote uniform axial-loading at the specimen/grip interface. Tolerances will vary depending on the exact configuration used.

(2) For flat specimens, pins or pivots act as grip interfaces at either the shoulders of the specimen shank (7, 8) or at holes in the gripped specimen head (9, 10). Generally, close tolerances of shoulder radii and grip interfaces are required to promote uniform contact along the entire specimen/grip interface as well as to provide for non-eccentric loading. Generally, very close tolerances are required for longitudinal coincidence of the pin and the hole centerlines.

6.3 *Load Couplers:*

6.3.1 Various types of devices (load train couplers) may be used to attach the active or passive grip interface assemblies to the testing machine. The load train couplers, in conjunction with the type of gripping device, play major roles in the alignment of the load train and thus subsequent bending imposed on the specimen. Load train couplers can be classified generally as fixed or non-fixed as discussed in the following sections. Note that the use of well-aligned fixed or self-aligned non-fixed couplers does not automatically guarantee low bending in the gage section of the tensile specimen. Generally, well-aligned fixed or self-aligning non-fixed couplers provide for well-aligned load trains, but the type and operation of grip interfaces as well as the as-fabricated dimensions of the tensile specimen can add significantly to the final bending imposed on the gage section of the specimen. Regardless of the type of load couplers chosen, they must be consistent with the thermal requirements imposed on them by the elevated temperature nature of creep testing. These requirements may preclude the use of some material combinations and load train designs.

6.3.2 *Fixed Load Train Couplers*—Fixed couplers may incorporate devices that require either a one-time, pretest alignment adjustment of the load train which remains constant for all subsequent tests or an in-situ, pretest alignment of the load train which is conducted separately for each specimen and each test. Such devices (11, 12) usually employ angularity and concentricity adjusters to accommodate inherent load train misalignments. Regardless of which method is used, alignment verification must be performed as discussed in 6.1.2.

6.3.3 *Non-Fixed Load Train Couplers*—Non-fixed couplers may incorporate devices that promote self-alignment of the load

train during the movement of the crosshead or actuator. Generally, such devices rely upon freely moving linkages to eliminate applied moments as the load train components are loaded. Knife edges, universal joints, hydraulic couplers, and air bearings are examples (7, 11, 13, 14, 15) of such devices. Although non-fixed load couplers are intended to be self-aligning and thus eliminate the need to evaluate the bending in the specimen for each test, the operation of the couplers must be verified as discussed in 6.1.2.

6.4 Heating Apparatus:

6.4.1 The apparatus for and method of heating the specimens must provide the temperature control necessary to satisfy the requirements specified in 6.4.2 without manual adjustments more frequent than once in each 24-h period after load application. It must also satisfy the requirements of the testing environment in 6.4.3.

6.4.2 *Temperature*—The furnace must be capable of maintaining the tensile specimen temperature constant with time to 2 K. The temperature readout device must have a resolution of 1 K or less. The furnace system must be such that thermal gradients are minimal in the tensile specimen so that no more than a 5-K differential exists in the specimen gage length at temperatures up to 1773 K.

6.4.3 *Environment*—The furnace may have an air, inert, or vacuum environment as required. If an inert or vacuum chamber is used, and it is necessary to direct load through bellows, fittings, or seal, then it must be verified that force losses or errors do not exceed 1 % of the applied force.

6.5 Temperature Measuring Devices :

6.5.1 The method of temperature measurement must be sufficiently sensitive and reliable to ensure that the temperature of the specimen is within the limits specified in 6.4.2. Depending on the temperature range being used, this can be accomplished with either calibrated thermocouples or pyrometers.

6.5.2 Thermocouples:

6.5.2.1 *Calibration*—The thermocouple(s) must be calibrated in accordance with Method E 220 and Tables E 230.⁸ For longer tests at higher temperatures, this must be done both before the test is initiated and after the test is completed in order to determine the extent of thermocouple degradation and possible thermal drift during the test.

6.5.2.2 *Accuracy*—The measurement of temperature must be accurate to within 5 K. This includes the error inherent to the thermocouple and any error in the measuring instruments.^{9,10}

6.5.2.3 *Extension Wire*—The appropriate thermocouple extension wire must be used to connect a thermocouple to the furnace controller or temperature readout device, or both. Special attention must be accorded to connecting the extension wire with the correct polarity.

6.5.2.4 *Degradation*—The integrity and degree of degradation of used bare thermocouples must be verified before each test. At certain temperatures, oxidation and elemental diffusion of the thermocouple alloys will affect the electromotive force (EMF) of the thermocouple junctions. As a consequence, the EMF of a bare, used thermocouple will no longer correspond to the calibration values determined in the pristine condition. The indicated temperature will therefore be less than the actual temperature. This is a particular problem when the same thermocouple is used for both monitoring and control of temperature. Previously used bare thermocouples must be replaced (with newly welded and annealed, or cut-back, rewelded, and annealed thermocouples) when calibration at the test temperature reveals an error of >2K. It is preferable to use fully sheathed thermocouples in order to minimize degradation.

6.5.3 Pyrometers:

6.5.3.1 *Calibration*—The pyrometer(s) must be calibrated in accordance with Test Method E 639.

6.5.3.2 *Accuracy*—The measurement of temperature must be accurate to within 5 K. This shall include the error inherent to the pyrometer and any error in the measuring instruments.^{9,10}

6.6 Extensometers:

6.6.1 The strain measuring equipment must be capable of being used at elevated temperatures. The sensitivity and accuracy of the strain-measuring equipment must be suitable to define the creep characteristics with the precision required for the application of the data.

6.6.2 *Calibration*—Extensometers must be calibrated in accordance with Practice E 83.

6.6.3 *Accuracy*—Extensometers with accuracies equivalent to the B-1 classification of extensometer systems specified in Practice E 83 are suitable for use in high-temperature testing of ceramics. Results of analytical and empirical evaluations at elevated temperatures show that mechanical extensometers (16) can meet these requirements. Optical extensometers using flags have gage length uncertainties that will generally prevent them from achieving class B-1 accuracy (187). Empirical evaluations at elevated temperature (198) show that these extensometers can yield highly repeatable creep data, however.

6.7 *Timing Apparatus*—For creep rupture tests, a timing apparatus capable of measuring the elapsed time between complete application of the load and the time at which fracture of the specimen occurs to within 1 % of the elapsed time shall be employed.

⁸ Thermocouples should be periodically checked since calibration may drift with usage or contamination.

⁹ Resolutions should not be confused with accuracy. Beware of instruments that readout to 1°C (resolution), but have an accuracy of only 10 K or ½ % of full scale (½ % of 1200 K is 6 K).

¹⁰ Temperature measuring instruments typically approximate the temperature-EMF tables, but with a few degrees of error.

7. Test Specimens and Sample

7.1 Specimen Size:

7.1.1 *Description*—The size and shape of test specimens must be based on the requirements necessary to obtain representative samples of the material being investigated. The specimen geometry shall be such that there is no more than a 5 % elastic stress concentration at the ends of the gage section. Typical shapes include square or rectangular cross-section dogbones and cylindrical button-head geometries, and are shown in Appendix X1. It is recommended, in accordance with Practice E 139 and in the absence of additional information to the contrary, that the grip section be at least four times larger than the larger dimension of either width or thickness of the gage section.

7.1.2 *Dimensions*—Suggested dimensions for tensile creep specimens that have been successfully used in previous investigations are given in Appendix X1. Cross-sectional tolerances are 0.05 mm. Parallelism tolerances on the faces of the specimen are 0.03 mm. Various radii of curvature may be used to adjust the gage section or change the mounting configuration. Although these radii are expected to be larger, resulting in a smaller stress concentration, wherever possible, resort should be made to a finite element analysis to determine the locations and intensities of stress concentrations in the new geometry.

7.2 *Specimen Preparation*—Depending on the intended application of the data, use one of the following specimen preparation procedures:

7.2.1 *Application-matched Machining*— The specimen must have the same surface preparation as that specified for a component. Unless the process is proprietary, the report must be specified about the stages of material removal, wheel grits, wheel bonding, and the amount of material removed per pass.

7.2.2 *Customary Procedure*—In instances where a customary machining procedure has been developed that is completely satisfactory for a class of materials (that is, it induces no unwanted surface damage or residual stresses), then this procedure shall be used. It shall be fully specified in the report.

7.2.3 *Standard Procedure*—In instances where 7.2.1 or 7.2.2 are not appropriate, then 7.2.3 will apply. This procedure will serve as the minimum requirements, but a more stringent procedure may be necessary.

7.2.3.1 *Grinding Process*—All grinding using diamond-grit wheels must be done with an ample supply of appropriate filtered coolant to keep workpiece and wheel constantly flooded and particles flushed. Grinding must be done in at least two stages, ranging from coarse to fine rates of material removal. All machining must be done in the surface grinding mode, and be parallel to the specimen long axis (several specimens are shown in the appendix). Do not use Blanchard or rotary grinding.

7.2.3.2 *Material Removal Rate*—The material removal rate must not exceed 0.03 mm (0.001 in.) per pass to the last 0.06 mm (0.002 in.) per face. Final and intermediate finishing must be performed with a resinoid-bonded diamond grit wheel that is between 320 and 600 grit. No less than 0.06 mm per face shall be removed during the final finishing phase, and at a rate of not more than 0.002 mm (0.0001 in.) per pass. Remove approximately equal stock from opposite faces.

7.2.3.3 *Precaution*—Materials with low fracture toughness and a high susceptibility to grinding damage may require finer grinding wheels at very low removal rates.

7.2.3.4 *Chamfers*—Chamfers on the edges of the gage section are preferred in order to minimize premature failures due to stress concentrations or slow crack growth. The use of chamfers and their geometry must be clearly indicated in the test report (see 10.1.1).

7.2.4 *Button-head Specimen-Specific Procedure*—Because of the axial symmetry of the button-head tensile specimen, fabrication of the specimens is generally conducted on a lathe-type apparatus. The bulk of the material is removed in a circumferential grinding operation with a final, longitudinal grinding operation performed in the gage section to ensure that any residual grinding marks are parallel to the applied stress. Beyond the guidelines stated here, more specific details of recommended fabrication methods for cylindrical tensile specimens can be found elsewhere (4).

7.2.4.1 *Computer Numerical Control (CNC) Precaution*—Generally CNC fabrication methods are necessary to obtain consistent specimens with the proper dimensions within the required tolerances. A necessary condition for this consistency is the complete fabrication of the specimen without removing it from the grinding apparatus, thereby avoiding building unacceptable tolerances into the finished specimen.

7.2.4.2 *Grinding Wheels*—Formed, resinoid-bonded, diamond-impregnated wheels (minimum 320 grit in a resinoid bond) are necessary to fabricate critical shapes (for example, button-head radius) and to minimize grinding vibrations and subsurface damage in the test material. The formed, resin-bonded wheels require periodic dressing and shaping (truing), which can be done dynamically, to maintain the cutting and dimensional integrity.

7.2.4.3 *Subsurface Damage*—The most serious concern is not necessarily the surface finish (on the order of $R_a = 0.2$ to $0.4 \mu\text{m}$) which is the result of the final machining steps. Instead, the subsurface damage is critically important although this damage is not readily observed or measured, and therefore, must be inferred as the result of the grinding history. More details of this aspect have been discussed in Ref. (4). In all cases, the final grinding operation (“spark out”) performed in the gage section must be along the longitudinal axis of the specimen to ensure that any residual grinding marks are parallel to the applied stress.

7.2.5 *Handling Precautions*—Care must be exercised in storing and handling of specimens to avoid the introduction of random and severe flaws, such as might occur if the specimens were allowed to impact or scratch each other. Specimens should be stored separately in cushioned containers to minimize the occurrence of these problems.

7.3 *Specimen Sampling and Number*—Samples of the material to provide test specimens must be taken from such locations so

as to be representative of the billet or lot from which it was taken. Although each testing scenario will vary, generally, a minimum of 24 specimens is required for the purpose of completely determining the creep and creep rupture behavior across a significant temperature and stress range. Typically, six specimens are run at each temperature of interest over the entire range of applied stresses of interest. Initial tests are used to define the range of temperature where creep is the dominant deformation mechanism, and the remainder are used to acquire more precise creep and creep-time-to-failure data. Variations from this number are permitted as necessary to meet limitations on the amount of material or other mitigating factors. A smaller number of specimens is permissible in cases where the ranges of applied stress or temperature, or both, are more narrow.

8. Procedures

8.1 *General:*

8.1.1 *Specimen Dimensions*—Determine the thickness, diameter, and width of the gage section of each specimen to within 1 % of its absolute value. In order to avoid damage in a critical area, carefully make the measurement using a flat, anvil-type micrometre. Ball-tipped or sharp anvil micrometres are not recommended because they can cause localized cracking. Use the measured dimensions to calculate the force required to achieve the desired stress in the gage section.

8.1.2 *Determination of Gage Length*—Determine the gage length of the specimen by points of attachment of the extensometer system being used. It should be as close to the length of the uniform cross section of the specimen as possible within the temperature variations stated in 6.4.2. It can be determined by any suitable optical or contact extensometry method. A number of such systems are available commercially. Make calibrations according to the appropriate manufacturer’s instructions and check periodically using independent means.

8.1.2.1 *Mounting Flags to the Specimen :*

(1) *Optical Method*—Attach two or ~~four~~ more flags of dimensions; suitable for the gage width and thickness chosen, to the specimen gage length. Typical flag dimensions for the flat specimen shown in the appendix are shown in Fig. 1. ~~The shows typical flags are made by cutting an angled slot at one end used for the specimens shown in Fig. X1.2 of a rectangular piece of a suitable high-temperature material (preferably the same material as Appendix. They can be made from the test specimen, material itself or sintered SiC, if the test material is not available), with an opening the size SiC. The depth of the specimen cross section. Place the slotted end of each flag around the gage section of the specimen, and secure using a room-temperature adhesive. The room-temperature adhesive holds the flags (dimension *d* in position during subsequent handling and will burn off Fig. 1) should be kept as the temperature is raised to the test temperature. When this happens, the flags are then held in place by friction. At elevated temperatures, oxidation secures the flags firmly to the gage section. ~~small as possible.~~~~

(2) *Contacting Method*—Setting of the initial gage length for a contacting extensometer depends on the extension measurement method (capacitance-based or strain gage-based), and the manufacturer’s procedures for setup must be followed. Position the

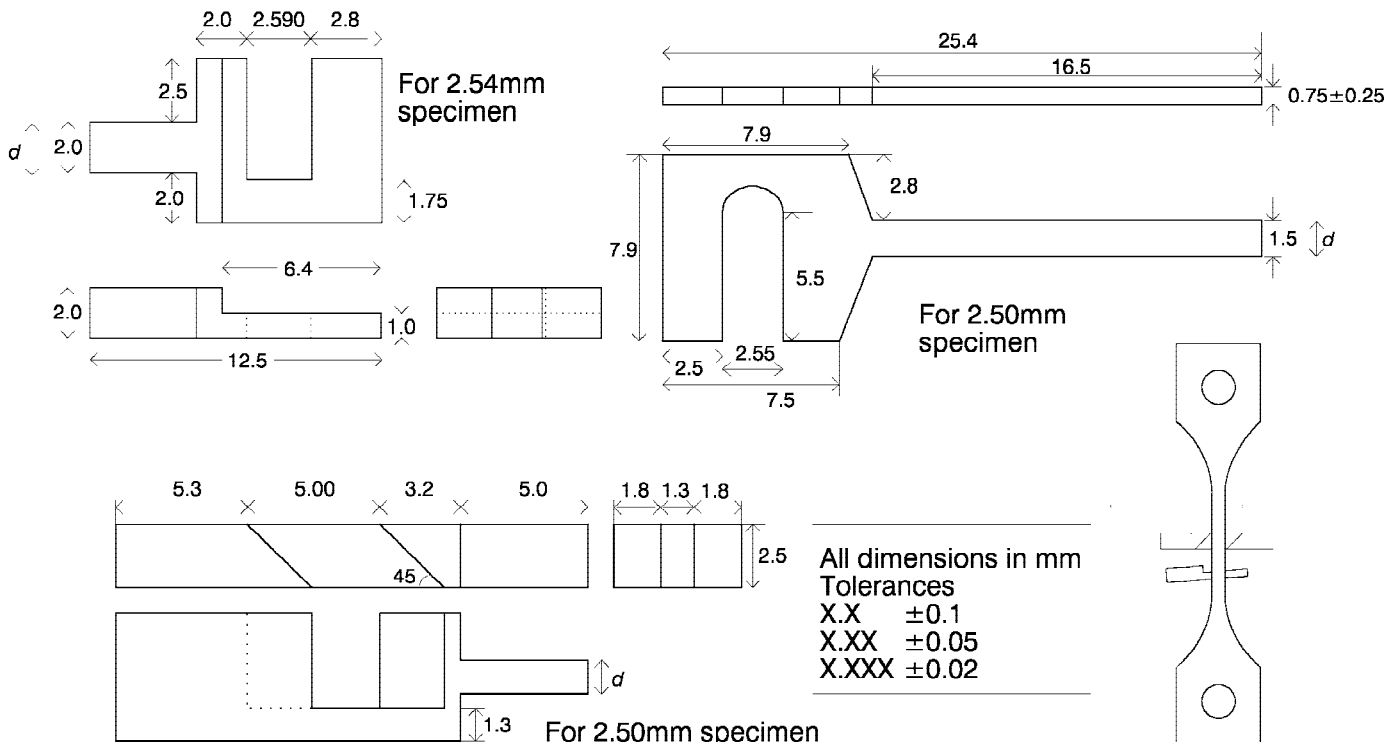

NOTE 1—Dimensions shown are in millimetres.

FIG. 1 Schematic of Flags for Flat Dogbone Specimens of Dimensions as Shown in the Appendix

extensometer probes with rounded knife-edge tips in contact with the specimen and hold in place with a light (0.1 to 1.0 N) contact force. A schematic of a contacting extensometer system is shown in Fig. 2. At elevated temperatures, oxidation at the probe/specimen interface minimizes slippage.

8.1.2.2 *Mounting the Specimen in the Furnace*—Mount specimens in the load train prior to heating the furnace. After the specimens are mounted in the load train, apply a small preload to maintain the load train alignment during subsequent heat-up to the test temperature. The preload should introduce a stress of no more than 5 MPa in the gage section. For specimens using contacting extensometry, make the extensometry settings prior to heating the furnace. The contacting probes may be left in contact with the specimen during heat-up or brought into contact with the specimen after it has reached the test temperature, depending on the testing setup.

8.1.2.3 *Heating to the Test Temperature :*

(1) *Specimens with Flags*—Specimens with flags may be heated to the test temperature in stages. The first stage, if required, takes the temperature to approximately 700 K to burn off the room temperature cement. The soak time at this temperature is about 1 h. The second stage takes the specimen to the test temperature at a rate of approximately 300 to 500 K/h, but may be as fast as 1000 K/h. The soak time at the test temperature is determined experimentally, and must be long enough to allow the entire system to reach thermal equilibrium. The total time for heating and soaking should be less than 24 h. State heating rates and soak times in the report.

(2) *Specimens Using Contacting Extensometers*—Specimens that utilize contact extensometry may be either heated from room temperature to the test temperature in a single stage and constant heating rate of up to 1000 K/h or may be heated from a preheat furnace temperature to the final test temperature. If the furnace is heated from room temperature to the test temperature, a soak time should be determined experimentally, and must be long enough to allow the entire system to reach thermal equilibrium. The total time for heating and soaking should be less than 24 h. State heating rates and soak times in the report.

8.1.2.4 *Use of Thermocouples:*

(1) Monitor specimen temperature using a thermocouple with its tip located no more than 2 mm from the surface midpoint of the tensile specimen. Use either a fully sheathed or exposed bead junction. If a sheathed tip is used, verify that there is negligible error associated with the covering.^{11,12}

(2) A separate thermocouple may be used to control the temperature of the furnace chamber if needed, but the specimen temperature shall be the reported temperature of the test.¹³

(3) For longer gage sections where spatial temperature variation may be of concern, take additional thermocouple temperature measurements at the top and bottom of the gage section.

8.1.2.5 *Calculating, Applying, and Recording the Force*—Based on the dimensions measured in 8.1.1, compute the preload force, F_p , needed to achieve the recommended 5 MPa stress in the gage section (see 8.1.2.2). Apply the preload in load control to accommodate the dimensional changes expected in the specimen and fixtures during heating. Compute the force, F , needed to achieve the desired applied stress, σ_a , in accordance with 9.1.1. After the test specimen has stabilized at the desired temperature, apply the desired creep force over a period of approximately 30 to 120 s to prevent premature failure. Measure and record the force at regular intervals during the test to ensure compliance with the requirements of 6.1.

8.1.2.6 *Recording of Displacement Data*— Record the displacement determined by the extensometry system at appropriate intervals using an appropriate data logger. The number of intervals shall be at least 100, and be appropriate to the expected duration

¹¹ This test method is under the jurisdiction of ASTM Committee C28 on Advanced Ceramics and is the direct responsibility of Subcommittee C28.01 on Properties and Performance.

Current edition approved Oct. 10, 2000. Published January 2001. Originally published as C 1291 – 95. Last previous edition 1291 – 00.

¹² The thermocouple tip may contact the tensile specimen, but only if it is certain that the thermocouple tip or sheathing material will not chemically interact with the specimen. Thermocouples are prone to breakage if they are in contact with the specimen.

¹³ Tensile tests are sometimes conducted in furnaces that have thermal gradients. It is essential to monitor the temperature at the specimen.

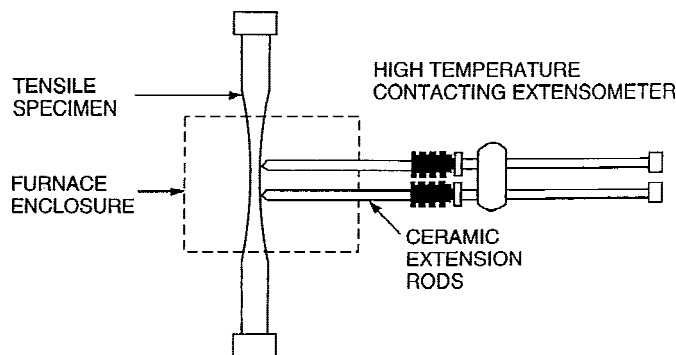

FIG. 2 Schematic of High-Temperature Contacting Extensometer System

of the test. It may be necessary to record displacement data more frequently at the start of the test, when the creep rate is often higher, than later into the test when the creep rate has decreased.

8.1.2.7 *Use of Strain-Gaged Specimens*— The occasional use of a strain-gaged specimen at room temperature is recommended to verify that there is negligible error due to bending. Do not leave strain gages on the specimen when the system is heated up, since they will melt or burn incompletely with the residue contaminating the specimen or fixture, or both.

8.1.2.8 *End of Test Criteria*—The end of a given test has occurred when any of the following conditions has been met: (1) the specimen fractures, (2) the specimen reaches a predetermined level of strain, or (3) the specimen has crept for a predetermined length of time. In Case 1, examine the fracture surfaces to determine whether or not the specimen failed in the gage section. In the event failure occurred outside of the measured gage section but within the uniform cross-sectional area, the test may still be valid. Use fractography, along with the knowledge of the testing apparatus and conditions, to determine what occurred at the failure point and make a determination of validity. In the event failure occurred outside of the measured gage section and outside of the uniform cross-sectional area, discard the test result. In the event that failure occurred at the extensometer contact points, use fractography to determine whether the specimen was affected by the contact. If it was affected, discard the test result. If it was not affected, use the result.

9. Calculation

9.1 Formulae:

9.1.1 The formulae for determining the force applied to the test specimen are, for rectangular cross sections:

$$F = \sigma_a wt \quad (1)$$

where σ_a is the applied stress, t is the thickness of the gage section, and w is the width of the gage section, and for circular cross sections:

$$F = \pi \sigma_a d^2 / 4 \quad (2)$$

where d is the diameter of the gage section.

9.1.2 The standard formulae for the gage section stresses in tensile specimens are stated in the following:
For rectangular cross sections,

$$\sigma_a = \frac{F}{wt} \quad (3)$$

where σ_a is the applied stress, F is the applied force, w is the width of the gage section, and t is the thickness of the gage section.
For circular cross sections,

$$\sigma_a = \frac{F}{\pi d^2 / 4} \quad (4)$$

where σ_a is the applied stress, F is the applied force, and d is the diameter of the gage section.

9.1.3 The creep strain of the specimen at any time is determined from:

$$\epsilon = (l - l_0) / l_0 \quad (5)$$

where l is the measured gage length and l_0 is the initial gage length under load and at temperature at the start of the creep measurement. l and l_0 must not include the elastic extension that occurs when the specimen is first loaded. Alternatively, the true creep strain curve can be obtained from a plot of $\ln l$ versus time where the y -axis is shifted to give zero creep strain at time zero, using

$$\epsilon = \ln (l / l_0) \quad (6)$$

9.1.4 The creep strain rate of the specimen at any point in time is determined by taking the tangent of the creep strain versus time curve. Creep strain rate can be calculated numerically using a suitable method such as a seven-point secant algorithm or as the derivative of the polynomial fit of the strain-time data (report the degree of polynomial fit and correlation coefficient).

10. Report of Test Results

10.1 Report the following information:

10.1.1 Test configuration and specimen size used.

10.1.2 The number of specimens (n) used.

10.1.3 The relevant material data including vintage, component, or billet identification data. (Did all specimens come from one component or plate?) As a minimum, report the date the material was manufactured.

10.1.4 The exact method of specimen preparation, including all stages of machining.

10.1.5 Heat treatments or exposures, if any.

10.1.6 Test temperature and environment. Method of specimen temperature measurement, including thermocouple type and distance of the thermocouple junction from the specimen, if applicable, and changes in thermocouple calibration in the case of long, high-temperature tests where degradation of the thermocouple might reasonably be expected.

10.1.7 Type of furnace, and environment (air, inert, vacuum, or other). The type of heating elements, and the temperature control device.

10.1.8 Rate of heating,

10.1.9 The soak or hold time at temperature prior to commencement of test.

10.1.10 The type of fixture used, including the material. Method and results of specimen alignment.

10.1.11 Method of specimen strain measurement, including calibration method and results.

10.1.12 Any deviations and alterations from the procedures specified.

10.1.13 Elastic modulus of the material at the test temperature (this can be determined by independent means, and need not be measured as part of this test method).

10.1.14 Plots of strain versus time for each test.

10.1.15 Plots of creep strain rate versus time for each test.

10.1.16 Minimum creep strain rate, applied stress, accumulated strain to failure, both with and without the elastic strain, and time to failure for each test.

10.2 Wherever possible, report the information in accordance with standard guidelines promulgated by ASTM Committee E-49 on Computerization of Material and Chemical Property Data.

11. Precision and Bias

11.1 *Interlaboratory Test Program*—There have been two interlaboratory studies on creep and rupture of structural ceramics. The first (198) employed only five laboratories, and thus does not warrant a formal precision and bias statement. It did, however, demonstrate that excellent repeatability and reproducibility are possible when laboratories test identical test specimens of an appropriate material. For instance, the between-laboratory coefficient of variation for \log_e of failure time was only 7.3 %. In that study, participants tested four specimens of NGK Insulators SN-88 to failure in air at 1400°C under a 150 MPa load. All participants used identical, pin-loaded 76 mm long specimens (20)(19). **All measured strain using flag-based laser extensometry. Typical failure times were 75 h.**

11.1.1 In a larger study during 1998–99 (210), 14 laboratories tested a later vintage of the same grade of silicon nitride. Of necessity, it employed several different test specimens, loading methods, and extensometry techniques, but followed the requirements of Practice E 691. The results of this study were more variable, both within and between laboratories, than the earlier five-laboratory study. In the larger interlaboratory study, the participants tested three specimens to failure at 1375°C in air under a 200 MPa load. Because the within-laboratory variability was larger for this study than for the previous one, specimen variability may have played a more important role.

11.2 *Test Result*—Table 1 shows the calculation for $\log_e(t_f)$, strain to failure ϵ_f , and \log_e of the minimum creep rate for the fourteen-laboratory 1998–99 study. Each laboratory tested three specimens to failure.

11.3 *Precision*—See Table 1. In this table, the repeatability standard deviation, s_r , is a measure of the scatter within a given laboratory. The reproducibility standard deviation is a measure of the variability between laboratories. The terms in Table 1 are used as specified in Practice E 177.

11.4 *Bias*—Because there is no accepted reference material, method, or laboratory suitable for determining the bias for the procedures in this test method for measuring tensile creep strain, creep strain rate, and creep time to failure, no statement on bias is being made.

12. Keywords

12.1 advanced ceramics; creep; monolithic ceramics; tensile; time-to-failure

TABLE 1 Precision of Creep Time-to-Failure (t_f), Strain to Failure (ϵ_f) and Minimum Creep Strain Rate ($\dot{\epsilon}_{min}$) from an Interlaboratory Round Robin^A

Test	Average	Repeatability	Reproducibility	Repeatability	Reproducibility	Within-laboratory	Between-laboratory
		Standard Deviation	Standard Deviation	Limit	Limit	Coefficient of Variation	Coefficient of Variation
		s_r	s_R	r	R	%	%
$\log_e(t/h)$	4.642	0.704	1.436	1.951	3.981	15.2	30.9
ϵ_f	0.0199	0.0078	0.0119	0.0216	0.0331	39.3	60.1
$\log_e(\dot{\epsilon}_{min}/1/s)$	-17.325	0.437	0.906	1.211	2.512	2.5	5.2

^AThis table was calculated using the relationship: limit = $1.96\sqrt{2} \times$ std deviation.

APPENDIXES

(Nonmandatory Information)

X1. GEOMETRIES AND DIMENSIONS OF TYPICAL TENSILE CREEP SPECIMENS

X1.1 This appendix describes the geometries and dimensions of several samples that have been used successfully in tensile creep testing. It is by no means an exhaustive description of possible specimen geometries.

X1.2 Definitions

X1.2.1 *button-head specimen*— a cylindrical, uniform-gaged specimen that has buttonhead-shaped mounting ends.

X1.2.2 *flat, dogbone specimen*— a flat, tabbed specimen that tapers from the tabs to a uniform square or rectangular cross section for the gage length.

X1.3 Specimen Geometries

X1.3.1 *Button-head Specimen*— The dimensions of a typical specimen for the buttonhead geometry are shown in Fig. X1.1. Note that the drawing shown is for illustrative purposes only, and is not a complete engineering drawing.

X1.3.2 *Flat, Dogbone Specimen*— Typical flat, dogbone specimens with and without integrally machined flags are shown in Fig. X1.2. The cross-sectional tolerance is ± 0.05 mm. The parallelism tolerance on the faces of the specimen is ± 0.03 mm. There is a double reduction of the gage section in going from the tab end to the gage section to reduce stress concentrations. The loading holes at each end, as shown in Fig. X1.2, are tapered at an angle of 15° to minimize front-to-back bending of the specimen.

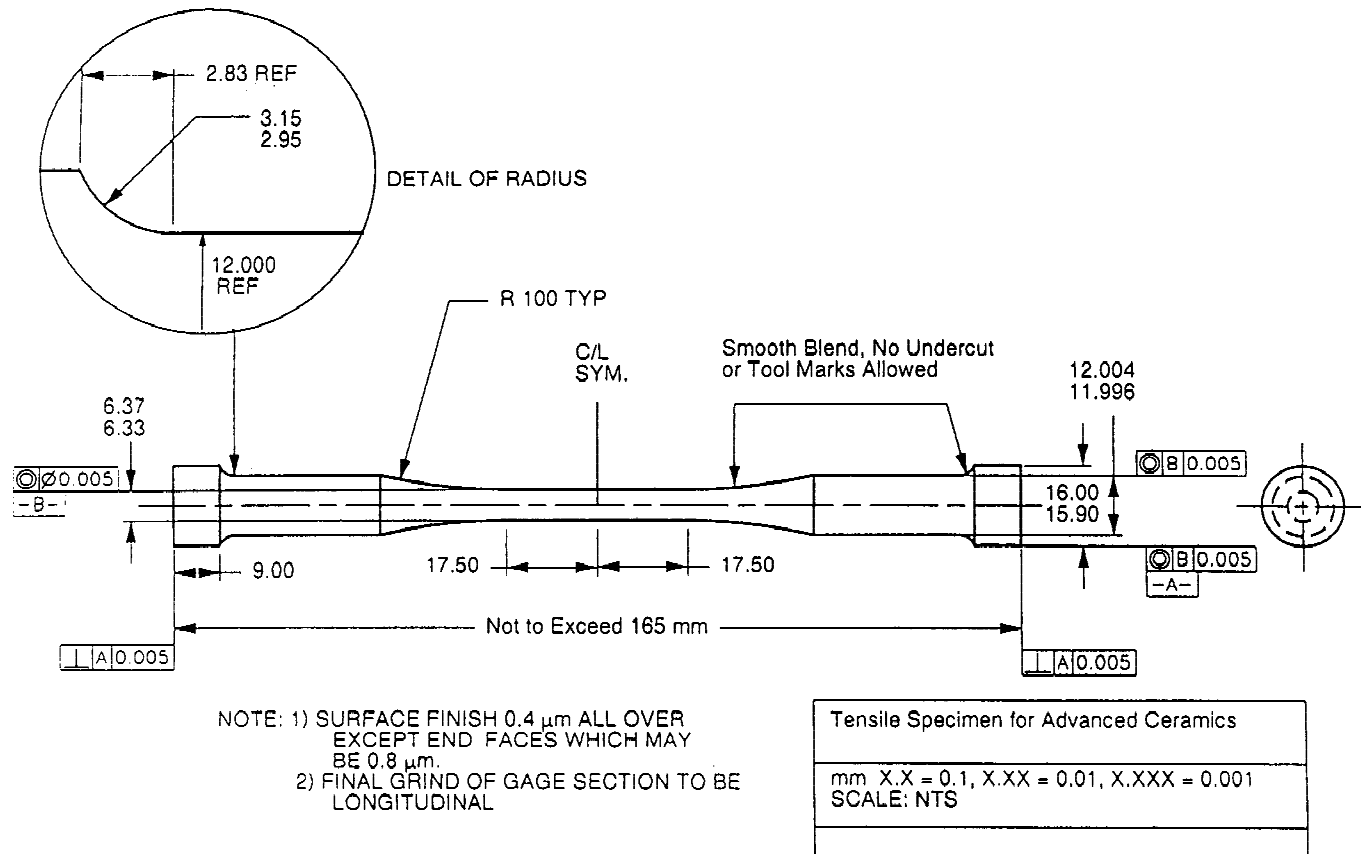

NOTE 1—Dimensions shown are in millimetres.

FIG. X1.1 Schematic of Cylindrical Specimen for Button-head Geometry

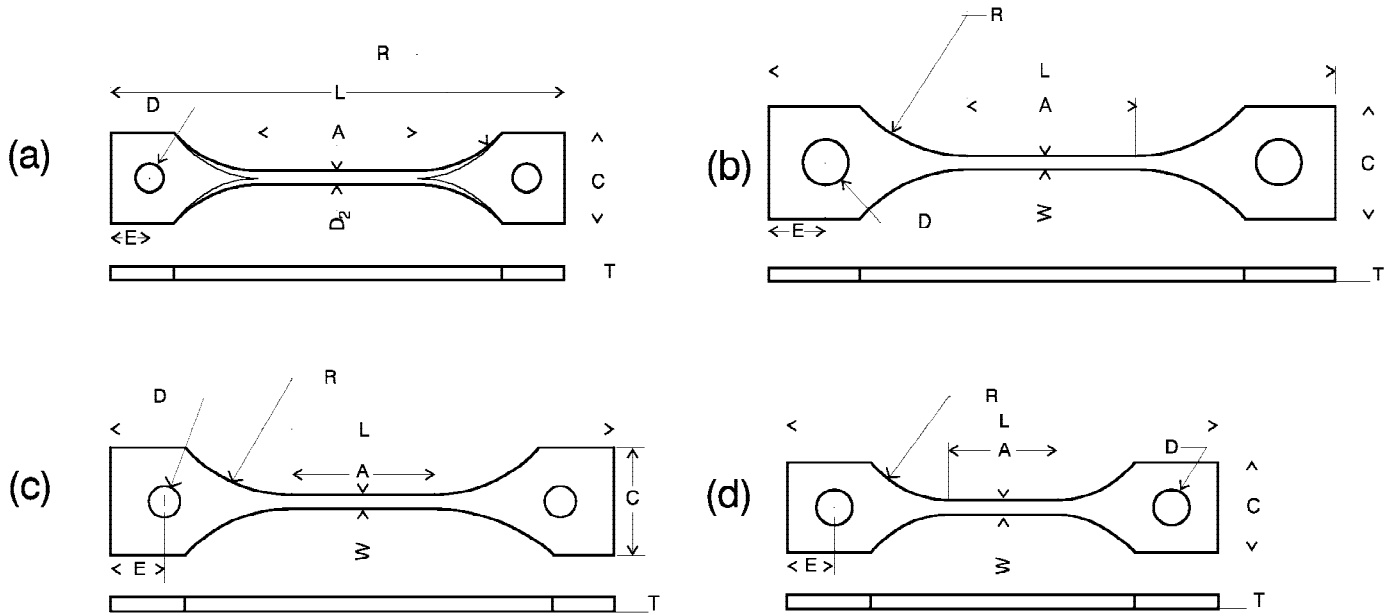

FIG. X1-2 Schematics of Typical Flat, Dogboned Specimens that have been Successfully Employed in Tensile Test Creep-Dep Experiments at Room Temperature.

Specimen Dimension (mm)	Specimen			
	a	b	c	d
L—Over-all length	80	100.0	88.9	76.2
A—Length of reduced section	28.0	30.0	25.4	19.04
D ₂ —Diameter	2.50 ^a			
W—Width		2.50	2.50	2.54
T—Thickness	2.50	2.5	2.50	2.54
C—Width of grip Section	16.0	20.0	19.0	15.88
R—Radius of fillet	20.0	25.0	25.4	19.04
D—Diameter of the hole for pin	5.0	8.0	5.5	6.35
E—Edge distance for pin	6.73	10.0	9.52	8.26

^aNote that specimen (a) has a cylindrical cross section.

X2. VERIFICATION OF LOAD TRAIN BENDING

X2.1 Purpose of Verification

X2.1.1 The purpose of this verification procedure is to demonstrate that the grip interface and load train couplers can be used by the test operator in such a way as to consistently meet the limit on percent bending as specified in Section 6. Thus, this verification procedure should involve no more care in setup than will be used in the routine testing of the actual tensile specimen. The bending under tensile load should be measured using verification (or actual) specimens of exactly the same design as that to be used for the tensile creep and creep rupture tests. For the verification purposes, strain gages should be applied as shown in Fig. X2.1. Verification measurements should be conducted (1) at the beginning and end of a series of tests with a measurement at the midpoint of the series recommended, (2) whenever the grip interfaces and load train couplers are installed on a different test machine, (3) whenever a different operator is conducting a series of tests, and (4) whenever damage or misalignment is suspected. Since the verification specimen uses adhesively bonded strain gages, the verification procedure is to be conducted at room temperature with the implication that the load train alignment will remain constant at high temperatures.

X2.2 Verification Specimen

X2.2.1 The specimen used for verification must be machined carefully with attention to all tolerances and concentricity requirements. Ideally, the verification specimen should be of identical material to that being tested. However, if this is not possible or desired, an alternative material with similar elastic modulus, elastic strain capability, hardness, etc., to the test material should be used. The specimen should be carefully inspected with an optical comparator before strain gages are attached to ensure that these requirements are met. After the strain gages are applied, it will no longer be possible to meaningfully inspect the specimen, so care should be exercised in handling and using it.

X2.2.1.1 For simplicity in applying this test method to test specimens with both circular and rectangular cross section gage

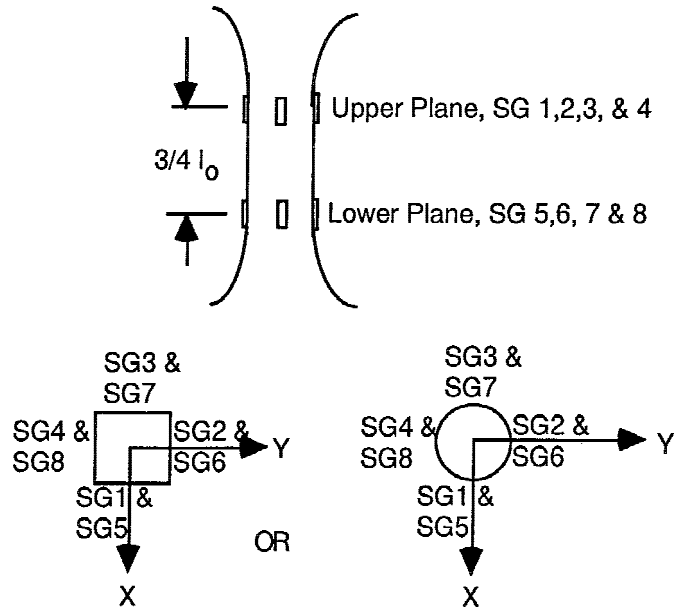

FIG. X2.1 Illustration of Strain Gages and Orthogonal Axes on Gage Section and Cross Sections on Tensile Specimens

sections, a minimum of eight foil-resistance strain gages should be mounted on the verification specimen as shown in Fig. X2.1. Note that the strain gage planes should be separated by at least $\frac{3}{4} l_0$ where l_0 is the length of the reduced or designated gage section. In addition, care must be taken to select the strain gage planes to be symmetrical about the longitudinal midpoint of the gage section. Avoid placing the strain gages closer than one strain gage length from geometrical features such as the transition radius from the gage section. These strain gages should be as narrow as possible to minimize strain averaging. Strain gages having active widths of 0.25 to 0.5 mm and active length of 1.0 to 2.5 mm are commercially available and are suitable for this purpose (4). Four strain gages, equally spaced (90° apart) around the circumference of the gage section, should be mounted at each of the two planes at either end of the gage section. These planes should be symmetrically located about the longitudinal midpoint of the gage section. Note that care should be taken to avoid placing the strain gages too near geometric transitions in the gage section which can cause strain concentrations and inaccurate measurements of the strain in the uniform gage section. In addition, to minimize errors due to misalignment of the strain gages, strain gages should be mounted such that the sensing direction is $\pm 2^\circ$ of the longitudinal axis of the specimen.

X2.3 Verification Procedure

X2.3.1 Procedures for verifying alignment are described in detail in Practice E 1012. However, salient points for square and circular cross sections are described here for emphasis. For rectangular cross sections, especially when the thickness is too thin to strain gage all four sides, consult Practice E 1012 for specific details.

X2.3.1.1 Mount the top of the specimen in the grip interface.

X2.3.1.2 Connect the lead wires of the strain gages to the conditioning equipment and allow the strain gages to equilibrate under power for at least 30 min prior to conducting the verification tests. This will minimize drift during actual conduct of the verifications.

X2.3.1.3 Zero the strain gages before mounting the bottom of the specimen in the grip interface. This will allow any bending due to the grips to be recorded.

X2.3.1.4 Mount the bottom of the specimen in the grip interface.

X2.3.1.5 Apply a sufficient load to the specimen to achieve an average strain of one half the anticipated fracture strain of the test material. Note that it is desirable to record the strain (and hence percent bending) as functions of applied load to monitor any self-alignment of the load train.

X2.3.1.6 Calculate the percent bending as follows, referring to Fig. X2.1 for the strain gage numbers. Percent bending at the upper plane of the gage section is calculated as follows:

$$PB_{\text{upper}} = \frac{\epsilon_b}{\epsilon_0} \times 100 \quad (\text{X2.1})$$

$$\epsilon_b = \left[\left(\frac{\epsilon_1 - \epsilon_3}{2} \right)^2 + \left(\frac{\epsilon_2 - \epsilon_4}{2} \right)^2 \right]^{1/2} \quad (\text{X2.2})$$

$$\epsilon_0 = \frac{(\epsilon_1 + \epsilon_2 + \epsilon_3 + \epsilon_4)}{4} \quad (X2.3)$$

where ϵ_1 , ϵ_2 , ϵ_3 , and ϵ_4 are strain readings for strain gages located at the upper plane of the gage section. Note that strain gage readings are in units of strain and compressive strains are considered to be negative.

X2.3.1.7 The direction of the maximum bending strain on the upper plane is determined as follows:

$$\theta_{\text{upper}} = \arctan \left[\frac{\epsilon_{(\text{next greatest of 1,2,3,4})} - \epsilon_0}{\epsilon_{(\text{greatest of 1,2,3,4})} - \epsilon_0} \right] \quad (X2.4)$$

where θ_{upper} is measured from the strain gage with the greatest reading in the direction of the strain gage with the second greatest reading where counter clockwise is positive.

X2.3.1.8 Percent bending at the lower plane of the gage section is calculated as follows:

$$PB_{\text{lower}} = \frac{\epsilon_b}{\epsilon_0} \times 100 \quad (X2.5)$$

$$\epsilon_b = \left[\left(\frac{\epsilon_5 - \epsilon_7}{2} \right)^2 + \left(\frac{\epsilon_6 - \epsilon_8}{2} \right)^2 \right]^{1/2} \quad (X2.6)$$

$$\epsilon_0 = \frac{(\epsilon_5 + \epsilon_6 + \epsilon_7 + \epsilon_8)}{4} \quad (X2.7)$$

where ϵ_5 , ϵ_6 , ϵ_7 , and ϵ_8 are strain readings for strain gages located at the lower plane of the gage section. Note that strain gage readings are in units of strain and compressive strains are considered to be negative.

X2.3.1.9 The direction of the maximum bending strain on the lower plane is determined as follows:

$$\theta_{\text{lower}} = \arctan \left[\frac{\epsilon_{(\text{next greatest of 5,6,7,8})} - \epsilon_0}{\epsilon_{(\text{greatest of 5,6,7,8})} - \epsilon_0} \right] \quad (X2.8)$$

where θ_{lower} is measured from the strain gage with the greatest reading in the direction of the strain gage with the second greatest reading where counter clockwise is positive.

X2.3.1.10 Note that for the following comparisons, θ_{upper} and θ_{lower} should be adjusted to reference the same point on the circumference. Since Strain Gages 1 and 5 fall on the same longitudinal line around the circumference, for consistency, these can be used as reference points for θ_{upper} and θ_{lower} , respectively. For example, on the upper plane, if Strain Gage 2 is the greatest measured strain with Strain Gage 3 being the next greatest measured strain, the direction of the maximum bending strain with reference to Strain Gage 1 is $\theta_{\text{upper}} + 90^\circ$ in the counterclockwise direction (that is, from Strain Gage 1 to 2). For uniform bending across the gage section with the specimen assuming a C-shape, $PB_{\text{upper}} \approx PB_{\text{lower}}$ and $|\theta_{\text{upper}} - \theta_{\text{lower}}| \approx 0^\circ$. C-shape bending reflects angular misalignment of the grips. For nonuniform bending across the gage section, with the specimen assuming an S-shape, PB_{upper} may or may not be equal to PB_{lower} and $|\theta_{\text{upper}} - \theta_{\text{lower}}| = 180^\circ$. S-shape bending reflects eccentric misalignment of the grip centerlines. These general tendencies are shown in Fig. X2.2. Combinations of C and S shapes may exist where $|\theta_{\text{upper}} - \theta_{\text{lower}}|$ is some angle between 0 and 180° . In these cases, the S-shape should first be eliminated by adjusting the concentricity of the grips such that the longitudinally aligned strain gages indicate approximately the same values (for example, $\epsilon_1 \approx \epsilon_5$, $\epsilon_2 \approx$

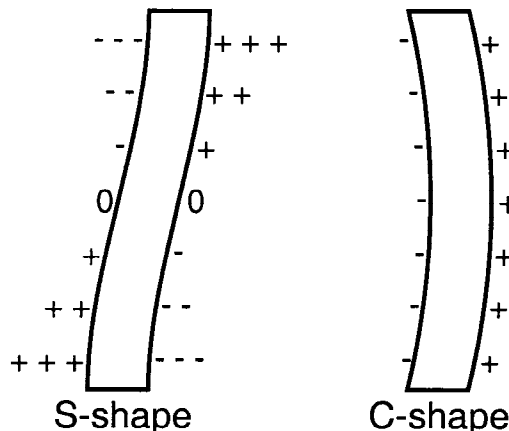

FIG. X2.2 S-shape and C-shape Bending of Tensile Creep and Creep Rupture Specimen

ϵ_6 , etc.). More detailed discussions regarding bending and alignment are contained in Ref (221) .

X2.3.1.11 The effect of specimen warpage can be checked by rotating the specimen 90° about its longitudinal axis and performing the bending checks again. These checks can be repeated for subsequent 90° rotations until a 360° rotation of the specimen has been achieved. If similar results are obtained at each rotation, then the degree of alignment is considered representative of the load train and not indicative of the specimen. If load train alignment is within the specifications of 6.1, the maximum percent bending should be recorded and the tensile creep or creep rupture test may be conducted. If the load train alignment is outside the specifications of 6.1, then the load train must be aligned or adjusted in accordance with the specific procedures unique to the individual testing setup. This verification procedure must then be repeated to confirm the achieved alignment.

X3. SOURCES AND EFFECTS OF EXPERIMENTAL ERRORS

X3.1 This appendix describes the sources and effects of several experimental errors that can occur in this test method. The sources of error include misalignment of the specimen, thermal expansion of the flags in optical extensometry systems, and thermal expansion in contacting extensometry systems.

X3.1.1 *Misalignment*—In the tensile testing of brittle materials, misalignment of the load train can cause bending strains that may lead to reduced measured strengths in comparison to results achieved from tests with proper uniaxial alignment. Such misalignment may result from (1) nonconcentricity between the major axis of the specimen and load train linkage, (2) types of pull-rod connectors used within the furnace, and (3) types of collet materials used in conjunction with the button-head grip. A review paper by Christ and Swanson (232) identifies numerous causes of misalignment and provides examples of methods to minimize bending moments introduced by the load train.

X3.1.2 Generally, maximum bending in the specimen gage section should be maintained at less than 5 % of the uniaxial strain (stress). Although analytical assessments of the effects of bending on Weibull parameters have been conducted for fast fracture tensile strength distributions (243), no such analyses have been conducted for allowable bending under conditions of general deformation such as creep testing.

X3.1.3 The degree of misalignment (bending) in the specimen gage section must be quantified and reported so as to provide a measure of the uniformity of the applied tensile stress. This should be performed on a sufficient number of specimens to ensure reproducibility of results, not on every specimen.

X3.1.4 Percent bending (PB) is currently the more common method of reporting the degree of bending strain and is calculated as a percentage of the average uniaxial strain at a given cross-sectional plane in the gage section. However, since PB is a percentage of the average applied axial strain, it is inherently load dependent and, thus may not be truly indicative of the actual degree of bending in the gage section. In general though, PB is defined as:

$$PB = \frac{\epsilon_b}{\epsilon_0} \times 100 \quad (X3.1)$$

where ϵ_b is the maximum bending strain and ϵ_0 is the average axial strain. The maximum bending strain may be calculated typically from three or four longitudinal strain gages such that:

For three strain gages (25, 26)(24, 25):

$$\epsilon_b = \sqrt{2/3[(\epsilon_1 - \epsilon_2)^2 + (\epsilon_2 - \epsilon_3)^2 + (\epsilon_1 - \epsilon_3)^2]^{1/2}} \quad (X3.2)$$

and

$$\epsilon_0 = (\epsilon_1 + \epsilon_2 + \epsilon_3)/3 \quad (X3.3)$$

For four strain gages (2423, see also Practice E 1012):

$$\epsilon_b = \left\{ \left(\frac{\epsilon_1 - \epsilon_3}{2} \right)^2 + \left(\frac{\epsilon_2 - \epsilon_4}{2} \right)^2 \right\}^{1/2} \quad (X3.4)$$

and

$$\epsilon_0 = (\epsilon_1 + \epsilon_2 + \epsilon_3 + \epsilon_4)/4 \quad (X3.5)$$

where ϵ_1 , ϵ_2 , ϵ_3 , and ϵ_4 are strain readings for strain gages located equi-spaced and sequentially around the circumference of the same cross-sectional plane of the gage section as shown in Fig. X2.1. Note that strain gage readings are in units of strain and compressive strains are considered to be negative.

X3.1.5 A common source of misalignment in the pin and clevis arrangement for the flat dogbone specimen occurs when the pin used to attach the tensile specimen to the loading rods loads preferentially on the edge of the attachment holes. This type of

misalignment produces a bending moment about the major face of the tensile specimen. To minimize this type of bending, the holes are tapered so that load is applied only to the center of the specimen. Alignment about the minor face of the specimen is determined by the accuracy with which the holes are machined to the centerline of the specimen. The analysis of Christ and Swanson (18)(22) can be used to estimate the tolerances needed in machining the holes on the centerline. If the centers of the holes are offset from the centerline by 0.025 mm (0.001 in.), a bending stress equal to about 5 % of the applied stress would be introduced into the gage section of the specimen. Although based on a simple elastic analysis, this calculation of the bending stress indicates the machining tolerances needed to obtain good alignment in the tensile specimen.

X3.1.6 Regardless of which measure of bending is used, the method, quantity of bending, and corresponding load at which the bending was measured should all be reported.

X3.2 *Thermal Expansion Related to Flags*—Thermal expansion may cause changes in the dimensions of the flags which could result in errors, if the flags do not all behave identically. Thermal expansion differences could arise from thermal gradients in the furnace or differences in the properties of the flag material, or both. These errors would result in errors in the measured gage length. Based on the requirements of the heating apparatus of 6.4, an estimate of the error in the gage length due to thermal expansion error can be made according to:

$$\frac{\Delta(\Delta l)}{l_0} = \frac{\Delta\alpha\Delta T}{l_0} \quad (X3.6)$$

For a gage length of 25 mm, a thermal expansion coefficient of 2 by 10^{-6} K^{-1} , and a 1-K thermal gradient, the difference between the actual and the true gage lengths is 2 by 10^{-6} , resulting in an error of 0.0002 % in the measured strain.

X3.3 *Thermal Expansion Related to Contacting Extensometers*—Due to the nature of the extensometer systems with remote sensing components at room temperature and sensing probes in contact with the hot specimen, thermal expansion of the extensometer components may provide two significant sources of error (226) : a finite shift or fluctuations in the output signal. Generally, the finite shift is due to thermo-mechanical dimensional changes and can be corrected either electronically before the commencement of testing or digitally from stored data files. A potentially more troublesome problem is fluctuations of the output signal due to a real temperature fluctuation in either the ambient temperature, grip cooling water temperature, or actual furnace temperature. Ambient temperature fluctuations can affect strain measurements either directly by affecting the remote strain sensors and related electronics, or indirectly by affecting the load cells or electronic load controllers. Grip cooling water fluctuations can affect the specimen length by affecting the temperature gradients in the specimens. Actual furnace temperature fluctuations will cause changes in both specimen length and extensometer outputs.

REFERENCES

- (1) Wiederhorn, S. M., Roberts, D. E., Chuang, T. J., and Chuck, L., "Damage-Enhanced Creep in Siliconized Silicon Carbide: Phenomenology," *J. Am. Ceram. Soc.*, Vol 71 [7], 1988, pp. 602–608.
- (2) Morrell, R., and Ashbee, K. H. G., High Temperature Creep of Lithium Zinc Silicate Glass-Ceramics-Part I, General Behavior and Creep Mechanisms," *J. Mater. Sci.*, Vol 8, 1973, pp. 1253–1270.
- (3) Wiederhorn, S. M., Chuck, L., Fuller, E. R., Jr., and Tighe, N. J., "Creep Rupture of Siliconized Silicon Carbide," *Tailoring of Multiphase and Composite Ceramics*, Materials Science and Research, Vol 20, R. E. Tressler, G. L. Messing, C. G. Pantano, and R. E. Newnham, eds., Plenum Press, New York, NY, 1986, pp. 755–773.
- (4) Chen, I. W., and Bowman, K., "Dynamic Fatigue Testing of Advanced Structural Ceramics," *Closed Loop*, Vol 17 [1], 1988, pp. 3–8.
- (5) Lin, C. K. J., Mayer, T. A., and Socie, D. F., "Cyclic Fatigue of Alumina," *Cyclic Deformation, Fracture, and Nondestructive Evaluation of Advanced Materials*, STP 1152, M. R. Mitchell, and O. Buck, eds., ASTM, Philadelphia, PA, 1992, pp. 3–27.
- (6) Jenkins, M. G., Ferber, M. K., Martin, R. L., Jenkins, V. T., and Tennery, V. J., "Study and Analysis of the Stress State in a Ceramic Button-Head, Tensile Specimen," Oak Ridge National Laboratory Technical Memorandum, ORNL/TM 111767, September 1991.
- (7) Ohji, T., "Towards Routine Tensile Testing," *Int. J. High. Tech. Ceramics*, Vol 4, 1988, pp. 211–225.
- (8) Seshadri, S. G., and Chia, K. Y., "Tensile Testing Ceramics," *J. Amer. Ceram. Soc.*, Vol 70 [10], 1987, pp. C 242–C244.
- (9) Wu, F. J., and Wade, J. A., "Predicting Creep Behavior of Silicon Nitride Ceramics Using Finite Element Techniques," *Life Prediction Methodologies and Data for Ceramic Materials*, STP 1201, C. R. Brinkman and S. F. Duffy, eds., ASTM, Philadelphia, PA, 1993.
- (10) D. F. Carroll, S. M. Wiederhorn and D. E. Roberts, "Technique for Tensile Creep Testing of Ceramics," *J. Am. Ceram. Soc.*, Vol 72, 1989, pp. 1610–1614.
- (11) Amaral, J. E., and Pollack, C. N., "Machine Design Requirements for Uniaxial Testing of Ceramic Materials," *Mechanical Testing of Engineering Ceramics at High Temperatures*, B. F. Dyson, R. D. Lohr, and R. Morrell, eds., Elsevier, New York, NY, 1989, pp. 51–68.
- (12) Mosiman, L. G., Wallenfelt, T. L., and Larsen, C. G., "Tension/Compression Grips for Monolithic Ceramics and Ceramic Matrix Composites," *Cer. Eng. Sci. Proc.*, Vol 12 [7–8], 1991.
- (13) Liu, K. C., and Brinkman, C. R., "Tensile Cyclic Fatigue of Structural Ceramics," *Proceedings of the 23rd Annual Automotive Technology Development Contractors' Coordination Meeting*, P-165, SAE, Warrendale, 1986, pp. 279–284.
- (14) Meijja, L. C., "High Temperature Tensile Testing of Advanced Ceramics," *Cer. Eng. Sci. Proc.*, Vol 10 [7–8], 1989, pp. 668–681.
- (15) Pears, C. D., and Starrett, H. W., "An Experimental Study of Weibull Volume Theory," AFML-TR-66-228, Air Force Materials Laboratory, Wright Patterson AFB, OH, 1967.

- (16) Liu, K. C., and Ding, J. L., “Mechanical Extensometer for High Temperature Tensile Testing of Ceramics,” *J. Test Eval.*, Vol 21 [5], 1993, pp. 406–413.
- (17) Pih, H., and Liu, K. C., “Laser Diffraction Methods for High Temperature Strain Measurements,” *Experimental Mechanics*, Vol 31 [1], 1991, pp. 60–64.
- (18) W. E. Luecke and J. D. French, “Sources of Strain Measurement Error in Flag-Based Extensometry,” *J. Am. Ceram. Soc.*, Vol 79 [6], 1996, pp. 1617–1626.
- (19) W. E. Luecke and S. M. Wiederhorn, “Interlaboratory Verification of Silicon Nitride Tensile Creep Properties,” *J. Am. Ceram. Soc.*, Vol 80 [4], 1997, 831–838.
- (20) J. D. French and S. M. Wiederhorn, “Tensile Specimens from Ceramic Components,” *J. Am. Ceram. Soc.*, Vol 79 [2], 1996, pp. 550–552.
- (21) W.E. Luecke, in preparation for publication; (2000-)
- (22) Larsen, C. G., “Ceramics Tensile Grip,” *STP 1080*, J. M. Kennedy, and H. M. Moeller, eds., ASTM, Philadelphia, PA, 1990, pp. 235–246.
- (23) Christ, B. W., and Swanson, S. R., “Alignment Problems in the Tensile Test,” *J. Test. Eval.*, Vol 4 [6], 1976, pp. 405–417.
- (24) Jones, M. H., and Brown, W. F., Jr., “Note on Performance of Tapered Grip Tensile Loading Devices,” *J. Test. Eval.*, Vol 3 [3], 1975, pp. 179–181.
- (25) Grant C., “Axiality of Loading in the Tensile Test,” *J. Strain Analysis*, Vol 7 [4], 1972, pp. 261–265.
- (26) Lange, F. F., and Diaz, E. S., “Powder Cushion Gripping to Promote Good Alignment in Tensile Testing,” *J. Testing Eval.*, Vol 6 [5], 1978, pp. 320–323.
- (27) Osgerby, S, Kandil, F. A., and Gibbons, T. B., “Testing of Ceramics in Tension at High Temperature: A Harmonized Approach,” *Harmonization of Testing Practice for High Temperature Materials*, M. S. Loveday, and T. B. Gibbons, eds., Elsevier Applied Science, New York, NY, 1992, pp. 273–283.

ASTM International takes no position respecting the validity of any patent rights asserted in connection with any item mentioned in this standard. Users of this standard are expressly advised that determination of the validity of any such patent rights, and the risk of infringement of such rights, are entirely their own responsibility.

This standard is subject to revision at any time by the responsible technical committee and must be reviewed every five years and if not revised, either reapproved or withdrawn. Your comments are invited either for revision of this standard or for additional standards and should be addressed to ASTM International Headquarters. Your comments will receive careful consideration at a meeting of the responsible technical committee, which you may attend. If you feel that your comments have not received a fair hearing you should make your views known to the ASTM Committee on Standards, at the address shown below.

This standard is copyrighted by ASTM International, 100 Barr Harbor Drive, PO Box C700, West Conshohocken, PA 19428-2959, United States. Individual reprints (single or multiple copies) of this standard may be obtained by contacting ASTM at the above address or at 610-832-9585 (phone), 610-832-9555 (fax), or service@astm.org (e-mail); or through the ASTM website (www.astm.org).