



Designation: C ~~1292—95a~~ 1292 – 00

Standard Test Method for Shear Strength of Continuous Fiber-Reinforced Advanced Ceramics at Ambient Temperatures¹

This standard is issued under the fixed designation C 1292; the number immediately following the designation indicates the year of original adoption or, in the case of revision, the year of last revision. A number in parentheses indicates the year of last reapproval. A superscript epsilon (ϵ) indicates an editorial change since the last revision or reapproval.

1. Scope

1.1 This test method covers the determination of shear strength of continuous fiber-reinforced ceramic composites (CFCCs) at ambient temperature. The test methods addressed are (1) the compression of a double-notched specimen to determine interlaminar shear strength and (2) the Iosipescu test method to determine the shear strength in any one of the material planes of laminated composites. Specimen fabrication methods, testing modes (load or displacement control), testing rates (load rate or displacement rate), data collection, and reporting procedures are addressed.

1.2 This test method is used for testing advanced ceramic or glass matrix composites with continuous fiber reinforcement having uni-directional (1-D) or bi-directional (2-D) fiber architecture. This test method does not address composites with (3-D) fiber architecture or discontinuous fiber-reinforced, whisker-reinforced, or particulate-reinforced ceramics.

1.3 The values stated in SI units are to be regarded as the standard and are in accordance with Practice E 380.

1.4 *This standard does not purport to address all of the safety concerns, if any, associated with its use. It is the responsibility of the user of this standard to establish appropriate safety and health practices and determine the applicability of regulatory limitations prior to use.* Specific hazard statements are given in 8.1 and 8.2.

2. Referenced Documents

2.1 *ASTM Standards:*

C 1145 Terminology ~~on~~ of Advanced Ceramics²

[†] These

¹ This test method is under the jurisdiction of ASTM Committee C-28 on Advanced Ceramics and is the direct responsibility of Subcommittee C28.07 on Ceramic Matrix Composites.

Current edition approved ~~Sept. 10, 1995~~ April 10, 2000. Published ~~November 1995~~ July 2000. Originally published as C 1292 – 95. Last previous edition C 1292 – 95a.

- D 695 Test Method for Compressive Properties of Rigid Plastics³
 D 3846 Test Method for In-Plane Shear Strength of Reinforced Plastics⁴
 D 3878 Terminology of for High-Modulus Reinforcing Fibers and Their Composites⁵
 D 5379/D 5379M Test Method for Shear Properties of Composite Materials by the V-Notched Beam Method⁵
 E 4 Practices for Force Verification of Testing Machines⁶
 E 6 Terminology Relating to Methods of Mechanical Testing⁶
 E 122 Practice for Choice of Sample Size to Estimate a Measure of Quality for a Lot or Process⁷
 E 177 Practice for Use of the Terms Precision and Bias in ASTM Test Methods⁷
 E 337 Test Method for Measuring Humidity with Psychrometer (The Measurement of Wet- and Dry-Bulb Temperatures)⁸
 E 380 Practice for Use of International System of Units (SI)⁷
 E 691 Practice for Conducting an Interlaboratory Study to Determine the Precision of a Test Method⁷

3. Terminology

3.1 *Definitions*—The definitions of terms relating to shear strength testing appearing in Terminology E 6 apply to the terms used in this test method. The definitions of terms relating to advanced ceramics appearing in Terminology C 1145 apply to the terms used in this test method. The definitions of terms relating to fiber-reinforced composites appearing in Terminology D 3878 apply to the terms used in this test method. Additional terms used in conjunction with this test method are defined in the following.

3.1.1 *advanced ceramic*—an engineered high-performance predominately nonmetallic, inorganic, ceramic material having specific functional attributes.

3.1.2 *continuous fiber-reinforced ceramic matrix composite (CFCC)*—a ceramic matrix composite in which the reinforcing phase consists of a continuous fiber, continuous yarn, or a woven fabric.

3.1.3 *shear failure load*—the maximum load required to fracture a shear loaded test specimen.

3.1.4 *shear strength*—the maximum shear stress that a material is capable of sustaining. Shear strength is calculated from the shear fracture load and the shear loaded area.

4. Summary of Test Method

4.1 This test method addresses two methods to determine the shear strength of CFCCs: (1) the compression of a double-notched specimen test method to determine interlaminar shear strength⁹ and (2) the Iosipescu test method to determine the shear strength in any one of the material planes of laminated CFCCs.¹⁰

4.1.1 *Shear Test by Compression Loading of Double-Notched Specimens*—The interlaminar shear strength of CFCCs, as determined by this method is measured by loading in compression a double-notched specimen of uniform width. Failure of the specimen occurs by shear between two centrally located notches machined halfway through the thickness and spaced a fixed distance apart on opposing faces. Schematics of the test setup and the specimen are shown in Fig. 1 and Fig. 2.

4.1.2 *Shear Test By the Iosipescu Method*—The shear strength of one of the different material shear planes of laminated CFCCs may be determined by loading a coupon in the form of a rectangular flat strip with symmetric centrally located V-notches using a mechanical testing machine and a four-point asymmetric fixture. The loading can be idealized as asymmetric flexure by the shear and bending diagrams in Fig. 3. Failure of the specimen occurs by shear between the V-notches. Different specimen configurations are addressed for this test method. Schematics of the test setup and specimen are shown in Fig. 4 and Fig. 5. The determination of shear properties of polymer matrix composites by the Iosipescu method has been presented in Test Method D 5379.

5. Significance and Use

5.1 Continuous fiber-reinforced ceramic composites are candidate materials for structural applications requiring high degrees of wear and corrosion resistance, and damage tolerance at high temperatures.

5.2 Shear tests provide information on the strength and deformation of materials under shear stresses.

5.3 This test method may be used for material development, material comparison, quality assurance, characterization, and design data generation.

5.4 For quality control purposes, results derived from standardized shear test specimens may be considered indicative of the response of the material from which they were taken for given primary processing conditions and post-processing heat treatments.

6. Interferences

6.1 Test environment (vacuum, inert gas, ambient air, etc.) including moisture content (for example, relative humidity) may

² Annual Book of ASTM Standards, Vol 15.01.

³ Annual Book of ASTM Standards, Vol 08.01.

⁴ Annual Book of ASTM Standards, Vol 08.02.

⁵ Annual Book of ASTM Standards, Vol 15.03.

⁶ Annual Book of ASTM Standards, Vol 03.01.

⁷ Annual Book of ASTM Standards, Vol 14.02.

⁸ Annual Book of ASTM Standards, Vol 11.03.

⁹ Whitney, J., M., "Stress Analysis of the Double Notch Shear Specimen," Proceedings of the American Society for Composites, 4th Technical Conference, Blacksburg Virginia, Oct. 3–5, 1989, Technomic Publishing Co, pp. 325.

¹⁰ Iosipescu, N., "New Accurate Procedure for Shear Testing of Metals," *Journal of Materials*, 2, 3, Sept. 1967, pp. 537–566.

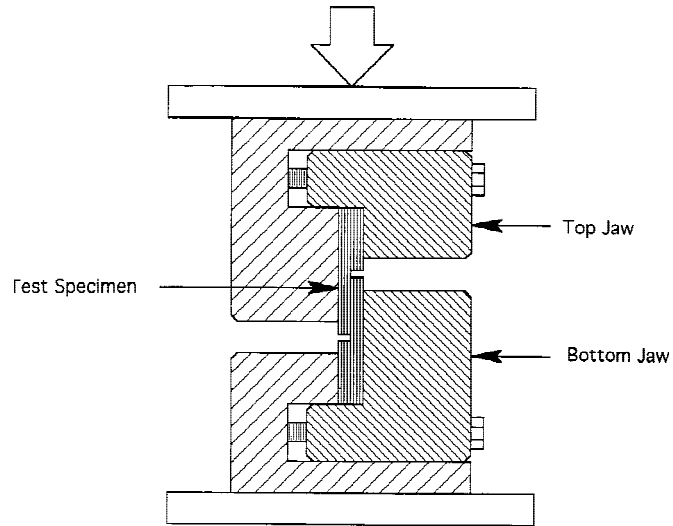
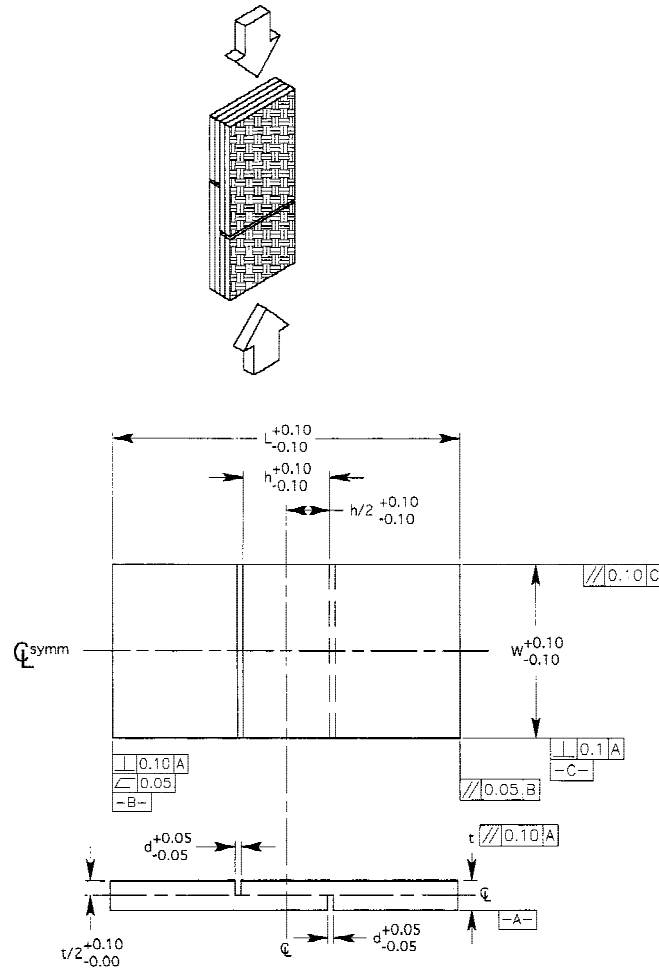

FIG. 1 Schematic of Test Fixture for the Double-Notched Compression Specimen



NOTE 1—All tolerances are in millimetres.

FIG. 2 Schematic of Double-Notched Compression Specimen

have an influence on the measured shear strength. In particular, the behavior of materials susceptible to slow crack growth fracture will be strongly influenced by test environment and testing rate. Testing to evaluate the maximum strength potential of a material shall be conducted in inert environments or at sufficiently rapid testing rates, or both, so as to minimize slow crack growth effects.

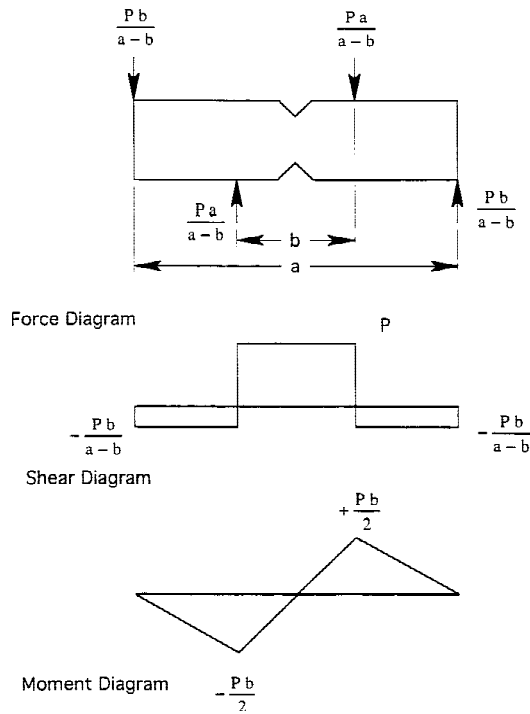

NOTE 1—The loads are depicted as being concentrated, whereas they are actually distributed over an area.

FIG. 3 Idealized Force, Shear, and Moment Diagrams for Asymmetric Four-Point Loading

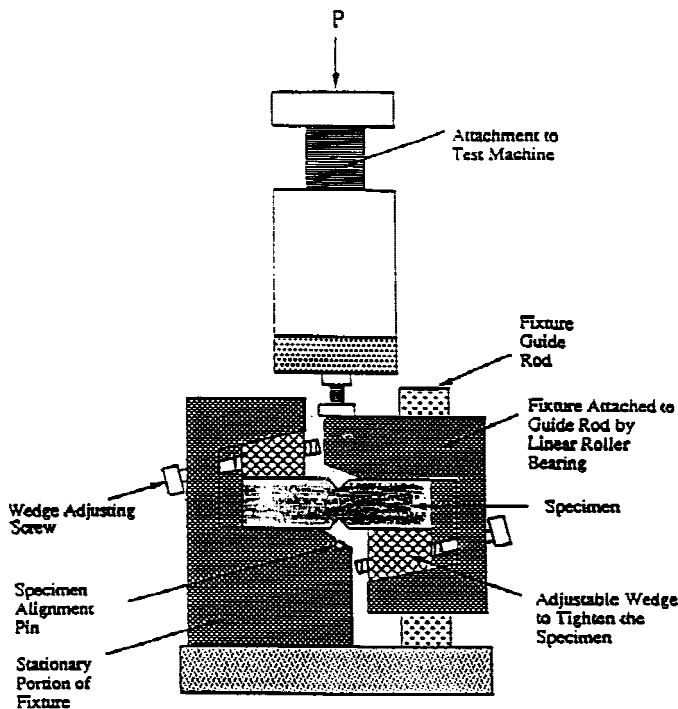
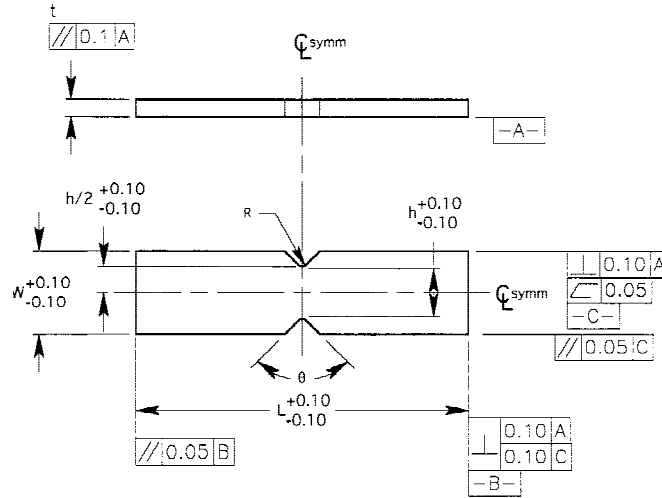
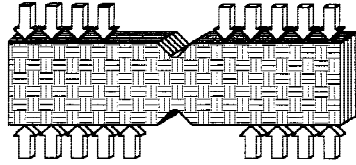

FIG. 4 Schematic of Test Fixture for the Iosipescu Test

Conversely, testing can be conducted in environments and testing modes and rates representative of service conditions to evaluate material performance under those conditions. When testing is conducted in uncontrolled ambient air with the intent of evaluating maximum strength potential, relative humidity and temperature must be monitored and reported. Testing at humidity levels >65 % RH is not recommended and any deviations from this recommendation must be reported.

6.2 Preparation of test specimens, although normally not considered a major concern with CFCCs, can introduce fabrication



NOTE 1—All tolerances are in millimetres.

FIG. 5 Schematic of the Iosipescu Specimen

flaws which may have pronounced effects on the mechanical properties and behavior (for example, shape and level of the resulting load-displacement curve and shear strength). Machining damage introduced during specimen preparation can be either a random interfering factor in the determination of shear strength of pristine material, or an inherent part of the strength characteristics to be measured. Universal or standardized test methods of surface preparation do not exist. Final machining steps may, or may not negate machining damage introduced during the initial machining. Thus, specimen fabrication history may play an important role in the measured strength distributions and shall be reported.

6.3 Bending in uniaxially loaded shear tests can cause or promote nonuniform stress distributions that may alter the desired uniform state of stress during the test.

6.4 Fractures that initiate outside the uniformly stressed gage section of a specimen may be due to factors such as localized stress concentrations, extraneous stresses introduced by improper loading configurations, or strength-limiting features in the microstructure of the specimen. Such non-gage section fractures will normally constitute invalid tests.

6.5 For the conduction of the Iosipescu test, thin test specimens (width to thickness ratio of more than ten) may suffer from splitting and instabilities rendering in turn invalid test results.

6.6 For the evaluation of the interlaminar shear strength by the compression of a double-notched specimen, the distance between the notches in the specimen has an effect on the maximum load and therefore on the shear strength. It has been found that the stress distribution in the specimen is independent of the distance between the notches when the notches are far apart. However, when the distance between the notches is such that the stress fields around the notches interact, the measured interlaminar shear strength increases. Because of the complexity of the stress field around each notch and its dependence on the properties and homogeneity of the material, it is recommended to conduct a series of tests on specimens with different spacing between the notches to determine their effect on the measured interlaminar shear strength.

6.7 For the evaluation of the interlaminar shear strength by the compression of a double-notched specimen, excessive clamping force with the jaws will reduce the stress concentration around the notches and therefore artificially increase the measured interlaminar shear strength. Because the purpose of the jaws is to maintain the specimen in place and to prevent buckling, avoid overtightening the jaws.

6.8 Most fixtures incorporate an alignment mechanism in the form of a guide rod and a linear roller bearing. Excessive free play or excessive friction in this mechanism may introduce spurious moments that will alter the ideal loading conditions.

7. Apparatus

7.1 *Testing Machines*—The testing machine shall be in conformance with Practices E 4. The loads used in determining shear strength shall be accurate within $\pm 1\%$ at any load within the selected load range of the testing machine as defined in Practices E 4.

7.2 *Data Acquisition*—At the minimum, autographic records of applied load and cross-head displacement versus time shall be obtained. Either analog chart recorders or digital data acquisition systems may be used for this purpose although a digital record is recommended for ease of later data analysis. Ideally, an analog chart recorder or plotter shall be used in conjunction with the digital data acquisition system to provide an immediate record of the test as a supplement to the digital record. Recording devices must be accurate to $\pm 1\%$ of full scale and shall have a minimum data acquisition rate of 10 Hz with a response of 50 Hz deemed more than sufficient.

7.3 *Dimension-Measuring Devices*—Micrometers and other devices used for measuring linear dimensions must be accurate and precise to at least 0.01 mm.

7.4 Test Fixtures:

7.4.1 *Double-notched Compression Specimen*—The fixture consists of a stationary element mounted on a base plate, an element that attaches to the crosshead of the testing machine, and two jaws to fix the specimen in position. A schematic description of the test fixture is shown in Fig. 1.¹¹ A supporting jig conforming to the geometry of that shown in Fig. 1 of Test Method D 3846 or Fig. 4 of Test Method D 695 may also be used.

7.4.2 *Iosipescu Specimen*—The fixture shall be a four-point asymmetric flexure fixture shown schematically in Fig. 4.¹¹ This fixture consists of a stationary element mounted on a base plate, and a movable element capable of vertical translation guided by a stiff post. The movable element attaches to the cross-head of the testing machine. Each element clamps half of the test specimen into position with a wedge action grip able to compensate for minor specimen width variations. A span of 13 mm is left unsupported between fixture halves. An alignment tool is recommended to ensure that the specimen notch is aligned with the line-of-action of the loading fixture.

8. Hazards

8.1 During the conduct of this test method, the possibility of flying fragments of broken test material may be high. The brittle nature of advanced ceramics and the release of strain energy contribute to the potential release of uncontrolled fragments upon fracture. Means for containment and retention of these fragments for later fractographic reconstruction and analysis is highly recommended.

8.2 Exposed fibers at the edges of CFCC specimens present a hazard due to the sharpness and brittleness of the ceramic fiber. All persons required to handle these materials shall be well informed of these conditions and the proper handling techniques.

9. Test Specimens

9.1 Test Specimen Geometry:

9.1.1 *Double-Notched Compression Specimen*—The test specimens shall conform to the shape and tolerances shown in Fig. 2. The specimen consists of a rectangular plate with notches machined on both sides. The depth of the notches shall be at least equal to one half of the specimen thickness, and the distance between the notches shall be determined considering the requirements to produce shear failure in the gage section. Furthermore, because the measured interlaminar shear strength may be dependent on the notch separation, it is recommended to conduct tests with different values of notch separation to determine this dependence. The edges of the specimens shall be smooth, but not rounded or beveled. Table 1 contains recommended values for the dimensions associated with the specimen shown in Fig. 2.

9.1.2 *The Iosipescu Specimen*—The required specimen shape and tolerances are shown in Fig. 5, while Table 2 contains recommended values for the specimen dimensions. If required, the specimen dimensions, particularly the notch angle, notch depth, and notch radius may be adjusted to meet special material requirements, but any deviation from the recommended values contained in Table 2 shall be reported with the test results, although the standard tolerances shown in Fig. 5 still apply. The shear strength

¹¹ This test method is under the jurisdiction of ASTM Committee C-28 on Advanced Ceramics and is the direct responsibility of Subcommittee C28.07 on Ceramic Matrix Composites.

Current edition approved April 10, 2000. Published July 2000. Originally published as C 1292 – 95. Last previous edition C 1292 – 95a.

TABLE 1 Recommended Dimensions for Double-Notched Compression Specimen

Dimension	Description	Value, mm
<i>L</i>	Specimen length	30.00
<i>h</i>	Distance between notches	6.00
<i>W</i>	Specimen width	15.00
<i>d</i>	Notch width	0.50
<i>t</i>	Specimen thickness	...

TABLE 2 Recommended Dimensions for Iosipescu Specimen

Dimension	Description	Value
<i>L</i>	Specimen length	76.00 mm
<i>h</i>	Distance between notches	11.00 mm
<i>W</i>	Specimen width	19.00 mm
<i>R</i>	Notch radius	1.30 mm
θ	Notch angle	90.0°
<i>t</i>	Specimen thickness	...

in any one of the principal shear planes of laminated CFCCs, may be obtained by orienting the testing plane of the specimen with the desired composite material plane as indicated in Fig. 6 for example. End-tabs, adhesively bonded to both faces of the specimen away from the test section, are recommended to avoid local crushing failure and specimen twisting in the fixture.

9.1.2.1 Due to limitations in material processing, in some instances it may be difficult to produce thick sections to conform with the dimensions and geometry shown in Table 2 and contained in Fig. 5 respectively, the specimen geometry may be modified in order to obtain appropriate results. This may be true if the interlaminar shear strength is sought by using the Iosipescu test for example. In this case, adhesively bonded end-tabs may be used, and the depth and angle of the notches must be selected to promote shear failure between the V-notches. Fig. 7 shows an example of this situation.

9.2 Specimen Preparation:

9.2.1 *Customary Practices*—In instances where a customary machining procedure has been developed that is completely satisfactory for a class of materials (that is, it induces no unwanted surface/subsurface damage or residual stresses), this procedure shall be used.

9.2.2 *Standard Procedures*—Studies to evaluate the machinability of CFCCs have not been completed. Therefore, the standard procedure of this section can be viewed as starting-point guidelines but a more stringent procedure may be necessary.

9.2.2.1 All grinding or cutting shall be done with ample supply of appropriate filtered coolant to keep the workplace and grinding wheel constantly flooded and particles flushed. Grinding can be done in at least two stages, ranging from coarse to fine rate of material removal.

9.2.2.2 Stock removal rate shall be on the order of 0.03 mm per pass using diamond tools that have between 320 and 600 grit. Remove equal stock from each face where applicable.

9.3 *Handling Precaution*—Exercise care in the storage and handling of finished specimens to avoid the introduction of random and severe flaws. In addition, direct attention to pre-test storage of specimens in controlled environments or desiccators to avoid

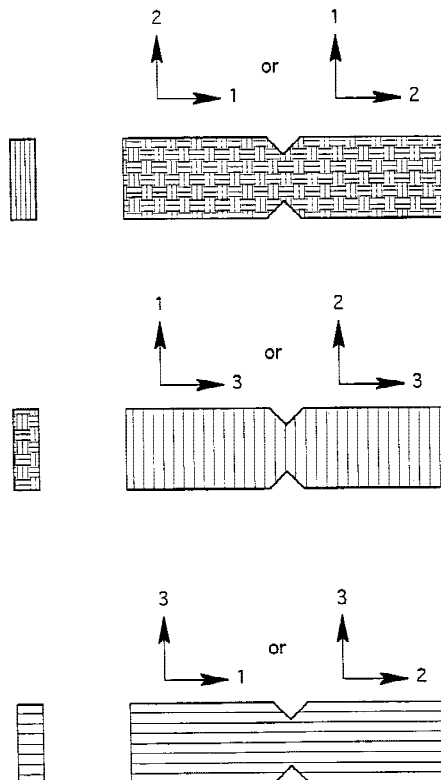

FIG. 6 Orientation of Material Planes to Obtain the Strength of Any One of the Three Shear Planes of Laminated Composites

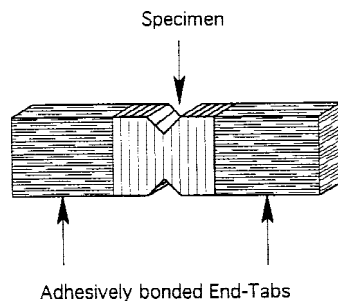

FIG. 7 Schematic Representation of Adhesively Bonded End-Tabs for Determining Interlaminar Shear Strength Using Thin Specimens

unquantifiable environmental degradation of specimens prior to testing.

9.4 *Number of Specimens*—A minimum of ten specimens per test condition shall be tested unless valid results can be gained through the use of fewer specimens, such as in the case of a designed experiment. For statistically significant data, the procedures outlined in Practice E 122 shall be consulted.

10. Procedure

10.1 *Specimen Dimensions*—Determine the thickness and width of the gage section of each specimen to within 0.02 mm. To avoid damage in the critical gage section area perform these measurements either optically (for example, an optical comparator) or mechanically, using a flat, anvil-type micrometer. In either case the resolution of the instrument shall be as specified in 7.3. Exercise extreme caution to prevent damage to the specimen gage section. Record and report the measured dimensions and locations of the measurements for use in the calculation of the shear stress. Use the average of multiple measurements in the stress calculations.

10.1.1 Additionally, make post-fracture measurements of the gage section dimensions using instruments described in 10.1. In the case of post-fracture measurements, measure and record only the dimensions at the plane of fracture for the purpose of calculating the shear strength. Note that in some cases, the fracture process can severely fragment the gage section thus making post-fracture measurements of dimensions difficult. In these cases the procedures outlined in 10.1 shall suffice.

10.2 Test Modes and Rates:

10.2.1 *General*—Test modes may involve load or displacement control. Recommended rates of testing shall be sufficiently rapid to obtain the maximum possible shear strength at fracture of the material within 30 s. However, rates other than those recommended here may be used to evaluate rate effects. In all cases, report the test mode and rate.

10.2.1.1 Generally, displacement controlled tests are employed in such cumulative damage or yielding deformation processes to prevent a run away condition (that is, rapid uncontrolled deformation and fracture) characteristic of load or stress controlled tests. However, for sufficiently rapid test rates, differences in the fracture process may not be noticeable and any of these test modes may be appropriate.

10.2.2 *Displacement Rate*—Use a constant cross-head displacement rate of 0.05 mm/s unless otherwise found acceptable as determined under conditions 10.2.1 or 10.2.1.1.

10.2.3 *Load Rate*—Select a constant loading rate to produce final fracture in 10 to 30 s or to be approximately equivalent to a test rate of 0.05 mm/s.

10.3 *Preparations for Testing*—Set the test mode and test rate on the test machine. Ready the autograph data acquisition systems for data logging.

10.4 Conducting the Test:

10.4.1 Mount the specimen in the test fixture.

10.4.1.1 *Double-Notched Compression Specimen*—Loosen the jaw of each grip sufficiently to allow the specimen thickness to be freely inserted into the fixture with clearance. Place the specimen loosely in the center of the fixture and then press the back side of the specimen against the back wall of the fixture while aligning the bottom of the specimen against the bottom of the fixture. Center the specimen in the fixture so that the line-of-action of the load acts directly through the mid-plane of the coupon. Lightly tighten the jaws to fix the specimen in the fixture. *Do not overtighten the jaws.* The purposes of the jaws are to maintain the specimen in place and to prevent buckling, not for clamping. Overtightening the jaws will result in artificially high shear strengths.¹² Slowly move the cross-head of the testing machine until the upper surface of the fixture just contacts the upper surface of the specimen.

10.4.1.2 *Iosipescu Specimen*—Loosen the jaw of each grip sufficiently to allow the specimen width to be freely inserted into the grip with clearance. Adjust the movable head position until the grips are approximately aligned vertically. Place the alignment

¹² Fang, N. J., and Chou, T. W., "Characterization of Interlaminar Shear Strength of Ceramic Matrix Composites," *Journal of American Ceramic Society*, 76, 10 2539-48, 1993.

tool in the groove in the lower fixture grip. Place the specimen loosely into both grips. Press the back side of the specimen flat against the back wall of the fixture. Pull the specimen alignment tool vertically up into the notch to center the specimen V-notch relative to the fixture in accordance with Fig. 8. While keeping the specimen centered, lightly tighten the left-hand side jaw on the lower grip. *Do not overtighten the jaw*; overtightening induces undesirable pre-loading and may damage some materials. There now should be some clearance between the specimen and the upper grip and no load showing in the test machine. If there is no clearance, or if load in the specimen is indicated, adjust either the head or the jaw of the upper grip, or both, until there is both clearance and zero load. Recheck the specimen placement in the lower grip. Repeat if necessary. Move the testing machine cross-head until the upper surface of the upper grip just contacts the upper surface of the right-hand side of the specimen, without loading it. Lightly tighten the jaw of the upper right-hand grip onto the right-hand side of the specimen. *Do not overtighten the jaw*; overtightening induces undesirable pre-loading and may damage some materials. Pre-load should be minimized, however, a small amount of pre-load (20 to 50 N) may be unavoidable. The specimen should now be centered in the fixture so that the line-of-action of the load acts directly through the center of the notch on the specimen.

10.4.2 Begin data acquisition. Initiate the action of the test machine.

10.4.3 After specimen fracture, disable the action of the test machine and the data collection of the data acquisition system. Measure the breaking load with an accuracy of $\pm 1\%$ of the load range and note for the report. Carefully remove the specimen halves from the specimen mount and determine the dimensions of the failed sheared area to the nearest 0.02 mm by measurement of this surface with respect to either half of the ruptured specimen. This technique affords the most accurate determination of the length of the sheared plane defined by the separation of the notches machined in the specimen. Avoid damaging the fracture surfaces by preventing them from contacting each other or other objects.

10.4.4 Determine the ambient temperature and relative humidity in accordance with Test Method E 337.

10.4.5 Note that use of results from specimens fracturing outside the uniformly stressed gage section cannot be used in the direct calculation of a mean shear strength. Results from specimens fracturing outside the gage section are considered anomalous and can be used only as censored tests. To complete a required statistical sample for purposes of average strength, test one replacement specimen for each specimen that fractures outside the gage section.

10.4.6 Visual examination and light microscopy are recommended to determine the mode and type of fracture, as well as the location of fracture initiation.

11. Calculation of Results

11.1 Shear Strength:

11.1.1 *Double-Notched Compression Specimen*—Calculate the shear strength as follows:

$$\text{Shear Strength} = \frac{P_{\max}}{A} \tag{1}$$

where P_{\max} is the applied maximum load and A is the shear stressed area, which is calculated as follows:

$$A = Wh \tag{2}$$

where W is the average specimen width and h is the distance between the notches (see Fig. 2).

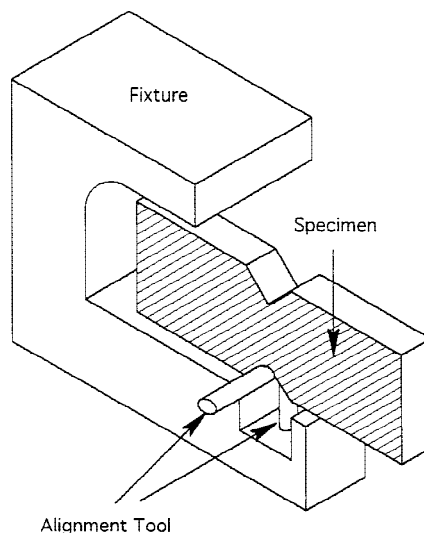

NOTE 1—Remainder of fixture not shown for clarity.

FIG. 8 Specimen Placement in Fixture

11.1.2 *The Iosipescu Specimen*—Calculate the shear strength as follows:

$$\text{Shear Strength} = \frac{P_{\max}}{A} \quad (3)$$

where P_{\max} is the applied maximum load and A is the shear stressed area, which is calculated as follows:

$$A = t h \quad (4)$$

where t is the average specimen thickness and h is the distance between the V-notches (Fig. 5).

11.2 Statistics—For each series of tests, calculate the average value, standard deviation and coefficient of variation (in percent) for each property determined:

$$\bar{x} = \frac{1}{n} \left(\sum_{i=1}^n x_i \right) \quad (5)$$

$$s_{n-1} = \sqrt{\left(\sum_{i=1}^n x_i^2 - n \bar{x}^2 \right) / (n - 1)} \quad (6)$$

$$CV = 100 \times s_{n-1} / \bar{x} \quad (7)$$

where:

- \bar{x} = sample mean (average),
- s_{n-1} = sample standard deviation,
- CV = sample coefficient of variation, %,
- n = number of specimens, and
- x_i = measured or derived property.

12. Report

12.1 *Test Set*—Report the following information for the test set. Any significant deviations from the procedures and requirements of these test methods shall be noted in the report.

12.1.1 Date and location of testing.

12.1.2 Test specimen geometry used (including engineering drawing).

12.1.3 Include a drawing or sketch of the type and configuration of the test machine. If a commercial test machine is used, the manufacturer and model number of the test machine will suffice.

12.1.4 Indicate what test method (compression of a double-notched specimen or the Iosipescu test) was used. Include a drawing or sketch of the type and configuration of the specimen mount.

12.1.5 Include the total number of specimens (n) with special emphasis on the number of specimens that fractured in the gage section. This information will reveal the success rate of the particular specimen geometry and test apparatus.

12.1.6 Include all relevant data such as vintage and identification data, with emphasis on the date of manufacture of the material and a short description of reinforcement (type, layup, etc.), fiber volume fraction, and bulk density. For commercial materials, the commercial designation shall be reported.

12.1.6.1 For noncommercial materials, the major constituents and proportions shall be reported as well as the primary processing route including green state and consolidation routes. Also report fiber volume fraction, matrix porosity, and bulk density.

12.1.7 Description of the method of specimen preparation including all stages of machining.

12.1.8 Heat treatments, coatings, or pretest exposures, if any, applied either to the as-processed material or to the as-fabricated specimen.

12.1.9 Test environment including relative humidity (Test Method E 337), ambient temperature, and atmosphere (for example, ambient air, dry nitrogen, silicone oil, etc.).

12.1.10 Test mode (load or displacement control) and actual test rate (load rate or displacement rate).

12.1.11 Mean, standard deviation, and coefficient of variation for the measured shear strength for each test series.

12.1.12 Appearance of specimen after fracture.

13. Precision and Bias

13.1 The shear strength of continuous fiber-reinforced ceramic matrix composites is not deterministic, but will vary from one test specimen to another. Variations in composite properties result from inherent variations in the nature properties of these materials the constituents, and from variations in fiber architecture, fiber volume fraction, density, and uniformity in fiber coating thickness. Such variations can occur spatially within a given test specimen, as well as between different test specimens.

13.2 A multiple laboratory round-robin test program¹³ was conducted in 1998 to determine the precision and bias of shear strength of continuous fiber-reinforced ceramic matrix composite in accordance with Test Method C 1292 for a commercially available material.¹⁴ The repeatability and reproducibility were assessed for the in-plane shear strength and interlaminar shear strength based on a variety of the results from the evaluation of applicable CFCCs; ten specimens by eight laboratories for the in-plane shear strength and by seven laboratories for the interlaminar shear strength. Bias was not evaluated because there is no commonly recognized standard reference material for continuous fiber-reinforced ceramic matrix composites.

13.3 In-Plane Shear Strength:

13.3.1 In-plane shear specimens were 76 mm long, 19 mm wide, and had a nominal thickness of 3 mm. The nominal separation between the V-notches was 11 mm. The specimens were diamond-grit cut from three panels of a commercial Sylramic™ S200 ceramic composite. The panels were fabricated with eight plies of ceramic grade Nicalon™ fabric (8-harness satin weave) coated with boron nitride and embedded in a polymer-derived silicon-carbonitride matrix. The material had a nominal fiber volume fraction of 45 %, a mean bulk density of 2.21 g/cm³, and average open porosity of 2.7 %.

13.3.2 Round-robin participants were required to perform in-plane shear strength tests in accordance with Test Method C 1292. Tests were conducted in ambient conditions at a constant cross-head displacement rate of 0.05 mm/s.

13.3.3 A statistical analysis of the in-plane shear strength test results was performed using the procedures and criteria of Practice E 691. All the results for in-plane shear strength were determined to be valid and applicable. Repeatability and reproducibility are contained in Table 3.

13.4 Interlaminar Shear Strength:

13.4.1 Interlaminar shear specimens were 30 mm long, 15 mm wide, and had a nominal thickness of 3 mm. The nominal notch separation was 6 mm. The specimens were diamond-grit cut from three panels of a commercial Sylramic™ S200 ceramic composite. The notches were machined in several passes and had a nominal width of 0.05 mm and a nominal depth of 1.5 mm. The panels were fabricated with eight plies of ceramic grade Nicalon™ fabric (8-harness satin weave) coated with boron nitride and embedded in a polymer-derived silicon-carbonitride matrix. The material had a nominal fiber volume fraction of 45 %, a mean bulk density of 2.21 g/cm³, and average open porosity of 2.7 %.

13.4.2 Round-robin participants were required to perform interlaminar shear strength tests in accordance with Test Method C 1292. Tests were conducted at a constant cross-head displacement rate of 0.05 mm/s.

13.4.3 A statistical analysis of the interlaminar shear strength test results was performed using the procedures and criteria of Practice E 691. All the results for interlaminar shear strength were determined to be valid and applicable. Repeatability and reproducibility are contained in Table 4 in accordance with Practice E 177.

13.5 Sources of Variability—The test results were analyzed for variability in experimental procedures between laboratories and for variability in materials thickness, density, and porosity among the test specimens, as well as differences between test specimens cut from the three different panels. Possible statistically significant effects were indicated for location and size of the notches with respect to the mesostructure of the material.

14. Keywords

14.1 composite; compression; continuous fiber-reinforced ceramic composite (CFCC); in-plane; interlaminar; Iosipescu; shear; shear strength

¹³ Lara-Curzio, Edgar, Jenkins, M. G., and Gonczy, S., “Results of Round-Robin Testing Program to Determine Precision and Bias of ASTM C 1292 Standard Test Methods for Shear Strength of CFCC,” Presented at 23rd Annual Cocoa Beach Meeting and Exposition, Cocoa Beach, FL, Jan. 25-29, 1999.

¹⁴ Dow Corning Inc., Midland, MI, November 1997. As of July 1999, manufactured by Engineered Ceramics, Inc., San Diego, CA.

**TABLE 3 In-Plane Shear Strength Data and Repeatability/
Reproducibility Analysis**

Mean value for the 8 laboratories	110.79 MPa	
Standard deviation of the averages of the 8 laboratories	4.96 MPa	4.48 %
Repeatability standard deviation	2.26 MPa	2.04 %
Reproducibility standard deviation	5.39 MPa	4.88 %
95 % repeatability limit	6.33 MPa	5.71 %
95 % reproducibility limit	15.15 MPa	13.67 %

**TABLE 4 Interlaminar Shear Strength Data and Repeatability/
Reproducibility Analysis**

Mean value for the 7 laboratories	33.0 MPa	
Standard deviation of the averages of the 7 laboratories	5.35 MPa	16.2 %
Repeatability standard deviation	2.52 MPa	7.6 %
Reproducibility standard deviation	5.83 MPa	17.7 %
95 % repeatability limit	7.06 MPa	21.4 %
95 % reproducibility limit	16.32 MPa	49.5 %

ASTM International takes no position respecting the validity of any patent rights asserted in connection with any item mentioned in this standard. Users of this standard are expressly advised that determination of the validity of any such patent rights, and the risk of infringement of such rights, are entirely their own responsibility.

This standard is subject to revision at any time by the responsible technical committee and must be reviewed every five years and if not revised, either reapproved or withdrawn. Your comments are invited either for revision of this standard or for additional standards and should be addressed to ASTM International Headquarters. Your comments will receive careful consideration at a meeting of the responsible technical committee, which you may attend. If you feel that your comments have not received a fair hearing you should make your views known to the ASTM Committee on Standards, at the address shown below.

This standard is copyrighted by ASTM International, 100 Barr Harbor Drive, PO Box C700, West Conshohocken, PA 19428-2959, United States. Individual reprints (single or multiple copies) of this standard may be obtained by contacting ASTM at the above address or at 610-832-9585 (phone), 610-832-9555 (fax), or service@astm.org (e-mail); or through the ASTM website (www.astm.org).