



Designation: C 1326 – 99

Standard Test Method for Knoop Indentation Hardness of Advanced Ceramics¹

This standard is issued under the fixed designation C 1326; the number immediately following the designation indicates the year of original adoption or, in the case of revision, the year of last revision. A number in parentheses indicates the year of last reapproval. A superscript epsilon (ϵ) indicates an editorial change since the last revision or reapproval.

1. Scope

1.1 This test method covers the determination of the Knoop indentation hardness of advanced ceramics.

1.2 *This standard does not purport to address all of the safety concerns, if any, associated with its use. It is the responsibility of the user of this standard to establish appropriate safety and health practices and determine the applicability of regulatory limitations prior to use.*

2. Referenced Documents

2.1 ASTM Standards:

C 730 Test Method for Knoop Indentation Hardness of Glass²

C 849 Test Method for Knoop Indentation Hardness of Ceramic Whitewares²

E 4 Practices for Force Verification of Testing Machines³

E 177 Practice for Use of the Terms Precision and Bias in ASTM Test Methods⁴

E 380 Practice for Use of the International System of Units (SI) (the Modernized Metric System)⁴

E 384 Test Method for Microhardness of Materials³

E 691 Practice for Conducting an Interlaboratory Study to Determine the Precision of a Test Method⁴

2.2 European Standard:

CEN ENV 843-4 Advanced Technical Ceramics, Monolithic Ceramics, Mechanical Properties at Room Temperature, Part 4: Vickers, Knoop, and Rockwell Superficial Hardness Tests⁵

2.3 ISO Standard:

ISO 9385 Glass and Glass Ceramics—Knoop Hardness Test⁶

3. Terminology

3.1 Definition:

¹ This test method is under the jurisdiction of ASTM Committee C-28 on Advanced Ceramics and is the direct responsibility of Subcommittee C28.01 on Properties and Performance.

Current edition approved Jan. 10, 1999. Published April 1999. Originally published as C 1326 – 96. Last previous edition C 1326 – 96a.

² *Annual Book of ASTM Standards*, Vol 15.02.

³ *Annual Book of ASTM Standards*, Vol 03.01.

⁴ *Annual Book of ASTM Standards*, Vol 14.02.

⁵ Available from European Committee for Standardization, Brussels, Belgium.

⁶ Available from International Standards Organization, Geneva, Switzerland.

3.1.1 *Knoop hardness number (HK), n*—an expression of hardness obtained by dividing the force applied to the Knoop indenter by the projected area of the permanent impression made by the indenter.

3.1.2 *Knoop indenter, n*—a rhombic-based pyramidal-shaped diamond indenter with edge angles of 172° 30' and 130° 00'.

4. Summary of Test Method

4.1 This test method describes an indentation hardness test using a calibrated machine to force a pointed, rhombic base, pyramidal diamond indenter having specified face angles, under a predetermined load, into the surface of the material under test and measures the surface projection of the long diagonal of the resulting impression after removal of the load.

NOTE 1—A general description of the Knoop indentation hardness test is given in Test Method E 384. The present test method differs from this description only in areas required by the special nature of advanced ceramics.

NOTE 2—This test method is similar to Test Methods C 730 and C 849, but differs primarily in the choice of load and the rate of loading. In addition, the length correction factor for the resolution limits of optical microscopes is not utilized.

5. Significance and Use

5.1 For advanced ceramics, Knoop indenters are used to create indentations. The surface projection of the long diagonal is measured with optical microscopes.

5.2 The Knoop indentation hardness is one of many properties that is used to characterize advanced ceramics. Attempts have been made to relate Knoop indentation hardness to other hardness scales, but no generally accepted methods are available. Such conversions are limited in scope and should be used with caution, except for special cases where a reliable basis for the conversion has been obtained by comparison tests.

5.3 For advanced ceramics, the Knoop indentation is often preferred to the Vickers indentation since the Knoop long diagonal length is 2.8 times longer than the Vickers diagonal for the same load, and cracking is much less of a problem (1).⁷ On the other hand, the long slender tip of the Knoop indentation is more difficult to precisely discern, especially in materials with low contrast. The indentation loads chosen in this test

⁷ The boldface numbers in parentheses refer to the list of references at the end of this test method.

method are designed to produce indentations as large as may be possible with conventional microhardness equipment, yet not so large as to cause cracking.

5.4 The Knoop indentation is shallower than Vickers indentations made at the same load. Knoop indents may be useful in evaluating coating hardnesses.

5.5 Knoop hardness is calculated from the ratio of the applied load divided by the projected indentation area on the specimen surface. It is assumed that the elastic springback of the narrow diagonal is negligible. (Vickers indenters are also used to measure hardness, but Vickers hardness is calculated from the ratio of applied load to the area of contact of the four faces of the undeformed indenter.)

5.6 A full hardness characterization includes measurements over a broad range of indentation loads. A comprehensive characterization of this type is recommended but is beyond the scope of this test method which measures hardness at a single, designated load.

6. Interferences

6.1 Cracking from the indentation tips can interfere with interpretation of the exact tip location. The loads chosen for this test method are sufficiently low that tip cracking, if it occurs, will cause tiny, rather tight cracks at the indentation tips in advanced ceramics. Such cracks will have a negligible interference on measurements of the long diagonal length (2) (unlike Vickers indentations in ceramics).

6.2 Cracking or spalling from the sides of the Knoop impression may also occur, possibly in a time-dependent manner (minutes or hours) after the impression is made. Small amounts of such lateral cracking have little or no influence upon measured hardness, provided that the tip impressions are still readable and the tips are not dislodged (2).

6.3 Porosity (either on or just below the surface) may interfere with measuring Knoop hardness, especially if the indentation falls directly onto a large pore or if the indentation tip falls in a pore.

6.4 At higher magnifications in the optical microscope, it may be difficult to obtain a sharp contrast between the indentation tip and the polished surface of some advanced ceramics. This may be overcome by careful adjustment of the lighting as discussed in Test Method E 384 and Refs (2, 3).

7. Apparatus

7.1 Testing Machines:

7.1.1 There are two general types of machines available for making this test. One type is a self-contained unit built for this purpose, and the other type is an accessory available for existing microscopes. Usually, this second type is fitted on an inverted-stage microscope. Descriptions of the various machines are available (4–6).

7.1.2 Design of the machine should be such that the loading rate, dwell time, and applied load can be set within the limits set forth in 10.5. It is an advantage to eliminate the human element whenever possible by appropriate machine design. The machine should be designed so that vibrations induced at the beginning of a test will be damped out by the time the indenter touches the sample.

7.1.3 The calibration of the balance beam should be checked monthly or as needed. Indentations in standard reference materials may also be used to check calibration when needed.

7.2 Indenter:

7.2.1 The indenter shall meet the specifications for Knoop indenters. See Test Method E 384.

7.2.2 Fig. 1 shows the indenter and its maximum usable dimensions. The diagonals have an approximate ratio of 7:1, and the depth of the indentation is approximately 1/30 the length of the long diagonal. A perfect Knoop indenter has the following angles:

7.2.2.1 Included longitudinal angle $172^{\circ} 30' 00''$ s.

7.2.2.2 Included transverse angle $130^{\circ} 00' 00''$ s.

7.2.3 The constant C_p (defined in 12.2) for a perfect indenter is 0.07028. The specifications require a variation of not more than 1 % from this value.

7.2.4 The offset at the indenter tip shall not exceed $1.0 \mu\text{m}$. See Test Method E 384.

7.2.5 The four faces of the indenter shall meet at sharp edges.

7.2.6 The diamond should be examined periodically, and if it is loose in the mounting material, chipped, or cracked, it shall be replaced.

NOTE 3—This requirement is from Test Method E 384 and is especially pertinent to diamond indenters that are used to measure hardness of ceramics. In addition, these indenters sometimes are used to precrack advanced ceramic specimens at loads higher than customarily used for hardness testing. Such usage can lead to indenter damage. The diamond indenter can be examined with a scanning electron microscope, or indents can be made into soft copper to help determine if a chip or crack is present. Indenters may also be inspected with an optical microscope with at least 500X power, but care should be taken to avoid damaging the microscope lens.

7.3 Measuring Microscope:

7.3.1 The measurement system shall be constructed so that the length of the diagonals can be determined with errors not exceeding $\pm 0.0005 \text{ mm}$.

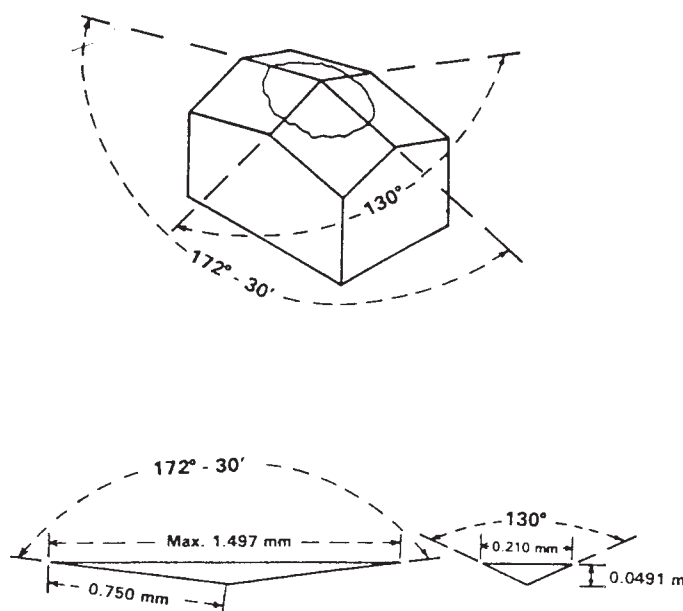

FIG. 1 Knoop Indenter Showing Maximum Usable Dimensions

NOTE 4—Stage micrometers with uncertainties less than this shall be used to establish calibration constants for the microscope. See Test Method E 384. Ordinary stage micrometers which are used for determining the approximate magnification of photographs may be ruled too coarse or may not have the required accuracy and precision.

7.3.2 The numerical aperture (NA) of the objective lens shall be between 0.65 and 0.90.

NOTE 5—The apparent length of a Knoop indentation will increase as the resolving power and NA of a lens increases. The range of NA specified by this test method corresponds to 40 to 100× objective lenses. The higher power lenses may have higher resolution, but the contrast between the indentation tips and the polished surface may be less.

7.3.3 A filter may be used to provide monochromatic illumination. Green filters have proved to be useful.

8. Test Specimens

8.1 The Knoop indentation hardness test is adaptable to a wide variety of advanced ceramic specimens. In general, the accuracy of the test will depend on the smoothness of the surface and, whenever possible, ground and polished specimens should be used. The back of the specimen shall be fixed so that the specimen cannot rock or shift during the test.

8.1.1 *Thickness*—As long as the specimen is over ten times as thick as the indentation depth, the test will not be affected. In general, if specimens are at least 0.50 mm thick, the hardness will not be affected by variations in the thickness.

8.1.2 *Surface Finish*—Specimens should have a ground and polished surface. The roughness should be less than 0.1 μm rms. However, if one is investigating a surface coating or treatment, one cannot grind and polish the specimen.

NOTE 6—This requirement is necessary to ensure that the surface is flat and that the indentation is sharp. Residual stresses from polishing are of less concern for most advanced ceramics than for glasses or metals. References (2) and (7) report that Knoop hardness was insensitive to surface finish for surfaces prepared with 1 μm or finer diamond abrasive. Hardness was only affected when the surface finish had an optically resolvable amount of abrasive damage (7). (Extra caution may be appropriate during polishing of transformation toughening ceramics, such as some zirconias, since the effect upon hardness is not known.)

8.1.3 *Radius of Curvature*—Care should be used when relating hardness values obtained on curved surfaces to those obtained on polished, flat surfaces. The hardness values obtained will be affected even when the curvature is only in the direction of the short diagonal.

9. Preparation of Apparatus

9.1 *Verification of Load*—Most of the machines available for Knoop hardness testing use a loaded beam. This beam shall be tested for zero load. An indentation should not be visible with zero load, but the indenter should contact the sample. Methods of verifying the load application are given in Practices E 4.

9.2 *Separate Verification of Load, Indenter, and Measuring Microscope*—Procedures in Test Method E 384, Section 14, may be followed.

9.3 *Verification by Standard Reference Materials*—Standard reference blocks, SRM No. 2830, of silicon nitride that are available from the National Institute of Standards and

Technology⁸ can be used to verify that an apparatus produces a Knoop hardness within ± 5 % of the certified value.

10. Procedure

10.1 *Specimen Placement*—Place the specimen on the stage of the machine so the specimen will not rock or shift during the measurement. The specimen shall be clean and free of any grease or film.

10.2 *Specimen Leveling*:

10.2.1 The surface of the specimen being tested shall lie in a plane normal to the axis of the indenter.

10.2.2 If one leg (one half) of the long diagonal is more than 10 % longer than the other, or if the ends of the diagonal are not both in the field of focus, the surface of the specimen may not be normal to the axis of the indenter. Align the specimen surface properly, and make another indentation.

NOTE 7—This tolerance is more stringent than the 20 % that is specified in Test Method E 384, but is less stringent than requirements in Test Methods C 730 and C 849.

10.2.3 Leveling the specimen to meet these specifications is facilitated if one has a leveling device.⁹

10.3 *Magnitude of Test Load*—A test load of either 9.81 N (1 kgf) or 19.61 N (2 kgf) is specified. 19.61 N is preferred. 9.81 N may be used if the higher load is not available on the apparatus, if cracking is a problem, or if preferred for a specific requirement. If cracking is a problem at 9.81 N, lower loads may be used and the reporting procedure of 12.6 shall be used. (The precision might be less and the bias greater with the lower loads.)

10.4 *Clean the Indenter*—The indenter shall be cleaned prior to and during a test series. A cotton swab with ethanol, methanol, or isopropanol may be used. Indenting into soft copper also may help remove debris.

NOTE 8—Ceramic powders or fragments from the ceramic test piece can adhere to the diamond indenter.

10.5 *Application of Test Load*:

10.5.1 Start the machine smoothly. The rate of indenter motion prior to contact with the specimen shall be 0.015 to 0.070 mm/s. If the machine is loaded by an electrical system or a dash-pot lever system, it should be mounted on shock absorbers which damp out all vibrations by the time the indenter touches the specimen.

NOTE 9—This rate of loading is consistent with Test Method E 384, but is faster than that prescribed in Test Methods C 730 and C 849.

10.5.2 The time of application of the full test load shall be 15 s (±2) unless otherwise specified. After the indenter has been in contact with the specimen for this required dwell time, raise it carefully off the sample to avoid a vibration impact.

⁸ National Institute of Standards and Technology, Standard Reference Materials Program, Gaithersburg, MD 20899.

⁹ The sole source of supply of the apparatus known to the committee at this time is the Tukon Tester leveling device, Catalog No. 85248, available from the Wilson Division of Instron Corp. If you are aware of alternative suppliers, please provide this information to ASTM Headquarters. Your comments will receive careful consideration at a meeting of the responsible technical committee,¹ which you may attend.

10.5.3 The operator shall not bump or inadvertently contact the test machine or the associated support (for example, the table) during the period of indenter contact with the specimen.

10.6 *Spacing of Indentations*—Allow a distance of at least one and a half indentation times the long diagonal between the indentations as illustrated in Fig. 2. If there is evidence of interaction between lateral cracking (from the sides of the indentation), then the spacing shall be increased.

10.7 *Acceptability of Indentations*— If there is excessive cracking from the indent sides, the indent shall be rejected for measurement. Fig. 3 provides guidance in this assessment. If this occurs on most indentations, a lower indentation load shall be used. If one or both tips of an indentation fall in a pore, the indentation shall be rejected. If the indentation lies in or on a large pore, the indent shall be rejected. If the impression has an irregularity that indicates the indenter is chipped or cracked, the indent shall be rejected and the indenter shall be replaced.

NOTE 10—In many ceramics, porosity may be small and finely distributed. The indentations will intersect some porosity. The measured hardness in such instances properly reflects a diminished hardness relative to the fully dense advanced ceramic. The intent of the restrictions in 10.7 is to rule out obviously unsatisfactory or atypical indentations for measurement purposes.

10.8 *Location of Indentations*—Indentations shall be made in representative areas of the advanced ceramic microstructure. They shall not be restricted to high-density regions if such exist.

10.9 *Number of Indentations*—For homogeneous and fully dense advanced ceramics, at least five and preferably ten acceptable indentations shall be made. If the ceramic is multiphase, not homogeneous, or not fully dense, ten acceptable indentations shall be made.

11. Measurement of Indentation

11.1 The accuracy of this test method depends to a very large extent on this measurement, as follows:

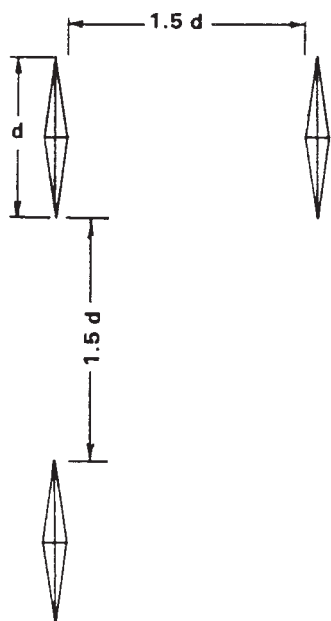

FIG. 2 Closest Permitted Spacing for Knoop Indentations

11.1.1 If the measuring system contains a light source, take care to use the system only after it has reached equilibrium temperature. This is because the magnification of a microscope depends on the tube length.

11.1.2 Calibrate the measuring system carefully with a stage micrometer or an optical grating.

11.1.3 Adjust the illumination and focusing conditions carefully as specified in Test Method E 384 to obtain the optimum view and clarity of the impression. Proper focus and illumination are critical for accurate and precise readings. Both indentation tips shall be in focus at the same time. Do not change the focus once the measurement of the diagonal length has begun.

NOTE 11—The lighting intensity and the settings of the field and aperture diaphragms can have a pronounced effect upon the apparent tip locations in Knoop indentations. Consult the manufacturer's guidelines for optimum procedures. Additional information is presented in Test Method E 384 and Ref (2). In general, the field diaphragm can be closed so that it barely enters or just disappears from the field of view. The aperture diaphragm can be closed in order to reduce glare and sharpen the image, but it should not be closed so much as to cause diffraction that distorts the edges of the indentation.

11.1.4 If either a measuring microscope or a filar micrometer eyepiece is used, always rotate the drum in the same direction to eliminate backlash errors.

11.1.5 Follow the manufacturer's guidelines for the use of crosshairs or graduated lines. To eliminate the influence of the thickness of the line(s), always use the same edge of the crosshair or graduation line. **Caution**—Serious systematic errors can occur due to improper crosshair usage. Procedures vary considerably between different equipment. In nearly all instances, the crosshairs should not be placed entirely over or fully cover the indentation tip as shown in Fig. 4a. The indentation tip should be just visible in the fringe of light on the side of the crosshair or graduated line as shown in Fig. 4b or Fig. 4c. In some measuring systems with twin crosshairs, the measurement is made with the inside edge of the two lines as shown in Fig. 4b. In other measuring systems, particularly those with a single moveable crosshair, the measurement is made with the same side of the crosshair as shown in Fig. 4c.

11.1.6 Read the indentation long diagonal length to the nearest 0.0005 mm or less. Check each reading twice. They should reproduce to 0.0005 mm.

11.1.7 Use the same filters in the light system at all times. Usually a green filter is used.

11.1.8 For transparent or translucent ceramics, where contrast is poor, the specimen may be coated (for example, a gold/palladium coating) to improve the measurability of the indents (8). Such coatings shall be less than 50 nm thick and shall be applied after the indentations have been made. Do not indent into coatings made to enhance visibility.

12. Calculation

12.1 Knoop hardness may be calculated and reported either in units of GPa (12.2) or as a Knoop hardness number (12.3).

12.2 The Knoop hardness reported with units of GPa is computed as follows:

$$HK = 1.000 \times 10^{-3} (P/A_p) \\ = 1.000 \times 10^{-3} (P/d^2 C_p)$$

ACCEPTABLE INDENTATIONS

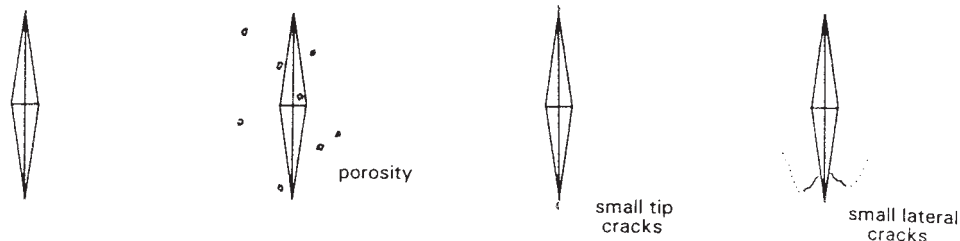

UNACCEPTABLE INDENTATIONS

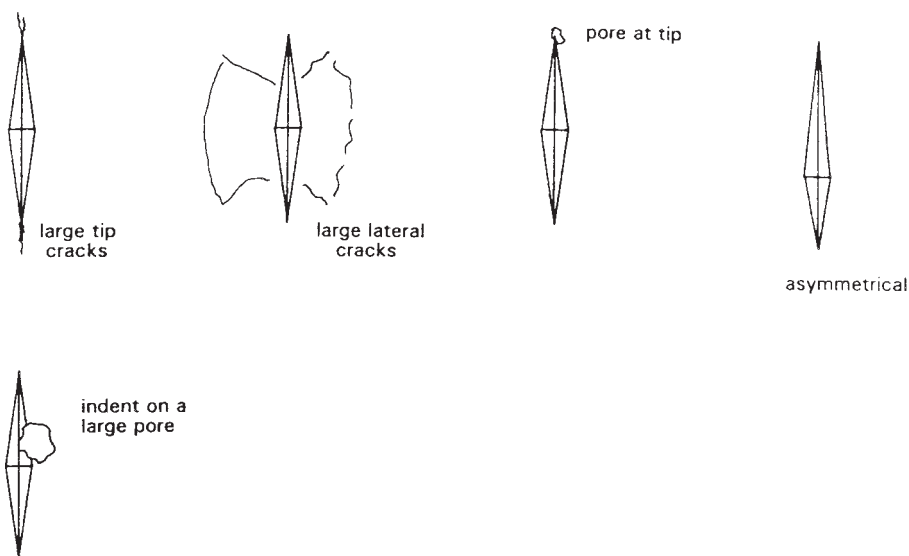

FIG. 3 Guidelines for the Acceptance of Indentations

$$= 0.014229 (P/d^2) \tag{1}$$

where:

- P = load, N,
- d = length of the long diagonal of the indentation, mm,
- A_p = projected area of the indentation, mm²,
- C_p = $1/2 (\cot A/2 \times \tan B/2)$, which ideally should be 0.07028,
- A = included longitudinal edge angle (see Fig. 1), which ideally should be 172° 30' 00", and
- B = included transverse edge angle (see Fig. 1), which ideally should be 130° 0' 00".

NOTE 12— This computation and set of units are in accordance with recommendations of Practice E 380.

NOTE 13—This test method does **not** apply a correction factor to d for the optical resolution limit for the objective lens.

12.3 The Knoop hardness number may be computed as follows:

$$HK = (P/d^2 C_p) = 14.229 P/d^2 \tag{2}$$

where:

- C_p = is the same as in 12.2, and:
- P = load, kgf, and
- d = length of the long diagonal of the indentation, mm.

NOTE 14—This computation is consistent with Test Method E 384.

Alternately, the Knoop hardness number may also be computed as follows:

$$HK = 0.102 (P/d^2 C_p) = (0.102)(14.229) P/d^2 \tag{3}$$

where:

- C_p = is the same as in 12.2, and:
- P = load, N, and
- d = length of the long diagonal of the indentation, mm.

NOTE 15—This computation is consistent with ISO 9385 and ENV 843-4.

NOTE 16— Eq 2 and Eq 3 compute the Knoop hardness number, which is dimensionless; for example, $HK = 1500$. HK formerly had been assigned units of kgf/mm². Eq 2 and Eq 3 produce the same Knoop hardness number.

NOTE 17—The factor 0.102 in Eq 3 becomes necessary through the

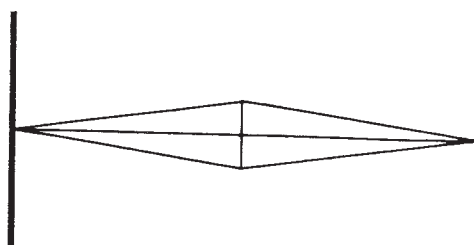

Crosshair

(a) **INCORRECT.** Crosshair completely covers the tip.

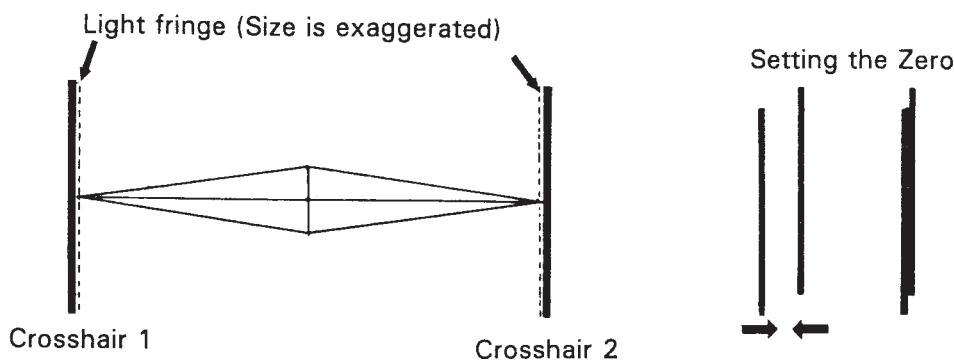

(b) **CORRECT.** Double crosshair measurement system, whereby the indentation is intended to be measured between two crosshairs or measuring lines. Indentation tips should be on the inside edge (in the fringe) of each crosshair. The measuring system is zeroed by bringing the inside measuring line inside edges together as shown on the right.

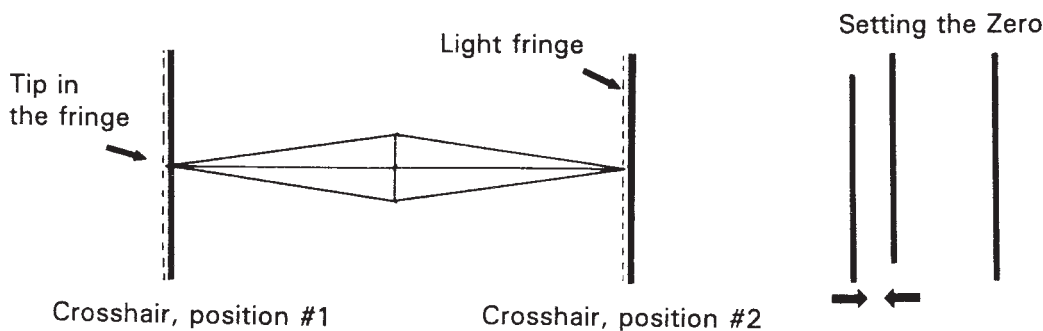

(c) **CORRECT.** Single crosshair and some double crosshair measurement systems. The indentation tip is on the same side of the crosshair line(s). The measuring system is zeroed with the tip on the same side of one line for a single crosshair system, or with both lines superimposed in a double crosshair system as shown on the right.

FIG. 4 Crosshair Measurement Systems

introduction of the SI unit newton for the test force instead of kilogram-force to avoid changing the value of the Knoop hardness number from its traditional units.

12.4 The mean hardness, \overline{HK} , is:

$$\overline{HK} = \frac{\sum HK_n}{n} \quad (4)$$

where:

HK_n = HK obtained from n th indentation, and

n = number of indentations.

12.5 The standard deviation, S , is:

$$S = \sqrt{\frac{\sum (\overline{HK} - HK_n)^2}{n - 1}} \quad (5)$$

12.6 The hardness HK symbol shall be supplemented by a number indicating the test force used, expressed in newtons multiplied by 0.102 (and therefore equal to the test force expressed in kilograms-force), and optionally a number indicating the duration of test force applications in seconds. So, for example, $HK2/15$ means the Knoop hardness for an applied test force of 19.61 N (2 kgf) applied for 15 s at full load.

13. Report

13.1 The report shall include the following information:

13.1.1 Mean HK ,

13.1.2 Test load,

13.1.3 Duration of test load,

13.1.4 Standard deviation,

13.1.5 Test temperature and humidity,

13.1.6 Number of satisfactory indentations measured, as well as the total number of indentations made,

13.1.7 Surface conditions and surface preparation,

13.1.8 Thermal history of the sample,

13.1.9 The extent of cracking (if any) observed, and

13.1.10 Deviations from the procedures in this test method, if any.

14. Precision and Bias

14.1 The precision and bias of microhardness measurements depend on strict adherence to the stated test procedure and are influenced by instrumental and material factors and indentation measurement errors.

14.2 The consistency of agreement for repeated tests on the same material is dependent on the homogeneity of the material, repeatability of the hardness tester, and consistent, careful measurements of the indents by a competent operator.

14.3 Instrumental factors that can affect test results include accuracy of loading, inertia effects, speed of loading, vibrations, the angle of indentation, lateral movement of the indenter or sample, and indentation and indenter shape deviations. Results are particularly sensitive to vibration or impact, which will produce larger indents and lower apparent hardness results.

14.4 The permitted deviation ($\pm 1\%$) in the indenter constant, C_p , can contribute up to $\pm 1\%$ variations in computed hardness if the constant for the idealized shape is used.

14.5 The largest source of error or uncertainty in hardness usually arises from the error and uncertainty in the measurement of the diagonal length.

14.5.1 The harder the material is, the smaller the indent size. Therefore, hardness uncertainties are usually greater for harder materials.

14.5.2 Diagonal length measurement errors include inaccurate calibration of the measuring device, inadequate resolving power of the objective, insufficient magnification, operator bias in sizing the indents, poor image quality, and nonuniform illumination. These can contribute to both bias and precision errors.

14.5.3 Several of the errors that contribute to diagonal length measurement uncertainty have the same magnitude irrespective of whether a 9.81 or 19.61 N force is used. Therefore, the higher indentation load is preferred since the indentation size will be larger and the percent error less.

14.5.4 *Uncertainty Due to Optical Resolution Limits:*

14.5.4.1 The resolution limit of optical microscopes contributes to both precision and bias uncertainties. This test method permits a range of objective lenses which can cause some variation in apparent diagonal length. The numerical aperture (NA) of the objective lens determines the maximum useful magnification and resolving power of the microscope. The higher the NA of the lens, the longer the indentation will appear. This resolution limitation leads to a bias error since the microscope is not able to resolve the exact tip and leads to underestimates of the true length. The hardness is thus overestimated.

14.5.4.2 This test method permits objective lenses with NAs from 0.65 to 0.90, which correspond to magnifications of 40 to 100 \times . The theoretical shortening in the diagonal (due to the optical resolution limit) has been estimated to be $7\lambda/2NA$, where λ is the wavelength of the light used (**3, 5, 9, 10**). Thus, the use of different lenses with different NA values will lead to different apparent indentation lengths. The maximum theoretical differential in the measured length for lenses with the NAs allowed by this test method is 0.8 μm . Experimental evidence suggests that the $7\lambda/2NA$ correction is too large (**3, 10–13**), and that 0.5 μm is a better estimate of the differential (**3, 10**). Thus, for 145 μm long indentations created by a 19.61 N force, the latitude in lens selection permitted in this test method can lead to a maximum hardness variability of 0.7%. A 100 μm long indentation created by a 9.81 N force will have a maximum 1.0% variability in this manner.

14.5.4.3 An estimate of the bias error due to the optical resolution limitation was made by comparing optical measurements to calibrated scanning electron microscope (SEM) measurements of the same indentations. (The SEM can resolve the tip location with much higher magnification and with no visible light diffraction phenomenon.) A single 19.61 N Knoop indentation in a silicon nitride standard reference material was measured by four observers with two optical microscopes with 40 \times (0.65 NA) objective lenses (**11–13**). Depending upon the observer and the microscope, the diagonal length measurements were between 0.4 to 2.1 μm shorter than the calibrated

TABLE 1 Precision of Diagonal Length Measurements Estimated from an Interlaboratory Round Robin Project (12,13)

Load, P (N)	Number of Laboratories	Average Diagonal Length, d (μm)	Within-Laboratory Repeatability		Between-Laboratory Reproducibility	
			Expanded Uncertainty ^A (μm)	Coefficient of Variation, %	Expanded Uncertainty ^A (μm)	Coefficient of Variation, %
19.61 ^B	11	141.5	2.7	0.7	8.5	2.2
19.61 ^C	5	142.4	3.1	0.8	4.1	1.0
9.81 ^C	10	98.3	2.0	0.7	7.1	2.6

^A Coverage factor of 2.8, corresponding to a 95 % confidence interval.

^B Indentations made by organizing laboratory.

^C Indentations made by participating laboratories.

SEM measurements (average: 146.8 μm, standard deviation: 0.2 μm). These correspond to bias errors of 0.5 to 2.9 % in hardness.

14.6 Interlaboratory Round Robin:

14.6.1 A round robin was conducted to evaluate the suitability of fully dense silicon nitride specimens as standard hardness test blocks (12,13). The results of this eleven-laboratory round robin can be used to evaluate the precision of Knoop hardness measurements for an advanced ceramic that does not pose difficult measuring problems. Within-laboratory repeatability and between-laboratory reproducibility were evaluated in accordance with Practices E 177 and E 691. The results are listed in Table 1, which shows the repeatability and reproducibility in measured diagonal lengths. (The hardness repeatability interval when expressed as a percentage is double the diagonal length repeatability interval.) Participants read

five indents made at 19.61 N at the organizing laboratory, and also made and measured five each of their own indents at 9.81 and 19.61 N. In general, within-laboratory repeatabilities of 0.7 to 0.8 % were obtained with both the 9.81 and 19.61 N indentation loads. Between-laboratory reproducibilities were 1.0 to 2.2 % for the 19.61 N indentations. The lower estimate was obtained from the five laboratories that were able to make 19.61 N indentations and the higher estimate was obtained from all eleven laboratories which read indentations made by the organizing laboratory. The between-laboratory reproducibility was 2.6 % for the 9.81 N indentations made by all laboratories.

15. Keywords

15.1 advanced ceramics; indentation; Knoop hardness; microscope

REFERENCES

- (1) Knoop, F., Peters, C. G., and Emerson, W. B., "A Sensitive Pyramidal-Diamond Tool for Indentation Measurements," *Journal of Research of the National Bureau of Standards*, Vol 23, 1939, pp. 39–61.
- (2) Thibault, N. W., and Nyquist, H. L., "The Measured Knoop Hardness of Hard Substances and Factors Affecting Its Determination," *Transactions of the American Society of Metals*, Vol 38, 1947, pp. 271–300.
- (3) Tarasov, L. P., and Thibault, N. W., "Determination of Knoop Hardness Numbers Independent of Load," *idem*, pp. 331–351.
- (4) Small, L., *Hardness Theory and Practice (Part I: Practice)*, Service Diamond Tool Co., Ann Arbor, MI, 1960, pp. 241–243.
- (5) Mott, B. W., *Micro-Indentation Hardness Testing*, Butterworth's Scientific Publications, London, 1956.
- (6) Blau, P. J., "Methods and Applications of Microindentation Hardness Testing," *Applied Metallography*, Vander Voort, G. F., ed., Van Nostrand-Reinhold, 1986, pp. 123–138.
- (7) Naylor, M. G. S., and Page, T. F., "Microhardness, Friction and Wear of SiC and Si₃N₄ Materials as a Function of Load, Temperature and Environment," Third Annual Technical Report, Cambridge University, England, October 1981.
- (8) Clinton, D. J., and Morrell, R., "Hardness Testing of Ceramic Materials," *Material Chemistry and Physics*, Vol 17, 1987, pp. 461–473.
- (9) Brown, A. R. G., and Ineson, E., "Experimental Survey of Low-Load Hardness Testing Machines," *Journal of Iron and Steel Institute*, Vol 169, 1951, pp. 376–388.
- (10) Gahm, J., "Neuere Erkenntnisse zur Mikro-Härte," (New Results on Microhardness), Verein Deutscher Ingenieure-Berichte (Society of German Engineers, Reports), Nr 160, 1972, pp. 25–41.
- (11) Gettings, R. J., Quinn, G. D., Ruff, A. W., and Ives, L. K., "New Hardness Standard Reference Materials (SRMs) for Advanced Ceramics," *Ceramic Engineering and Science Proceedings*, Vol 15, No. 5, 1994, pp. 817–826.
- (12) Gettings, R. J., Quinn, G. D., Ruff, A. W., and Ives, L. K., "Development of Ceramic Hardness Reference Materials," pp. 617–624 in *New Horizons for Materials*, Proceedings of the 8th World Congress on Ceramics, Florence, Italy, July, 1994, Vincenzini, P., ed., Techna, Faenza, 1995.
- (13) Gettings, R. J., Quinn, G. D., Ruff, A. W., and Ives, L. K., "Hardness Standard Reference Materials (SRM) for Advanced Ceramics," *Verein Deutscher Ingenieure Reports*, 1194, 1995, pp. 255–264.

**NOTICE: This standard has either been superseded and replaced by a new version or discontinued.
Contact ASTM International (www.astm.org) for the latest information.**



ASTM International takes no position respecting the validity of any patent rights asserted in connection with any item mentioned in this standard. Users of this standard are expressly advised that determination of the validity of any such patent rights, and the risk of infringement of such rights, are entirely their own responsibility.

This standard is subject to revision at any time by the responsible technical committee and must be reviewed every five years and if not revised, either reapproved or withdrawn. Your comments are invited either for revision of this standard or for additional standards and should be addressed to ASTM International Headquarters. Your comments will receive careful consideration at a meeting of the responsible technical committee, which you may attend. If you feel that your comments have not received a fair hearing you should make your views known to the ASTM Committee on Standards, at the address shown below.

This standard is copyrighted by ASTM International, 100 Barr Harbor Drive, PO Box C700, West Conshohocken, PA 19428-2959, United States. Individual reprints (single or multiple copies) of this standard may be obtained by contacting ASTM at the above address or at 610-832-9585 (phone), 610-832-9555 (fax), or service@astm.org (e-mail); or through the ASTM website (www.astm.org).