



Standard Test Method for Reheat Change of Insulating Firebrick¹

This standard is issued under the fixed designation C 210; the number immediately following the designation indicates the year of original adoption or, in the case of revision, the year of last revision. A number in parentheses indicates the year of last reapproval. A superscript epsilon (ϵ) indicates an editorial change since the last revision or reapproval.

This standard has been approved for use by agencies of the Department of Defense.

1. Scope

1.1 This test method covers the determination of the permanent linear (and volume) change of insulating firebrick upon reheating under prescribed conditions.

1.2 The values stated in inch-pound units are to be regarded as the standard. The values given in parentheses are for information only.

1.3 *This standard does not purport to address all of the safety concerns, if any, associated with its use. It is the responsibility of the user of this standard to establish appropriate safety and health practices and determine the applicability of regulatory limitations prior to use.*

2. Referenced Documents

2.1 ASTM Standards:

C 24 Test Method for Pyrometric Cone Equivalent (PCE) of Fireclay and High Alumina Refractory Materials²

C 155 Classification of Insulating Firebrick²

E 230 Standard Temperature Electromotive Force (EMF) Tables for Standardized Thermocouple³

E 1256 Test Methods for Radiation Thermometer (Single Waveband Type)³

3. Significance and Use

3.1 Insulating firebrick (IFB) are classified by their bulk density and reheat change (see Classification C 155). This test method defines thermal stability by measurement of IFB's reheat change following 24 h at a test temperature.

3.2 Since this test exposes the entire sample to an isothermal temperature condition, the user should be aware that most applications for IFB involve a thermal gradient which may cause the IFB's dimensions to change differentially.

4. Apparatus

4.1 The test kiln shall be capable of maintaining the required temperature with a variation of not more than one half

a standard pyrometric cone over the hearth area during the prescribed heating schedule. If a gas- or oil-fired kiln is used, it shall be of the downdraft type and of such a design as not to permit the flame from the burner to impinge upon the test specimens. The kiln atmosphere during the test shall be kept as oxidizing as is practicable.

5. Procedure

5.1 Test Specimens and Measurements:

5.1.1 The test specimens shall consist of three brick (Note 1) measuring 9 by 4½ by 2½ or 3 in. (228 by 114 by 64 or 76 mm) or three pieces of these dimensions cut out of larger shapes.

NOTE 1—Three supporting brick from the same lot as the test specimens are required also, so that the test sample is comprised of six brick.

5.1.2 Each specimen shall be labeled with ceramic paint, and before and after heating they shall be carefully measured for length (Note 2), width, and thickness. Three measurements (Note 3) to the nearest 0.02 in. (0.5 mm) shall be taken for each dimension and the average of these shall be used. Each dimension shall be measured in three places along the longitudinal center line on opposite faces, one measurement at the center of the line and one ½ in. (13 mm) in from each edge. Fig. 1 shows the location at which these measurements are to be made.

NOTE 2—For classifying insulating firebrick according to Classification C 155, obtain the reheat change from the 9-in. (228-mm) dimension measurements only.

NOTE 3—Because of the large pore size of some insulating firebrick, it is difficult to measure by means of calipers directly on the brick surfaces. Accuracy may be obtained by holding two small pieces of flat polished steel plate of known thickness against the faces between which the dimension is to be obtained, and caliper on the outside steel surfaces rather than directly against the brick surfaces. It is permissible to use a measuring device to obtain the dimensions of the brick, provided the measurements are not affected by large pores in the surface.

5.2 Placing Test Specimens in Kiln:

5.2.1 Place the test specimens in the kiln so that each will rest on a 9 by 2½ or 3-in. (228 by 64 or 76-mm) face. Place each specimen upon the 9 by 2½ or 3-in. face of a supporting brick that shall be from the same lot as the test specimen. Place between the test specimen and the supporting member a layer of suitable refractory material, that is nonreactive under the test

¹ This test method is under the jurisdiction of ASTM Committee C08 on Refractories and is the direct responsibility of Subcommittee C08.03 on Physical Tests.

Current edition approved May 15, 1995. Published July 1995. Originally published as C 210 – 46. Last previous edition C 210 – 85 (1990). Originally part of C 93.

² *Annual Book of ASTM Standards*, Vol 15.01.

³ *Annual Book of ASTM Standards*, Vol 14.03.

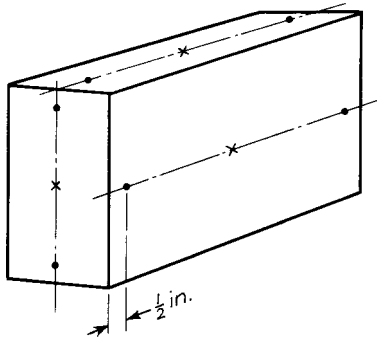

NOTE 1—The dots on the center line of each face are 1/2 in. (13 mm) in from each edge, and the cross on the axis is in the center. These positions indicate the points at which three measurements for each dimensions are to be made.

FIG. 1 Test Brick Showing Measurement Locations

conditions and passes an ASTM No. 16 (1.18-mm) sieve

(equivalent to a 14-mesh Tyler Standard Series) and retained on an ASTM No. 40 (425- μ m) sieve (equivalent to a 35-mesh Tyler Standard Series). Place each specimen no closer than 1 1/2 in. (38 mm) from either the other test specimens or the furnace wall and parts.

6. Temperature Measurement

6.1 Measure the temperature within the kiln by means of an appropriate calibrated thermocouple. Refer to Table 1 and Table 2 of Standard E 230 for the tolerances and upper temperature limits for use of various thermocouples. At higher temperatures, the thermocouple may be withdrawn and a calibrated optical or radiation pyrometer (refer to Test Method E 1256) can be used. Place the hot junction of the thermocouple or sight the pyrometer so as to register the temperature of the test specimens. Make temperature readings at intervals not greater than 15 min. Check the kiln periodically by thermocouples, pyrometers, or pyrometric cones (refer to Test Method C 24) to ensure that temperature over the hearth does not differ by more than 25°F (14°C) or one-half cone.

TABLE 1 Heating Schedule for Reheat Change of Various Groups of Insulating Firebrick

Elapsed Time from Start of Heating, h	Allowable Deviation from Schedule, \pm °F (°C)	Temperature of Test Specimen, °F (°C) (The highest temperature in each column shall be maintained for 24 h)							
		Group 16 1550°F (845°C) Test	Group 20 1950°F (1065°C) Test	Group 23 2250°F (1230°C) Test	Group 26 2550°F (1400°C) Test	Group 28 2750°F (1510°C) Test	Group 30 2950°F (1620°C) Test	Group 32 3150°F (1730°C) Test	Group 33 3250°F (1790°C) Test
1	50 (28)	1050 (565)	1310 (710)	1470 (800)	1750 (955)	1750 (955)	1750 (955)	1750 (955)	1750 (955)
1 1/2	35 (19.5)	1260 (680)	1580 (860)	1820 (995)	2130 (1165)	2130 (1165)	2130 (1165)	2200 (1205)	2200 (1205)
2	20 (11)	1420 (770)	1790 (975)	2050 (1120)	2370 (1300)	2370 (1300)	2370 (1300)	2430 (1330)	2500 (1370)
2 1/2	15 (8.5)	1520 (825)	1910 (1045)	2200 (1205)	2510 (1375)	2560 (1405)	2560 (1405)	2640 (1450)	2700 (1480)
3	15 (8.5)	1550 (845)	1950 (1065)	2250 (1230)	2550 (1400)	2680 (1470)	2680 (1470)	2800 (1540)	2840 (1560)
				
3 1/2	15 (8.5)	2730 (1500)	2810 (1545)	2890 (1590)	2960 (1625)
4	15 (8.5)	2750 (1510)	2880 (1580)	2960 (1625)	3040 (1670)
					
4 1/2	15 (8.5)	2930 (1610)	3020 (1660)	3100 (1705)
5	15 (8.5)	2950 (1620)	3060 (1680)	3150 (1730)
						
5 1/2	15 (8.5)	3100 (1705)	3175 (1745)
6	15 (8.5)	3125 (1720)	3200 (1760)
6 1/2	10 (5.5)	3150 (1730)	3225 (1775)
7	10 (5.5)	3240 (1732)
7 1/2	10 (5.5)	3250 (1790)

TABLE 2 Precision Statistics

Attribute	Average	Precision Data				Relative Precision			
	Linear %	Standard Deviation Within Laboratories, % Sr	Standard Deviation Between Laboratories, % SR	Repeatability Interval, % r	Reproducibility Interval, % R	Within Laboratories, % Vr	Between Laboratories, % VR	Relative Repeatability, % r	Relative Reproducibility, % R
Reheat Change K 20	0.01	0.03	0.03	0.08	0.08	387.30	387.30	1084.44	1084.44
Reheat Change K 26 LI	-0.26	0.09	0.11	0.24	0.31	-33.48	-42.96	-93.74	-120.28
Reheat Change K 3000	-0.24	0.08	0.18	0.23	0.50	-33.66	-73.41	-94.23	-205.54

7. Test Temperature Schedules and Duration of Test

7.1 The temperature to be used for the test shall depend on the classification into which the insulating firebrick falls (see Classification C 155).

7.2 The heating schedules for the various classes of insulating firebrick are given in Table 1. Maintain the maximum temperature for a period of 24 h, and leave the specimens in the kiln until the temperature has fallen to about 800°F (430°C). Blisters may develop on the surface of the test brick, in which case remove them by rubbing their surfaces very lightly with a fine abrasive block before remeasuring in accordance with 5.1.2.

8. Calculation and Report

8.1 *Reheat Change*—Calculate the reheat change in percent from the average measurement for the dimension obtained before and after reheating.

8.2 *Reheat Volume Change*—When the reheat volume change is requested, calculate it from the average measurement for the three dimensions obtained before and after reheating, as follows:

$$V = [(V_o - V_f)/V_o] \times 100 \quad (1)$$

where:

V = volume change, percent,
 V_o = original volume, and
 V_f = final volume.

8.3 *Report*—When the test is conducted for evaluating insulating firebrick in accordance with Classification C 155, the average linear change for the 9-in. (228-mm) dimension *only* shall be reported; otherwise, or when specified, the average of the reheat change for the length, width, and thickness shall be reported and, if requested, the average reheat volume change.

9. Precision and Bias

9.1 *Interlaboratory Test Program*—An interlaboratory test program between six laboratories was conducted. Each laboratory received 3 samples each of three insulating firebricks, K-20, K-26 LI, and K-3000. The bricks were provided by Thermal Ceramics. The laboratories participating were C.E. Minerals, Orton RRC, North American Refractories, National Refractories, Thermal Ceramics, and Premier Refractories.

9.2 Precision:

9.2.1 *Repeatability*—The maximum permissible difference due to test error between two test results obtained by one operator on the same material is given by the repeatability interval and the relative repeatability interval (coefficient of variation). The 95 % repeatability intervals are given in Table 2. Two test results that do not differ by more than the repeatability interval will be considered the same and, conversely, two test results that do differ by more than the repeatability interval will be considered different.

9.2.2 *Reproducibility*—The maximum permissible difference due to test error between two test results obtained by two operators in different laboratories on the same type of material using the same type of test equipment is given by the reproducibility interval and relative reproducibility interval (coefficient of variation). The 95 % reproducibility intervals are given in Table 2. Two test results that do not differ by more than the reproducibility interval will be considered the same and, conversely, two test results that do differ by more than the reproducibility interval will be considered different.

9.3 *Bias*—No justifiable bias statement is possible since the true values of the properties of the reference material are not defined.

10. Keywords

10.1 insulating firebrick; permanent linear change; refractories; reheat change

The American Society for Testing and Materials takes no position respecting the validity of any patent rights asserted in connection with any item mentioned in this standard. Users of this standard are expressly advised that determination of the validity of any such patent rights, and the risk of infringement of such rights, are entirely their own responsibility.

This standard is subject to revision at any time by the responsible technical committee and must be reviewed every five years and if not revised, either reapproved or withdrawn. Your comments are invited either for revision of this standard or for additional standards and should be addressed to ASTM Headquarters. Your comments will receive careful consideration at a meeting of the responsible technical committee, which you may attend. If you feel that your comments have not received a fair hearing you should make your views known to the ASTM Committee on Standards, at the address shown below.

This standard is copyrighted by ASTM, 100 Barr Harbor Drive, PO Box C700, West Conshohocken, PA 19428-2959, United States. Individual reprints (single or multiple copies) of this standard may be obtained by contacting ASTM at the above address or at 610-832-9585 (phone), 610-832-9555 (fax), or service@astm.org (e-mail); or through the ASTM website (www.astm.org).